

Trojan Horse attacks on Quantum Key Distribution systems

N. Gisin¹, S. Fasel¹, B. Kraus¹, H. Zbinden¹, G. Ribordy²

¹*Group of Applied Physics, University of Geneva, 1211 Geneva 4, Switzerland*

²*id Quantique SA, 3 Ch. de la Marbrerie, 1227 Carouge/Geneva, Switzerland*

(Dated: November 26, 2024)

General Trojan horse attacks on quantum key distribution systems are analyzed. We illustrate the power of such attacks with today's technology and conclude that all system must implement active counter-measures. In particular all systems must include an auxiliary detector that monitors any incoming light. We show that such counter-measures can be efficient, provided enough additional privacy amplification is applied to the data. We present a practical way to reduce the maximal information gain that an adversary can gain using Trojan horse attacks. This does reduce the security analysis of the 2-way *Plug-&-Play* system to those of the standard 1-way systems.

PACS numbers:

I. INTRODUCTION

The prominent application of quantum information science is Quantum Key Distribution (QKD), which, together with quantum random number generators, is the most advanced realization of quantum devices operating at the single quanta level[1]. QKD offers the potential to develop for the first time in human history provenly secure communication channels between distant partners. The latter should be connected by a so-called quantum communication channel, i.e. a channel able to transmit individual quantum systems well enough isolated from the outside world such that the receiver gets them almost unperturbed. In practice these quantum communication channels can be realized, among others, with standard telecom optical fibers or with free space in line-of-sight optical channels. In both cases the transmitted individual systems are photons. Quantum physics, in particular the no-cloning theorem (a form of the famous Heisenberg uncertainty relations, suitable for the analysis of QKD) guarantees that

1. the presence of any eavesdropper on the quantum communication channel can be detected by the legitimate users, and
2. the legitimate users can upper bound the information that any eavesdropper could gain by eavesdropping the quantum communication channel. Consequently, the legitimate users can lower bound the amount of privacy amplification they need to apply on their data in order to reduce the eavesdropper's information to an exponentially small value.

Accordingly, quantum physics guarantees potential[24] security against any possible attack on the quantum communication channel[2, 3, 4, 5, 6].

Today a lot is known about the most powerful attacks Eve could ever perform against the quantum channel, assuming Eve has absolutely no technological limits, i.e. she can do everything that quantum physics does not explicitly forbid. But, clearly, Eve's attacks are not limited

to the quantum communication channel. For instance, Eve could attack Alice or Bob's apparatuses, or she could exploit weaknesses in the actual implementation of abstract QKD.

Quantum physics does not help protecting Alice and Bob's apparatuses. Indeed, as soon as the information is encoded in a classical physics system, it is vulnerable to copying and broadcasting. Hence, Alice and Bob's electronics has to be protected by classical means. Interestingly, one may ask where the transition from quantum coding to classical coding happens. This is an old question, the famous quantum/classical foggy transition, but here in a modern setting: it determines what can be protected by quantum means and what has to be protected by classical means. But we shall not consider this question in this article. It is anyway obvious that Alice and Bob's apparatuses need classical protections.

Actual implementations of abstract QKD uses today's technology (and economical constrains). Hence they necessarily move somewhat away from the ideal scheme. It is thus of vital importance for QKD to analyze properly the consequences of these compromises. Indeed, some compromises might render the entire system totally insecure, while some other compromises can be proven to maintain absolute security, provided their analyzes are properly taken into account. Let us stress this important point: some well implemented compromises do not at all reduce the security of QKD[7, 8, 9, 10].

An example of a very common and convenient compromise is the use of weak laser pulses instead of the single-photon sources that are closer to abstract qubits. This was first shown to open new eavesdropping strategies[11, 12]. Next, it has been proven that secure QKD is nevertheless possible, provided the weak intensity of the pulses and the quantum communication channel loss are properly taken into account[7, 8, 9, 10]. Finally, recently, variations of the basic QKD protocols have been proposed that significantly lighten the conditions for secure QKD using weak laser pulses[13, 14, 15].

It is thus timely to study another unavoidable aspect of QKD: the quantum channel itself is a potentially open door for an eavesdropper into Alice and Bob's appara-

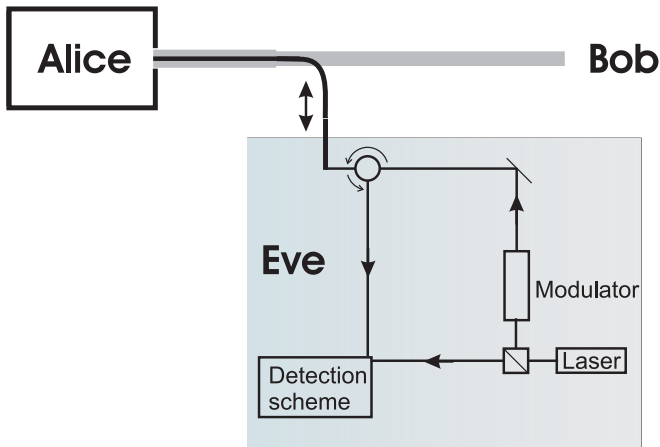

FIG. 1: Principle of a Trojan Horse attack. Eve occupied part of the quantum channel (i.e. the spatial, temporal and frequency modes) to probe Alice's apparatus. Eve uses an auxiliary source, modulates it and analyzes the backscattered signal with a detector. Note that her detection scheme can rely on specificities of her auxiliary source, for instance on its phase. Eve may have to remove part of the legitimate signal, compensating the introduced loss by an improved quantum channel.

tuses. Indeed, even if this door is properly designed, Eve could use it precisely at the same time as the legitimate users: Eve could send into Alice and/or Bob's apparatuses light pulses during the (short) times the quantum channel is open[25], see Fig. 1. In order to limit this possibility, the system should be designed in such a way that

1. only light at appropriate wavelength can enter (i.e. filters),
2. the "door" should be open only during short times, i.e. the encoding optical components should be active only during short times (i.e. activate phase modulators only when the qubits is there), and
3. the amount of reflected light that could be exploited by Eve is bounded by a known value.

The purpose of this article is to analyze such attacks, known as Trojan horse attacks. In particular we shall examine each of the above points in section III. But, first, it is useful to get a better understanding of the techniques that such an adversary could use, see section II. Next, in section IV we derive the photon number statistics of any light used in Trojan horse attacks and in V we compute the maximal information that Eve could gain using Trojan horse attacks, i.e. compute how much

additional privacy amplification is required in order to successfully combat such attacks. Finally, in section VI we present a simple way to reduce this information, hence to increase the secret bit rate.

II. REFLECTOMETRY

Every optical element backscatters some amount of any incoming light. This might be small in optical fibers (about -70dB/m) and angle-polished connectors (typically -40dB), medium for integrated optics components, like phase-modulators (≈ -20 dB) and large for mirrors (≥ -1 dB).

Consequently, every optical apparatus can be examined from the outside by shining into it well controlled light and analyzing the backscattered light. This technique, named reflectometry, is a standard tool for optical engineers.

For security analysis of QKD one assumes an Eve without any technological limit. But it is useful to have an idea how the technique works in principle and to illustrate it with today's technology.

There are essentially two approaches to reflectometry:

1. Send in short optical pulses and analyze the backscattered light intensity in function of time. From the known speed of light, the time can be translated into distances. This technique is called Optical Time Domain Reflectometry (OTDR), it is a very standard tool of optical telecom engineers[16, 17] (see figure 2).

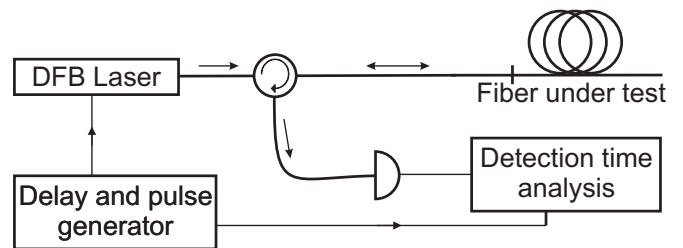

FIG. 2: Functional schematic of OTDR

2. Send in coherent cw light while scanning its optical frequency and analyze the spectrum of the backscattered light. Different reflections correspond to different emission times, hence to different optical frequencies. They do thus produce a beat signal. Usually one produces on purpose one relatively large reflection (inside the instrument) which acts as a local oscillator. The frequency of the backscattered signal can be translated into distance by a Fourier transformation. This technique is called Optical Frequency Domain Reflectometry (OFDR). It is not yet as standard as OTDRs, but, thanks to its heterodyne detection scheme, it holds the potential of a much larger sensitivity and dynamical range[18] (see figure 3).

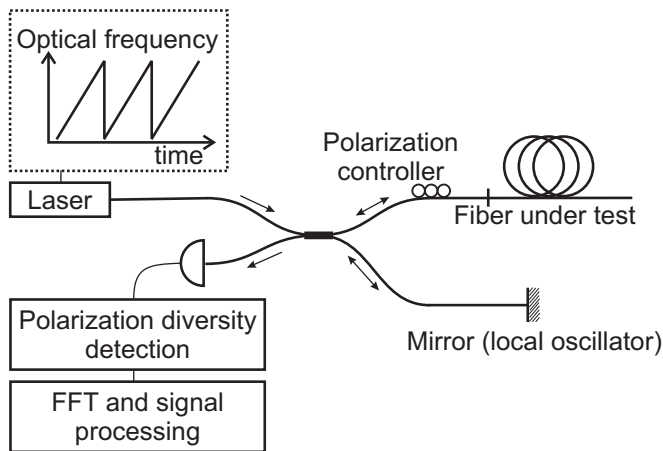

FIG. 3: Functional schematic of OFDR

The main drawback of today's OFDRs compared to OTDRs is their limited distance range, due to the finite coherence length of the cw laser. But, as Eve has no technological limits, we shall mainly illustrate the potential of Trojan horse attacks using this technique. Let us emphasize that this section is only an illustration, clearly the counter measure by Alice and Bob should take into account reflectometry techniques beyond today's technique.

Fig. 4 and 5 present the backscattered light from Alice and Bob's apparatuses, respectively, in the case of our Plug-&-Play quantum cryptography system[19, 20]. They illustrate that indeed quite a lot of information can be gained by probing the apparatuses from the outside. Let us emphasize that the same is true for all other fiber-based apparatus, like for instance optical amplifiers[21] and any other quantum cryptography system. The details are given in the figure captions. Note that for the purpose of this demonstration, we removed the about 10 km long delay line in Alice's apparatus, because our laser (contrary to that of Eve) has a coherence length limited to about 1 km).

Note that it isn't yet clear how Eve could probe the setting of the phase-modulator. However, Eve can indeed probe this setting by exploiting the change in birefringence in Titan-indiffused LiNbO₃ integrated waveguides, as illustrated in Fig. 6. For different kinds of phase modulators, or polarization modulators, it is highly likely that a similar technique applies. Figure 6 shows that it is easy to distinguish between two phase settings of Alice's phase modulator. To obtain Fig. 6 we had to keep the phase setting constant during about one second, that is, a much longer time than in the usual use of the crypto system. We also had to adjust the polarization of the probe light and to use a polarization dependant OFDR settings, to maximize the effect. Nevertheless, this result underlines that Trojan horse attacks have to be analyzed seriously.

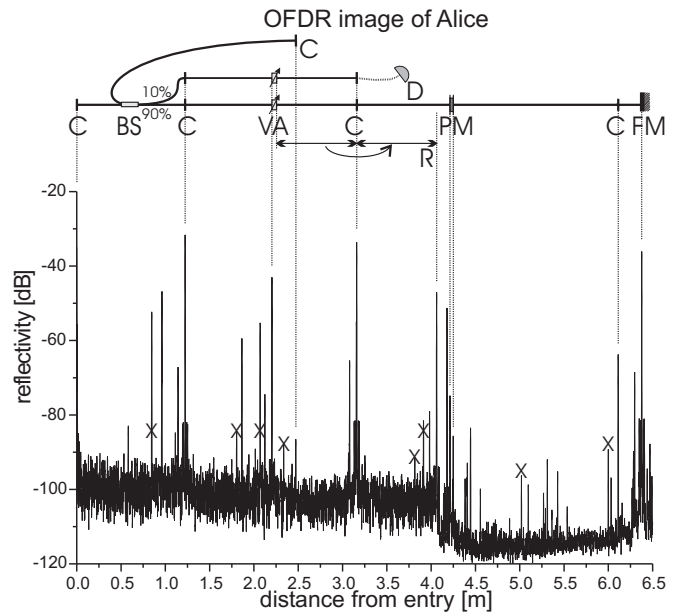

FIG. 4: Example of an OFDR trace of Alice's Plug-&-Play QKD system in which we removed the delay line and set the variable attenuator to its minimal value. A sketch of the optical circuit is displayed at the top with the corresponding reflections peaks below. The beam splitter (BS), connector (C), variable attenuator (VA), detector (D), phase modulator (PM) and Faraday mirror (FM) are all clearly visible. The peak marked R correspond to an example of multiple internal reflections. The peaks marked with a cross correspond to spurious reflections between the OFDR and Alice's components.

III. HARDWARE COUNTER MEASURES

The previous section demonstrated that Trojan horse attacks on badly designed system can be performed using today's techniques. Consequently, every proper implementation should take care that:

1. the "door" lets in only wavelengths close to the operating wavelength. Any other probe should be eliminated by properly designed filters, and
2. the "door" should be open only during a time as short as possible: the phase modulator, or polarization modulator, or whatever coding device is used, should be activated only during the short time when the legitimate signal is there.

But even these two measures can't completely prevent Trojan horse attacks. Indeed, Eve can multiplex her probe signal with the legitimate signal either in polarization (if time-bin qubits are used by Alice and Bob) or in wavelengths (Eve could reduce the loss of the Q channel, filter out a part of the legitimate signal and use this bandwidth for her Trojan horse attack, see fig. 1). Also, in practice, timing has a finite accuracy, hence Eve can add her probes immediately before or after the legitimate pulses.

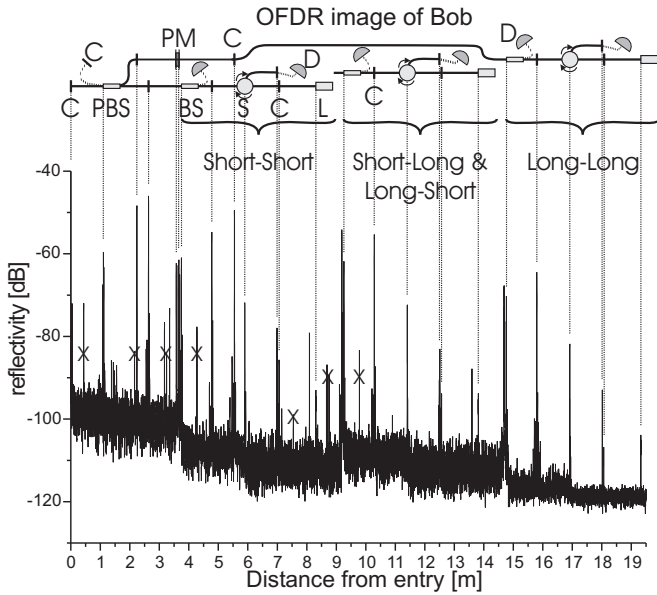

FIG. 5: Example of an OFDR trace of Bob's Plug-&-Play QKD system. Similar to Fig 4, but with the additional complication that each peak appears 3 times, because the incoming and reflected light both split in two, following the short and long path of the interferometer. For instance, one can notice that the long arm of the interferometer is about 11.5 meters longer than the short arm.

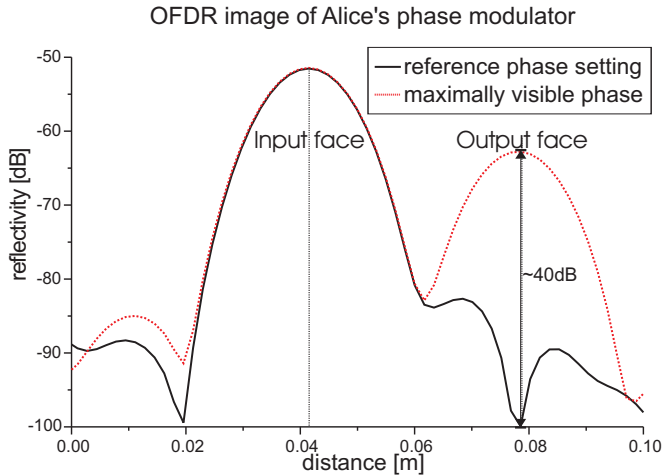

FIG. 6: OFDR traces of an integrated optics phase modulator. Two different phase settings give rise to clearly distinguishable back-scatterings on the output face of the modulator. The two phase settings and the polarization of the probe light are chosen especially to exhibit a very clear effect. The measurement time is of about one second.

Consequently, a first conclusion is that every sensitive apparatus (Alice for sure, Bob depending on the protocol) must have an **active control on the intensity of the incoming light**: they should use an auxiliary detector and monitor any incoming light. The software should be designed such as to stop QKD as soon as anomalous

intensities are detected (actually, for each qubit, there should be a test!).

A first naive idea to circumvent the need for an auxiliary detector is the use of attenuators and/or isolators. However, since Eve is not limited by technology, she could merely send in more intense light[26].

A second idea could be the use of an "optical fuse", i.e. a device that cuts the quantum channel if a too intense beam passes through it. This is a delicate technological problem. Indeed, there is no such fuse operating for ultra-short pulses. Hence, this does not seem like a practical idea, though one should keep it in mind.

In practice there is a natural fluctuation in the legitimate light and real detectors and electronics also contribute to the fluctuation of the monitoring signal. Hence, being conservative, one has to evaluate how much light can go to Eve without being detected and how much information she could extract from it. Then, appropriate privacy amplification should be applied to Alice and Bob's data. The amount of necessary privacy amplification for any bounded probe by Eve is computed in the next section.

IV. STATISTICS OF EVE'S PROBE LIGHT

One may question which state of light Eve should use in order to maximize her information gain. However, it is a well known fact that losses tend to turn any state into a state whose photon number statistics is Poissonian. This is illustrated on Fig. 7 for the cases of 10 and 20 dB losses (i.e. transmissions of 0.1 and 0.01, respectively) and mean photon number, after attenuation, $\mu = 0.5$. Since all quantum cryptography systems (should) have attenuators and/or isolators attenuating any light used in a Trojan Horse attack even more severely, it is sufficient to consider light with Poissonian statistics.

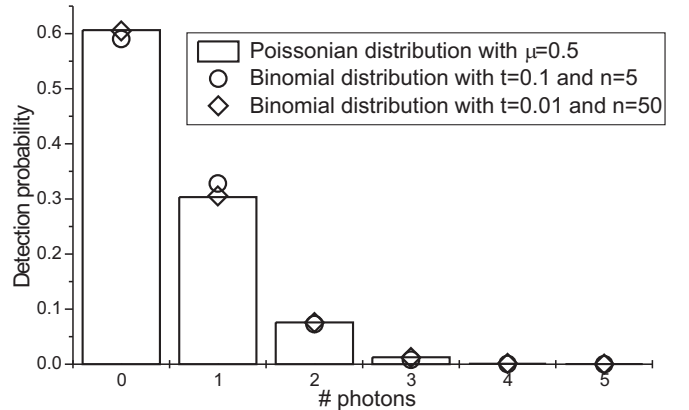

FIG. 7: Comparison of photon-number distribution for Poissonian and binomial distribution of the same average value. μ : average number of photons; t : transmission factor for Eve's probe light, corresponding e.g. the attenuation at Alice's input; n : number of photon in the Eve's Fock-state probe light.

Note that this does also imply that Eve can't significantly affect the statistics of the photon number emitted by Alice in the Plug-&-Play configuration, even if she replaced the intense coherent pulse send by Bob by a squeezed state. We elaborate on this in section VII.

V. EVE'S POTENTIAL INFORMATION GAIN

In this section we use well-known formulas to quantify the information that Eve can extract from a weak coherent state when she knows the "basis". Note, first that because of the huge attenuation that any trojan horse probe light undergoes, it will always return to Eve in a state extremely close to Poissonian, as described in the previous section IV. At best, from Eve's point of view, it bears some coherence, that is, it is a coherent state.

Note furthermore that because of the vacuum component of the weak coherent state, the two states corresponding to the "basis" are not orthogonal. Explicitly, Eve has to distinguish between the following two states $|\alpha\rangle \otimes |0\rangle$ and $|0\rangle \otimes |\alpha\rangle$. The measurement that maximizes her information gain is known[22] and provides her with:

$$I_{Eve}^{Trojan}(|\alpha|^2) = 1 - H(p) \quad (1)$$

where

$$p = \frac{1}{2}(1 + \sqrt{1 - |\langle \alpha, 0 | 0, \alpha \rangle|^2}) \quad (2)$$

$$= \frac{1}{2}(1 + \sqrt{1 - \exp(-2|\alpha|^2)}) \quad (3)$$

$$\approx \frac{1 + \sqrt{2}|\alpha|}{2}, \quad (4)$$

and H denotes the binary entropy. Hence:

$$I_{Eve}^{Trojan}(|\alpha|^2) \approx \frac{1}{\ln(2)}|\alpha|^2 + O(|\alpha|^4) \quad (5)$$

where $\frac{1}{\ln(2)} \approx 1.443$. This information gain is presented graphically in Fig 8.

Surprisingly, this is larger than the probability that the weak pulse is non-empty:

$$Prob(non\ empty) = 1 - \exp(-|\alpha|^2) \approx |\alpha|^2 \quad (6)$$

The reason for this difference is that eq. (2) assumes that Eve does really hold a coherent state, i.e. that she holds a phase reference relative to which α is defined. This observation leads to a possible way to reduce Eve's maximal information gain, as discussed in the next section.

VI. WAY TO REDUCE EVE'S INFORMATION

Figure 1 illustrates how Eve should probe Alice and/or Bob's apparatus in order to gain as much information about their internal settings. Since Eve's gain can be

significant, Alice and Bob have to sacrifice a significant fraction of their raw key before obtaining a secret key. It is thus of great interest to them to find ways to limit Eve's information. One possibility that we present in this section, consists in Alice or Bob randomizing the phase of $|\alpha\rangle$ relative to Eve's reference. In this way, Eve does no longer hold $|\alpha, 0\rangle$ or $|0, \alpha\rangle$, depending on the internal setting of the apparatus, but holds the mixed state ρ_0 or ρ_1 , respectively, where:

$$\rho_0 = \int_0^{2\pi} \frac{d\theta}{2\pi} |e^{i\theta}\alpha, 0\rangle \langle e^{i\theta}\alpha, 0| \quad (7)$$

$$= \sum_{n \geq 0} P(n|\alpha|^2) \cdot |n, 0\rangle \langle n, 0| \quad (8)$$

$$\rho_1 = \int_0^{2\pi} \frac{d\theta}{2\pi} |0, e^{i\theta}\alpha\rangle \langle 0, e^{i\theta}\alpha| \quad (9)$$

$$= \sum_{n \geq 0} P(n|\alpha|^2) \cdot |0, n\rangle \langle 0, n| \quad (10)$$

where $P(n|\alpha|^2) = \frac{|\alpha|^{2n}}{n!} e^{-|\alpha|^2}$ denotes the Poisson probability distribution. Eve optimal measurement distinguishing ρ_0 and ρ_1 is also known. Eve first measures the photon number. If she finds no photon, she clearly gains no information. However, whenever she finds one or more photon, then she gains full information. Hence her optimal information gain equals the probability that the weak coherent state $|\alpha\rangle$ is not empty:

$$I_{Eve}^{reduced}(|\alpha|^2) = 1 - P(0|\alpha|^2) = 1 - \exp(-|\alpha|^2) \approx |\alpha|^2 \quad (11)$$

Interestingly, $I_{Eve}^{reduced}(|\alpha|^2) < I_{Eve}^{Trojan}(|\alpha|^2)$; it is thus of practical value for Alice and Bob to add random phases to any light that might get back-scattered. Let us emphasize that, clearly, these random phases act as irrelevant global phases on the qubits, hence do not affect the proper operation of QKD, but these random phases are relative to any possible reference that Eve might hold, hence do reduce by the significantly factor $\frac{1}{\ln(2)} \approx 1.44$ the maximal information that Eve could gain using this back-scattered light[23].

VII. REDUCTION OF SECURITY ANALYSIS OF 2-WAY SYSTEMS TO 1-WAY SYSTEMS

In a 2-way quantum cryptography system, like the so-called Plug-&-Play configuration [19, 20], Eve may hold the strong pulse that enters Alice's apparatus. Let's write $\psi = \sum_{n \leq 0} c_n |n\rangle$ its state, where $|n\rangle$ denotes a state of n photons in some appropriate mode. Note that we assume a pure state, i.e. that the phase reference, relative to which the complex amplitudes c_n are defined, is classical. It is straightforward to general the analysis to the case where Eve's reference is a quantum state, i.e. Eve sends into Alice's apparatus a state entangled with an

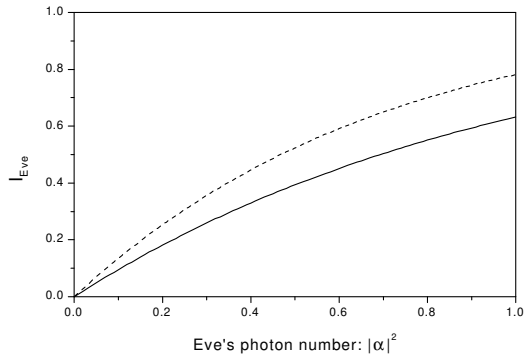

FIG. 8: Eve's optimal information gain per qubit in function of the mean photon number $|\alpha|^2$ that she can collect without being detected by Alice and Bob. The upper curve corresponds to eq. (1), the lower curve to the case that Alice and/or Bob applies phase randomization, eq. (11). For example, if Alice's monitoring detector sets a limit to Eve's backscattered signal of 0.1 photon, then Eve may gain 0.135 and 0.095 bits if Alice doesn't apply or applies phase randomization, respectively.

auxiliary state held by Eve. We like to show that phase randomization, as presented in the previous section, together with the effect of strong attenuation on the photon number statistics, as presented in section IV, allows one to reduce the security analysis of 2-way quantum cryptography systems to that of 1-way systems, like those analyses in [7, 8, 9, 10]. Formally, phase randomization separates Eve's state ψ into a mixture of Fock number states:

$$\begin{aligned} \rho_{rand.ph.} &= \int \frac{d\Phi}{2\pi} \sum_{n,m \geq 0} e^{i\Phi(n-m)} c_n c_m^* |n\rangle \langle m| \\ &= \sum_{n \geq 0} |c_n|^2 |n\rangle \langle n| \end{aligned} \quad (12)$$

Next, denoting t the transmission coefficient of Alice's apparatus (go and return), one has:

$$\rho_{rand.ph.Att.} = \sum_{m \geq 0} |q_m|^2 |m\rangle \langle m| \quad (13)$$

where

$$|q_m|^2 = t^m \sum_{n \geq m} \binom{n}{m} |c_n|^2 (1-t)^{n-m} \quad (14)$$

Accordingly, the probability of a multi-photon pulse is:

$$Prob(m \geq 2) = \ll n(n-1) \gg \frac{t^2}{2} + O(t^3) \quad (15)$$

where $\ll \dots \gg$ denote the average. For a coherent input state ψ , one recovers: $Prob(m \geq 2) = \frac{\ll n^2 \gg t^2}{2} = \frac{\mu^2}{2}$. For a Fock state $\psi = |N\rangle$, one obtains, possibly surprisingly, a lower multi-photon probability: $Prob(m \geq 2) = (N^2 - N) \frac{t^2}{2} < \frac{\mu^2}{2}$.

Note again that the phase randomization separates Alice from any possible reference-system that Eve might have prepared. Consequently, provided Alice randomizes the global phase of each qubit, measures the incoming intensity of each pulse and introduces sufficient attenuation, she can bound the probability of she sending a multi-photon pulse to Bob; hence Alice and Bob can apply the standard security proofs to their 2-way system.

VIII. CONCLUSION

Trojan horse attacks should be considered for every QKD systems. These include single-photon, weak laser pulses and continuous variable implementations, as all necessarily include a quantum channel that "enter" into the legitimate users apparatuses. Note that for single-photon sources, Alice doesn't use any attenuator, contrary to the weak pulse implementations. Hence, Trojan horse attacks are especially dangerous for such single-photon systems. For the Plug-&-Play system, the amount of reflected light is larger than for most alternative systems. Hence, the pressure on Eve's attacking system is reduced.

To counter such attacks, all QKD apparatuses should be properly designed, with filters and carefully designed timing. Additionally, auxiliary monitoring detectors must be implemented, if not the QKD system is insecure, irrespective of the quality of the source. Note that for the Plug-&-Play systems, first presented in [19], Alice does already have such an auxiliary detector.

The accuracy of this monitoring detector determines how much privacy amplification has to be applied in order to defeat Trojan horse attacks. In section VI we presented a simple way to reduce this amount, hence to achieve larger secret keys.

Acknowledgment

Discussions with Michele Mosca, Hoi-Kwong Lo and Norbert Lütkenhaus stimulated this research. This work has been supported by EC under project SECOQC (contract n. IST-2003-506813).

-
- [1] N. Gisin, G. Ribordy, W. Tittel, and H. Zbinden, *Reviews of Modern Physics*, **74**, 145 (2002).
- [2] D. Mayers, in *Advances in Cryptology — CRYPTO 1996*, LNCS **1109**, pp. 343–357, Springer (1996).
- [3] E. Biham, M. Boyer, P. O. Boykin, T. Mor, and V. Roychowdhury, in *Proceedings of the 32nd Ann. ACM Symposium on the Theory of Computing*, ACM press, pp. 715–724 (2000).
- [4] P. W. Shor and J. Preskill, *Phys. Rev. Lett.* **85**, 441, (2000).
- [5] H.-K. Lo, *QIC* **1**, 2 (2001).
- [6] R. Renner, N. Gisin and B. Kraus, [quant-ph/0410215](https://arxiv.org/abs/quant-ph/0410215) and [quant-ph/0502064](https://arxiv.org/abs/quant-ph/0502064).
- [7] H. Inamori, N. Lütkenhaus and D. Mayers, *Unconditional security of practical QKD*, [quant-ph/0107017](https://arxiv.org/abs/quant-ph/0107017), 2001.
- [8] D. Gottesman, H.-K. Lo, N. Lütkenhaus and J. Preskill, *Quant. Info. Comput.* **4**, 325, 2004.
- [9] K. Tamaki and H.K. Lo, [quant-ph/0412035](https://arxiv.org/abs/quant-ph/0412035), 2004.
- [10] M. Koashi, [quant-ph/0507154](https://arxiv.org/abs/quant-ph/0507154), 2005.
- [11] B. Huttner, N. Imoto, N. Gisin and T. Mor, *Phys. Rev. A* **51**, 1863, 1995.
- [12] G. Brassard, N. Lütkenhaus, T. Mor and B.C. Sanders, *Phys. Rev. Lett.* **85**, 1330, 2000.
- [13] W.-Y. Hwang, *Phys. Rev. Lett.* **91**, 057901 (2003)
- [14] V. Scarani, A. Acin, G. Ribordy, and N. Gisin, *Phys. Rev. Lett.* **92**, p. 057901 (2004).
- [15] M. Koashi, *Phys. Rev. Lett.* **93**, 120501, 2004.
- [16] E-G. Neumann, *Single-Mode Fibers, Fundamentals*, Ch. 13.4, Springer Series in Optical Sciences **57**, 1988.
- [17] M. Wegmuller, F. Scholder and N. Gisin, *J. Lightwave Tech.* **22**, 390, 2004.
- [18] G. Mussi, R. Passy, J-P. Von Der Weid and N. Gisin, *J. Lightwave Techno.* **15**, 1-11, 1997.
- [19] A. Muller, N. Gisin, T. Herzog, B. Huttner, W.Tittel and H. Zbinden, *Applied Phys. Lett.* **70**, 793-795, 1997.
- [20] G. Ribordy, J.D. Gautier, N. Gisin O. Guinnard and H. Zbinden, *Electron. Lett.* **34**, 2116-2117, 1998.
- [21] J.P. Von Der Weid, R. Passy and N. Gisin, *Photon. Tech. Lett.* **9**, 1253-1255, 1997.
- [22] A. Peres, “Quantum Theory: Concepts and Methods”, Kluwer Academic Publishers, Dordrecht (1993).
- [23] This is similar to H.-K. Lo and J. Preskill, [quant-ph/0504209](https://arxiv.org/abs/quant-ph/0504209), though there the authors did not consider Trojan horse attacks.
- [24] i.e. assuming that the legitimate users do properly apply the rules of the game, in particular that they apply enough privacy amplification and interrupt the communication in case the detect noise (i.e. a potential eavesdropper) is too strong to be dealt with by privacy amplification.
- [25] We consider the door as open only during the time when it potentially gives access to some useful information, the rest of the time the apparatus will merely backscatters a useless signal.
- [26] Every physicist knows that there must be some limit, Eve can’t pulse a KJ in an atto-second pulse. At some point, a too large energy concentration should cause the devices to explode, melt or particle pair production starts some nuclear reaction! But this is hard to quantify. Admittedly, the larger the attenuator, the better.