

Authentication and routing in simple Quantum Key Distribution networks

Andrea Pasquinucci

UCCI.IT, *via Olmo 26, I-23888 Rovagnate (LC), Italy*

June 02, 2005

Abstract

We consider various issues which arise as soon as one tries to practically implement simple networks of quantum relays for QKD. In particular we discuss authentication and routing which are essential ingredients of any QKD network. This paper aims to address some gaps between quantum and networking aspects of QKD networks usually reserved to specialist in physics and computer science respectively.

1 Introduction

Until now quantum key distribution (QKD) [1, 2] has mainly been considered a point-to-point link between Alice and Bob. However, recently, together with the arrival on the market of the first commercial products, discussion has started on how to form quantum key distribution networks. Here we are not considering theoretical networks where one can imagine using distributed multipartite entanglement and prolong the distance with entanglement swapping, but practical networks which can be implemented with today's technology.

In this paper we consider networks such as those introduced in ref. [3] (see also ref. [4] for some unpublished results), where a trusted quantum relay is basically performing the well-known intercept/resend eavesdropping strategy [5], but is cooperating with Alice and Bob. By means of such trusted quantum relays, it is possible to create simple networks for Quantum Key Distribution.

In this paper we consider two, more practical, issues which arise as soon as we form such a QKD network. The first is the problem of *Authentication*. Indeed QKD requires Alice and Bob, and in our case also the trusted relay, to exchange messages on a classical channel. We will discuss the possibilities and different strategies which arise in authenticating such classical communications.

The second issue is that of *Routing*. This follows from the possibility of having networks in which QKD could be run by using more than one intermediate relay.

Different routes, i.e. intermediate relays, could exist to reach Bob, and there must exist a way of choosing the more appropriate among them.

This paper aims to bridge two different fields, which often adopt different terminologies, that of quantum physics, and in particular quantum information theory and quantum cryptography, and that of computer science, in particular networking and its security. As such an effort has been done to adopt a language understandable by both and to blend results from the two fields.

The paper is organized as follows: In section 2, we recall the protocol introduced in ref. [3] and discuss various issues related to the authentication of the classical channel. In section 3, we discuss some very basic issues of routing in QKD networks indicating the main problems which we believe are still open. In section 4 we point out how the initial authentication of the participants to a QKD network, including the relays, could be implemented in different ways depending on the security requirements imposed. In section 5 we conclude with some final remarks.

2 QKD networks and authenticity of the classical channel

Let's start by considering the simplest QKD setup with a trusted quantum relay. In the simplest protocol (see ref. [3]) the relay acts practically doing an intercept/resend strategy to forward qubits¹ sent by Alice to Bob. At the end Trent, the relay, announces to Alice and Bob the basis he has used for each qubit. His participation in the protocol ends here.

Obviously, Trent, Alice and Bob need to use a classical channel of communication which guarantees to them that messages exchanged between all three are not modified by Eve nor that Eve can inject fake messages in the channel.² We say that the messages sent on the classical channel by Alice, Bob and Trent are authenticated and integral. *Authenticity* and *Integrity* of a classical communication channel can be obtained with standard classical cryptographic algorithms. For our purposes it is important to stress that Authenticity requires Alice, Bob and Trent to share some secret keys to prove that they are the source of the information. For this reason often QKD is called a *key extension protocol*, since to run QKD Alice and Bob, and in our case also Trent, need to start with some secret keys already shared. Usually the new key produced by QKD will be partly used to encrypt the secret data that Alice (Bob) wants to send to Bob (Alice), and partly used to refresh the shared keys for the authentication.

We want to stress a point which can lead to some confusion. In our setup, a Quantum Key Distribution protocol is run to create in a secure way a *secret key* shared by Alice and Bob. This secret key will be then used by Alice (Bob) to encrypt some data for Bob (Alice) using classical algorithms like 3DES, AES or OTP. Thus, from our point of view, QKD is used only to create such a secret key and we will

¹A computer scientist can safely assume that a qubit is practically realized with a single photon.

²Usually it is assumed that Eve can attack in any way she wants the QKD quantum channel but that she can only passively eavesdrop on the QKD classical channel.

not discuss how such a key will be used by Alice and Bob. In running a QKD protocol, Alice, Bob and Trent need to exchange some information on a classical channel, and in this paper when we discuss classical communications between them, we always consider the communications needed to run the QKD protocols, and not the exchange of secret data between Alice and Bob.

To run the protocol, Alice, Bob and all Trents need to share beforehand some secret authentication keys. These keys need to be substituted after their use, how often depends on the classical authentication algorithm adopted. To refresh the authentication keys, Alice, Bob and all Trents can use part of the keys created by running QKD. As we will see, in our case the keys generated by QKD between two participants, one of which is a Trent, can be used fully to refresh the corresponding authentication keys. Instead the authentication key between Alice and Bob should be extracted (subtracted) from their final secret key.

An important point in practical implementations is that the rate of refreshment of the authentication keys must be compatible with the rate of creation of new keys by QKD. In our case this means that for authentication keys involving at least one Trent, the rate of refreshment must be at most equal to the rate of creation of the corresponding QKD key. Instead the rate of refreshment of the authentication key shared between Alice and Bob, must be much lower than the rate of creation of the corresponding QKD key, otherwise there will not be any key left that Alice and Bob can use to encrypt their secret data. In this paper we will not consider any particular implementation of the authentication scheme.

Thus in our situation, there are two possible cases for the secret authentication keys shared between the participant before QKD is started:

1. Alice and Bob share each a secret authentication key with Trent
2. Alice and Bob share each a secret authentication key with Trent, and Alice shares a secret authentication key with Bob.

In both cases Alice and Bob must share a secret authentication key each with Trent, and thus need to refresh these keys once they have been used. The simplest way they can do this is by running a QKD protocol also with Trent and use the resulting secret key to authenticate the classical channel. In ref. [3] it has been shown that by involving Trent in the error correction and privacy amplification phases of the protocol, it is possible to create out of the same raw data, three keys, one shared between Alice and Trent, one shared between Trent and Bob, and one shared between Alice, Bob and possibly Trent.

Since Trent is now an active part in the protocol, and shares both classical and quantum keys with Alice and Bob, he does not play anymore the role of trusted arbitrator, but becomes a full member of the quantum protocol. For this reason, and following ref. [3], we prefer to call her Carol.

For clarity, we repeat here the full protocol.

1. Alice prepares a qubit in one of the four states $\pm x$ or $\pm y$, and sends it to Carol
2. Carol measures, as if she was Bob, in either the X or the Y basis. According to the result of this measurement, she prepares the same state that she found in this measurement and sends it to Bob.

3. Bob measures again in the X or the Y basis.
4. Alice, Carol and Bob repeat the first 3 steps many times.
5. Alice, Carol and Bob announce to each other which basis they used, and they divide the qubits in four groups:
 - (a) the first group is the one of the qubits for which Alice, Carol and Bob used the same basis; Alice and Bob, on the qubits of this group, proceed with the estimate of the error rate followed by error correction and privacy amplification to obtain a secret key — as in the standard BB84 protocol.
 - (b) the second group is the one of the qubits for which Alice and Carol used the same basis but Bob the opposite one; Alice and Carol, on the qubits of this group, proceed with the estimate of the error rate followed by error correction and privacy amplification to obtain a secret key.
 - (c) the third group is the one of the qubits for which Bob and Carol used the same basis but Alice the opposite one; Bob and Carol, on the qubits of this group, proceed with the estimate of the error rate followed by error correction and privacy amplification to obtain a secret key.
 - (d) the fourth group is the one of the qubits for which Alice and Bob used the same basis but Carol the opposite one; this group cannot be used.

In this way, 3 secret keys are created, one between Alice and Bob which Carol can reconstruct since she has the same raw data; one between Alice and Carol, and one between Bob and Carol.

Notice that in the protocol we have presented, Carol does not participate in the error correction and privacy amplification phases with Alice and Bob on the qubits of group (a). As discussed in ref. [3], if Carol follows the public discussion between Alice and Bob, she will be able to obtain a final secret key very similar, but usually not identical, to the one of Alice and Bob. The reason for this are few experimental errors or errors induced by Eve, that Carol is not able to correct. In any case, the knowledge on the final key shared between Alice and Bob that Carol can obtain by listening to the public discussion between them, is very large and cannot be reduced. So it should be assumed that Carol can always in practice learn the secret key shared by Alice and Bob.

The secret keys Alice-Carol and Bob-Carol can be fully used to authenticate the communication channel. As for the keys between Alice and Bob, as we said there are two possibilities:

1. Alice and Bob do not share any secret authentication key and rely on Carol for the authentication; thus in this case every classical message sent by Alice to Bob (and vice-versa), is received by Carol who verifies its authenticity and integrity, and then sends it to Bob (or Alice) adding her own authentication code; notice that in this case Bob (or Alice) verifies the authentication code of Carol, and not the one of the true sender of the message (see fig. 1).³

³In this and in the following Figures the "message" is a classical message of a phase of the QKD protocol, for example to realize the sifting procedure, and not the secret data that Alice wants to send to Bob.

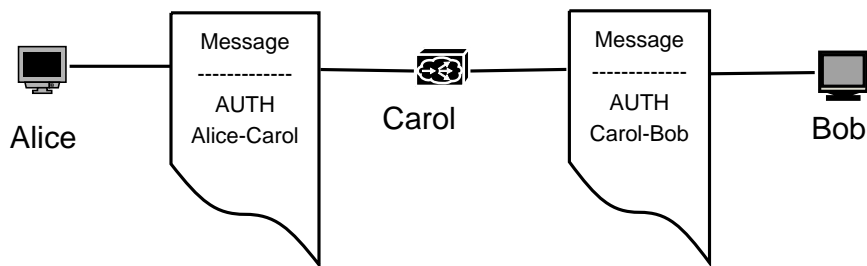

Figure 1: Authentication codes on a classical message exchanged between Alice and Bob when they share an authentication key only with Carol

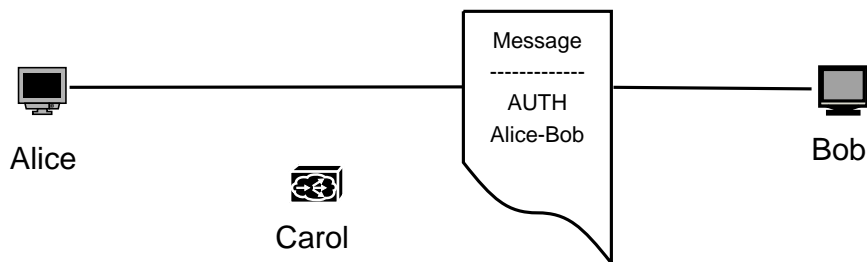

Figure 2: Authentication codes on a classical message exchanged between Alice and Bob when they share an authentication key

2. Alice and Bob share some classical secret authentication key and use it to generate the authentication code added to the classical messages which they exchange without any intervention by Carol; as we said, in this case part of the final secret key created by QKD between Alice and Bob must be used for this task (see fig. 2).

Of course these two cases have both points in their favor and against. If Alice and Bob do not share any authentication key:

- Alice and Bob depend on Carol also for their classical communications of the QKD protocol (notice anyway that in our QKD protocol Alice and Bob must in any case exchange classical messages with Carol)
- Carol has to do more work since she has to verify the authentication code for each message she receives and add her own to the message before sending it
- Alice has not direct confirmation of Bob's identity, and vice-versa
- no part of the QKD final secret key created between Alice and Bob is used for authenticating the classical channel
- the level of trust on Carol by Alice and Bob does not really change, since theoretically in any case Carol could practically learn the final QKD secret key shared between them.

Instead, if Alice and Bob share a secret authentication key:

- Alice and Bob can send directly to each other the authenticated classical messages of the QKD protocol without need of Carol relaying and authenticating the messages
- Carol has less work to do since she does not need to relay and authenticate Alice-Bob messages
- Alice has direct confirmation of Bob's identity, and vice-versa
- part of the QKD key created between Alice and Bob is used for authenticating the classical channel thus decreasing the final rate of creation of the secret key shared by Alice and Bob
- the level of trust on Carol by Alice and Bob does not increase, since theoretically in any case Carol could practically learn the final QKD secret key shared between them.

3 QKD networks and routing

As soon as there are networks, the problem of routing arises. In the simplest case we can pose the problem as follows. Suppose that there is a simple network with one Alice, a few Bobs and one Carol. Alice and the Bobs are all connected to Carol. How can Alice inform Carol to which Bob she wants to connect?

With more complex networks, not only Alice should tell the Carol she is connected to, but the first Carol should also know to which second (third etc.) Carol the final Bob is connected to. Thus it is necessary to have at least three elements:

1. a classical communication protocol between Alice, Carol and Bob to be able to exchange the informations needed to establish the *route* between them
2. some kind of *routing tables* held by Carol which permits her to know how to reach all Bobs
3. a dynamical protocol which allows to modify these tables when Bobs are added/removed to/from the network.

It could be useful to add a comparison with a network well known to everybody, the public Internet. When for example we *surf on the web* the following happens:

1. the *name* of the web site we want to reach, for example `lanl.arxiv.org`, is translated in the address `204.121.6.57` of the web server using a protocol called *Domain Name System* (DNS) [6]
2. the request for the page is sent to the address of the web server using the *Internet Protocol* (IP) [7], this protocol specifies how addresses are formed and how data is formatted and transmitted
3. the IP protocol also specifies the form of the routing tables and how data is routed by the *gateways* or *routers*, i.e. the devices which play the role of the relay between the sender and the receiver of the data

4. the *Border Gateway Protocol* (BGP) [8] specifies how the routing tables are updated in real-time so that all gateways/routers are always able to send the data along the shortest and loop-free path.

For QKD networks like the ones described in this paper and in ref. [3], it will be necessary to adopt or create protocols to fulfill similar tasks. The IP and related protocols cannot be adopted as they are, since they lack practically any security feature. It is instead fundamental that all communications and informations exchanged in a QKD network are trusted and verified.

A detailed formulation of protocols of this kind is beyond the scope of this paper. Below instead we will make some general considerations on the properties and characteristics of such protocols.

First of all, the main goal of such protocols is to allow Alice and Bob to create a secret key using a QKD protocol. Thus Alice and Bob should be certain of the identity of each other. Moreover, since the relays we use can practically learn the secret keys, they must trust them. So in a large network, Alice and Bob could require to accept or select the relays through which their communications, both quantum and classical, will pass.

Here we assume for simplicity that both quantum and classical communications between Alice and Bob follow the same route and pass through the same relays. This assumption seems to be reasonable when considering networks since it is certainly impractical to have different networks for the quantum and classical phases of the QKD protocol. Anyway there could be situations where the classical and quantum data exchanged between Alice and Bob follow two different paths; we will not consider further this scenario in this paper.

We should stress that Alice and Bob can not verify a priori through which relays their qubits will pass. Indeed a relay could route the classical communications through one path and the qubits through a different one without Alice and Bob noticing it at the moment. Of course, since the relays participate in the sifting procedure, Alice and Bob will realize a posteriori which route the qubits have followed by checking which relays are announcing the basis chosen for each qubit.

To make our discussion more practical, let's consider the network topology described in ref. [3] and in Figure 3. In this case all Carols are connected to each other, thus Alice to reach any Bob should pass through one or two Carols. We consider the case in which the path between Alice and Bob is Alice, Carol-1, Carol-2 and Bob.

As we have discussed in the previous section, Alice always shares an authentication key with Carol-1 to authenticate the classical channel between them, and Bob shares an authentication key with Carol-2.

Analogously Carol-1 and Carol-2 share an authentication key that they use to authenticate their communications. In particular the two Carols need to inform each other of the Alices and Bobs that are connected to them. Indeed the *routing tables* held by our Carols contain the list of Alices and Bobs connected to each one of them, and all Carols need to exchange classical communications to keep these tables updated.

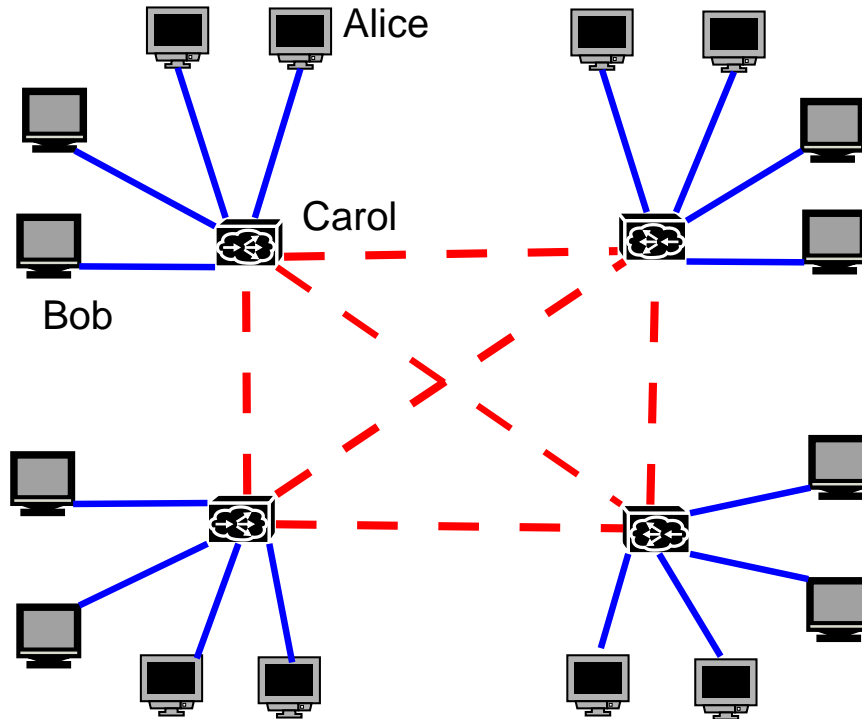

Figure 3: A simple network with Star topology between Alices and Bobs with Carols as centers, and Full-Mesh between Carols

As in the previous section, the refreshing of the authentication keys shared between any two members of the QKD network, can be extracted from parts of the raw data not used to form the QKD secret key between Alice and Bob. In our case study, from the raw data it can be extracted: an authentication key between Alice and Carol-1, an authentication key between Alice and Carol-2, an authentication key between Carol-1 and Carol-2, an authentication key between Carol-1 and Bob, an authentication key between Carol-2 and Bob, plus the key between Alice and Bob. Moreover, if needed, the authentication key between Alice and Bob must be extracted from their QKD final key. In total $7/8$ of the raw data is used to create secret keys.

Consider then when Alice wants to start a QKD with Bob. First Alice has to establish a route to Bob, and Bob has to accept to run the protocol. Thus Alice sends her request, an authenticated classical message, to Carol-1. Carol-1 first checks in her routing tables if Bob is directly connected to her, otherwise she finds to which Carol is Bob connected and sends the message to Carol-2 who forwards it to Bob. Bob should reply, accepting to run a QKD protocol with Alice, sending an authenticated classical message back through the same route. In the same way the participants exchange authenticated classical messages for the synchronization of the various phases of the QKD protocol, the messages of sifting, error correction and privacy amplification, and the final messages for ending the QKD run.

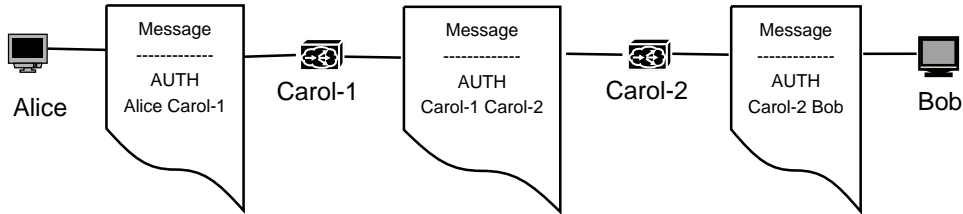

Figure 4: Step by step authentication codes on a classical message exchanged between Alice and Bob.

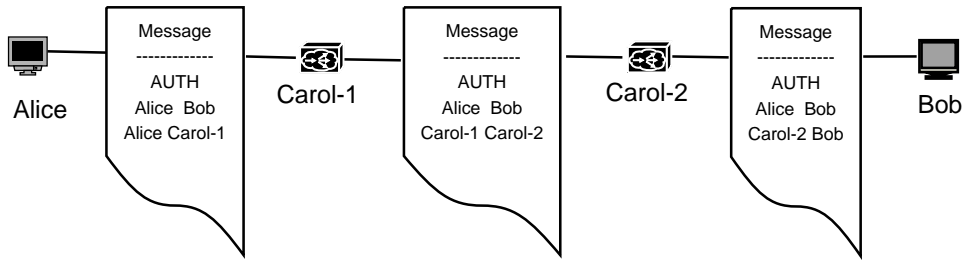

Figure 5: Authentication codes on a classical message exchanged between Alice and Bob when they share an authentication key.

One important point is how Alice and Bob should authenticate. In the simplest case, Alice shares a classical key only with Carol-1, and verifies only the authentication codes by Carol-1. This means that all classical messages sent by Carol-2 for the sifting, and Bob through Carol-2 to Alice, are received by Carol-1 who verifies the authentication code and if correct, resends them to Alice with her own authentication code. In this way, authentication is added and verified step by step on the route, i.e. only locally, and Alice has to fully trust Carol-1 on the identity and authenticity of Carol-2 and Bob (see fig. 4). Thus Alice in this case needs to share a classical key only with Carol-1.

Since at the end the important point is that Alice and Bob identify and authenticate each other, the previous case can be improved by having Alice and Bob share an authentication key and verify directly each other authentication codes (see fig. 5).

The most general case is the one in which Alice and Bob share a classical key also with all Carols and are then able to verify the authentication codes of everybody else. In practice in this case, whoever receives a classical message, verifies all authentication codes added to it, and adds his/her own authentication code before forwarding it (see fig. 6).

These three general situations are of increasing complexity and require more resources in turn. The more complex they are, the more layers of security they add to the authentication of the classical messages exchanged for routing and the phases of the QKD protocol.

At this level of analysis it is not clear if the simplest case is sufficiently secure.

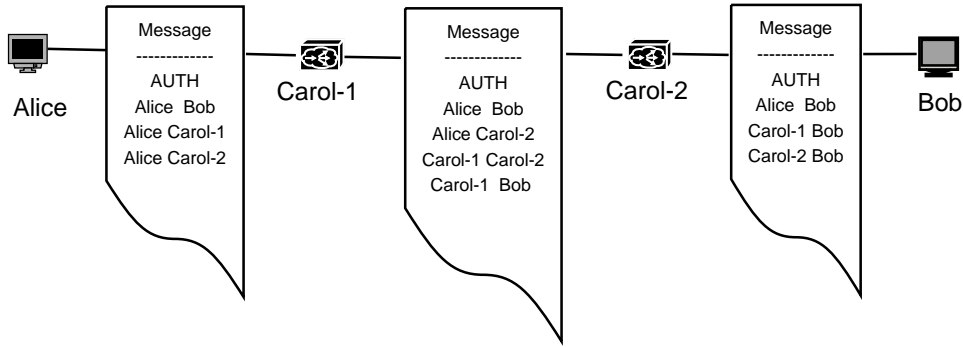

Figure 6: Authentication codes on a classical message exchanged between Alice and Bob when everybody shares an authentication key with everybody else.

This depends also on the level of trust and complexity of the network since there could be more general cases in which Alice and Bob do not want a particular Carol to be part of the route.

4 Initial Authentication in large networks

We have seen in the previous sections, that our networks require Alice at least to share an authentication key with the Carol she is connected to, and similarly for Bob. In principle it is not necessary for Alice to share a key with Bob before running QKD. Indeed consider the case of a large network, in this case all Carols have the list of all participants, which can be easily extracted by the routing tables. In other words, all Carols can act as directory services, some kind of *Telephone Directory* in which Alice can find a Bob to connect to. Using her authenticated classical channel with Carol, Alice can then ask her the list of Bobs available at any time.

To start a QKD with a Bob present in Carol's directory, Alice can adopt one of three general strategies, she can choose the one she prefers depending on the kind of communication she needs and the level of security of initial identification and authentication of the corresponding Bob.

The first and simplest case is when Alice relies entirely on Carol, thus she just shares a secret key with Carol and trust her completely on identifying and authenticating Bob (see fig. 4). Obviously every time Alice will run a QKD with the same Bob, she will trust entirely Carol and have no direct proof that she is communicating with the same Bob as the previous time.

The simplest improvement on this approach, which is adopted by many protocols in classical cryptography, is to trust Carol for the connection to Bob only the first time. Thus with the first run of the QKD protocol, Alice and Bob create a shared secret key but they do not use this key to encrypt some data, but they keep it as their authentication key. When Alice and Bob run again a QKD protocol they share an authentication key and they can authenticate directly each other. Thus in this case the first run of QKD has the special purpose to create a shared key for

future authentications. In this case, the first run of the QKD is like the one in fig. 4, whereas all the others like the one in fig. 5.

Obviously, this can be done not only between Alice and Bob, but also between Alice and Carol-2, and Bob and Carol-1.⁴ Thus the first run of the QKD protocol can be used entirely to create authentication keys between all participants in the communications so that after the first run of QKD the authentication codes can be like the ones in fig. 6.

The last approach to the initial distribution of authentication keys, is the one where Alice shares an authentication key with Bob, and in case with all other Carols, before starting any QKD. This key must be exchanged on a different channel, like person to person exchange of the key on a paper slip. Of course this case requires much more work for Alice to enlarge her QKD network, since the initial authentication phase requires some kind of out-of-band communication.

Notice that combining the possibility of creating shared authentication keys, with the possibilities of authentication of the classical messages exchanged during the QKD protocol described in the previous section, Alice and Bob have the possibility of fine tuning the level of control they want to apply on their classical communications. Notwithstanding all this, Alice and Bob must anyway trust all Carols, since in any case all Carols acting as relay for their communications could always practically learn the secret key that Alice and Bob generate with QKD.

5 Some final remarks

One of the peculiarity of QKD, is that Alice and Bob have different hardware boxes. In the simplest case, Alice sends a qubit (photon) whereas Bob receives it. Thus in some current implementations, Alice has a laser whereas Bob has a detector.⁵ In a network like the one in Figure 3, all Carols must implement both kinds of hardware, a Bob-like box facing Alice, and an Alice-like box facing Carol-2 or Bob.

If Alice has only an Alice-like box, it is impossible for her with the protocols considered in this paper, to run a QKD protocol with any other Alice in the network. The easy solution to this is to provide all Alices and Bobs with a double box, containing both the hardware of an Alice-like box and Bob-like box and with the possibility of acting as either of the two depending on the setup of the connection. In this way any participant in the network can run a QKD protocol with anyone else.

Since in any implementation of the BB84 protocol, the role of Alice and of Bob is similar, the presence of the trusted relays allows also Alice and Bob to have boxes from different manufacturers, adopting different implementations or distribution platforms (optical fibers or free space).

Finally, Alice can also create keys with two or more Bobs at the same time. The

⁴We assume that Carol-1 and Carol-2 already share an authentication key used to authenticated the messages they exchange for the routing.

⁵In the Plug&Play scheme both the laser and detector are at Bob's site; in any case still Alice and Bob boxes are different.

simplest way is to alternate (i.e. multiplexing), either qubit by qubit or run by run of the QKD protocol, the destination of the qubit. This can be done by time or wavelength multiplexing, that is by integrating the QKD networks discussed in this paper with multi-user QKD schemes which have been proposed to allow a single Alice to be directly connected to more than one Bob without any relay [9]. Of course in our case the multiplexing of the qubits sent by Alice for the various Bobs is coupled to the routing done by either Carol-1 or Carol-2, who should deliver the correct qubit to each Bob.

Acknowledgments

We thank H. Bechmann-Pasquinucci for inspiring remarks.

References

- [1] C. H. Bennett and G. Brassard, in Proceedings of the *IEEE International Conference on Computer, Systems and Signal Processing*, Bangalore, India (IEEE, New York, 1984), 175-179
- [2] N.Gisin, G.Ribordy, W.Tittel and H.Zbinden, Rev. Mod. Phys., **74**, 145 (2002), quant-ph/0101098
- [3] H. Bechmann-Pasquinucci and A. Pasquinucci, quant-ph/0505089
- [4] A. Karlsson, *Regenerative Quantum Cryptography*, KTH internal report ISRN KTH/MVT/FR-97/1-SE, ISSN 0348-4467, TRITA-MVT Report 1997:1 (available from andkar@imit.kth.se)
- [5] C. H. Bennett, F. Bessette, G. Brassard, L. Savail, J. Smolin, J. Cryptology, **5**, 3 (1992)
- [6] Domain Name System, RFC-1035 and RFC-1034 and updates from <http://www.rfc-editor.org/>
- [7] Internet Protocol, RFC-791 and updates from <http://www.rfc-editor.org/>
- [8] Border Gateway Protocol 4, RFC-1771 and updates from <http://www.rfc-editor.org/>
- [9] Paul D. Townsend, *Quantum Cryptography on Multi-user Optical Fibre Networks*, Nature, No. 385, 1997, pp.47-49; SJD Phoenix, SM Barnett, PD Townsend and KJ Blow, *Multi-user quantum cryptography on optical networks*, J.Mod.Opt. 6, 1995, pp.1155-1163