

Cyclostationary shot noise in mesoscopic measurements

Leif Roschier, Tero T. Heikkilä, and Pertti Hakonen

Helsinki University of Technology, Low Temperature Laboratory, P.O.BOX 2200, FIN-02015 HUT, Finland

We discuss theoretically a setup where a time-dependent current consisting of a DC bias and two sinusoidal harmonics is driven through a sample. If the sample exhibits current-dependent shot noise, the down-converted noise power spectrum varies depending on the local-oscillator phase of the mixer. The theory of this phase-dependent noise is applied to discuss the measurement of the radio-frequency single-electron transistor. We also show that this effect can be used to measure the shot noise accurately even in nonlinear high-impedance samples.

PACS numbers: 05.40.Ca

The dominating noise mechanism in mesoscopic samples at low temperatures is shot noise. In some cases, it is the limiting factor for the measurement sensitivity, but it may be the measured quantity itself as it, contrary to the thermal noise, contains information about the sample complement to that of the average current [1]. Many of the interesting predictions for noise have been obtained for nonlinear elements (with voltage-dependent response) whose resistance is typically in the range of $k\Omega$ or more. However, measurement of shot noise in such samples is not always straightforward as the excess noise added by the amplifiers depends on the sample impedance, and thus on the applied voltage. An important property of shot noise is that it is typically proportional to the average current. In this paper we exploit this property and show that with adiabatic cyclostationary driving, generalizing the treatment in Refs. [2, 3], one may modulate the noise by using a few first harmonics of the base frequency. We show that this can be used to improve the sensitivity of the radio-frequency single electron transistor (RF-SET) by some fraction. We also show that the use of the phase dependence of the noise allows the noise to be measured without a precise knowledge of the amplifier noise.

Throughout the paper we consider a situation illustrated in Fig. . We limit to the case where current $i(t) = I_0 + I_1 \sin(\omega_0 t) + I_2 \cos(2\omega_0 t) + n(t)$ flows through the sample. We assume that $\langle i(t) \rangle = I_0 + I_1 \sin(\omega_0 t) + I_2 \cos(2\omega_0 t) \equiv I(t)$ and noise $\langle n(t) \rangle = 0$. For a low enough driving frequency ω_0 , shot noise adiabatically follows the absolute value of the current. Moreover, in this low-frequency limit, the noise is white. This means that

$$2 \int_{-T/2}^{T/2} d\Delta t e^{-i\omega\Delta t} \langle n(t + \Delta t/2) n(t - \Delta t/2) \rangle = 2eF|I(t)|, \quad (1)$$

independent of the frequency ω . To account for a general shot noise source, we introduced the Fano factor F . Finite time Fourier transform of Eq. (1) with $e^{-i(\omega-\omega')t}$

yields

$$\langle \tilde{n}(\omega) \tilde{n}^*(\omega') \rangle = eF \tilde{I}_A(\omega - \omega'). \quad (2)$$

The terms $\tilde{n}(\omega)$ and $\tilde{I}_A(\omega)$ are defined using the finite time Fourier transforms: $\tilde{g}(\omega) \equiv \int_{-T/2}^{T/2} e^{-i\omega t} g(t) dt$ and $\tilde{g}_A(\omega) \equiv \int_{-T/2}^{T/2} e^{-i\omega t} |g(t)| dt$. It is assumed that $T = 2N\pi/\omega_0$, where $N \gg 1$ is an integer. Equation (2) is derived for a diode ($F = 1$) in the case $I(t) > 0$ in Refs. [2, 3] and the generalization to the case with arbitrary sign of $I(t)$ is straightforward.

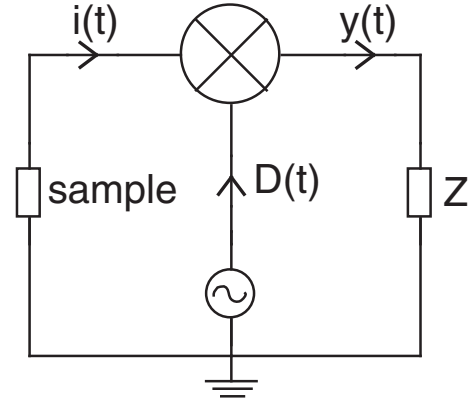

FIG. 1: The general setup. Current $i(t)$ flows through the sample. Output current is $y(t) = i(t) \times D(t)$, where $D(t) = D_0 \sin(\omega_0 t + \phi)$. It is converted into a signal voltage using detection circuitry.

The goal is to find the power spectral density $S_y(\omega) \equiv \lim_{T \rightarrow \infty} 2 \frac{\langle |y(\omega)|^2 \rangle}{T}$ for $y(t) = D(t) \times i(t)$, where $D(t) = D_0 \sin(\omega_0 t + \phi)$. The factor two accounts for the contributions of both negative and positive frequencies. By noting that

$$\tilde{y}(\omega) = \frac{D_0}{2i} \left[e^{i\phi} \left(\tilde{I}(\omega - \omega_0) + \tilde{n}(\omega - \omega_0) \right) - e^{-i\phi} \left(\tilde{I}(\omega + \omega_0) + \tilde{n}(\omega + \omega_0) \right) \right] \quad (3)$$

and by using Eq. (2), we find in the band $0 \leq \omega < \omega_0$

$$\langle \tilde{y}(\omega) \tilde{y}^*(\omega) \rangle = \frac{D_0^2}{4} \left\{ \frac{I_1^2}{2} (1 + \cos(2\phi)) |\delta_T(\omega)|^2 + F \left(2\tilde{I}_A(0) - e^{2i\phi} \tilde{I}_A(-2\omega_0) - e^{-2i\phi} \tilde{I}_A(2\omega_0) \right) \right\}, \quad (4)$$

where $\delta_T(\omega) = 1/2\pi \int_{-T/2}^{T/2} e^{-i\omega t} dt$. The first term in (4) is usually taken as the downconverted carrier for the signal and the other terms as noise. It is to be noted that only the DC and $2\omega_0$ components of $\tilde{I}_A(\omega)$ contribute to the noise. It is thus enough for the noise calculations to find the Fourier series expansion $|I(t)| \simeq I_{0A} + I_{1A} \sin(\omega_0 t + \theta_A) + I_{2A} \cos(2\omega_0 t)$, where I_{1A} and θ_A have no effect on the noise. By using (4) we find the power spectral density of the noise in the band $0 < \omega < \omega_0$

$$S_y(\omega) = eFD_0^2 \left[I_{0A} - \frac{I_{2A}}{2} \cos 2\phi \right]. \quad (5)$$

Equation (5) is the same as in Refs. [2, 3] except that we have defined it in terms of Fourier expansion coefficients I_{0A} and I_{2A} in order to handle alternating currents.

We first apply Eq.(5) to the analysis of the RF-SET, that is the most sensitive electrometer known today [4, 5]. In practice, its sensitivity is limited by the noise of the following amplifier [6]. In the near future when this noise will probably be reduced from a few Kelvin to ~ 100 mK [7] the charge sensitivity will be set by the shot noise of the tunnelling electrons through the single-electron transistor (SET) [8]. A metallic RF-SET is operated in two different modes: In the superconducting case the best sensitivity is achieved with DC bias. In the normal (non-superconducting) case the best sensitivity is obtained without the DC bias. In this latter case, the current $I(t)$ through the SET is given by $I_1 \sin(\omega_0 t)$ and we find $|I(t)| \simeq I_{0A} + I_{2A} \cos(2\omega t)$, where $I_{0A} = I_1/2\pi$ and $I_{2A} = -4I_1/(3\pi)$. The operation of the RF-SET is based on amplitude modulation, because the signal is due to the resistance variation in time. This means that the largest signal component comes out when $\phi = 0$ and the shot noise S_y is at maximum according to Eq. (5). In contrast, if the RF-SET could be operated in a phase variation mode such that the signal component would be in the $\cos(\omega_0 t)$ quadrature ($\phi = \pi/2$), then the shot noise contribution would be by a factor of two lower in power.

In the other measurement mode, the SET is DC biased and the current through it may be approximated by $I(t) = |I(t)| = I_0 + I_1 \sin(\omega_0 t) = I_{0A} + I_{1A} \sin(\omega_0 t)$. From Eq. (5) it follows that the noise is set by the I_0 component alone. Adding a component $I_2 \cos(2\omega_0 t)$ to the current, the measured noise power spectrum may be lowered by some fraction. If the signal component is negligibly affected by the $2\omega_0$ - component, the signal-to-noise ratio would also be enhanced.

In some cases, noise reveals additional information that cannot be extracted from IV curve measurements. For example, in the subgap regime of normal-insulator-superconductor contact, shot noise could be used as a

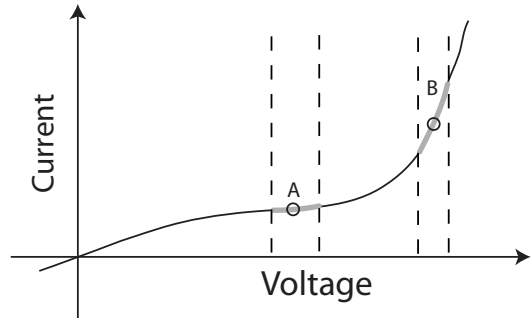

FIG. 2: An arbitrary nonlinear IV curve illustrating the problem of the noise measurements. Regions A and B have different impedances and the amplifier noise contribution to the total noise is different at these points. In $2\omega_0$ modulation, the sample is DC biased (marked by circles) and a signal $I_2 \cos(2\omega_0 t)$ is added (marked as gray area). By measuring the noise in both quadratures by varying mixer phase ϕ , one may extract the shot noise contribution to the total noise.

tool to determine whether conduction is due to quasiparticles (thermal excitation or leakage current) or due to Andreev reflection. However, noise measurements at low frequencies of such nonlinear high-resistance samples with conventional techniques are possible only with special care [9] provided that $1/f$ -noise is negligible. Alternatively, measurements have been carried out on very large samples in order to circumvent the problems [10]. A characteristic illustration is depicted in Fig. : IV curve is measured, but noise contribution of the sample cannot be extracted from the total measured noise. This is due to the dominating amplifier noise variation, that is difficult to know accurately, with respect to the sample impedance. In general, measurement of the shot noise in mesoscopic samples with high impedance levels (> 1 k Ω) is difficult due to the small signal levels.

In the following we propose a technique to use $2\omega_0$ modulation in order to measure the shot noise. By $2\omega_0$ modulation technique we mean a setup, where local oscillator signal in the mixer is of the form $D(t) = D_0 \sin(\omega_0 t + \phi)$ and there is a term $I_{2A} \cos(2\omega_0 t)$ in the absolute value $|I(t)|$ of the current through the sample. In order to avoid the $1/f$ noise, we discuss noise measurements at high frequencies, that is $f \sim 500$ MHz. In this frequency range the signal is carried in coaxial cables. The restricted cable size limits the characteristic impedance to values around $Z_0 \sim 50 \Omega$.

To be specific, we approach the problem by considering an example. If the shot noise is to be measured from a current of 100 pA assuming a Fano-factor F of unity,

the resulting noise corresponds to a delivered power of $T_S \sim 2eIZ_0$ to the preamplifier. This equals $100 \mu\text{K}$ in noise temperature. By using the Dicke radiometer formula [11] for the fractional error of the noise measurement $\Delta T/(T_N + T_S) \sim 1/\sqrt{B\tau}$, where τ is the measurement time and B the measurement bandwidth, it follows that with $\tau \sim 1 \text{ s}$ and $B \sim 10^8 \text{ Hz}$ the signal power of $100 \mu\text{K}$ may be measured if the amplifier noise temperature T_N is of the order of 1 K . The practical problem is that T_N depends in general considerably on the impedance of the measured source [6, 12]. In order to extract the shot noise contribution from the total measured noise, it would be necessary to know the four noise parameters of the amplifier [12, 13] and their effect to the measured total noise with an accuracy of 100 ppm . This is almost impossible in practice. One solution is to use a series of cryogenic isolators that have typically an isolation of 20 dB each. There is, however, the problem that below 1 GHz isolators are bulky to fit into the limited space of mK -cryostats.

The $2\omega_0$ modulation technique can be used to partially circumvent the problem considered above. As is obvious from Eq. (5), a change of the mixer local oscillator phase ϕ varies the measured shot noise power by an amount $\sim FeI_{2A}Z_0$ from the maximum to the minimum. This is an analogue of the lock-in scheme frequently applied for the measurement of the differential conductance. The point is that the (phase-insensitive) amplifier noise does not directly depend on ϕ , but only through the possible bias dependence of the sample impedance (which would make the amplifier noise contribution partially follow the driving). The latter effect can be reduced in the typically interesting limit where the sample impedance exceeds the amplifier impedance, through the use of a matching circuit whose characteristic impedance equals that of the amplifier. In this case, provided the sample impedance does not depend on the bias more strongly than the noise,

the modulation of the sample noise may be brought to dominate the environmental contribution to the phase-sensitive noise. The advantage compared to the direct measurement is that the contribution from the environment in this case depends only on the nonlinearity of the sample, whereas in the unmodulated measurement it is present even for linear samples. In order to compare the results of the noise measurement at different bias points, one needs to know the impedance of the sample at these points. This may be found out by measuring the reflection coefficient $\Gamma = \frac{Z-Z_0}{Z+Z_0}$ of the sample, where Z is the sample impedance and Z_0 the reflected wave impedance. In general, the total gain of the system is not known accurately and it often varies on a time-scale of hours. Therefore, the measurement produces a differential result $dS_y/dI_{2A} = GF(I_{0A})$ of the possibly bias-dependent Fano factor $F(I_{0A})$ with one unknown multiplicative gain factor G . If there is, however, one measured point that has a well established result, for example $F = 1$ as is the case in typical tunnelling structures at high voltages, the measurement result at this point can be used as a calibration to extract gain G , and the Fano factor can be found out over the whole measurement range.

As a conclusion, we have discussed the theory of a doubly modulated shot noise. We applied the outcome, Eq. (5), to the zero DC bias RF-SET and concluded that there is by a factor two more noise in the in-phase quadrature than in the out-of-phase quadrature. We suggested the use of the $2\omega_0$ modulation in order to reduce shot noise by some fraction in the case of the DC biased RF-SET. We also argued that the $2\omega_0$ modulation may be used to extract the shot noise contribution from the total noise. This may be applied, e.g., to determine Fano factors from high-impedance samples at current levels below 1 nA using an amplifier with noise temperature $T_N \sim 1 \text{ K}$, a measurement bandwidth of 10^8 Hz , and a measurement time of 1 s .

-
- [1] Y. M. Blanter and M. Büttiker, *Phys. Rep.* **336**, 1 (2000).
 [2] T. Niebauer, R. Schilling, K. Danzmann, A. Rüdiger, and W. Winkler, *Phys. Rev. A* **43**, 5022 (1991).
 [3] M. Rakhmanov, *Appl. Opt.* **40**, 6596 (2001).
 [4] R. Schoelkopf, P. Wahlgren, A. Kozhevnikov, P. Delsing, and D. Prober, *Science* **280**, 1238 (1998).
 [5] A. Aassime, G. Johansson, G. Wendin, R. Schoelkopf, and P. Delsing, *Phys. Rev. Lett.* **86**, 3376 (2001).
 [6] L. Roschier, P. Hakonen, K. Bladh, P. Delsing, K. Lehnert, L. Spietz, and R. Schoelkopf, *J. Appl. Phys.* **95**, 1274 (2004).
 [7] M.-O. André, M. Mück, J. Clarke, J. Gail, and C. Heiden, *Appl. Phys. Lett.* **75**, 698 (1999).
 [8] A. N. Korotkov and M. A. Paalanen, *Appl. Phys. Lett.* **74**, 4052 (1999).
 [9] R. Cron, M.F.Goffman, D. Esteve, and C. Urbina, *Phys. Rev. Lett.* **86**, 4104 (2001).
 [10] F. Lefloch, C. Hoffmann, M. Sanquer, and D. Quirion, *Phys. Rev. Lett.* **90**, 67002 (2003).
 [11] R. Dicke, *Rev. Sci. Instrum.* **17**, 268 (1946).
 [12] H. Rothe and W. Dahlke, *Proc. IRE* **44**, 811 (1956).
 [13] J. Engberg and T. Larsen, *Noise Theory of Linear and Nonlinear Circuits* (John Wiley, New York, 1995).