

A new mechanism of exchange interaction in ferromagnetic semiconductors

V. K. Dugaev^{1,2,†}, V. I. Litvinov³, J. Barnaś⁴, and M. Vieira¹

¹*Department of Electronics and Communications, Instituto Superior de Engenharia de Lisboa,
Rua Conselheiro Emidio Navarro, 1949-014 Lisbon, Portugal*

²*Institute for Problems of Materials Science, Vilde 5, 58001 Chernovtsy, Ukraine*

³*WaveBand Corporation, 375 Van Ness Avenue, Suite 1105, Torrance, California 90501*

⁴*Department of Physics, Adam Mickiewicz University, ul. Umultowska 85, 61-614 Poznań, Poland, and
Institute of Molecular Physics, Polish Academy of Sciences, ul. M. Smoluchowskiego 17, 60-179 Poznań, Poland
(November 20, 2018)*

We propose a new mechanism of indirect exchange interaction, which can be responsible for the ferromagnetic ordering in Mn-doped semiconductors (like GaMnAs) at low carrier concentration. The mechanism is based on the interplay of the hybridization of band states (conduction or valence) with localized impurity (donor or acceptor) states and the direct exchange interaction between localized spins and the band states. The indirect exchange coupling between two impurities occurs when the wavefunctions of the corresponding localized donor (acceptor) states overlap. This coupling is independent of the free carrier concentration and therefore may be responsible for ferromagnetic transition at low or vanishing carrier concentration.

75.50.Pp, 72.80.Ey, 75.50.Dd

Recent progress in controlling spin-polarized electron transport in metallic magnetic structures, and successful applications of such systems in magnetoelectronics/sprintronic devices¹ renewed worldwide interest in ferromagnetic semiconductors (FMS's). Experimental efforts are mainly focused on searching for FMS's with the ferromagnetic transition occurring above the room temperature. Current achievements, however, are still far from this objective. The most promising now seem to be III-V semiconductors doped with Mn atoms (diluted magnetic semiconductors). Recently, ferromagnetic transition at about 110 K was observed in GaMnAs,^{2,3} and this observation stimulated further theoretical and experimental works aimed at understanding the origin and nature of the transition.^{4,5}

It is commonly believed^{6,7} that the leading mechanism of magnetic coupling between Mn²⁺ ions, which leads to ferromagnetic phase transition, is the Rudermann-Kittel-Kasuya-Yosida (RKKY) indirect exchange interaction *via* the band carriers⁸ (holes in the case of GaMnAs). However, this mechanism does not explain the occurrence of ferromagnetism at low or vanishing density of free carriers in GaMnAs.² Therefore, other mechanism(s) of magnetic coupling between Mn ions is (are) expected to be responsible for ferromagnetism at low carrier concentrations. Inoue *et al*⁹ proposed a mechanism based on the coupling *via* resonant states due to Mn impurities, which can form for one spin orientation (more specifically for minority spins) close to the top of the valence band. This mechanism may lead to ferromagnetism at low carrier concentration (also in the insulating phase). The resonant states are formed from the *d*-states owing to the *p-d* hybridization. However, there is no clear evidence of such resonant states in GaMnAs.

Recently, another mechanism of exchange interaction

between Mn impurities was proposed, which also may lead to ferromagnetism at low carrier concentration.¹⁰ The mechanism was based on a modified version of the Bloembergen-Rowland type of exchange coupling, in which virtual transitions between the valence band and the impurity acceptor band were involved. This model explicitly takes into account the presence of an impurity acceptor band, which in the case of GaMnAs is formed near the top of the valence band. In Ref. [10] the impurity band was approximated by a very narrow band corresponding to large effective electron mass and located above the valence band. However, position of the Mn acceptor states in GaMnAs is not well established. It is generally believed that the Mn impurities in GaMnAs act as acceptors (*d*⁵ + hole). At low impurity concentrations the holes are weakly bound to the Mn impurities, leading effectively to an impurity acceptor state above the valence band. When the Mn concentration increases, the impurity acceptor band merges with the valence band.⁴ In that case the holes may propagate as quasi-free quasiparticles. Owing to their exchange coupling to the localized moments of the Mn impurities, they give rise to RKKY indirect exchange interaction.

In this paper we propose a new mechanism of indirect exchange coupling, in which the localized impurity levels (donor or acceptor states) are involved. The main point of the model is the interplay of the following two interactions: (i) direct exchange coupling of the band (conduction or valence) states to localized spins, and (ii) hybridization of the localized donor (acceptor) states with the conduction (valence) band states. The indirect exchange coupling between two localized spins is then mediated *via* the localized impurity states. This takes place when the wavefunctions of the of the impurity states localized at different sites overlap. Thus, the mechanism

may be relevant when the characteristic size of the wavefunctions corresponding to the localized donor or acceptor states is much larger than the characteristic size of the wavefunctions corresponding to the localized spins (d -states). If this is the case, the direct coupling between two spins is negligible. When additionally the RKKY mechanism is not applicable (e.g., the Fermi level is in the gap), the indirect coupling *via* donor or acceptor states may be dominant.

Let us analyse now the exchange coupling between magnetic impurities more quantitatively. In the following we will consider the situation, when a localized magnetic moment associated with each impurity is due to the unfilled d -shell. Apart from this, we assume that each impurity gives rise to a localized impurity (donor or acceptor) state that is spin degenerate. The localized spin is coupled *via* direct exchange interaction to the band states. On the other hand, the band states are additionally hybridized with the localized donor or acceptor states. Owing to these two interactions, the information on the state of a localized spin is transmitted to the localized donor (acceptor) state (which is localized at the same lattice point as the corresponding spin). To take this into account, we extract from the total Hamiltonian the most important terms and write the relevant effective model Hamiltonian in the form:

$$H_{eff} = \sum_{\mathbf{k}} \psi_{\mathbf{k}}^{\dagger} \varepsilon_{\mathbf{k}} \psi_{\mathbf{k}} + \sum_i \psi_i^{\dagger} \varepsilon_i \psi_i + \frac{1}{\sqrt{N}} \sum_{\mathbf{k}, i} g_{\mathbf{k}} \left(\psi_{\mathbf{k}\mu}^{\dagger} \boldsymbol{\sigma}_{\mu\nu} \cdot \mathbf{S}_i \psi_{i\nu} + H.c. \right), \quad (1)$$

where \mathbf{S}_i is the spin localized at the point \mathbf{R}_i , N is the number of host atoms in the lattice, $\boldsymbol{\sigma}$ are the Pauli matrices, $\psi_{\mathbf{k}}$ and ψ_i are the spinor operators corresponding to the band electrons with the energy spectrum $\varepsilon_{\mathbf{k}}$ and to localized impurity states of energy ε_i , respectively. The first term describes the system of noninteracting band electrons, while the second one corresponds to localized impurity states (acceptor or donor states). The third term describes that contribution to the effective hybridization of the localized and band states, which depends on the localized spin \mathbf{S}_i . The other terms, which do not contribute to the indirect coupling between two localized spins, have been omitted in Eq. (1). In the third term $g_{\mathbf{k}}$ is an effective parameter that describes \mathbf{S}_i -dependent contribution to the effective hybridization of the band and donor (acceptor) states. This constant includes the effects due to direct exchange coupling between the localized moments \mathbf{S}_i and the band states, and can be derived *eg* by the perturbational methods. In the simplest second order approximation one finds $g_{\mathbf{k}} \approx Jg_0/\varepsilon_d$, where J is the parameter of direct exchange interaction between localized spins and band states, g_0 is the bare hybridization parameter of the band and localized states, and ε_d is the activation energy of the donor (acceptor) states.

The total spin of the localized magnetic moment (\mathbf{S}_i)

and of the delocalized (band states) and localized (donor or acceptor states) electrons is conserved. This condition can be used to eliminate some of the matrix elements of the effective Hamiltonian (1), which do not conserve the total spin. In Eq. (1) we assumed that all the non-vanishing matrix elements are equal and denoted them by $g_{\mathbf{k}}$.

Hamiltonian (1) describes individual magnetic ions (impurities) with the unfilled d -shell which is responsible for the localized spin \mathbf{S}_i . These ions also give rise to localized s or p states in the vicinity of the valence or conduction bands. Such a situation takes place for instance in GaMnAs,² where the acceptor level associated with a Mn impurity is formed near the top of the valence band. To have exchange interaction between two localized spins, the spin polarization of a localized state, induced by one magnetic impurity, should be transmitted to the place where the second magnetic impurity is located. When these impurities, say indexed by i and j , are not too far from each other, the wavefunctions of the corresponding localized donor (acceptor) states, ψ_i and ψ_j , overlap. In that case, the direct hopping between these localized states becomes important. In fact, it is crucial for the indirect exchange interaction proposed in this paper. Therefore, we must take it into account in the following considerations. If we assume for simplicity, that the impurity states are of s type, the corresponding term in the Hamiltonian may be written as

$$H_{hop} = \sum_{ij} \left(t_{ij} \psi_i^{\dagger} \psi_j + H.c. \right), \quad (2)$$

where t_{ij} denotes the hopping integral between states ψ_i and ψ_j . When the distance between impurities, $R = |\mathbf{R}_i - \mathbf{R}_j|$, is larger than the characteristic size r_0 of the localized wavefunction, one can assume t_{ij} in the exponential form, $t_{ij} = A \exp(-R/r_0)$. For s -type donor (acceptor) states with the activation energy ε_d , one can estimate the parameters A and r_0 as $A \simeq \varepsilon_d$ and $r_0 \simeq \hbar/(2m\varepsilon_d)^{1/2}$.

The total Hamiltonian of the system may be then written as $H = H_{eff} + H_{hop}$. This is the basic Hamiltonian which includes all the necessary interactions to describe the spin-spin coupling. The exchange interaction between two spins, \mathbf{S}_i and \mathbf{S}_j , can be calculated by the perturbation method, using Eq. (2) and the third term in Eq. (1) as small perturbations. The corresponding diagram for the coupling energy is presented in Fig. 1, where the solid line represents the Green function of band electrons, whereas the dashed lines correspond to the Green functions of the s -type states localized at the points i and j . There is also another contribution which corresponds to the diagram similar to that presented in Fig. 1, but with reversed orientation of the arrows. The corresponding analytical expression for the interaction energy (including contributions from both diagrams) has the form

$$E_{int}(\mathbf{R}_i, \mathbf{R}_j) = w_{\alpha\beta}(\mathbf{R}_i, \mathbf{R}_j) S_{i\alpha} S_{j\beta}, \quad (3)$$

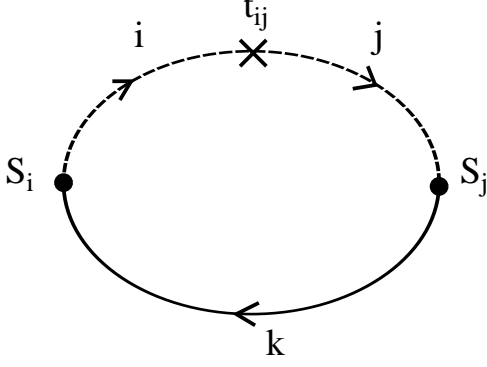

FIG. 1. Diagram contributing to the indirect exchange interaction.

where

$$w_{\alpha\beta}(\mathbf{R}_i, \mathbf{R}_j) = -\frac{ig^2 t_{ij}}{n} \times \text{Tr} \int \frac{d\varepsilon}{2\pi} [\sigma_\alpha G_i(\varepsilon) G_j(\varepsilon) \sigma_\beta G(\varepsilon; \mathbf{R}_j, \mathbf{R}_i) + \sigma_\alpha G(\varepsilon; \mathbf{R}_i, \mathbf{R}_j) \sigma_\beta G_j(\varepsilon) G_i(\varepsilon)]. \quad (4)$$

Here, $n = N/\Omega$ is the density of host atoms (with Ω denoting the crystal volume), whereas $G(\varepsilon; \mathbf{R}_i, \mathbf{R}_j)$ and $G_i(\varepsilon)$ are the Green functions of the band and localized electrons, respectively. For simplicity, the effective hybridization parameters $g_{\mathbf{k}}$ are taken constant, $g_{\mathbf{k}} = g$. In the case of a simple parabolic band, $\varepsilon_{\mathbf{k}} = \hbar^2 k^2 / 2m$, the corresponding Green functions take the form

$$G(\varepsilon; \mathbf{R}_i, \mathbf{R}_j) = \int \frac{d^3\mathbf{k}}{(2\pi)^3} \frac{\exp[i\mathbf{k} \cdot (\mathbf{R}_i - \mathbf{R}_j)]}{\varepsilon - \varepsilon_{\mathbf{k}} + i\delta \text{sgn}(\varepsilon - \mu)} = -\frac{m \exp(i|\mathbf{R}_i - \mathbf{R}_j| \kappa)}{2\pi\hbar^2 |\mathbf{R}_i - \mathbf{R}_j| \kappa}. \quad (5)$$

On the other hand, for the localized states $\varepsilon_i = \varepsilon_j = \varepsilon_0$ one finds

$$G_i(\varepsilon) = [\varepsilon - \varepsilon_0 + i\delta \text{sgn}(\varepsilon - \mu)]^{-1}. \quad (6)$$

In the above equations μ stands for the chemical potential and κ is defined as $\kappa = (2m\varepsilon)^{1/2}/\hbar$. The integration over ε in Eq. (4) is to be carried out along the real axis with an infinitesimally small shift ($-i\delta$) into the negative imaginary part of the complex plane for $\varepsilon < \mu$, and with a small shift ($i\delta$) into the positive imaginary part of the complex plane for $\varepsilon > \mu$.

Let us consider now in more details the case of $\varepsilon_0 < 0$ and $\varepsilon_0 < \mu < 0$. This situation corresponds to the localized donor level ($\varepsilon_d = -\varepsilon_0$) filled with electron, and an empty conduction band at $T = 0$. In the limit $T \rightarrow 0$, the chemical potential μ can be taken near the bottom of the conduction band, $\mu = 0^-$. Using Eqs. (4) to (6), we can calculate the integral over ε by closing the integration

path in the upper half-plane of the complex variable ε like presented in Fig. 2, where the thick line shows the cut in the complex plane related to $\sqrt{\varepsilon}$. Only the second-order pole at $\varepsilon = \varepsilon_0$ contributes to the integral. After calculating Eq. (4), we arrive at the following expression for the coupling energy:

$$w_{\alpha\beta}(R) = -\delta_{\alpha\beta} \frac{2g^2 t_{ij} m^2}{\pi\hbar^4 \kappa_0 n} e^{-R\kappa_0}, \quad (7)$$

where $R = |\mathbf{R}_i - \mathbf{R}_j|$ and $\kappa_0 = (2m|\varepsilon_0|)^{1/2}/\hbar$.

The indirect exchange coupling described by Eq. (7) originates from the magnetic polarization of the lattice via the impurity states and is ferromagnetic in sign. Contrary to the RKKY coupling, the interaction described by Eqs. (3) and (7) does not depend on the free carrier concentration, and therefore may exist even in non-degenerate semiconductors at $T = 0$.

Taking the approximate formula for t_{ij} , as described after Eq. (2) and valid in the case when the distance between impurities is larger than the characteristic size of the localized wavefunctions, we obtain the interaction range function in the form

$$w_{\alpha\beta}(R) \simeq -\delta_{\alpha\beta} \frac{2g^2 |\varepsilon_0| m^2}{\pi\hbar^4 \kappa_0 n} e^{-2R\kappa_0}. \quad (8)$$

Let us estimate now magnitude of the interaction. For $R\kappa_0 \simeq 1$ we obtain $|E_{int}| \sim (g/|\varepsilon_0|)^2 |\varepsilon_0|$. Thus, one can expect maximum of the interaction at $|g/\varepsilon_0| \sim 1$, when $|E_{int}|_{max} \sim |\varepsilon_0|$. For $|g/\varepsilon_0| \simeq 0.3$ and for $|\varepsilon_0| \simeq 100$ meV, we get $|E_{int}| \simeq 100$ K.

The above calculation of the exchange interaction (Eqs. 7 and 8) applies to the situation, where the donor level is below the conduction band. The calculation is also valid when the acceptor level is located above the valence band, simply by replacing electrons with holes.

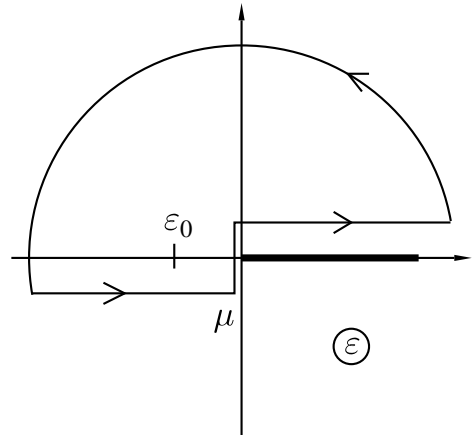

FIG. 2. Path of the integration in Eq. (4).

However, the structure of the valence bands in zinc-blende semiconductors is more complex and cannot be described by a simple parabolic model. The proposed mechanism, however, is still valid in this case, but the interaction should have a form which is more complex than that described by Eq. (7).

If an acceptor level forms a resonance in the valence band, the mechanism presented in this letter is working as well, provided the Fermi level lies between the level ε_0 and the top of valence band. In that case the acceptor level behaves like a pseudo-donor, and the virtual transitions of electrons between the level and the valence band are responsible for the spin-spin coupling. However, the usual RKKY interaction *via* free holes can dominate the exchange spin-spin interaction in this case.

It should be mentioned at this point, that the ferromagnetism induced by resonance impurity-band mixing in degenerate semiconductors has been considered long time ago by Abrikosov.¹³ Magnetic moments and ferromagnetism appear then, when the impurity level is situated close to the Fermi energy. Contrary to this model, in our case the magnetic moments (\mathbf{S}_i) are formed by deep *d*-states of the impurities, and their mixing to the band states *via* direct exchange coupling gives rise to indirect exchange interaction between localized spins, and consequently to ferromagnetism.

In conclusion, we proposed in this Letter a new mechanism of exchange interaction of magnetic impurities in semiconductors. The mechanism takes into account the fact that the *d*-shell spin \mathbf{S}_i is located at the same point as the shallow localized impurity state ψ_i (donor or acceptor). The main point of the mechanism is the interplay of the direct exchange interaction of the band states and localized spins, and the hybridization of the band states with the localized donor or acceptor states. The information on the spin state of the impurity is then transmitted from one impurity to the other owing to the overlap of the corresponding wavefunctions of the localized states.

The mechanism favors ferromagnetic ordering of the impurity spins and the coupling energy is independent of the free carrier density. Therefore, this mechanism may play an important (or even crucial) role at low carrier concentrations, and may be responsible for the ferromagnetism observed in such systems like for instance GaMnAs alloy semiconductors.

V.D. thanks V. R. Vieira and P. D. Sacramento

for comments. This work is partially supported by the Polish State Committee for Scientific Research through the Project No. 5 03B 091 20, NATO Linkage Grant No. 977615, and NATO Science fellowship CP(UN)06/B/2001/PO.

[†] E-mail: vdugaev@deetc.isel.ipl.pt

- ¹ G. A. Prinz, *Science* **282**, 1660 (1998); S. A. Wolf, D. D. Awschalom, R. A. Buhrman, J. M. Daughton, S. von Molnár, M. L. Roukes, A. Y. Chtchelkanova, and D. M. Treger, *Science* **294**, 1488 (2001).
- ² F. Matsukura, H. Ohno, A. Shen, and Y. Sugawara, *Phys. Rev. B* **57**, R2037 (1998); H. Ohno and F. Matsukura, *Sol. State Communs.* **117**, 179 (2001).
- ³ B. Beschoten, P. A. Crowell, I. Malajovich, D. D. Awschalom, F. Matsukura, A. Shen, and H. Ohno, *Phys. Rev. Lett.* **83**, 3073 (1999).
- ⁴ T. Dietl, *cond-mat/0201282* (2002).
- ⁵ J. König, J. Schliemann, T. Jungwirth, and A. H. MacDonald, *cond-mat/0111314* (2001).
- ⁶ T. Dietl, H. Ohno, F. Matsukura, J. Cibert, and D. Ferrand, *Science* **287**, 1019 (2000); T. Dietl, H. Ohno, and F. Matsukura, *Phys. Rev. B* **63**, 195205 (2001).
- ⁷ B. Lee, T. Jungwirth, and A. H. MacDonald, *Phys. Rev. B* **61**, 15606 (2000); J. König, H.-H. Lin, and A. H. MacDonald, *Phys. Rev. Lett.* **84**, 5628 (2000).
- ⁸ M. A. Ruderman and C. Kittel, *Phys. Rev.* **96**, 99 (1954); T. Kasuya, *Prog. Theor. Phys.* **16**, 45 (1956); K. Yosida, *Phys. Rev.* **106**, 893 (1957).
- ⁹ J. Inoue, S. Nonoyama, and H. Itoh, *Phys. Rev. Lett.* **85**, 4610 (2000).
- ¹⁰ V. I. Litvinov and V. K. Dugaev, *Phys. Rev. Lett.* **86**, 5593 (2001).
- ¹¹ N. Bloembergen and T. Rowland, *Phys. Rev.* **97**, 1679 (1955).
- ¹² M. Berciu and R. N. Bhatt, *Phys. Rev. Lett.* **87**, 107203 (2001); M. Berciu and R. N. Bhatt, *cond-mat/0111045* (2001); R. N. Bhatt, M. Berciu, M. P. Kennett, and X. Wan, *cond-mat/0111184* (2001).
- ¹³ A. A. Abrikosov, *Zh. Eksp. Teor. Fiz.* **65**, 814 (1973).