

# Optical Intensity Interferometry with Atmospheric Cherenkov Telescope Arrays

S. Le Bohec

*Department of Physics, University of Utah, Salt-Lake-City, UT, 84112-0830, USA*

lebohec@physics.utah.edu

and

J. Holder

*School of Physics and Astronomy, University of Leeds, Woodhouse Lane, Leeds, LS2 9JT, UK*

jh@ast.leeds.ac.uk

## ABSTRACT

In the 1970s, the Narrabri intensity interferometer was used to measure 32 stellar diameters; some as small as 0.4 milli-arc-seconds (mas). The interferometer consisted of a pair of 6.5 m telescopes ( $30\text{ m}^2$ ) with relatively crude optics, similar to those currently in use as Atmospheric Cherenkov Telescopes (ACT). We explore the possibility of implementing a modern intensity interferometer on an ACT array. Developments in fast digital signal processing technology now make such a system relatively easy to implement, and provide improved sensitivity. Allowing measurements at short wavelength ( $< 400\text{ nm}$ ), with long baselines ( $> 100\text{ m}$ ), which are still challenging for Michelson interferometers, present ACT arrays could be used to probe angular structures as small as  $\sim 0.2\text{ mas}$ , and smaller with large array projects already being discussed. This would provide measurements of stellar diameters, binary systems, circumstellar environments and, possibly, stellar surface features. ACT arrays could be used as intensity interferometers during bright moon periods, providing valuable scientific output for little expense and no impact on the  $\gamma$ -ray observing schedule.

*Subject headings:* intensity interferometry, Atmospheric Cherenkov Telescope arrays, stellar diameters, binaries

## 1. Introduction

The first successful measurement of the angular diameter of a star was made using the Michelson optical interferometer on Mount Wilson, over a baseline of 20 feet, (Michelson 1920; Michelson & Pease 1921). Difficulties encountered in the subsequent operation of a 50 foot baseline interferometer brought the development of stellar interferometry to a halt for thirty years. No further progress was made until the sixties, with the construction and operation of the Narrabri intensity interferometer.

Intensity interferometry was originally developed in the early fifties in the field of radio astronomy by R. Hanbury Brown, who soon extended the idea to the optical domain. After several laboratory tests and actual stellar intensity interferometer prototypes, the technique culminated in the 60s with the interferometer constructed under the direction of Hanbury Brown and Twiss in Narrabri. The Narrabri intensity interferometer was successfully used to study 32 stars (Brown et al. 1974), all brighter than  $B=+2.5$ , providing angular diameter measurements as small as  $0.41 \pm 0.03$  milli-arc-seconds (mas). Despite these successes, and plans for a larger instrument, the technique was then abandoned to the benefit of Michelson interferometry, which had become attractive again because of technological developments in photo-detection and optics. Since then, to our knowledge, intensity interferometry has not been used for astronomical measurements.

In this paper, we revisit intensity interferometry and the scientific potential it could offer if implemented on large Atmospheric Cherenkov Telescopes using modern signal processing technology. In section 2, we briefly review the principles of intensity interferometry. In section 3, we describe how an intensity interferometer could be implemented with an ACT array and in the two following sections, we comment on some specific points regarding the telescope's optics and the electronics. In the last section, we conclude and comment on the possible future developments and scientific potentials of intensity interferometry.

## 2. Principles of intensity interferometry

### 2.1. Intensity interferometry

Ideas in this section are for the greatest part taken from the excellent monograph by R. Hanbury Brown (Brown 1974) in which he describes the theory of intensity interferometry and the technical aspects of the construction and operation of the Narrabri interferometer. Intensity interferometry is rather counter-intuitive when applied to the optical domain, and the idea was first received with controversy until several experimental tests confirmed the

technique was well-founded. Today it is even applied to  $\pi_0$ 's emerging from nuclear collisions (Boal et al. 1990), for synchrotron X-ray beam diagnostics (Yang 1994; Tai 2000) and in other fields.

In a stellar intensity interferometer, the light from a star is received by two separated photoelectric detectors through a narrow optical bandwidth filter. Intensity interferometry relies on the fact that the fluctuations in the current output by the two detectors ( $\Delta i_1$  and  $\Delta i_2$ ) are partially correlated. The principal component of the fluctuation is the classical shot noise which does not show any correlation between the two detectors. In addition, there is a smaller component, the wave noise, which can be seen as the beating between the different Fourier components of the light reaching the detectors. The wave noise shows correlation between the two detectors provided there is some degree of coherence between the light at the two detectors. The important point here is that the correlation is a function of the difference in phase between the low frequency beats at the two detectors. This correlation does not depend on the phase difference of the light at the two detectors. The requirements on the mechanics and optics of an intensity interferometer are therefore much less stringent than in the case of a Michelson interferometer. Because of this correlation, the time integrated product of the current fluctuations  $\Delta i_1$  and  $\Delta i_2$  is positive and provides a measurement of the square of the degree of coherence  $\gamma_d$  of the light at the two detectors.

Figure 1 is a functional schematic of an intensity interferometer. It can be shown that  $\langle \Delta i_1(t) \Delta i_2(t) \rangle / (\langle i_1 \rangle \langle i_2 \rangle) = |\gamma_d|^2$ . The degree of coherence is equivalent to the fringe visibility measured with a Michelson interferometer. In the case of a star modeled as a uniform disk, it depends upon the star's angular diameter  $\theta$ , the wavelength,  $\lambda$ , and the distance between the two detectors,  $d$ , reaching zero when  $d = 1.22\lambda/\theta$ . More generally, according to the van Citter-Zernike theorem,  $\gamma_d$ , the complex degree of coherence, is the normalized Fourier transform of the source intensity distribution projected on a line parallel to the line joining the two detectors. Figure 2 shows the squared degree of coherence as a function of the base-line as it would be measured by an ideal intensity interferometer observing uniform-disk shaped stars of different angular diameters. Baselines available in existing ACT arrays would permit to probe the stellar diameter range from  $\sim 0.1$  mas to  $\sim 1$  mas. A 1 km baseline, as might be offered by the next generation of ACT arrays, would make possible the measurement of stellar diameters smaller than  $50 \mu\text{as}$ .

## 2.2. Noise considerations

The shot noise from both channels is responsible for most of the multiplier output fluctuations to which the wave noise correlation has to be compared for the sensitivity of a

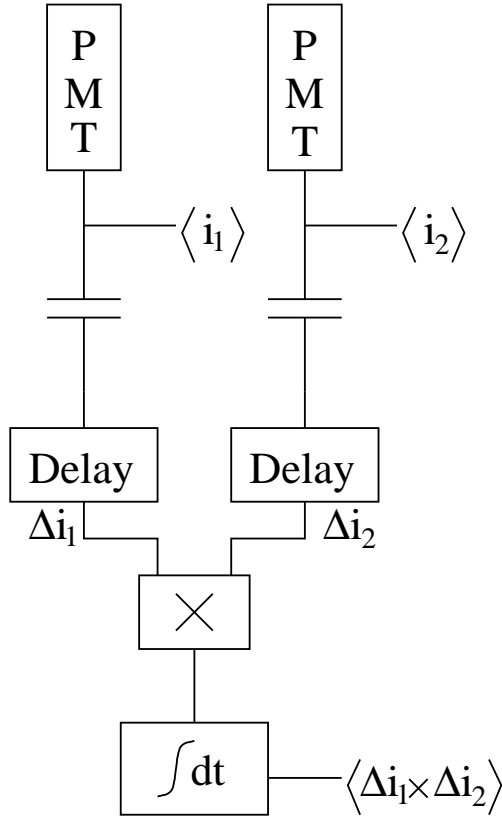

Fig. 1.— In each receiver, a photo-multiplier tube is used to measure the star light intensity. The DC components  $\langle i_1 \rangle$  and  $\langle i_2 \rangle$  of both signals are measured. The AC components  $\Delta i_1(t)$  and  $\Delta i_2(t)$  must be placed in time before being multiplied together in the correlator. This product is then integrated over time, providing a measurement of the degree of coherence at the two receivers.

specific experiment to be estimated. Hanbury Brown showed that the signal to noise ratio can be expressed by equation 1.

$$(S/N)_{\text{RMS}} = A\alpha n |\gamma_d|^2 (\Delta f T / 2)^{1/2} \quad (1)$$

where  $A$  is the collection area of each telescope,  $\alpha$  the photo-detector quantum efficiency,  $\Delta f$  the bandwidth of the electronics including the photo-detector,  $T$  the integration time and  $n$  the intensity of the source in photons per unit optical bandwidth, per unit area and per unit time. Using a pair of  $100 \text{ m}^2$  telescopes with 30% quantum efficiency photo-detectors, 1 GHz electronics during a full 5 hours night would permit to measure the diameter of stars with visual magnitude 6.7 with 5 standard deviations at  $|\gamma_d|^2 = 0.5$ . This would result in a measurement of the diameter with an accuracy of 14%. The diameter of a magnitude 5 star could be measured with an accuracy of 3% in the same amount of time.

### 2.3. Comparison with Michelson Interferometry

After decades of development, a number of world-class instruments for long-baseline optical interferometry are currently operating or soon to come online - for a review see (Monnier 2003). These are, without exception, based upon the Michelson technique for interferometry. The advantage of this method is clear. As it relies on the visibility of fringes produced by the amplitude interferences formed by the light collected by two telescopes, it permits to measure stars much dimmer than intensity interferometry with same size telescopes.

Michelson interferometry is also a very challenging technique as the relative length of the paths of light have to be controlled with an accuracy smaller than the wavelength of the light being measured. This requires high optical quality and high precision tracking. The situation is further complicated by the effects of atmospheric turbulence which have to be actively compensated for. These difficulties have constrained Michelson interferometry to smaller baselines (with the exception of CHARA (ten Brummelaar et al. 2005) all interferometers have maximal operational baselines of less than 100 m) and longer wavelengths ( most interferometers work in the near-IR and mid-IR) while the angular resolution is proportional to the baseline and to the inverse of the wavelength.

Intensity interferometry, however, only requires control of the path of light to an accuracy fixed by the bandwidth of the electronics. For a system with 1 GHz bandwidth, differences in the light paths of a few centimeters would affect the correlation level by less than 10%. It is also therefore essentially insensitive to atmospheric fluctuations and the use of shorter wavelengths does not result in any extra difficulty. Intensity interferometry also permits to simultaneously measure the degree of coherence between any two telescope pair of an array, while with Michelson interferometry this is impossible without a loss in sensitivity. A two-telescope based intensity interferometer does not provide the phase of the complex degree of coherence and an image can only be reconstructed up to a central symmetry. With a system consisting of three or more telescopes, however, the phase can be reconstructed (Ofir & Ribak 2006b; Gamo 1963). Intensity interferometry, as with Michelson interferometry, allows model-independent reconstruction of the object image. The major drawback associated with intensity interferometry is the demand for very large quantities of light. The necessary large light collectors do not, however, need to offer optical astronomy quality as they are only required to concentrate the light on a photo-detector. Furthermore, such light collectors are readily available in ACT arrays.

### 3. Possible Implementations

#### 3.1. The Narrabri interferometer

We begin this section with a brief description of the Narrabri intensity interferometer, in order to have an experiment of measured sensitivity with which to compare.

The Narrabri interferometer consisted of two telescopes, each 6.5 m in diameter, with an 11 m focal length. The telescopes were carried on trucks running on a circular railway track 188 m in diameter. This allowed the interferometer to operate with a baseline of 10 m to 188 m, and to track any star while keeping the line joining the two telescopes perpendicular to the direction of the star. Having movable telescopes removes the need for additional delay lines to bring the signals in time. At the focus of each telescope, the converging light was collimated and passed through an interference filter centered on 443 nm with a passing band width of 10 nm. The light was then focused onto a photomultiplier tube which converted the light intensity to a current with 25% quantum efficiency at 440 nm and a 60 MHz effective bandwidth. The signals were sent to the control building where the correlator was located.

The DC component of the signals was measured and recorded while the AC components were sent to the input of the correlator, a 4 transistor based linear multiplier. The DC component to be measured on the output of the multiplier is very small in comparison to the random fluctuations ( $\sim 100$  dB). This difficulty was resolved by integrating the output of the multiplier over 100 s time intervals. The drifting effects of small offsets that would have drowned the signal also had to be eliminated. This was achieved by applying the technique of phase-switching, which consisted of inverting the phase of the signals on the input of the multiplier at rates of 10 kHz and 10 Hz respectively. On the output of the multiplier, these switching frequencies were amplified and demodulated before the signal was integrated, thus removing any significant contamination due to offsets. This clearly was the critical part of the experiment and great efforts had to be made in order to reduce spurious correlations to acceptable levels. For an unresolved ( $\gamma_d = 0$ ) 0 visual magnitude star observed during one hour, the predicted signal to noise ratio amounts to  $\sim 130$ . The actual signal to noise ratio was degraded by a factor 5 because of optical losses and excess noise of various origins. This limited observations to stars brighter than  $B = +2.5$ .

Hanbury Brown and Twiss proposed several possible improvements to attain higher sensitivities. Aside from increasing the telescope size and improving the electronics bandwidth, they proposed to multiply the number of independent optical channels used in the measurements. The sensitivity does not depend on the optical band-width, and so this can be easily achieved by simultaneously using several narrow optical bands. Sensitivity improvements can also result from observing the same star with an array of telescopes providing

measurements over several baselines simultaneously (Herrero 1971). In a  $N$  telescope array, the number of baselines is  $\frac{N(N-1)}{2}$ . These ideas could be combined with the technological developments during the last 30 years which have provided higher bandwidth photo-detectors and electronics and the possibility of processing digitized signals at high speed.

### 3.2. Ground-based $\gamma$ -ray telescopes and intensity interferometry

The two telescopes of the Narrabri interferometer were also used in a search for astronomical sources of very high energy ( $E > 300\text{GeV}$ )  $\gamma$ -rays (Grindlay et al. 1975A; Grindlay et al. 1975B). Cosmic rays and  $\gamma$  rays reaching the Earth’s atmosphere trigger extensive particle showers which produce Cherenkov light. This light can be detected with large telescopes equipped with fast photo-detectors and electronics. Since these early measurements, the field of ground based  $\gamma$ -ray astronomy has matured and more than 30 very high energy  $\gamma$  ray emitters are now known (Aharonian 2005). This success can be entirely attributed to the sensitivity achieved with imaging atmospheric Cherenkov telescopes (Weekes 2003) used in stereoscopic arrays. Existing major ground based  $\gamma$ -ray observatories like CANGAROO (Kubo et al. 2004), H.E.S.S. (Bernlöhner et al. 2003), MAGIC (Lorenz 2004) and VERITAS (Krennrich et al. 2003) consist of arrays of ACTs which satisfy many of the specifications for a productive intensity interferometer. We summarize the main characteristics of existing and projected ACT arrays and their corresponding capabilities as intensity interferometers in Table 1. Existing ACT arrays typically extend over 200 m, making them comparable to the Narrabri interferometer from the point of view of the angular resolution they could achieve. Telescopes have diameters ranging from 10 m to 17 m providing a gain of 2.8 to 8.0 in sensitivity (0.94 to 2.1 magnitude) when compared to the Narrabri interferometer. Furthermore, these arrays (except for MAGIC) consist of 4 telescopes, and could permit measurements along up to six baselines simultaneously. This corresponds to a sensitivity gain of  $\sim 2.5$ , or one magnitude. Table 1 also provide estimates of the sensitivity that could be achieved with these arrays. Sensitivity estimates resulting from equation 1 are probably optimistic as some loss is unavoidable. On the other hand, the simple scaling from the Narrabri performances does not account for the further sensitivity improvement that must result from the tremendous progress in signal processing electronics since the 60s. Furthermore, Ofir and Ribak (Ofir & Ribak 2006a) have recently shown that with a many telescope array, by using higher order correlation, it might be possible to more than double the signal to noise ratio and therefore improve sensitivity by almost one magnitude. Even without considering this, the table clearly indicates the high potential offered by ACT arrays in the domain of stellar interferometry: it shows the possibility of baselines to wavelength ratios never attained before with sensitivity comparable to modern Michelson interferometers.

Array	N	A	n	$d_{\min} - d_{\max}$	$\theta_{\min} - \theta_{\max}$	$V_{Max}$	$T_{V=5}$
MAGIC-II	2	227	1	85	1.2	4.7 (6.0)	0.16
CANGAROO	4	57	6	100 to 184	0.5 to 1.0	4.2 (5.5)	2.61
HESS-4	4	108	6	120 to 170	0.6 to 0.8	4.9 (6.1)	0.73
VERITAS-4	4	113	6	80 to 140	0.7 to 1.2	4.9 (6.2)	0.66
VERITAS-7(*)	7	113	21	80 to 160	0.6 to 1.2	5.6 (6.9)	0.66
HESS-16(*)	16	108	120	120 to 510	0.2 to 0.8	6.5 (7.8)	0.73
Next-Generation (**)	50	100	1225	80 to 1000	0.1 to 1.2	7.7 (9.0)	0.85
Narrabri	2	30	1	10m $\rightarrow$ 188m	0.5 to 10	2.5 (3.8)	9.4

Table 1: N represents the number of telescopes, A is the light collection area of each telescope in  $\text{m}^2$  (all of these arrays consist of identical telescopes), n is the number of baselines simultaneously available,  $d_{\min} - d_{\max}$  indicates the range of baselines in meters for observation at zenith. The corresponding range of angular diameters in mas ( $1.22\lambda/d$ ) for observations at 400 nm is indicated by  $\theta_{\min} - \theta_{\max}$ .  $V_{Max}$ , is the largest stellar magnitude that could be attained with such an array. The first number was obtained simply by scaling the largest magnitude measured with the Narrabri interferometer by the increase in light collection area. The number between brackets was obtained by applying equation 1 with a quantum efficiency of 25%, a bandwidth of 100 MHz, and an observing time of 1 hour to detect the non-resolved correlation ( $|\gamma_d|^2 = 1$ ) with 5 standard deviations. Both numbers are scaled to account for the number of simultaneously available baselines under the assumption that the star is not resolved even with the largest baseline.  $T_{V=5}$  (in hours) is the time required to reach a five standard deviation detection of the correlation of an unresolved  $5^{th}$  magnitude star with one pair of telescopes. For an actual measurement across one baseline, one must achieve a sensitivity corresponding to  $|\gamma_d|^2 \approx 0.5$  and this time has to be at least quadrupled. (\*) These original proposals for HESS and VERITAS are not yet being deployed, all others are in operation or under construction. (\*\*) “Next-Generation” does not correspond to any specific project or experiment but provides an indication of the major parameters of possible future large arrays currently being studied.



Converting an ACT telescope into an intensity interferometer element seems quite simple and inexpensive. A plate is mounted in front of the camera, protecting the photomultipliers used for  $\gamma$ -ray observations and serving as an optical bench for the interferometer elements. A mirror at a  $45^\circ$  angle from the telescope axis is used to redirect the light towards a lens used as a collimator. After passing through a narrow bandwidth filter, the light can be concentrated on a photodetector as shown schematically in Figure 3.

At this point we have shown that the idea of using ACT arrays as intensity interferometer seems promising and does not encounter any obvious practical problems. ACT arrays have scientific programs which are incompatible with interferometry observations. However, in practice, ACTs are only used for  $\gamma$ -ray observation during Moonless nights. Stray light from the Moon should only slightly reduce the sensitivity of an intensity interferometer and telescope time allocation could be set according to the Moon visibility, leaving almost half the night time available for interferometry measurements. In the next section we discuss specifics and practical issues related to details of the implementation of an intensity interferometer using ACT arrays.

## 4. Optics

### 4.1. Limitations due to the specific optical design of many ACTs

Atmospheric Cherenkov telescopes are designed with an angular resolution optimized for Cherenkov images over the widest fields of view possible, with aperture ratios close to unity. The solution adopted by HESS and VERITAS was to use the Davies-Cotton design (Davies and Cotton 1957), which does not preserve isochrony. For 12m telescopes with aperture ratio close to one, this results in an effective bandwidth limitation close to 100 MHz. With these telescopes, it is therefore not possible to improve sensitivity over the Narrabri intensity interferometer by utilizing the larger bandwidths nowadays available. The MAGIC and CANGAROO telescopes have parabolic mirrors which do not cause any time dispersion. For these telescopes, it would be possible to use much higher bandwidth, probably up to 1 GHz, which would result in a sensitivity improvement of 1.25 magnitudes which was not included in table 1.

### 4.2. Consequences of the fixed positions of telescopes in ACT arrays

At Narrabri, the two telescopes could be moved along tracks to keep the signals in time and maintain a fixed baseline as the star was tracked for long periods of time. In ACT

arrays, telescopes are at fixed locations. This has three consequences complicating the use of these telescopes in an intensity interferometer.

First, the signals from different telescopes have to be brought back in time for the correlation to be measured. Programmable delays can be used to accomplish this; an analog delay system with similar requirements has been operated by the CELESTE experiment (Pare 2002). It should be noted that the accuracy necessary for the timing corrections is fixed by the system bandwidth. For the contribution from the highest frequency preserved by the system to be degraded by less than 10%, the timing must be controlled with an accuracy better than 7% of the corresponding period. For example, a  $\sim 100$  MHz system requires timing corrections to within  $\sim 0.7$  ns.

Second, the length and orientation of the effective baseline between two telescopes depends on the position of the star in the sky. Stars with diameters several times larger than the  $1.22\lambda/d$  indicated in table 1 could effectively be measured by making observations at lower elevation where baselines are effectively reduced. The baseline will also change with time during the observation of any star. This can be taken into account at analysis time provided that intermediate results are stored regularly. This turns out to be useful as a continuous range of effective baselines can be probed in one night, even with a single pair of receivers. This is already used in radio and optical interferometry (2).

Third, in ACT arrays, there are no close pairs of telescopes with which we could obtain close to zero baseline measurements. The optimal distance between telescopes is set for  $\gamma$ -ray observations by the radial extension of the Cherenkov light pool produced by atmospheric high energy showers, which is in excess of 120 m. As a consequence, telescopes would not be placed at much less than 80 m from each other. Zero baseline interferometer measurements are, however, desirable. It is in fact possible to obtain a zero baseline measurement from single telescopes. This can be done by splitting the beam of collimated and filtered light. The correlation of the fluctuations in the two beams from one telescope then provides a zero baseline measurement of the coherence. Each telescope could be used for zero baseline measurements and still be used in other baselines.

### 4.3. Noise limitations associated with the field of view

Cherenkov images of atmospheric showers of interest to very high energy  $\gamma$ -ray astronomy are elongated with typical lengths of half a degree and widths of a few tenths of a degree. The width of these images sets the ACT pixel size to  $0.1^\circ - 0.2^\circ$  and the optical system is typically designed to produce a point spread function matching the pixel size. Sensitivity

estimates presented above were made assuming that the only noise was due to the Poisson fluctuations in the light from the star being measured. The finite size of the point-spread function makes it impossible to avoid also having some amount of night sky background (NSB) light polluting the star light. The NSB light collected by two telescopes does not produce any correlation signal, but by increasing the shot noise it limits the sensitivity that can be attained in a given observation time. If  $\sim 30\%$  of the collected light is not coming from the star, the time necessary to attain a given significance for the measurement of the correlation is increased by a factor two. The continuum spectral density from a star of visual magnitude  $V$  is approximately  $5 \times 10^{-5} \text{ m}^{-2} \text{ s}^{-1} \text{ Hz}^{-1} 2.5^{-V}$  while from the NSB it is close to  $5 \times 10^{-3} \text{ m}^{-2} \text{ s}^{-1} \text{ Hz}^{-1} \text{ sr}^{-1}$  (Celik 2005). From this, we see that with a typical point spread function of  $0.05^\circ$  ( $\sim 6 \times 10^{-7} \text{ sr}$ ) as in MAGIC, HESS or VERITAS, stars of magnitude 9.6 are the dimmest that could practically be measured. If it were not for this limitation, solar arrays used for atmospheric Cherenkov  $\gamma$ -ray observation, such as STACEE (Hanna 2002), would be extremely attractive, providing several hundred receivers each with a  $37 \text{ m}^2$  light collecting area (this solution was recently proposed by Ofir & Ribak 2006b). However, the point spread function of these mirrors typically extends over close to half a degree, severely limiting the sensitivity that could be achieved if the array were used as an interferometer.

## 5. Electronics

### 5.1. The photo-detectors

Since the seventies, developments in photo-detection have been dramatic. The two most important aspects for us to consider are bandwidth and quantum efficiency. Some modern photomultiplier tubes have bandwidths of more than 1 GHz. As already mentioned, in comparison to the 60 MHz bandwidth used in Narrabri, this corresponds to a sensitivity gain of more than one magnitude provided the optical system has a compatible bandwidth. As for the quantum efficiency, solid state photo-detectors seem attractive with quantum efficiencies of more than 70%. Unfortunately, for large enough photodiodes, the bandwidth is not as good as can be found in photomultipliers and, more importantly, noise prevents them from having the sensitivity required for stellar intensity interferometry. Photomultipliers with GaASP photocathode, however, have quantum efficiency curves peaking close to 50%, which corresponds to a gain of more than half a magnitude if compared to the 25% quantum efficiency in the Narrabri interferometer. Combining improvements in bandwidth and quantum efficiency since the 70s, the observation time required to reach a given sensitivity can be halved.

## 5.2. Cable bandwidth and large baselines

Analog signals could be brought to a central location and then correlated using analog or digital techniques. In this approach the bandwidth of the signal transmission over several hundreds of meters is critical. Even broadband cable such as RG-6 gives more than 4 dB attenuation over 100 m at 50 MHz. Analog signal transmission bandwidth can effectively limit the sensitivity of telescopes such as MAGIC or CANGAROO which, in principle, have the capability of working with larger bandwidth. A possibility for circumventing this problem is to use analog optical fiber transmission. This is already being used in the MAGIC system for  $\gamma$ -ray observation and the MAGIC collaboration has demonstrated the possibility of transmitting analog signals with attenuations of 3 dB/Km at 500 MHz with a dynamic range of 62 dB (Paneque et al. 2003). Such a dynamic range is sufficient to allow for the measurements over a range of more than 10 magnitudes without changing gains, and in practice does not constitute a limitation.

Alternatively, it is possible to digitize the signals locally at each receiver and have the digitized signals sent to a central station where they can be combined to provide a measurement of their correlation. One difficulty of this approach resides in synchronizing the two digitizers. The difficulty of achieving synchronization of the digitizer depends on the digitization rate. This approach presents the advantage of eliminating all risk of noise contamination and signal attenuation in cables between the photodetectors and the correlator.

## 5.3. The correlator

The correlator must integrate over time the product of the AC components of two signals. The DC components must also be measured in order to normalize the correlation. Modern electronics make these tasks easier than it was in the 60s. Again, two approaches are now possible: analog and digital.

Signals could be sent through analog delays and, after proper amplification, be collected by a double-balanced mixer, a component used in a variety of radiofrequency applications which, in effect, forms the product of its two analog inputs. The mixer output is received by a voltage integrator. This method was successfully used in the intensity interferometer designed for synchrotron X-ray beam diagnostics by Yang et al. (1994). The drift of signals away from the zero point, which produces a false correlation, could be removed using the same phase-switching technique originally used by Hanbury Brown and Twiss. Nowadays this could also be achieved by using a lock-in amplifier as described in Tai et al. (2000). We are working on a table-top experiment (Figure 4) using this method.

The digital approach may follow two different paths. It is possible to, at least temporarily, store the digital data from each telescope and run an offline analysis to obtain the various correlations needed. The difficulty is the volume of data that has to be stored and manipulated (more than 200 Mb per telescope and per second for a 100 MHz bandwidth system). Alternatively, the digitized signals, once in a central location could be duplicated an indefinite number of times and sent to correlators implemented in Field Programmable Gate Arrays (FPGA). These could be programmed to bring the signals in time up to the digitization period before they are multiplied. This does however not eliminate the need for short analog delays. As we have seen, timing should be adjusted with an accuracy of a fraction of the period of the highest frequency which, in a digital system, could be assimilated to the Niquist frequency. The unavoidable offsets from the digitization would be responsible for drifting that would drown the correlation signal. This can be eliminated by phase switching. Figure 5 is a functional diagram presenting a possible implementation for a two channel system. The great advantage of a digital system implemented in an FPGA is that the algorithm can be modified at will. For example it could be adjusted to filter-out noise and reduce spurious correlations. We are starting to develop such a digital correlator which will be tested on the table-top experiment described in Figure 4.

## 6. Conclusions

We have previously presented the possibility of implementing an intensity interferometer using atmospheric Cherenkov telescope arrays (LeBohec & Holder 2005a; LeBohec & Holder 2005b). Here, we have shown that existing atmospheric Cherenkov telescopes could be used as the receivers of intensity interferometers to study stars of magnitude as large as 5 without taking advantage of the technological developments since the time of the Narrabri interferometer. Higher sensitivities are achievable with the faster and more stable electronics available today. These improvements, however, will not affect the sensitivity limit arising from the quality of the receiver optics. We have seen that existing ACTs, with a point spread function of  $\sim 0.05^\circ$  are restricted to objects of magnitudes smaller than  $\sim 9.6$  with a  $\sim 5$  hour integration. The optical requirements for interferometric studies could be taken into account in the design of future arrays of larger Cherenkov telescopes to make them more effective.

We have considered the constraints and technical difficulties associated with such a project and proposed some possible technical solutions without finding major difficulties. We conclude that available telescope arrays can, in principle, be used for the interferometric study of stars at wavelengths shorter than 400 nm with baselines close to 200 m. This would give access to angles as small as  $\sim 0.1$  mas. Figure 2 shows that, for example, the HESS or

VERITAS baselines allow for measurements of the correlation curve for stars with angular sizes of  $\sim 0.5$  mas, corresponding to a star the same radius as the sun at a distance of  $\sim 20$  pc. Future Cherenkov telescope arrays being discussed extend over  $\sim 1$  km and could be used to measure angles ten times smaller. One should then question the importance and role intensity interferometry could play in the coming years.

We note that the measurements provided by the Narrabri intensity interferometer of 32 stars, in the spectral range O5f to F8 (Brown et al. 1974), are still relevant and competitive today (Kervalla et al. 2004) although the instrument ceased taking measurements as long ago as 1972. The most useful observations which could be made with a modern-day intensity interferometer are guided mainly by the unique strengths of the technique. The relative ease of long-baseline measurements allows for very high angular resolution. A further consideration is the ability to make measurements at shorter wavelengths than those usually probed by Michelson devices. Finally, long exposures using ground-based  $\gamma$ -ray telescopes under moonlight are effectively free of competition for observing time, allowing the possibility of very long-term monitoring of variable sources.

The scientific potential of optical interferometry in general is outlined in e.g. (Monnier 2003). Figure 6 illustrates the capabilities of a ground-based  $\gamma$ -ray telescope array at measuring stellar angular diameters. Knowledge of the angular diameter of stars is important for the understanding of their fundamental properties. Angular measurements are affected by the limb darkening in a way that depends on the wavelength (Mozurkewich et al. 2003). Intensity interferometers, with their capability of working over a range of short visible wavelengths, could contribute to the measurements of the stellar diameter wavelength dependence. The long base-lines offer the possibility of measuring main sequence late-type stars for which data is still missing (Kervalla et al. 2004). Measurements of Cepheid stars can be used to obtain improved calibration of the period-luminosity relation (Kervalla 2006). Arrays of more than two telescopes could also be used to measure the oblateness of rapid rotators, providing further parameter constraints on stellar evolution models (van Belle 2006). Future arrays with many base lines simultaneously available could even measure finer details on stellar surfaces as in (Young 2000). The observation of spectroscopic binaries is also of interest; resolving the components of these systems would determine all of the system parameters, including the respective members' masses (2). It is also simple, with an intensity interferometer, to select emission lines so as to study the circumstellar environment. The NPOI was used recently to study H  $\alpha$  emitting regions in Be stars  $\gamma$  Cassiopeiae and  $\phi$  Persei with base lines of 40 m and less. Using an ACT intensity interferometer with an H  $\beta$  emission line filter could possibly reveal details ten times smaller (Tycner 2006). Objects such as  $\zeta$ -Tauri stars (Tycner 2004), Wolf-Rayet stars, Luminous-Blue-Variables (Chesneau 2003) or even novae (Quirrenbach 1993) could also be monitored at short wavelength with unprecedented

interferometric baselines.

In summary, atmospheric Cherenkov telescope arrays provide an inexpensive and practical way by which to implement a modern intensity interferometer. The technical difficulties are few, and the successful operation of an intensity interferometer system on currently operating ACT arrays would significantly increase the scientific output of these instruments. The experience gained from operating such a system would also allow for direct input, relevant to interferometry measurements, into the design of next generation systems.

SLB acknowledges support from NSF grant #58500944 and University Of Utah Research Foundation. JH acknowledges support from PPARC. We are grateful to David Kieda, Jeremy Smith, Jeter Hall and the members of the VERITAS collaboration for many useful discussions. We would also like to thank Micah Kohutec for setting up the table-top test bench and Emmet Valfredini for his technical assistance.

## REFERENCES

- Aharonian, F. A., et al., 2005, *Science* 307, 1938-1942
- Barnes, T. G. & Evans, D. S., 1976, *MNRAS*, 174, 489
- Berndlöhr, K., et al., 2003, *Astroparticle Physics*, 20, 111-128
- Boal, D.H., et al., 1990, *Rev. Mod. Phys.* 62, 553-602
- Hanbury Brown, R.; Davis, J. and Allen, L. R., 1974, *MNRAS*, 167,121
- Hanbury Brown, R., 1974, *The Intensity Interferometer*, Taylor & Francis LTD, London
- Brown, R. Hanbury; Davis, J. and Allen, L. R., 1967, *MNRAS*, 137,375
- Brown, R. Hanbury; Davis, J.; Allen, L. R. and Rome, J. M., 1967, *MNRAS*, 137,393
- Celik, O., 2005, Private communication
- Chesneau, O. et al., 2003, *A&A* 410, 375
- Cornils, R., et al., 2003, *Astroparticle Physics*, 20, 129
- Davies, J.M. & Cotton, E.S. 1957, *Journal of Solar Energy*, 1, 16
- Davis, J. et al., 2005, *MNRAS*, 356, 1362

- Gamo, H., 1963, *Journal of Applied Physics*, 34, 875
- Grindlay, J. E., et al., 1975, *Astrophysical Journal*, 201, 82
- Grindlay, J. E., et al., 1975, *Astrophysical Journal*, 197, L9
- Hanna, D. S., et al., 2002, *Nucl. Inst. Meth. A* 491, 126
- Herrero, V., 1971, *Astronomical Journal*, 76, 198
- Kervalla, P. et al., 2004, *A&A*, 426, 297
- Kervalla, P., 2006, *Mem.S.A.It.*, 77,227
- Krennrich, F., et al., 2003, *New Astronomy Reviews*, 48, 345
- Kubo, H., et al., 2004, *New Astronomy Reviews*, 48, 323
- LeBohec and Holder, 2005, in *Proc. of "Towards a Network of Atmospheric Cherenkov Detectors VII"*, Palaiseau, Eds. B. Degrange and G. Fontaine, 577
- LeBohec and Holder, 2005, in *Proc. of 29<sup>th</sup> ICRC*, Pune, India, 5, 411
- Lorenz, E., 2004, *New Astronomy Reviews*, 48, 339
- Michelson, A. A. and Pease, F. G., 1921, *Astrophysical Journal*, 53, 249-259.
- Michelson, A. A., 1920, *Astrophysical Journal*, 51, 257
- Monnier, J. D., 2003, *Rep. Prog. Phys.*, 66, 789
- Mozurkewich, D. et al., 2003, *AJ*, 126, 2502
- Ofir, A. and Ribak, E. N., 2006a, accepted for publication in *MNRAS*, astro-ph/0603111
- Ofir, A. and Ribak, E. N., 2006b, accepted for publication in *MNRAS*, astro-ph/0603112
- Paneque, D., et al., 2003, *Proceedings of the 28<sup>th</sup> ICRC*, Tokyo, Japan
- Pare, E. et al., 2002, *NIM A* 490, 71
- Quirrenbach, A., et al., 1993, *AJ*, 106, 1118
- Tai, RZ., 2000, *Rev. Sci. Instrum.*, 71, 1256
- ten Brummelaar, T. A., et al. 2005, *ApJ*, 628, 453



Tycner, C., et al., 2004, ApJ, 127, 1194

Tycner, C., et al., 2006, AJ, 131, 2710

van Belle, G. T., et al., 2006, ApJ, 637, 494

van Belle, G. T., 1999, PASP, 111, 1515

Yang, L, et al., 1994, Rev. Sci. Instrum., 66,2281

Weekes, T. C., 2003, Very High Energy Gamma-Ray Astronomy, Taylor & Francis, isbn:  
0750306580

Young, J. S., et al., 2000, MNRAS, 315, 635

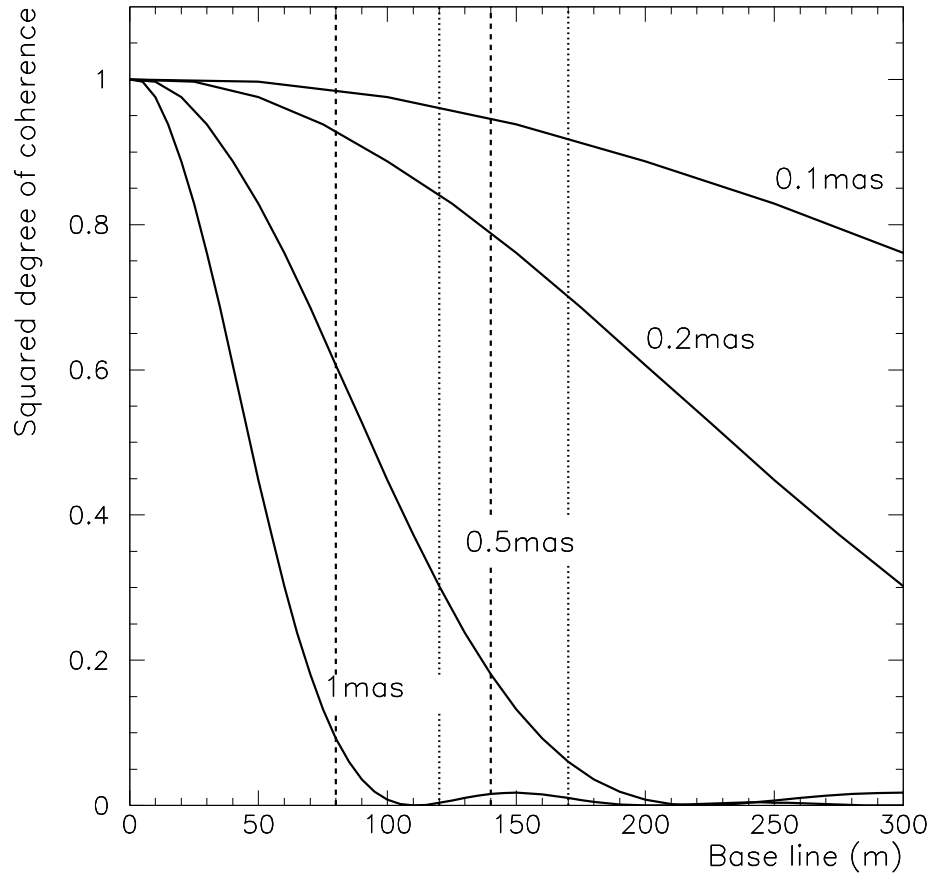

Fig. 2.— The squared modulus of the degree of coherence of the light at two telescopes as a function of the baseline for different stellar diameters. The dashed and dotted lines indicate the baselines at zenith in VERITAS-4 and HESS-4 respectively.

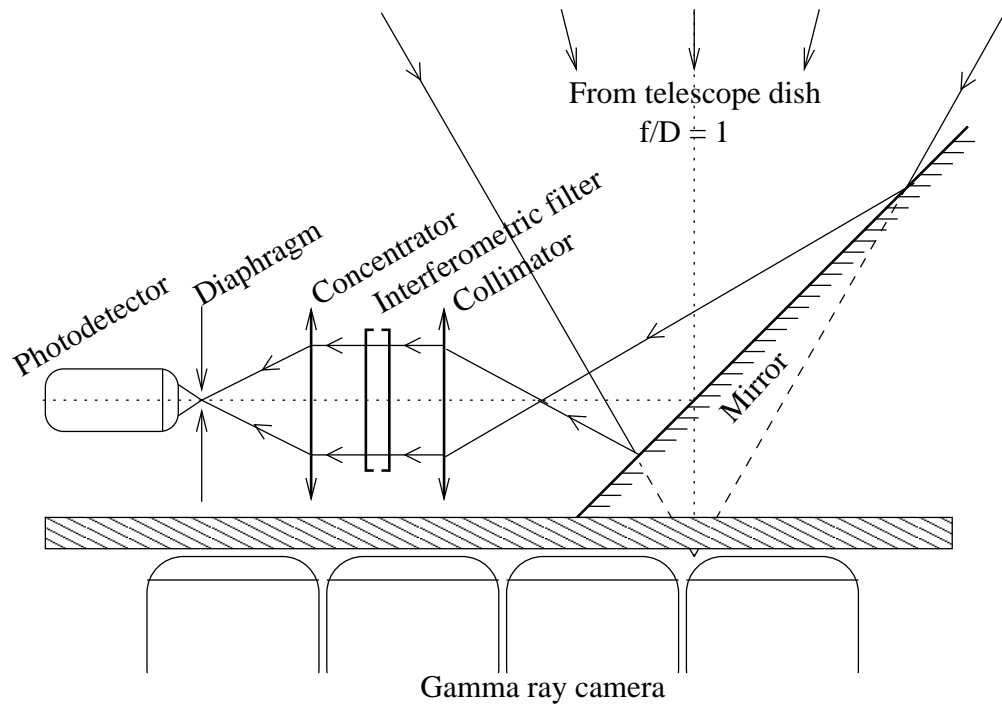

Fig. 3.— The light from the telescope is redirected sideways by a mirror, it is then collimated, filtered and focused onto the photo-detector.

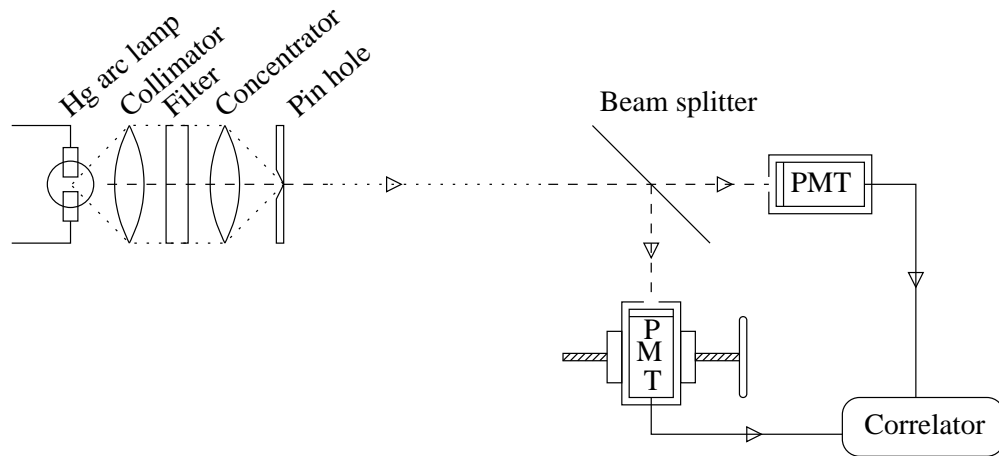

Fig. 4.— The light from a mercury arc-lamp is filtered and focused on a pinhole to form an artificial star of known diameter. Two photo-detectors are virtually overlapped by means of a semi-reflective glass for the zero base-line measurement and the correlation is measured as a function of the lateral displacement of one with respect to the other.

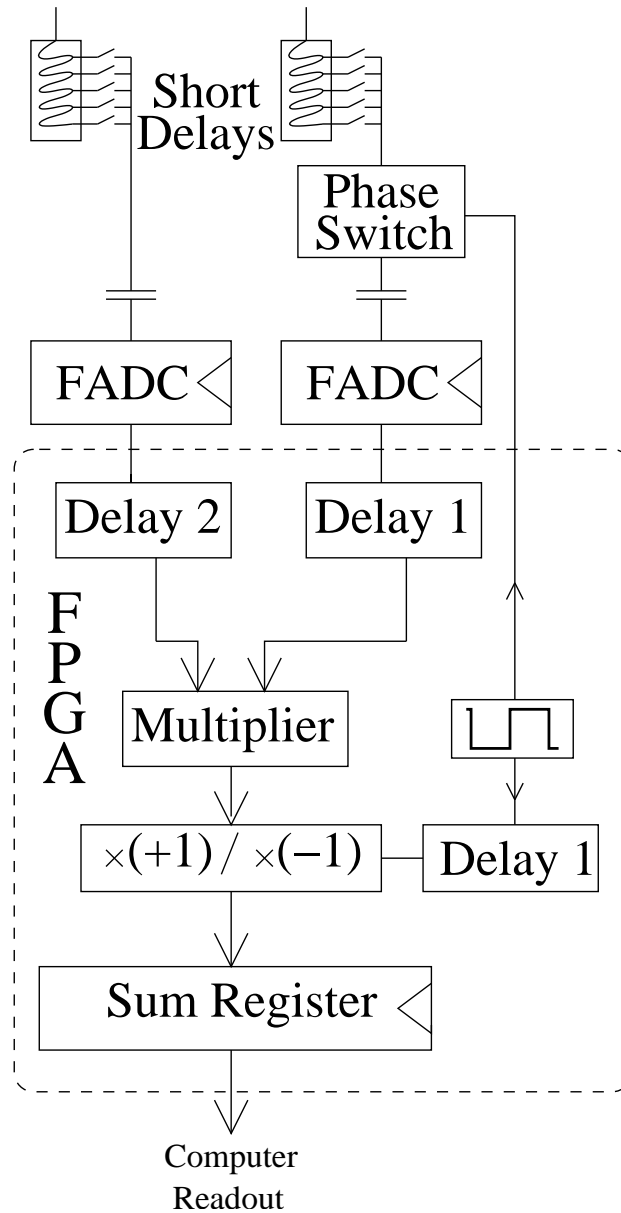

Fig. 5.— Short programmable delay lines can be used to set the relative timing of the two channels to a fraction of the digitization period. Large time corrections can be done on the digitized samples. The phase of one of the two signals is inverted with a 50% duty cycle before digitization. Digital samples are multiplied together. In order to demodulate the correlation signal, the sign of the product is inverted during phases when the phase of the analog signal is inverted. The result is accumulated in a sum register.

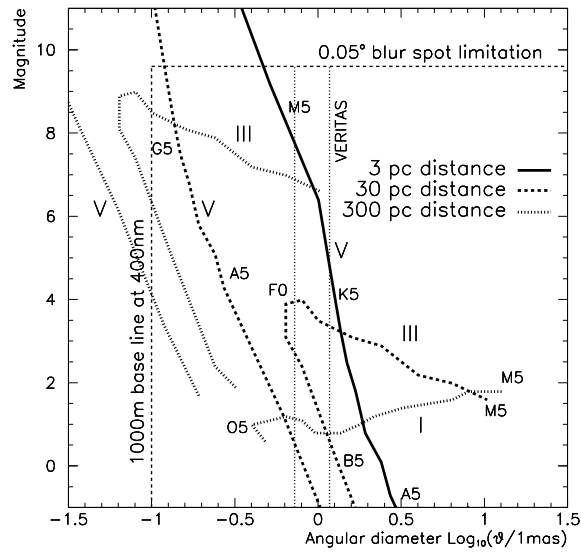

Fig. 6.— Visual magnitude - angular diameter relationship for the main sequence, the giant and the super-giant branches for distances of 3 pc, 30 pc and 300 pc. The magnitude limitation resulting from a  $0.05^\circ$  optical point-spread function is indicated, as well as the VERITAS baselines as an example. Future atmospheric Cherenkov telescope arrays might provide baselines of 1 km.