JUSTACT⁺: JUSTIFIED AND ACCOUNTABLE ACTIONS IN POLICY-REGULATED, MULTI-DOMAIN DATA PROCESSING *

CHRISTOPHER A. ESTERHUYSE ^a, TIM MÜLLER ^a, AND L. THOMAS VAN BINSBERGEN ^a

Informatics Institute, University of Amsterdam, Amsterdam, The Netherlands
e-mail address: c.a.esterhuyse@uva.nl, t.muller@uva.nl, ltvanbinsbergen@acm.org

ABSTRACT.

Inter-organisational data exchange is regulated by norms originating from sources ranging from (inter)national laws, to processing agreements, and individual consent. Verifying norm compliance is complex because laws (*e.g.*, GDPR) distribute responsibility and require accountability. Moreover, in some application domains (*e.g.*, healthcare), privacy requirements extend the norms (*e.g.*, patient consent). In contrast, existing solutions such as smart contracts, access- and usage-control assume policies to be public, or otherwise, statically partition policy information at the cost of accountability and flexibility. Instead, our framework prescribes how decentralised agents *justify* their actions with policy fragments that the agents autonomously create, gossip, and assemble. Crucially, the permission of actions is always reproducible by any observer, even with a partial view of all the dynamic policies. Actors can be sure that future auditors will confirm their permissions. Systems centralise control by (re)configuring externally synchronised *agreements*, the bases of all justifications. As a result, control is centralised only to the extent desired by the agents.

In this paper, we define the JustAct framework, detail its implementation in a particular data-processing system, and design a suitable policy language based on logic programming. A case study reproduces BRANE – an existing policy-regulated, inter-domain, medical data processing system – and serves to demonstrate and assess the qualities of the framework.

1. INTRODUCTION

Data exchange systems are distributed systems facilitating the controlled sharing, trading, and processing of (often large) datasets and analysis results within data exchange applications, increasing the public, commercial, or academic value of collected data. Following the inter-organisational nature of data exchange systems and the (market- or privacy-)sensitive nature of the exchanged assets, collaborating organisations adopt complex governance models [TGMD22] in an attempt to ensure compliance with regulations and contractual

Key words and phrases: Decentralised, Framework, Composition, Coordination, Multi-agent System, Policy, Program Refinement, Specification.

* This article is a significantly extended version of [EMvB24]. The JustAct framework definition in Section 3 has more explanations and examples, and key properties are defined more explicitly. The major changes are to the prior implementation and case study sections. The implementation section is replaced by Sections 4 and 5, which, together, implement the framework as a particular policy interpreter and data exchange runtime system. The prior case study is replaced by Section 6, which evaluates the framework via a reproduction of BRANE, an existing policy-regulated medical data processing system.

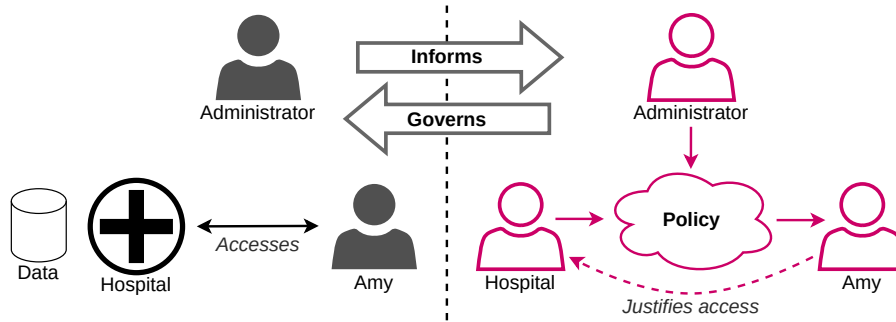

Figure 1: Conceptual use-case of the framework. Agents autonomously choose to act, accessing data in the real world (left), as permitted by their shared policies (right).

agreements. In support of such governance models, high levels of control should be given to organisations to influence the execution of data exchange applications, *e.g.*, via access control [QTD⁺20, SdV00] or usage control [JD22, ZPSP05, MLP⁺19]. Furthermore, high levels of accountability are required to support dispute resolution [SMV⁺19] and to demonstrate legal compliance [CT22]. Data exchange systems exhibit a fundamental trade-off between maximising the availability of data to data users and maximising the control over data to data owners, subjects, and (privacy) authorities. In this work, we present a framework that enables the organisations collaborating in a data exchange system to formalise their shared and individual positions with respect to this trade-off through powerful, declarative *policies*.

Our approach is to define a framework for runtime systems that specify the interaction between system dynamics (messages and actions) and statics (policies and facts). In one direction: agent messages create and disseminate policies. In the other direction: policies specify which actions are permitted. Actors are held responsible for collecting and providing valid *justifications* of their actions: sufficient policy information to prove permission. Crucially, permission is decidable, despite the agents having only partial knowledge of the existing policies, as policies can be changed dynamically. Actors can thus be confident that other actors (*e.g.*, auditors) will agree that their actions were permitted. Figure 1 visualises this process; human users and automated services reason about and influence the behaviour of their peers by creating and sharing policies. The framework standardises the meaning of well-behavedness: act only as permitted. However, its *enforcement* is an orthogonal matter; implementations of the framework can prevent non-permitted actions (*ex-ante* enforcement), recognise and punish misbehaviour after it has happened (*ex-post* enforcement), by a centralised authority, in a peer-to-peer fashion, or whatever mixture is appropriate. As such, our framework admits flexibility in the implementation of runtime systems whilst ensuring large degrees of control for agents and their mutual agreement(s).

Agents express and communicate consistently by using a (shared) *policy language*, which is fixed by the instantiation of the framework. However, different languages are available, and their characteristics determine the power and complexity of policies. In this article, we characterise the space of suitable languages in general, and demonstrate two languages in particular. In the earlier sections, we use *Datalog*[¬] to easily exemplify key concepts. Later, we define *Slick* as a *Datalog*[¬] variant, and use it to express more realistically complex policies. To minimise the burden on the reader, both languages are based on the intuitive and ubiquitous *Datalog* language, and are sufficiently characterised within the article.

This work reports on the ongoing developments of generic, policy-driven data exchange systems that satisfy legal requirements. We intend to make our approach an integral part of the EPI framework [KME⁺24], to improve its accountability, auditability, and preservation of user privacy. This article reflects our latest steps in this direction. We implement a generic data exchange system around our framework. Then we conduct a case study, detailing and evaluating the application of our implementation to new and existing usage scenarios of the BRANE system, which is the component of the EPI framework responsible for coordinating and regulating the execution of medical data processing workflows. Precisely, after we summarise some background literature (Section 2), we contribute:

- (1) the definition of a **framework** for multi-agent runtime systems in which agent actions are regulated by policies that agents autonomously create and share (Section 3),
- (2) an **implementation** of a generic data exchange system which uses our framework to let agents regulate the exchange of data via some configured policy language (Section 4),
- (3) definition of the Slick **policy language** and interpreter, for expressing policies with realist abstractions and relationships (Section 5), and
- (4) a **case study**, evaluating our framework, instantiated for data exchange, regulated by Slick policies, in application to BRANE’s medical workflow processing scenarios (Section 6).

We discuss our contributions by their own merits (Section 7) and in comparison to related work (Section 8) before we conclude with a summary (Section 9).

Note that the source code for our implementations and experiments are included in the ancillary materials, including the Rust implementations of the framework as an ontology, the data exchange runtime system, the runtime-trace analyser tool, the Slick interpreter, the initialisation of the prototype for BRANE, and the unit tests implementing our experiments.

2. BACKGROUND

2.1. Distributed Systems and Algorithms. *Distributed systems* model the distribution of a stateful *configuration* over a set of *processes*; each process has its own local *state*. *Distributed algorithms*, when implemented by each process, give systems useful emergent properties. Often, these algorithms are defined in terms of only basic message-passing primitives, comparable to the IP and UDP protocols in networking: messages are asynchronous, and message delivery is unreliable. Some algorithms solve complex distributed problems (*e.g.*, self-stabilisation), and create useful abstractions over the distributed system (*e.g.*, synchronisers).

In this work, we refer to two classes of algorithms. Firstly, *gossip* protocols disseminate information by replicating and forwarding messages from peer (process) to peer, resulting in decentralisation and robustness, by imposing minimal requirements on the network topology and process behaviour [BCFH08]. Secondly, *consensus algorithms* establish fundamental agreement on the selection of a particular value, consistently among processes. Consensus has been well-studied for decades [RBA05], but has seen renewed interest in application to blockchain technologies in, for example [KdHH22, KT22].

2.2. Multi-Agent Systems and Autonomy. The field of *multi-agent systems* studies processes (called *agents*) that exhibit social phenomena as a result of their *autonomy*: agents are motivated by goals to draw from their partial information to act on shared resources and interact with other agents. The literature explores the problems of distributed systems, but

also explores a variety of (software models of) social organisations, ranging from cooperative data-sharing *consortia* (e.g., in [Fer23]) to competitive markets (e.g., in [ZBL⁺23]).

Agent-oriented programming studies the programming of agents, balancing the concerns of software (language) engineering and object-oriented programming, but with a unique emphasis on agent autonomy. For example, agent autonomy also tends to improve system scalability and robustness. These ideas are present in seminal agent-oriented programming works such as [Sho93] and persist into more recent works like the survey [MWY17].

2.3. Policy Specification Languages. We give a brief overview of the various notions of ‘policy’ which were developed by various disciplines and which influenced our work.

Access control is a mainstay in cyber-physical systems (e.g., from databases to IoT networks) that revolves around the regulation of agents accessing resources. For example, a policy specifies in which case a given agent is *authorised* to read or write a given data asset. Policies often take the form of conditional rules [San98, FJT22], sometimes applied in the context of meta-data attributes [SO17]. *Usage control* generalises access control to the control of usage events that occur for the *durations* of time the resource is being used. Usage authorisation must be maintained and can be interrupted [AK22] which may be realised with continuous monitoring [HIA⁺23] and mutability of attributes [SP03]. XACML [ANP⁺03] and ODRL [Ian07] are popular, standardised policy languages for expressing access and usage conditions as policies. For example, [UMSB12] implements usage control in XACML.

Normative specifications define fundamental normative positions (relations) such as powers, duties, rights, obligations, and permissions [AGNvdT13] between actors. Normative specifications can formalise (and make machine-readable) the norms described in normative documents such as laws and regulations, organisational policies, and contracts. Laws and regulations are specified to apply to activities of particular kinds within particular jurisdictions. For example, the European Union’s General Data Protection Regulation (GDPR) [Eur16] regulates the processing of personal data within the European Union, but its wide reach and impact makes it influential even outside the EU.

The study of norms reflects its long history in its rich nomenclature, for example, [BvdT08] clarifies the relationship between *substantive* and *procedural* norms, and [GIM⁺18] defines the *open-texture terms* that occur in norms: they (intentionally) leave room for interpretation, e.g., by a judge during the resolution of a particular dispute. Normative specification languages attempt to capture this nomenclature to enable the encoding of norms such that they can be used as enforceable policies within software systems.

A wealth of literature connects the aforementioned notions of policy, with the express goal of clarifying their interrelations and regulating the behaviour of (actors within) software systems. For example, the eFLINT language [vBLvDvE20] formalises norms using the Hohfeldian framework of legal proceedings [Wes13] and has been used for access control [vBKB⁺21]. Symboleo [SPA⁺20] is also based on Hohfeld’s framework but, contrary to eFLINT, is focussed on contract specifications. Fievel [VC07] is a language used to verify properties of (social) institutions. These languages afford the application of various tools and techniques to policies. For example, model-driven development [S⁺06] and model-checking for high-level properties in policies of both Fievel [VC07] and Symboleo [PRR⁺22].

Recently, [EvB24] explored the *cooperative specification* of a policies, a process in which multiple agents develop a shared policy together, taking turns contributing to the policy. Crucially, the ongoing cooperation is regulated by a meta-level agreement between the agents constituting when a policy is considered *valid*. Suitable policy languages must define

this semantic notion of validity, giving the agents meaningful control over the policy being developed. For example, Amy formalises “Only Amy can access Amy’s data” which would be invalidated by Bob’s contribution of “Bob accesses Amy’s data”; Amy’s contribution captured a meaningful constraint on Bob’s contribution, and thus also on the developed policy.

2.4. Logic Programming and Datalog[⊃] in Particular. *Logic programming* languages are designed to operationalise various logics: logic programs encode logical theories. Here, we give an account of Datalog[⊃] sufficient to understand the Datalog[⊃] examples in Section 3.

Datalog, overviewed in [CGT89], is a simple logic programming language: each program is a set of *Horn clauses* called *rules*. Precisely, each rule has the form $(c_1 \wedge c_2 \wedge \dots \wedge c_m \leftarrow a_1 \wedge a_2 \wedge \dots \wedge a_n)$, where *consequents* $c_1 \dots c_m$ and *antecedents* $a_1 \dots a_n$ are *facts*, each of which is constructed from a *predicate* symbol p and a set of *constants* symbols and first-order variables over constants. Intuitively, each rule with variables encodes the set of variable-free rules with all variables consistently substituted with any conceivable combination of constants. The Datalog semantics gives each program a *model*, mapping *ground* facts (without variables) to Boolean values, which we interpret as distinguishing the facts that are *true* from *false*; each fact is true iff derivable by a rule in the program. Most of the literature and tools use the same concrete syntax: (\leftarrow) and (\wedge) are denoted $(:-)$ and $(.)$, respectively, and only variable identifiers begin with uppercase letters. For example, `knows(amy, Person) :- knows(Person, amy)` formalises “each person known by Amy knows Amy”; note that `amy` is a constant, while `Person` is a variable. Implementations of Datalog all ultimately let users inspect the model.

Various dialects of Datalog have been studied in the literature, exploring the combination of various features. Datalog[⊃] [SZ94] is a useful generalisation: antecedents may be negated (with \neg , typically concretely denoted `not`), conditioning the truth of some facts on the falsity of others. This strictly improves expressiveness [KK20], because it affords *non-monotonic reasoning*: adding rules may *remove* truths [SA19]. For example, fact `sun` is true in program `sun :- not clouds`, but false after rule `clouds` is added; we say `sun` is *falsified*. Unfortunately, not all Datalog[⊃] programs have unique logical interpretations. Accordingly, different semantics exist (*e.g.*, stable model [GL88] and well-founded [VGRS91]) that attribute different models to these *unstratified* (defined in [Ros90]) programs. For example, what should be the value of p in `p :- not p`? Fortunately, we consider no such programs in this article.

Several tools can interpret (super-languages of) Datalog[⊃]. For example, the Clingo answer-set solver [GKK⁺11] can interpret each Datalog[⊃] example in this article.

3. THE JUSTACT FRAMEWORK FOR MULTI-AGENT RUNTIME SYSTEMS

This section defines the framework by defining its key concepts and their properties, along with explanations, motivations, and examples. We summarise the framework as follows:

- Agents make statements carrying policies that model the system.*
- Agents gossip, assemble, and validate statements to build valid justifications.*
- Agents only take actions that are permitted by their justifications.*

The essence of the framework is captured by the *framework ontology*, visualised in Figure 2: a collection of sets and functions capturing concepts and their relationships. We distinguish between *static* and *dynamic* concepts, and discuss each in a dedicated subsection. The framework is to be *instantiated* by a runtime system that defines the framework’s sets and functions such that the *framework requirements* are preserved; together, Sections 4 and 5

define such an instantiation. The most fundamental framework requirements are expressed in the figure; for example, each *action* has exactly one *justification*, and each *agreement* is a *message*. The remaining framework requirements are introduced throughout this section. The framework guarantees Properties 3.1 and 3.2, *i.e.*, agents always agree on action *permission* and *effects*, which are both precisely defined in Section 3.2.

Ultimately, we explain how agents can act autonomously while enforcing the *well-behavedness* (Definition 3.1) of themselves and their peers in practice.

Property 3.1. *Agents always agree whether a given action is permitted.*

Property 3.2. *Agents always agree on the effects of a given action.*

Definition 3.1. *An agent is well-behaved while all their actions are permitted.*

The rest of the section discusses the framework in general and incrementally builds an example framework instantiation using policies built from only the Datalog[⊃] rules in Table 1. We use a running example of well-behaved agents Amy and Bob. Ultimately, Bob enacts the deletion of Data1, justified by the policy $\{r_d\}$.

Henceforth, we use the following notation. We use \triangleq to define new terms, and use $=$ to construct propositions of equality. We denote disjoint set union as \uplus , *i.e.*, $a \uplus b = a \cup b$ iff sets a and b are disjoint, and otherwise, $a \uplus b$ is undefined.

3.1. Statics. The framework statics are fixed at runtime. They concern the fundamentals of the framework: data types and the syntax and semantics of the policy language. Agents reason about structure and relationship between given statics without having to communicate.

The **agents**¹ of the framework author **messages** occurring dynamically as statements, *i.e.*, the messages are fixed statically, and some subset of messages are *stated* per runtime state.

¹Unless otherwise specified, let framework agents coincide with agents of the underlying distributed system.

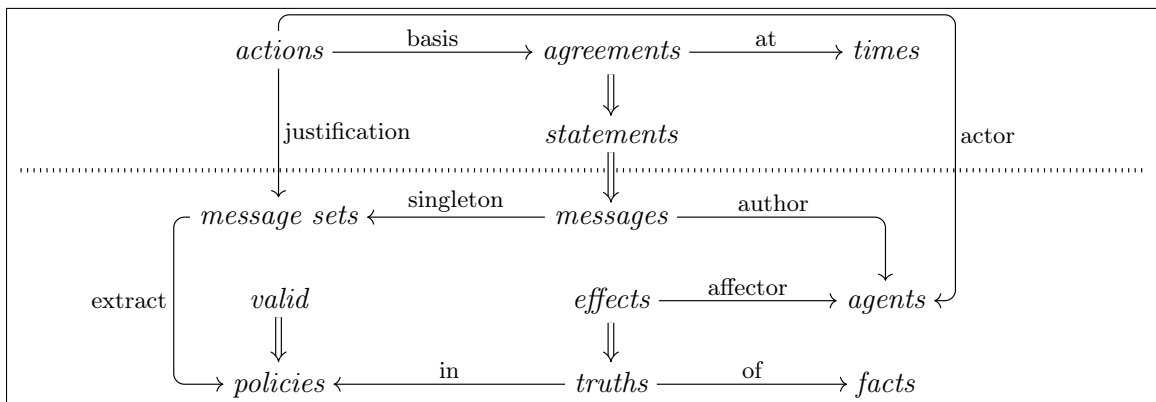

Figure 2: Graphical depiction of the *framework ontology*. Sets (italicized) are related by pure, total functions (\rightarrow and \Rightarrow arrows) from domain to co-domain. Each (\Rightarrow) denotes an identity function, *e.g.*, $statements \subseteq messages$. Functions are identified by their co-domain (or by a label if given). The dotted line distinguishes sets and functions that are *dynamic* (above) and *static* (below). At runtime, new elements may be added to dynamics, but statics are fixed.

Statements communicate **policies** (see **extract** below). We take for granted that (\in) and *singleton* relate messages to *message sets* as expected. The **truths** define a relation over facts and policies, whose membership we test with $true(f, p) \triangleq \exists t \in truths : of(t) = f \wedge in(t) = p$. Alternatively, each policy prescribes which facts are true. In the examples throughout this section, we instantiate policies as the subsets of the (*policy*) *rules* shown in Table 1. Hence, (\cup) is a natural policy-composition operator, uniting rules. But note that uniting rules does not generally unite truths. We use the semantics of Datalog⁻, as it is informally explained in Section 2.4, to define facts and truth: f is true in p iff $f \in [p]$, the *stable model* of policy p , e.g., when $f = \mathbf{error}$ and $p = \{r_m\}$. Finally, **effects** are a special subset of truths that each identifies its **affector** agent. In Section 3.2, we explain how effects are the foundation for the interface between the runtime system and the outside world. In our example instantiation, we let (only) truths of `ctl-deletes(bob, data1)` be effects, affected by Bob.

The definition of **valid** fixes the distinction between useful and useless policies, as a function of their contents. We instantiate **valid** to characterise policies without errors; precisely, we let $p \in valid \triangleq \neg true(\mathbf{error}, p)$. Despite the simplicity of this definition, (in)validity emerges from complex rule interactions, which is key to policies capturing the complex relationships between domain concepts. As a simple example, no valid policy is a superset of $\{r_m, r_n\}$, as these rules suffice to ensure that **error** is tautological, i.e., true in any case. Intuitively, $\{r_m, r_n\}$ captures the requirement that there must be a single consistent answer to the question: must Amy confirm? Section 6.2.2 demonstrates how rules conditioning (in)validity lay the groundwork for complex inter-agent power dynamics.

Most directly, **extract** relates messages to their policy contents. However, it also determines which policies agents are capable of expressing. For example, agent a simply cannot express p if *extract* maps no statements to p . Intuitively, *extract* can ensure that the extracted policy reflects its author(s). Hence, we understand the policy $extract(m)$ as the subjective assertions of agent $author(m)$. For our running example with Datalog⁻, we instantiate *extract* as a pure function of the message author and the message *payload*, which is an arbitrary policy, chosen by the author. Intuitively, *extract* invalidates payloads on the condition that they include any undesirable author-rule pairs. Precisely, we let $extract(\{m\}) \triangleq payload(m) \cup \{\mathbf{error} \mid \forall (r, a) \in owns : (r \in m \wedge \neg author(m, a))\}$, where *owns* relates rule r to agent a if r has an antecedent whose predicate is prefixed by `ctl-` and whose first parameter is constant a . For example, only Bob owns rule `ctl-deletes(bob, data1)`, while rule `error :- confirms(amy)` has no owner because fact **error** has neither prefix `ctl-` nor a constant first parameter. Throughout this article, we always close the definition of *extract* such that it distributes over messages. Precisely, we let $extract(\emptyset) \triangleq \emptyset$, $extract(\{m\} \uplus M) \triangleq extract(\{m\}) \cup extract(M)$. This definition confers a property that simplifies reasoning: *extract* commutes and associates over message set union. As agents agree on the definition

Name	In natural language	As Datalog ⁻ rules
r_m	Amy <u>must</u> confirm.	<code>error :- not ctl-confirms(amy)</code>
r_n	Amy must <u>not</u> confirm.	<code>error :- ctl-confirms(amy)</code>
r_c	Amy <u>confirms</u> if someone is trusted.	<code>ctl-confirms(amy) :- ctl-trusts(amy, X)</code>
r_t	Amy <u>trusts</u> Bob.	<code>ctl-trusts(amy, bob)</code>
r_d	Bob <u>deletes</u> Data1.	<code>ctl-deletes(bob, data1)</code>

Table 1: Example (*policy*) *rules* expressed in Datalog⁻ and natural language. Each rule’s name is suggested by the underlined keyword. A policy is any rule set.

of `extract`, its design affords the opportunity to agree on the fundamental limitations on which subjective assertions are available to each agent. For example, for any message set M where $\text{true}(\text{ct1-deletes}(\text{bob}, \text{data1}), \text{extract}(M))$, either M includes messages authored by Bob, or $\text{extract}(M)$ is invalid. Intuitively, Amy alone cannot assert that Bob deletes Data1.

3.2. Dynamics. Elements of framework dynamics are fixed in each system configuration at runtime. They instantiate the statics and must be stored and communicated by agents. Figure 3 illustrates the agents’ partial views on some dynamic system configuration.

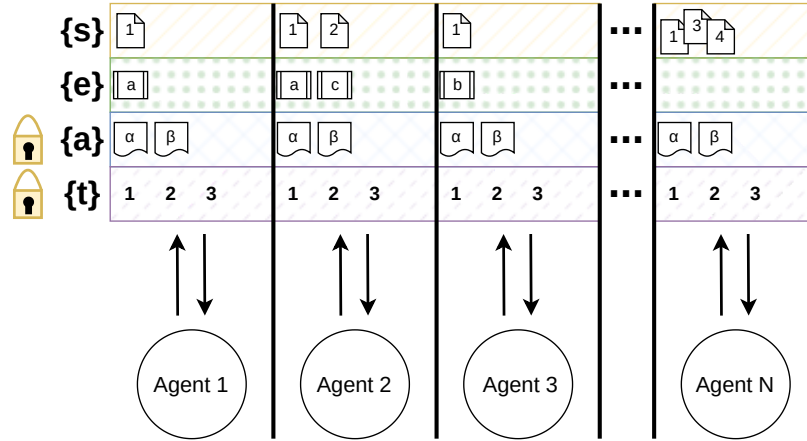

Figure 3: Graphical depiction of a dynamic configuration, where each agent has a partial view of all (s)tated messages, (e)nacted actions, (a)greements, and current (t)imes. Agents have the (same) global view of the agreements and current times.

At runtime, a subset of messages are **statements** because they have been stated, and then potentially shared with other agents. Intuitively, statements have few restrictions, but therefore, they have little impact on their own. They are meaningful because of their relationship with actions. In practice, we expect each statement to be *autonomously* created by its author, *i.e.*, as decided by the author alone. In theory, the set of statements grows forever. In practice, agents and networks have finite storage capacities, so we let agents forget or discard statements. For our purposes, it suffices if the existence of a given statement is semi-decidable: an agent can decide that statement m exists by observing it, and can prove its existence to other agents by showing them m . In practice, the integrity and provenance of statements is preserved by authors cryptographically signing their statements, and agents ignoring statements without their authors’ signatures. Agents share statements with their peers (*e.g.*, via gossip), for their own reasons, and at their own pace. Section 6 demonstrates a case where an agent intentionally withholds a statement from other agents.

Agreements attribute special meaning to selected statements at selected **times**. We require that membership be decidable, *i.e.*, Property 3.3. Intuitively, this lays the groundwork for agents agreeing which actions are permitted. In practice, agents explicitly synchronise the growing set of agreements. In real systems, synchronisation may be infrequent and agreements may be expressed sparsely; *e.g.*, one synchronisation creates agreements for each time in the range from 100 to 500. But for clarity in this article, we represent and synchronise individual agreements explicitly. In our running example, Amy and Bob agree on a statement with policy $\{r_m\}$ that applies at time 1. In general, it is crucial for the runtime system

to preserve Property 3.3: agents must always agree which subset of times are *current*. We call agreements current if their time is current. Thus, agents can add and remove current agreements over time, but they maintain agreement on the growing set of agreements per fixed time. We expect agents to rely on this to robustly reason about the agreements at prior and hypothetical future times. For example, even after the current time is changed to 2, Amy and Bob agree on the agreements at time 1, and that those are not current. As we expect it to be practical in general, in our examples, we let agents a single current time, *i.e.*, the current time is a variable that agents synchronously overwrite.

Property 3.3. *Agents always agree on the current times and the (current) agreements.*

At runtime, there is a growing set of (taken) **actions**. Each action has a defined *actor* agent, justification² (a set of messages), and *basis* agreement. We say the action is taken at the time of its basis. Like statements, actions are created autonomously (by their actors) and then shared between agents by unspecified gossip. Unlike statements, actions are restricted such that they can be effectful and meaningful. Precisely, *well-behaved* agents take only *permitted* actions. Well-behavedness has only extrinsic value, because agents trust and expect their peers to be well-behaved and may suffer external consequences otherwise. For example, by agreeing on the statement with payload $\{r_m\}$, Amy and Bob agree that actions are not permitted without Amy’s confirmation. Amy can choose to trust Bob to remain well-behaved by accessing Data1, assuming it will not be deleted unexpectedly. All observers agree that Bob is not permitted to enact the deletion of Data1 without Amy’s confirmation.

Definition 3.2. *well-behaved*($\alpha : agent$) $\triangleq \forall a \in actions, (actor(a) = \alpha) \rightarrow permitted(a)$.

Definition 3.3. *permitted*($a : action$) \triangleq

$$\begin{aligned} & justification(a) \subseteq statements && \text{(stated justification)} \\ \wedge \text{agreed}(basis(a)) \in justification(a) && \text{(based justification)} \\ \wedge \text{extract}(justification(a)) \in valid && \text{(valid justification)} \\ \wedge at(basis(a)) \in current. && \text{(current action)} \end{aligned}$$

Here we break down and explain Definition 3.3: whether a given action is permitted, in the context of a fixed (dynamic) system configuration. Firstly, justifications must consist entirely of **stated** messages. This ensures that justifications reflect the existing assertions of their respective authors, *i.e.*, and not arbitrary policies in conceivable messages. Hence, agents restrict actions by withholding their statements. For example, Amy cannot justify actions in terms of Bob’s hypothetically-stated messages; Bob must state them first! Secondly, justifications must be **based**, *i.e.*, include their basis agreement. Thus, the meaning of a justification is regulated by its basis. For example, `ct1-trusts(amy, bob)` is necessarily true in all justifications based on $\{r_t\}$. Thirdly, (the policy extracted from) each justification must be **valid**. These justifications have internally-consistent meanings. For example, recall that only Bob owns r_d . Hence, Amy can make statements whose payloads include r_d , but those statements can be safely ignored, as they are useless in justifying permitted actions. In general, definitions of validity are useful if they enable meaningful reasoning about policies in terms of their parts. For example, for any conceivable policy p , the composite policy $\{r_m, r_n\} \cup p$ is invalid, because r_m and r_n place contradictory conditions on validity: Amy

²In the prior version of this article [EMvB24], one message in the justification is *enacted*, determining the action effects. Here, we instead unify these concepts. Messages can be specialised via policy if necessary.

cannot both confirm and not confirm! Finally, actions must be **current**: based on a current time. This is the only component of permission that may be falsified in the future, *i.e.*, all the other components that hold at present necessarily hold in the future. In general, we expect agents to reason about historical and hypothetical system configurations; they come to reliable conclusions. For example, Amy and Bob agree to change the current time from 1 to 2. Actions permitted at time 1 are unaffected, but they are no longer permitted at the current time. Instead, new actions are permitted, based on the agreement $\{\}$ at time 2. Section 6.2.2 lays out a realistically complex agreement and discusses its underlying intuition by reasoning about the actions it permits. Thereafter, Section 6.3.5 demonstrates changing this agreement by adding a changed agreement and changing the current time.

Ultimately, Definition 3.4 defines the (enacted) effects of a given action. Like actions, the enacted effects grow dynamically at runtime. However, where actions are user-defined during instantiation (hence, actions are included in Figure 2), the definition of enacted effects is fixed by Definition 3.4, derivable from the actions themselves; hence, *e.g.*, agents can communicate enacted effects implicitly by explicitly communicating actions. Enacted effects are intended to trigger events external to the system; we say these effects are *realised*. For example, Bob realises the enacted effect `ct1-deletes(bob, data1)` by deleting the asset data identified by `data1` from an external database. Note that the framework distinguishes actors (which collect justifications, take actions, and affect well-behavedness) from effectors (which are associated with effects). This allows for instantiations in which these roles are decoupled. However, in this article, instantiations and agreements are designed such that, in all permitted actions, these roles necessarily coincide.

Definition 3.4. *enacted-effect*($e : \text{effect}, a : \text{action}$) \triangleq *of*(e) = *extract*(*justification*(a)).

Ultimately, the utility of the framework is how it systematises the cooperation between agents using policies to define, constrain, and enact the permitted actions and their effects. This is achieved despite actions and statements being autonomously created and gossiped. Hence, agents can work towards unrelated actions concurrently. Nevertheless, by fixing the semantics of the policies, and by synchronising the agents' views on the current agreements, the agents can rely on Properties 3.1 and 3.2: the agents maintain agreement on the permission and effects of every conceivable action. Well-behaved agents can work toward realising particular, desirable effects by reasoning backwards from the effect to the necessary actions, and then further to the necessary times, agreements, and statements. Our running example is concluded as Bob takes a final action at time 2, based on the trivial agreement, and justified by policy $\{r_d\}$. Amy, Bob, and future auditors all come to the same conclusions: this action is permitted and has the effect `dt1-deletes(bob, data1)`.

In general, there are many approaches to enforcing the well-behavedness of agents. In fact, we expect a mix of approaches to be used in practice. We expect benevolent agents to systematically enforce their own well-behavedness via *ex-ante* enforcement; *i.e.*, these agents check for permission before acting. Cautious agents can await proof of permission from their peers before accepting their actions. Agents with limited resources can trust their peers by assuming that their actions are permitted, instead relying on auditors to punish peers for bad behaviour after the fact. We consider it sensible for agents to be accountable for their own actions; (1) actors must always be ready to prove that their actions are justified, and (2) actors cannot hide their actions, *e.g.*, to feign well-behavedness. Additional safety can be achieved via redundancy; for example, agents periodically audit suspicious actions, and agents assist auditors by reporting which actions they observed. Section 4 discusses the

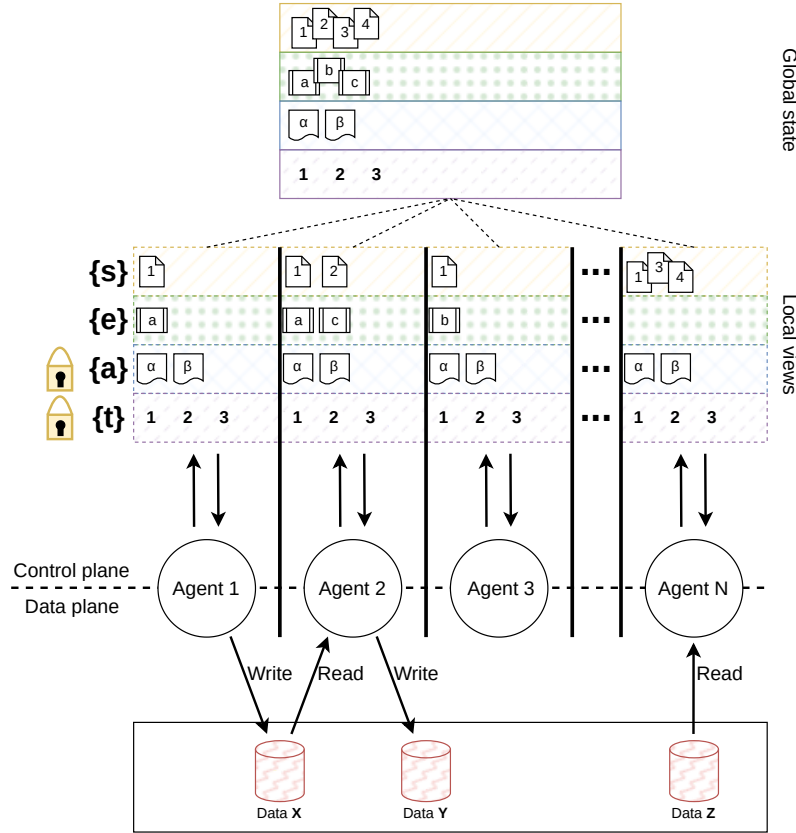

Figure 4: Graphical depiction of a dynamic system configuration implemented by our prototype. The control plane (above) inherits the architecture of the JustAct framework dynamics shown in Figure 3: agents have partial views on control-level meta data. Agent views are implemented as masks over a central meta data store. In the data plane (below), agents read and write data in another shared store.

choice and implementation of enforcement mechanisms, and then Section 6 demonstrates particular agents reasoning about and enforcing well-behavedness in particular scenarios.

4. IMPLEMENTATION: GENERIC DATA EXCHANGE RUNTIME SYSTEM

In this section, we design and implement a prototype multi-agent data exchange runtime system, which is architected around two complementary parts (visualised in Figure 4):

- (1) **The Data Plane:** Agents are motivated to create and share *data assets* with their peers. This is achieved by agents reading and writing assets in a shared asset store.
- (2) **The Control Plane:** Agents create and share asset policies and other asset meta-data in the control plane. This meta-data ultimately regulates the activities in the data plane.

The implementation instantiates the JustAct framework as the control plane. The interface between the control- and data-planes corresponds to the interface between the JustAct framework and its runtime environment: JustAct reading and writing *effects* in the control plane are *realised* as agents reading and writing data assets in the data plane.

This section leaves the JustAct statics relating to the *policy language* uninstantiated; hence, in isolation, this section contributes a runtime system that remains generic to the policy language. Section 5, to follow, completes the instantiation with a particular policy language. It is this complete instantiation which we use for the case study in Section 6.

4.1. Design Considerations. Data exchange systems are subject to many design considerations before they can be implemented in detail. Here, we explore particular design considerations, and explain the decisions reflected in our prototype implementations.

Firstly, **how is the (meta) data managed?** Our prototype system centralises (meta) data stores within shared memory. This simplifies the data exchange implementation itself, such that our article can focus on the main concern of our contribution: (regulating) the interactions between the agents. For example, it trivialises the (de)serialisation of inter-agent communications, and the collection of diagnostic information during experiments, *e.g.*, we can easily inspect entire system snapshots to compare the views of different agents. Realistic data exchange system implementations would instead require physically distributed stores of (meta) data, which requires further design decisions (*e.g.*, how are agreements synchronised?) which we leave out of scope. In anticipation of future experiments focused on these concerns, our implementation preserves a faithful abstraction of a distributed system. For example, an agent cannot observe a statement it has not created or received from a peer.

Secondly, **how is well-behavedness defined?** Our implementation adopts the view of the JustAct framework: well-behaved agents take only permitted actions, where permission is regulated by agents’ policies. We postpone the rest of the discussion until Section 5, where we define and use the Slick language in particular, and characterise its policies.

Finally, **how is well-behavedness enforced?** As a design tenet, the JustAct framework *defines* permission and well-behavedness orthogonally to their means of enforcement; each agent necessarily has sufficient information to check if any observed action is permitted. However, different enforcement mechanisms affect agent incentives. When misbehaviour is *prevented* (ex-ante enforcement), agents can reason in absolutes about (im)possibility via (im)permissibility, *e.g.*, affording their assessment of the risks of harm incurred by misbehaviour. When misbehaviour is *punished* (ex-post enforcement), it has consequences for agents’ behaviour in the future. We leave these considerations out of scope of this article, and implement an enforcement mechanism that suffices to support our experiments and emphasise the unified view of permission: the prototype data exchange implementation lets agents behave arbitrarily, but logs this behaviour to enable perfect (external) audits after the fact. The trace suffices to recognise and diagnose all misbehaviour. Our prototype is provided with a supplementary tool for performing and visualising these diagnoses. An example of the visualisation is provided in Figure 5. The details of enforcement in the data- and control-planes are discussed in Sections 4.2 and 4.3, respectively.

4.2. The Data Plane. Agents are ultimately motivated to interact with the data plane, where their data is stored and shared. By our shared-memory implementation, the sharing of data between agents is trivial; each agent has a view on the same data store.

Agents’ *read* or *write* (together: *access*) data in the shared data store. The runtime system regulates these events by requiring that each realises an *enacted effect* in the control plane. We define (*enacted*) *effects* precisely in Section 5.3.1 atop the policy language. But here, it suffices to say that agents must contextualise each of their access events by identifying

```

JustAct Prototype Event Inspector - v0.1.0

Event-
1) [JUSTACT] Agent st-antoni-1 stated message "st-antoni-1"
2) [JUSTACT] Agent surf stated message "surf 1"
3) [JUSTACT] Agent consortium stated message "consortium 1"
4) [JUSTACT] Published agreement "consortium 1"
5) [JUSTACT] Advanced to time 1
6) [JUSTACT] Agent amy stated message "amy 1"
7) [JUSTACT] Agent dan stated message "dan 1"
8) [JUSTACT] Agent st-antoni-1 enacted action "st-antoni-1 a" ✓
9) [DATAPLN] Agent st-antoni-1 wrote to variable "(st-antoni-1 patients-2024)"
10) [JUSTACT] Agent surf enacted action "surf a" ✓
11) [DATAPLN] Agent surf wrote to variable "(surf utils) entry-count" ✓
12) [JUSTACT] Agent surf stated message "surf 2"
13) [JUSTACT] Agent st-antoni-1 stated message "st-antoni-1 2"
14) [JUSTACT] Agent st-antoni-1 enacted action "st-antoni-1 b" ✓
15) [DATAPLN] Agent st-antoni-1 read variable "(surf utils) entry-count" ✓
16) [DATAPLN] Agent st-antoni-1 read variable "(st-antoni-1 patients-2024) pat"
17) [DATAPLN] Agent st-antoni-1 wrote to variable "(amy count-patients) num-pa"
18) [JUSTACT] Agent amy stated message "amy 2"
19) [JUSTACT] Agent st-antoni-1 stated message "st-antoni-1 3"
20) [JUSTACT] Agent amy enacted action "amy a" ✓
21) [DATAPLN] Agent amy read variable "(amy count-patients) num-patients" ✓

Event 8
Enacted by: st-antoni-1
Enacted to: <everyone>

Action identifier: st-antoni-1 a
Action actor : st-antoni-1
Action taken at : 1

Basis : consortium 1
Justification : consortium 1 and st-antoni-1

Permission : OK
Effects :
- (st-antoni-1 writes ((st-antoni-1 patients-2024) patients))

Justification truths
(((st-antoni-1 patients-2024) executed) within (st-antoni-1))
(((st-antoni-1 patients-2024) has output patients) within (st-antoni-1))
(((st-antoni-1 patients-2024) involves st-antoni-1) within (consortium 1))
(((st-antoni-1 patients-2024) ready) within (st-antoni-1))
((authorise (st-antoni-1 patients-2024) in (st-antoni-1) by st-antoni-1) w
((st-antoni-1 controls ((st-antoni-1 patients-2024) patients)) within (st-an
((st-antoni-1 drives (st-antoni-1 patients-2024)) within (consortium 1))
((st-antoni-1 patients-2024) executed)
((st-antoni-1 patients-2024) has output patients)
((st-antoni-1 patients-2024) involves st-antoni-1)
((st-antoni-1 patients-2024) ready)
((st-antoni-1 says ((st-antoni-1 patients-2024) executed)) within (consortiu
((st-antoni-1 says ((st-antoni-1 patients-2024) has output patients)) within
((st-antoni-1 says ((st-antoni-1 patients-2024) ready)) within (consortium 1)
((st-antoni-1 says (authorise (st-antoni-1 patients-2024) in (st-antoni-1)

Press Q to quit          Press Esc to close trace          Press Shift+./Tab to switch to list

```

Figure 5: Screenshot from the interactive trace inspector. On the left, a list of all system events (both JustAct/control plane and data plane) is shown, where the right shows a more detailed view of a particular enactment. It includes information on actorship, which statements are included in the justification and whether the policy extracted is valid and what are its effects.

the corresponding action (explicitly), data (explicitly), and affector (implicitly: themselves). Agents are able to perform any access events, but the runtime system logs this behaviour along with its context. The runtime system realises the intended correspondence between access events and enacted effects. After the fact, auditors are able to determine precisely which access events *realise* enacted effects. Section 4.3 follows by detailing the related concerns of the control plane, including the creation and permission of actions.

4.3. The Control Plane. The control plane implements the majority of the concepts of the JustAct framework as straightforwardly as possible. Here, we discuss their implementation *in abstracto*, focusing on the essence of the implementation, before Section 4.3.5 presents the implementation in more detail, as Rust code snippets.

4.3.1. Controlled Gossip of Stated Messages. The statics relating to messages are implemented as data types and (field) projection functions. Each message is a product of a *message identifier* and a *payload*: an arbitrary policy. Each message identifier is a pair of its author and a discriminator: arbitrary facts. In the definition of *author'* is the first of many times we use what we call the “prefix trick” to ensure there exists a functional projection of type $X \rightarrow Y$; we let $X \triangleq Y \times Z$ for some discriminator Z , and project X to its first element.

Definition 4.1 (Message Identifiers). $messageIds \triangleq facts \times facts$.

Definition 4.2 (Messages). $messages \triangleq messageIds \times policies$.

Definition 4.3 (Payloads). $\text{payload}(\langle i, p \rangle : \text{messages}) \triangleq p$.

Definition 4.4 (Author). $\text{author}(\langle i, p \rangle : \text{messages}) \triangleq \text{author}'(i)$
 where $\text{author}'(\langle f, f' \rangle : \text{messageIds}) \triangleq f$.

The dynamic creation and communication of statements is implemented as a store of stated messages. Conceptually, we reason about the messages that have been *sent* by which sender. Thus we can precisely characterise *gossip*, where agents can repeatedly send the same messages (*e.g.*, to new recipients). In real distributed systems, gossip is a flexible and scalable means of disseminating non-critical information. Crucially, the sender of a message is distinct from its *author*, which is evident in the message itself.

Definition 4.5 (Sent Messages). $\text{sent} \triangleq \text{agent} \times \text{messages}$.

Definition 4.6 (Statements). $\text{statements} \triangleq \{m \mid \forall \langle a, m \rangle \in \text{sent}\}$.

The runtime controls the gossip of statements to preserve their intended interpretations. Property 4.1 ensures that all sent messages are (at least) sent by their authors. Hence, gossiped statements necessarily originates at their authors, and thus, express the authors' subjective assertions. Property 4.2 identifies payloads via message identifiers. This lets agents define policies that refer to (other) policies. For example, near the end of Section 6.2, *authorisations* are made applicable only if only (payloads of) the given messages define the given *tasks*. The preservation of both properties is simple in the implementation, because the view of each agent is managed by the runtime system; it suffices to check which messages the sender has previously received (for Property 4.1) and sent (for Property 4.2).

Property 4.1 (Message Provenance). $\forall \langle a, m \rangle \in \text{sent}, \langle \text{author}(m), m \rangle \in \text{sent}$.

Property 4.2 (Identifiable Payloads). $\forall \langle i, p \rangle, \langle i', p' \rangle \in \text{statements}, i = i' \rightarrow p = p'$.

4.3.2. *Controlled Gossip of Taken Actions.* The JustAct concept of **action** is implemented similarly to that of statements. The static component of actions are a composite data type, the composition of their actors, justifications, and basis agreements. The dynamic component concerns the gossip of (taken) actions. As with statements, agents' requests to act are regulated to preserve provenance; agents can gossip about other agents' actions, but agents cannot *create* new actions on another actor's behalf.

Unlike statements, the creation of new actions is regulated. The runtime system enforces that only *permitted* actions are taken: after the fact, an auditor is able to evaluate the meta data in the system trace, and check which actions were permitted when they were created. Figure 5 demonstrates such an audit, confirming that the action under inspection indeed satisfies all four conditions of permission (see Definition 3.3).

4.3.3. *Synchronous Time and Agreement Updates.* To preserve Property 3.3, the runtime system specialises the handling of changes to *asynchronous* and *synchronous* control meta data. Two kinds of changes to synchronous meta data are possible: (1) the current time is changed to the given time, and (2) the given agreement is added. These changes have wide-reaching consequences for which actions are permissible. Hence, they are carefully regulated, and are intended to be used sparingly. For the sake of the experiments, we simply vest the power to make synchronous changes in a particular agent. We call this agent *consortium*, to reflect its role in expressing the consensus of all agents.

```

self.handler
// Wait for the fact
// `(surf utils) ready.`
// publish `amy 1`.
.on_truth(
  slick::parse::ground_atom(
    "(surf utils) ready"
  ),
  |view| view.stated.add(
    Recipient::All,
    create_message(1, "amy", r#"
(amy count-patients)
  has input ((surf utils) entry-count).
(amy count-patients) has input
  ((st-antonius patients-2024) patients).
(amy count-patients)
  has output num-patients.
(amy count-patients) ready.">#)
  )
)
// Wait for the action `st-antonius b`,
// publish `amy 2`.
.on_enacted(
  ("st-antonius", 'b'),
  |view, _| view.stated.add(
    Recipient::All,
    create_message(2, "amy", r#"
(amy end) has input
  ((amy count-patients) num-patients).
(amy end) ready.
(amy end) executed.">#)
  )
)
// Wait for agreement and selected
// statements, publish `amy a`
.on_agreed_and_stated(
  ("consortium", 1),
  [
    ("amy", 1), ("amy", 2),
    ("st-antonius", 1),
    ("st-antonius", 2),
    ("st-antonius", 3), ("surf", 1),
  ],
  |view, agree, just| {
    view.enacted.add(
      Recipient::All,
      create_action(
        'a', "amy",
        agree, just
      )
    );
    self.store.read(
      (
        ("amy", "count-patients"),
        "num-patients"
      ),
      ("amy", 'a')
    );
    Ok(()
  )?
  ).finish()
}

```

Listing 1: An example script of an agent’s behaviour, embedded in Rust, but simplified for readability. The script demonstrates stateful reasoning, reacting to an agreement in the control plane by taking action. This script defines the behaviour of agent Amy in Section 6.3.1.

4.3.4. *Scripted Agent Behaviour.* Each agent interfaces with the control plane via a dedicated, bidirectional communication channel: agents send requests to state messages and take actions, and agents receive asynchronous gossip from their peers, and can read the synchronised control data, for example, to check the current time.

For the sake of the reproducibility of our experiments, we implement a simple agent-scripting layer: the behaviour of each agent is fixed by an event-handler, defining how the agent reacts to environmental events by stating messages and taking actions. For example, an agent can be scripted to react to the statement of a given message, a given fact becoming true in any known statement, a given action becoming permitted, and so on. Thus, our accompanying artefact includes a suite of unit tests which lets users reproduce and inspect each of our case study scenarios in Section 6.3. Precisely, our agent scripting language is embedded in Rust, atop the runtime implementation itself. Listing 1 shows an example script (which specifies Amy’s behaviour to be discussed in Section 6.3.1) which embeds policies (expressed in the Slick language to be discussed in Section 5). Amy’s behaviour is expressed as an event handler constructed from a sequence of condition-guarded reactions

```

trait Message {
    type Id;
    type Payload;
    fn id(&self) -> &Self::Id;
    fn payload(&self) -> &Self::Payload;
}
struct MessageSet<M: Message> {
    msgs: HashMap<M::Id, M>
}
trait Timestamp: Eq + Ord {}
trait Action {
    type Message: Message;
    type Timestamp: Timestamp;
    fn basis(&self) -> Agreement<
        Self::Message,
        Self::Timestamp
    >;
    fn justification(&self)
        -> MessageSet<Self::Message>;
}
struct Agreement<M: Message, T: Timestamp>
    { message: M, timestamp: T }

trait Set<E> {
    fn contains(&self, elem: &E) -> bool;
    fn iter(&self)
        -> impl Iterator<Item = &E>;
}
// Encodes centralized mutability
trait SetSync<E>: Set<E> {
    fn add(&mut self, elem: E);
}
enum Selector { All, Agent(String) }
// Encodes distributed mutability
trait SetAsync<E>: Set<E> {
    fn add(
        &mut self,
        target: Selector,
        elem: E
    );
}

trait Times: Set<Self::Timestamp> {
    type Subset: Set<Self::Timestamp>;
    type Timestamp: Timestamp;
    fn current(&self) -> Self::Subset;
}
trait TimesSync: SetSync<Self::Timestamp>{
    fn add_current(
        &mut self,
        timestamp: Self::Timestamp
    );
}

trait Agent {
    fn id(&self) -> &str;
    fn poll<ME, AC, TS, ST, EN, AG, TI>
        (&mut self, view: (ST, EN, AG, TI))
    where
        ME: Message,
        AC: Action<Message = ME,
            Timestamp = TS>,
        TS: Timestamp,
        ST: SetAsync<ME>,
        EN: SetAsync<AC>,
        AG: Set<Agreement<ME, TS>>,
        TI: Times<Timestamp = TS>;
}
trait Synchronizer {
    fn poll<ME, AC, TS, ST, EN, AG, TI>
        (&mut self, view: (ST, EN, AG, TI))
        -> ControlFlow;
    where
        AG: SetSync<Agreement<ME, TS>>,
        TI: TimesSync<Timestamp = TS>,
        /* Rest is same as for agents */;
}

```

Listing 2: Simplified Rust source code showing a part of the control plane’s generic ontology.

to the environment. For example, Amy reacts to the observation of a statement in which (surf utils) ready is true by stating her own message which is identified by amy 1.

We expect realistic systems to automate the behaviour of some agents in a similar fashion. In general, the details of the automation are subject to a large design space. For example, scripts that await given messages are less costly to execute, while scripts that evaluate the denotations of statements are more flexible and expressive. The most intelligent agents must formulate and solve complex search problems over statements and actions.

4.3.5. *Overview of the Implementation.* The prototype runtime system is implemented in Rust, and the implementation of its control plane is structured to reflect the structure of the

article: the Rust embedding of the JustAct framework (in general) is loosely coupled to its particular implementation in our prototype data exchange runtime system (in particular).

First, Listing 2 shows a simplified version of the *ontology* library, encoding the JustAct framework as Rust traits. It specifies the capabilities of information exchanged between agents (message(set)s, actions, timestamps and agreements) and of sets storing that information (stated, enacted, times and agreed). An abstraction of agents and entities capable of synchronization is given to be able to interchange them between specific runtimes.

Second, Listing 3 implements the traits comprising the ontology, *i.e.*, instantiating the corresponding concepts of the JustAct framework. For example, for simplicity (and efficiency), the following implementation passes control information within shared memory, rather than (de)deserialising and passing it over the network. The distributed system is simulated by each agent having its own *view* of the control plane as a subset of the statements and actions. Both the global and local views on statements and actions are implemented as *grow-only sets*, which are *contention-free replicated data types (CRDT)*, which are suited for adaptation to implementations in which agents are physically distributed [ASB15]. Note that the implementations of the traits are orthogonal to the implementation of agent behaviour: that is still done over the interfaces only, showing that agents can reason at the level of the framework instead of the underlying implementation details.

Finally, Listing 4 brings the implemented structs together by orchestrating the agents and their views on the system. The implementation of the runtime system becomes sufficiently complete for compilation once it is (statically) instantiated with a particular policy language.

5. THE SLICK POLICY LANGUAGE & INTERPRETER

We use *policy language* to refer to a set of definitions of JustAct concepts concerning policies. The definition of `policy` captures the syntax of the language. The definitions of `truth` (via `fact`, `in`, and `of`) and `valid` capture orthogonal semantic notions of policies. Hence, Sections 4 and 5 together complete a particular instantiation of the JustAct framework.

5.1. Design Considerations. The framework imposes several essential requirements on the policy language. The most essential requirement is expressed in Figure 2 itself: truth must be a static relation over facts and policies. In practice, this means that the truth of a given fact in a given policy must be computable via a deterministic and terminating procedure. This requirement underpins the purpose of the same policies to be consistently understood by different agents, or at different times. For example, (complete) Prolog is an unsuitable policy language, because its inference procedure is non-terminating. Even if agents agree on a Prolog program, their conclusions are not consistently reproduced. Consider a case where Amy justifies the processing of Bob’s medical data with a Prolog policy which Amy successfully validated. Three hours later, an auditor checks the justification, but their evaluation of the Prolog policy times out. The auditor cannot distinguish between an invalid policy and a policy that Amy intentionally crafted to time out. Should Amy be punished for acting? In such an environment, would Amy risk acting in the first place?

```

struct MessageData {
    id: (String, u32),
    payload: Policy,
}
impl justact::Message for MessageData {
    type Id = (String, u32);
    type Payload = Policy;
    fn id(&self) -> &Self::Id { &self.id }
    fn payload(&self) -> &Self::Payload {
        &self.payload
    }
}

impl justact::Timestamp for u64 {}

struct ActionData {
    basis: Agreement<MessageData, u64>,
    justification: MessageSet<MessageData>,
}
impl Action for ActionData {
    /* akin to MessageData */
}

struct AsyncSet<E> {
    data: HashMap<String, HashSet<E>>
}
impl<E> AsyncSet<E> {
    // Returns the view of agent `id`
    fn scope(&mut self, id: String)
        -> AsyncSetView<E> {
        AsyncSetView { set: self, id }
    }
}

struct AsyncSetView<E> {
    set: &mut AsyncSet<E>,
    agent: String,
}
impl<E> Set<E> for AsyncSetView<E> {
    fn contains(&self, elem: &E) -> bool {
        self.set.data.get(&self.agent)
            .contains(elem)
    }
    fn iter(&self)
        -> impl Iterator<Item = &E> {
        self.set.data.get(&self.agent)
            .iter()
    }
}

impl<E> SetAsync<E> for AsyncSetView<E> {
    fn add(
        &mut self,
        selector: Selector,
        elem: E
    ) { match selector {
        Selector::All => {
            for view in &mut self.set.data {
                view.insert(elem.clone());
            }
        },
        Selector::Agent(agent) => {
            self.set.data.get_mut(&agent)
                .insert(elem)
        }
    } }
}

struct TimesSet {
    all: HashSet<u64>,
    current: Option<u64>,
}
impl Set<u64> for TimesSet {
    /* maps to `self.all` */
}
impl SetSync<u64> for TimesSet {
    /* maps to `self.all` */
}
impl Times for TimesSet {
    type Subset = Option<u64>;
    type Timestamp = u64;
    fn current(&self) -> Self::Subset {
        self.current
    }
}
impl TimesSync for TimesSet {
    fn add_current(
        &mut self,
        timestamp: Self::Timestamp
    ) {
        self.current = Some(timestamp);
    }
}

```

Listing 3: Simplified Rust source code showing a part of the control plane’s specific instantiation.

5.2. The Slick Language. For our experiments, we use a bespoke policy language that we refer to as *Slick*. It is based on Datalog[−], so its fundamentals remain similar: each program consists of a sequence of rules (but whose ordering is irrelevant to the semantics) whose antecedents are possibly negated. For each policy, the semantics prescribes Boolean truth to a finite subset of the infinite syntactic category of ground (*i.e.*, variable-free) facts. We complete the description of Slick by enumerating its differences from Datalog[−]; observe that each difference is either superficial or based on well-established research:

```

fn game_loop(
  agents: Vec<dyn Agent>,
  sync: Box<dyn Synchronizer>
) {
  let st = AsyncSet::<Message>::new();
  let en = AsyncSet::<Action>::new();
  let ti = TimesSet::new();
  let ag =
    HashSet::<Agreement<Message, u64>>
      ::new();

  loop {
    for agent in &mut agents {
      agent.poll((
        &mut st.scope(agent.id()),
        &mut en.scope(agent.id()),
        &ag,
        &ti,
      ));
    }

    match sync.poll((
      &mut st.scope("environment"),
      &mut en.scope("environment"),
      &mut ag,
      &mut ti,
    )) {
      {
        ControlFlow::Continue => continue,
        ControlFlow::Break => break,
      } } }
}

```

Listing 4: Simplified Rust source code showing the “game loop” of the system, orchestrating the agents and managing their access to state.

- (1) Slick departs from the traditional **concrete syntax** of Datalog[⊥] to (in our opinion) aid in the readability of long rules. We conjoin atoms with `and` and arguments of atoms with white space (both instead of `(,)`) and we separate consequents from antecedents by `if` instead of `(:-)`. The use of `not` is unchanged, as it already suits the new style.
- (2) **Inference** uses the operational form [Prz90] of the *well-founded semantics for general logic programming with negation* [VGRS91]; a value in $\{true, false, unknown\}$ is deterministically assigned to every conceivable policy. Notably, the semantics robustly preserves meaning even in cases that many alternative semantics (*e.g.*, the stable model semantics) collapses. Also notably, the majority of cases (*e.g.*, all policies examined in this article), the two semantics coincide anyway. For the purposes of JustAct, it suffices to conflate *unknown* and *false* valuations of facts: neither is true. For example, `p if not p` formalises a logical contradiction, giving `p` unknown value; agents agree that `p` is not true.
- (3) **Facts** are inductively defined. As in Datalog[⊥], facts may be constructed by applying a constant predicate symbol to a list of constants or variables. However, unlike Datalog[⊥], (sub)facts may occur wherever variables may occur, and variables quantify over *ground facts*, and not only constant symbols. In database and logic programming literature, this feature is well-studied, and is usually called *function symbols* [Llo84, RU95, CGMT15, GMT13]. The syntax of rules are generalised accordingly; consequents and antecedents are facts that are possibly composed from smaller facts. Variables may occur in facts at any depth. Naturally, the semantics is generalised to handle these composite facts. This generalisation lets Slick policies more easily model various other forms of policy, for example, policies expressed in eFLINT via nested eFLINT fact-instances. In general, this feature affords the more terse and intuitive definition of policies which are comparatively cumbersome and un-intuitive when expressed in Datalog[⊥]. For example, consider how the Slick rule `some vote if Agent votes` is applicable regardless of the internal structure of the fact binding the variable `Agent`, which would otherwise require a unique Datalog[⊥] rule specialised to each shape of Datalog[⊥] fact to be bound by `Agent`.
- (4) **Fact arguments are homogenous** and parenthesis are only needed to avoid structural ambiguity. For example, `eats(amy, apples)` in Datalog[⊥] can be translated into Slick as

`amy eats apples`, which is read very naturally. Firstly, because predicates are constants like any other, they can be abstracted by variables; consider how, in the prior example, only in Slick could constant `eats` be abstracted, *e.g.*, by variable `Uses`. Secondly, note how this reduces the visual complexity of rules, because one layer of parenthesis is avoided.

- (5) Slick supports **(in)equality constraints** over (all pairs in sets of) facts as antecedents, using keywords `same` and `diff`. This is a well-studied feature of logic programming languages, *e.g.*, described in [GM84]. In practice, it can tersely capture common patterns in agreements, where the applicability of key rules is conditioned on particular facts (mis)matching. For example, `error if X authorises and not same { X amy }` is applicable if `X` binds `bob`, but not if `X` binds `amy`. Note `not same { X Y Z }` and `diff { X Y Z }` have different meanings; only the former is satisfied in the case where $x = y \neq z$.
- (6) As we have described it thus far (“ideal Slick”), the inference procedure underlying the Slick semantics is non-terminating. For example, consider attempting to finish enumerating the truths of `Fact is true if Fact. it is raining.` Unfortunately, ideal Slick belongs to the large subset of conceivable logic programming languages for which checking termination is undecidable. The space of workarounds and compromises has been thoroughly researched for many years [SD94]. As this is not the focus of this work, we opt for a pragmatic approach to ensuring that inference terminates: we **bound the maximum depth of true facts** to a statically-configured parameter, as in [Cho95]. However, where [Cho95] ignores facts deeper than the bound, we instead detect and make explicit when the bound is exceeded: each such policy is trivialised and invalidated; precisely, its denotation is replaced by that of the policy `error. bound exceeded`. Thus, for all policies, (a) with enough computational resources³, queries are eventually answered, and (b) validity guarantees that each logical implication encoded by each rule is satisfied by its truths.
- (7) We define validity as for Datalog[⊃] in Section 3.1: policy p is valid unless the fact `error` is true in p . Other than this special meaning, `error` is an entirely ordinary fact. Section 6.3 demonstrates, and Section 7 discusses, how Slick affords agents’ *cooperative specification* of shared policies, via its *composition control* language features [EvB24]. In summary, agents agree that only *valid* justifications are useful, where validity captures requirements of the contributors to the policy, including requirements on the runtime context of the contributions themselves. Note that, by using features 3 and 4, we can introduce a degree of explainability by deriving verbose `error`-facts that refer to the rule deriving them; *e.g.*, the program `error (b was true) if b. error if error X.` will implement validity as expected while the model of the program provides additional information why it is invalid.

The following presents the Datalog[⊃] rules shown in Table 1 translated into Slick. Note how Slick rules easily reproduce Datalog[⊃] rules one-to-one, differing only in the concrete syntax.

```
error if      amy confirms.  amy confirms if amy trusts X.
error if not amy confirms.  amy trusts bob.
bob deletes data1.
```

5.3. Connecting Policies to the Runtime System. We complete the instantiation of the JustAct framework by defining the remaining concepts in Figure 2. These final concepts

³Slick affords additional constraints to further restrict valid policies to the benefit of bounding the resources needed for reasoning. For example, one can limit the number of truths before the policy is invalidated.

inter-connect the policy language (in Section 5, currently) with the rest of the runtime system (in Section 4, previously).

5.3.1. *Defining Effects and Affectors.* Effects connect the (output of) the policy reasoning process to the behaviour of agents in the data exchange system: agents realise the effects of (justifications of) actions as the reading and writing of data in the data plane.

Recall from Figure 2 that effects themselves are a static concept: they are a subset of *truths* that statically identify their *affector* agents. We let each truth of a fact matching `Agent reads Data` or `Agent writes Data` be effects, and let their affectors be `Agent`. Hence, without any runtime context, it is evident that the policy `amy reads data1. amy is happy.` has two truths, but only the effect `amy reads data1`, whose affector is `amy`. An effect is connected to a particular action, at runtime, when the effect is *enacted* (Definition 3.4). Agents can *realise* these effects by influencing the data plane in the corresponding manner. For example, once the effect `amy reads data1` is enacted, it can be realised by Amy reading the data identified by `data1`.

Because effects are the interface between the control- and data-plane, any definition of effects ultimately determines the granularity at which policies can regulate the data plane. By our definition, each effect identifies its affector and the data, but notably, it does not identify the *contents* of the data. Consequently, in this article, policies cannot distinguish the contents written or read by agents in the data plane.

5.3.2. *Reflecting Policy Context via Extract.* Finally, *message set `extract` policy* yields the policy contents of any given (set of) messages: the input to the policy reasoning process. As was done in Datalog⁺ in Section 3.1, our definition is such that the policy extracted from an individual message `Msg` reflects its runtime context. This is implemented in Rust as a function with the type signature `fn extract_from(payload: Policy, msg_id: GroundAtom) -> Policy`. Precisely, the result is a syntactic transformation of the arbitrary *payload*: for each rule, each existing consequent `Fact` is supplemented by the consequent `Fact within Msg`. Intuitively, messages can assert any truths, but not without tracing back to the message identifier (and the author). As in Section 3.1, *extract* is applicable to non-singleton message sets also, in which case the result is the composition of the policies extracted from each message independently. Finally, in the context of (the justification of) an action by actor `Agent`, the extracted policy undergoes a second syntactic transformation: the rule `actor Agent` is added.

Agents rely on *extract* to reflect the runtime context of a message in (a transformed version of) its payload. Notably, truths of the form `Fact within (Author M)` trace the truth of `Fact` to the message `Author M` authored by `Author`. In Section 6, to follow, these features let the usual rules of Slick specify the powers of agents to make statements and take actions, or to (conditionally) *delegate* these powers to other agents. But for now, we demonstrate with a more familiar example: the Slick rules below encode the *ownership* mechanism, defined in natural language in Section 3.1, regulating the authorship of the rules above. Consequently, for example, rules asserting `amy confirms` are invalid unless they are authored by `amy`.

```
error if      (amy confirms) within (Author M) and diff { Author amy }.
error if      (amy trusts X)  within (Author M) and diff { Author bob }.
error if (bob deletes data1) within (Author M) and diff { Author bob }.
```

```

type Policy = Vec<Rule>;
struct Rule {
  consequents: Vec<Atom>,
  pos_antecedents: Vec<Atom>,
  neg_antecedents: Vec<Atom>,
  checks: Vec<Check>,
}

struct Check {
  atoms: Vec<Atom>,
  kind: CheckKind,
  positive: bool,
}
enum CheckKind { Diff, Same }

enum Atom {
  Constant(Text),
  Tuple(Vec<Atom>),
  Variable(Text),
}

enum GroundAtom {
  Constant(Text),
  Tuple(Vec<GroundAtom>),
}

impl Policy {
  fn parse(text: &str) -> Option<Self>;
  fn denotes(self) -> Option<Denotation>;
}

struct Denotation {
  trues: Vec<GroundAtom>,
  unknowns: Vec<GroundAtom>,
}

impl Denotation {
  fn is_valid(&self) -> bool;
}

```

Listing 5: Simplified Rust source code of the Slick parser and interpreter.

5.4. The Slick Interpreter Implementation. The Slick interpreter interprets the Slick language, as it is described in Section 5.2, yielding its *denotation*: a valuable of each fact. Hence, the denotation of each p also reflects the validity of p : is `error` true in p ?

The work of the interpreter can be divided into two stages: *parsing* and *inference*:

- (1) The input is **parsed** into an intermediate representation: a set of message-annotated rules. There are six kinds of antecedent, for the six combinations of the following two choices: (a) positive or negative (`not`), and (b) truth-check, equality-check (`same`), or inequality-check (`diff`). For example, `error if agent A and not same { A amy }` has only consequent `error`, a check that `agent A` is true, and a check that `A` and `amy` are not equal.
- (2) The interpreter implements the **inference** algorithm in [Prz90] as straightforwardly as possible. From the initially empty fact set S_{false} , the inference procedure computes new S_{true} fact set by exhaustively instantiating and applying the given finite rules. In case the depth of a fact exceeds the configured maximum bound, inference restarts with the input policy (`error. bound exceeded.`). Otherwise, the process continues, at each step initialising the next S_{false} as the complement of S_{true} , which can be understood as operationalising “assume everything we failed to prove is false”. Provably, this process continues to an alternating fixed point: S_{true} and S_{false} alternate forevermore. The final truths are S_{true} and the unknowns are $S_{\text{false}} \setminus S_{\text{true}}$. See [Prz90, VGRS91] for more details on the well-founded semantics, and the intuition behind the alternating fixpoint.

The Slick interpreter is implemented as a Rust library. Listing 5 shows the library’s API, *i.e.*, the `Policy` data type and its methods; users parse policies from text and then compose and inspect their denotations.

6. CASE STUDY: PROCESSING DISTRIBUTED MEDICAL DATA

In this section, we demonstrate and evaluate the JustAct framework (Section 3), instantiated as a data exchange runtime system (Section 4) with the Slick policy language (Section 5), and then applied to policy-regulated medical data processing across institutional domain

boundaries. Section 6.1 overviews the subject of our case study: the BRANE component of the EPI framework. Section 6.2 (re)presents BRANE through the lens of the JustAct framework, and initialises our runtime system (instantiating JustAct) and then Section 6.3 walks through its dynamic behaviour in application to five representative usage scenarios. Finally, Section 6.4 evaluates the characteristics of our runtime system in application to BRANE’s usage scenarios, drawing particular attention to the role of the JustAct framework.

6.1. The Case: The BRANE Component of the EPI Framework. The *Enabling Personalised Interventions* (EPI)⁴ project aimed to create digital twins in healthcare to improve patient treatment prediction [KAA⁺24]. Research on EPI investigated the challenges of safely coordinating the federated processing of medical data across organisational boundaries within the European Union, *e.g.*, between hospitals, universities, and research centres.

An overarching technical contribution of the EPI project is the *EPI Framework*, which is conceptualised as a modular suite of software components that work together to control and automate facets of data-processing pipelines [KdLTG20, KME⁺24]. The most complete and recent overview of the EPI framework is given in [KME⁺24]. Various articles report on the development of its specialised components. For example, [KVBG21] (re)routes network messages between containerised functions to the satisfaction of security constraints.

In this work, we focus on BRANE, the component responsible for unfolding users’ processing workflows by planning, orchestrating, and coordinating the execution of workflow tasks. Workflow tasks are executed by *worker* services and have the effect of computing new data from existing data. Workers and data-related assets are distributed over physical machines and (technical approximations of) *organisational domains* [VCB21]. For example, a hospital is a domain that provides and controls some medical datasets.

[EMvBB22] focuses on the regulatory facet of BRANE: each domain is represented by a *checker* service that reasons about and enforces the domain’s *policies*, asserting control over the usage of the assets provided by the domain. For example, via the checker, a human policy expert defines the hospital’s policy, which expresses constraints on the permitted processing of the hospital’s medical records in order to protect the privacy of patients. In this context, an extra complication is that domain-local policies express decisions in terms of *meta* data that may also be sensitive, *e.g.*, “the processing of data-asset `foot-fracture-x-rays1.png` requires the consent of Amy” reveals sensitive information about Amy. [EMvBB22] addresses this complication by prescribing a policy-worker interface that gives domains maximal control over the extent to which private policy information is publicised via their policy decisions. Precisely, the execution of planned execution steps await concrete *authorisations* from the involved domains, just in time. Hence, domains control the usage of their data, and they also decide how to balance policy privacy against system productivity.

Below, we clarify the usage of BRANE by enumerating the kinds of its constituent services and overview their roles and interactions. They are listed in an order that suggests the progression of a successful workflow execution from top to bottom:

- (1) A **driver** defines computational workflows: directed acyclic diagrams expressing the functional dependencies. Each result (data) depends on a containerised function (data) and arguments (data). The driver reads their workflow’s results once they are available.
- (2) The **planner** *plans* workflows, assigning workflow tasks to workers for execution.

⁴<https://enablingpersonalizedinterventions.nl>

- (3) A **checker** *authorises* workflow plans whose execution (and the necessary reading and writing of data by workers) conforms to the checker’s local policies.
- (4) A **worker** executes their assigned workflow tasks which have sufficient authorisations. The worker reads the function and argument data, then computes and writes the result.

Of the above services, only the planner is generally centralised, ultimately orchestrating the other services’ tasks by planning the assignment of tasks to workers. Each organisational domain hosts drivers, checkers, and workers, which participate in data processing and regulation. In principle, any subset of services may be automated, but in general, drivers and checkers are intended to interface BRANE with data scientists (defining work to be executed) and policy experts (regulating data access via workflow execution), respectively.

6.2. Initialising our Runtime System for BRANE Scenarios. Figure 6 visualises the refinement of our runtime system such that BRANE concepts are mapped to elements of our runtime system. First and foremost, we map BRANE’s notion of (organisational) *domain* to our notion of *agent*, such that distinct domains are distinct agents. This determines the granularity at which control is distributed, and at which the autonomous entities are distinguished. Hence, each agent can *play the role of* several of BRANE’s services. For simplicity, this abstracts away the internal organisation of each domain. For example, we do not consider contention over several human users’ and several services’ to make statements and take action as agent `st-antoni`, which represents the organisational domain of the St. Antonius hospital. Throughout this section, we use St. Antonius (a Dutch hospital) and SURF (a Dutch research institute) as examples of domains. These organisations are real contributors to the EPI project. Our example users (Amy, Bob, and Dan) are fictitious.

In Sections 6.2.1 and 6.2.2, to follow, we complete the mapping of BRANE concepts to facets isolated to the data and control planes, respectively.

6.2.1. The BRANE Data Plane. Our runtime system and BRANE rely on a similar abstraction of a shared (initially empty) data store, whose data is read and written by the agents.

Agents’ access to data in the data plane is regulated via the connection to enacted effects, as specified previously in Section 6.2.1. Any agent `Agent` can introduce fresh data `Data` using the existing mechanism of executing workflow tasks: it suffices for `Agent` to define a fresh workflow (playing the role of driver) with no inputs and the output `Data`, and executing the task (playing the role of worker). In the next section, we design the policies such `Agent` is always permitted to enact the above, and it has the desired effect: `Agent writes Data`.

6.2.2. The BRANE Control Plane. In the initialisation of the control plane of our runtime system, we reproduce BRANE’s tracking and control of agents, assets, workflows, and so on.

In the original BRANE, system properties are defined in publications such as [KME⁺24], for users to reason about. However, naturally, there is a gap between these concepts and their encoding in the BRANE implementation, which are ultimately enforced at runtime. For example, [KME⁺24] uses precise wording and logical notation to define the obligation of workers to observe authorisations from involved checkers.

Instead, in our version of BRANE, we express these properties in stated and agreed policies in order to narrow the gap between their definitions and their implementations. In the remainder of Section 6.2.2, we define and explain the *initial agreement*, which is stated by `consortium` as the runtime system is initialised. This consortium agent corresponds to no

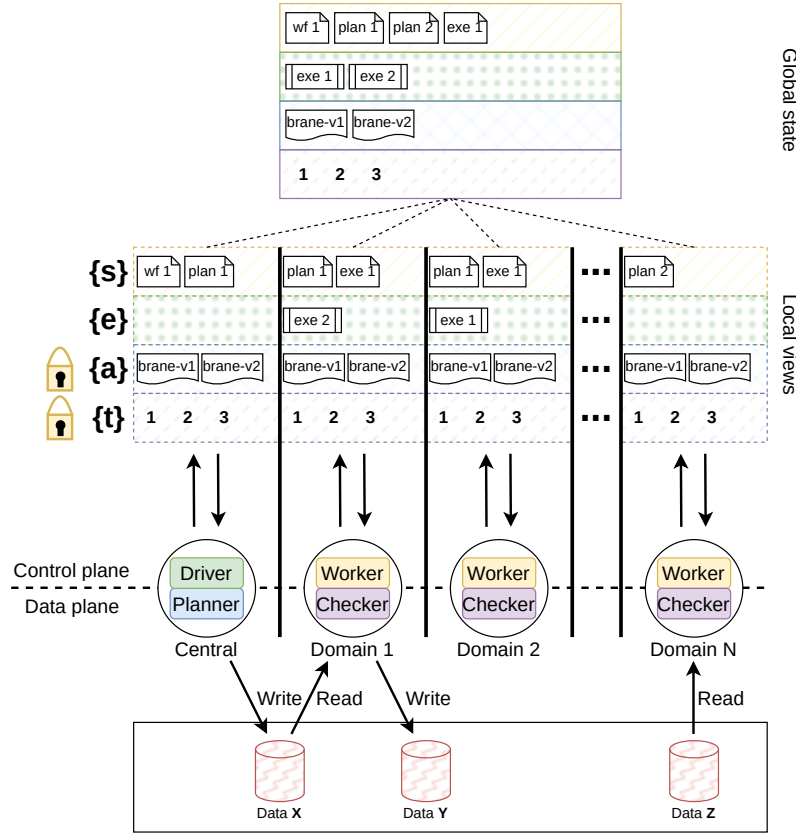

Figure 6: Graphical depiction of our runtime system instantiated for application to BRANE usage scenarios. Hence, this figure refines Figure 4: BRANE services map to our agents, and (the distinct kinds of) BRANE control meta data are mapped to meta data in our control plane. BRANE’s medical data maps trivially to our data plane.

particular physical entity or human user at runtime. Instead, it represents the consensus of the other agents; its only purpose is to state the content of the agreements.

Figure 7 gives an ontological view of the initial agreement. This view is intended to guide the reader’s interpretation of the agreement itself; *e.g.*, the figure emphasises the need for each *task* to have exactly one *driver* agent. Ontological sets are encoded in the agreement itself as facts matching structural patterns, *e.g.*, *inputs* are encoded as facts matching `Task has input Variable`. Ontological functions are encoded either structurally, *e.g.*, a sub-fact of each *input* is a *task*, or they are encoded in truth via rules, *e.g.*, `ready \Leftarrow executed` is encoded as `error if Task executed and not Task ready`. The initial agreement layers additional meaning atop the ontology. Notably, via rules conditioning invalidity, it specifies the inter-agent power dynamics. For example, only the driver of a task may define its inputs.

The following snippet shows the first part of the initial agreement, which creates and protects basic abstractions that truths are intended to provide over the runtime context of policies. Recall that the policy extracted from a message is a transformation of its payload that asserts the following two kinds of property: (1) if a rule within message `Msg` has consequent `Fact`, then it also has consequent `Fact within Msg`, and (2) in the context of an action with actor `Agent`, rule actor `Agent` is added. The first two rules of the agreement, respectively,

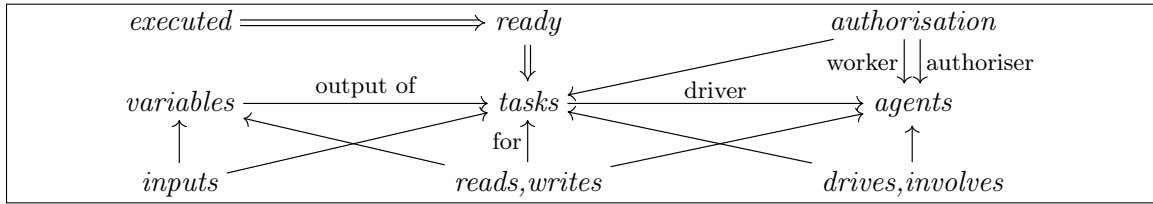

Figure 7: Graphical ontology of the initial agreement of our reproduced BRANE system. Sets (italicised) are related by pure, total functions (\rightarrow and \Rightarrow arrows) from domain to co-domain. Each (\Rightarrow) denotes an identity function, *e.g.*, $ready \subseteq tasks$.

preserve the converse properties, *i.e.*, preventing (the authors of) statements from mimicking the reflection mechanism with their own rules. This immediately demonstrates our first of many usages of Slick’s *composition control features* [EvB24]; Slick rules specify which other rules may be included, as a function of their runtime context. The other two rules then create and likewise protect a new abstraction: each truth of the form `Sayer says Fact` reflects the author of the rule inferring `Fact`. This relies on Definition 4.1: each message identifier matches `Author X`, where `Author` identifies the message author.

Note the condition `diff { (consortium 1) (Sayer M) }`; this gives special status to the rules within the initial agreement, for one reason, to avoid the inference of infinitely large facts of the form `consortium says (consortium says (...))`. In the remainder of the initial agreement, rules of the form `error if Agent says (...)` are included to protect many such abstractions.

```
// Statement (consortium 1) ...
error if (Fact within Msg1) within Msg2.
error if (actor Agent) within Msg2.

Sayer says Fact if Fact within (Sayer M) and diff { (consortium 1) (Sayer M) }.
error if Sayer says (Agent says Fact).
```

The remaining parts of the initial agreement concern more the concrete facets of BRANE. The next part characterises *drivers* as agents that (1) define the input-output dependencies of *tasks* on data, and (2) mark tasks as ready for execution. For example, a user defines a workflow via a typical scripting language (*e.g.*, BraneScript, typically used with BRANE [VCB21]), including the assignment statement $y := f(x)$. The corresponding driver encodes this as a fresh task `t` by stating `t has input (t f)`. `t has input (t x)`. `t has output y`.

Figure 7 visualises the need for each task to have a unique driver as the function arrow `tasks driver agents`. As in Definition 4.1, we use the “prefix trick” to encode this requirement in the initial agreement: each task is a *driver-name* pair, where names discriminate the tasks with the same driver; *i.e.*, we use drivers as task namespaces. Hence, we reduce the (complex) problem of disambiguating the driver of a task to the (simple) problem of naming tasks. This problem is simple in BRANE, as drivers already have distinct identifiers.

The first four rules introduce and protect the abstraction of agents that behave as drivers. The final rule ensures that only the driver identified by the task drives the task.

```
// ... continuing statement (consortium 1) ...
Sayer drives Task if Sayer says (Task ready).
Sayer drives Task if Sayer says (Task has input Variable).
Sayer drives Task if Sayer says (Task has output Label).
error if Sayer says (Agent drives Task).
error if Agent drives (Driver Name) and diff { Agent Driver }.
```

The next part prevents the premature execution of tasks. Precisely, tasks cannot be executed until they are ready, and the tasks producing their inputs are also executed.

```
// ... continuing statement (consortium 1) ...
error if Task executed and not Task ready.
error if Task2 executed and Task2 has input (Task1 Label) and not Task1 executed.
```

The next part defines the *effects* of enacting the execution of tasks.

We again use the “prefix trick” to translate *variables* output of *tasks* from Figure 7 into the initial agreement: each variable is a task-label pair, where labels discriminate the variables of the same task; *i.e.*, variables globally identify asset data, while labels are task-local.

The first two rules infer the *enacted effects* of actions enacting the execution of a task: the acting worker reads each input, and writes each output as truths matching *Worker reads Variable* and *Worker writes Variable*. The other rules prevent these effects from arising in any other way. Recall from Section 4.2 that the runtime system uses these effects to regulate agents’ access to asset data; agents can only read or write asset data when these are the effects of their (permitted and taken) actions. The scenarios will demonstrate several examples of agents reasoning backward from the effects they desire to the necessary actions and statements.

```
// ... continuing statement (consortium 1) ...
Worker reads Variable if Task has input Variable and actor Worker
                        and Worker says (Task executed).
Worker writes (Task Label) if Task has output Label and actor Worker
                        and Worker says (Task executed).
error if Sayer says (Worker reads Variable).
error if Sayer says (Worker writes Variable).
```

The final part of the initial agreement encodes the roles of checkers in BRANE. In summary, the execution of planned workflow tasks is conditioned on the authorisation of all *involved* agents. We reproduce BRANE’s inductive definition of involvement from [KME⁺24]. In the base case, agents are involved with data they control. In the inductive case, a checker’s involvement propagates over tasks from their outputs to their inputs, in the direction of data flow. Intuitively, checkers are involved with all derivatives of the data under their control. This mechanism gives each involved checker the power to veto the task’s execution by withholding their authorisation, *e.g.*, reflecting their policy decisions without otherwise revealing the domain policies themselves [EMvBB22]. For example, a hospital authorises a particular trusted worker to process their sensitive medical records, but vetos the result being further processed elsewhere by withholding any further authorisations.

The final rule protects authorisers from unintentionally authorising tasks with unexpected inputs. Precisely, agents have a means of asserting that the given message *closes the inputs* (Definition 6.1) of some task *t*; each authorisation is scoped to a particular message, and the policy is invalidated if any other message attributes input variables to the authorised task. Consider how drivers cannot be prevented from defining *t* differently in different statements. However, this rule prevents workers from executing *t* with some input *v* (from one message) as justified by an authorisation without *v* (from another message), unintentionally or otherwise.

Definition 6.1 (Messages *M* close the inputs of task *t*). $closeInputs(M, t) \triangleq$

$$\forall v \in facts, M' \supseteq M, \quad \neg true(extract(M), t \text{ has input } v) \wedge \\ true(extract(M'), t \text{ has input } v) \quad \rightarrow \quad \neg valid(extract(M')).$$

```

// ... completing statement (consortium 1).
error if Worker says (Task executed) and (Task has input Variable) within Msg
    and Task involves Checker and not Checker says (authorise Task in Msg by Worker).

Task involves Checker if Checker controls (Task Label).
Task2 involves Checker if Task2 has input (Task1 Label) and Task1 involves Checker.

error if authorise Task in Msg1 by Worker
    and (Task has input Variable) within Msg2 and diff { Msg1 Msg2 }.

```

The initialisation of the control plane for each BRANE scenario begins with no statements, actions, agreements, at the initial current time of 1. The control state is initialised with `AgentCmd` and `SyncCmd` trait objects which define the input stream from the runtime system’s environment; these capture the system’s interactions with the autonomous agents and their synchronised interventions, respectively; these are detailed for each scenario in Section 6.3. Finally, regardless of the scenario, we then immediately use the usual agent input streams to setup the initial agreement: (1) `consortium` states `consortium 1` and broadcasts it to all agents, and then (2) `consortium 1` is agreed to apply at time 1.

6.3. Usage Scenarios. Here we walk through a sequence of scenarios in which we apply our initialised runtime system to new and existing usage scenarios of BRANE. Note that our discussion of the first scenario is the most detailed, because most of its details are novel.

6.3.1. Existing Usage: Isolated Authorisation and Execution. We demonstrate the application of our system to a representative usage of the original BRANE system: several agents cooperate to drive the execution of data-processing workflows, as permitted by agent reasoning in isolation about their local policies. In our scenario, this isolation manifests as truths of the form `authorise Task in Msg by Worker` being stated only as facts, i.e., inferred by variable- and condition-free rules. Effectively, agents entirely externalise their reasoning about local policies, and reveal only the resulting authorisations, on a case-by-case basis.

The scenario begins with the `surf` agent creating fresh data by executing a zero-input task in the statement `surf 1`. The data is bound to the fresh variable `(surf utils) entry-count`, which can be used as input in other workflows.

Figure 8 depicts these, and all (relations between) tasks and variables used in Section 6.3.

```

// Statement (surf 1).
(surf utils) has output entry-count.
(surf utils) ready.
(surf utils) executed.

```

We let ‘Analyst’ Amy drive the completion of a one-task medical data workflow. Amy is a (human) data scientist working to collect basic statistics of European hospitals, starting with the St. Antonius hospital. Amy defines a fresh task with the suggestive name `count-patients`, and marks it ready for execution. Intuitively, it encodes an assignment that would be rendered as $numPatients := entryCount(patients)$ in typical imperative workflow languages. Input variables with labels `entry-count` and `patients` are outputs of tasks driven by `surf` and `st-antoni`, respectively. Amy publicises this statement to her peers.

On its own, `amy 1` defines a task, but does not justify its execution. Formally, there exists no valid subset of existing statements that include `amy 1`. Intuitively, the execution of `st-antoni patients-2024` has no valid justification, but Amy’s task depends on its output.

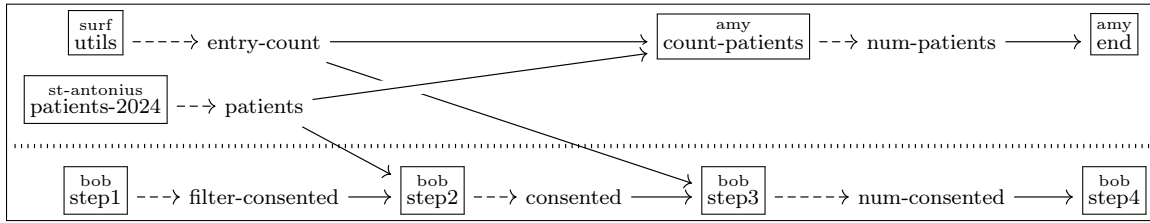

Figure 8: Bipartite graph of workflow tasks (task-names overset by *-drivers* in boxed vertices) and asset variables (variable-labels in unboxed vertices), in scenarios of Section 6.3, related by data-dependencies in the direction of data flow; output (dashed arrows) relates tasks to variables, and input (solid arrows) relates variables to tasks. The dashed line separates tasks defined in Scenarios 1 (above) and 2 (below).

```
// Statement (amy 1).
(amy count-patients) has input ((surf      utils      ) entry-count).
(amy count-patients) has input ((st-antonius patients-2024) patients ).
(amy count-patients) has output num-patients.
(amy count-patients) ready.
```

After some time, Amy acquires the following statement by St. Antonius, and propagates it to the workers in the system. Whether this statement was made before, or in reaction to Amy's statement is not important; it suffices that all its observers agree that it was authored by St. Antonius. Note that it includes an assertion that St. Antonius controls the patients data, so tasks cannot process it (or its derivatives) without the authorisation of St. Antonius. This authorisation is given by St. Antonius to themselves for task `st-antonius patients-2024`, but not yet for tasks processing the outputs of `st-antonius patients-2024`, *e.g.*, task `amy count-patients`.

```
// Statement (st-antonius 1).
(st-antonius patients-2024) has output patients.
(st-antonius patients-2024) ready.
st-antonius controls ((st-antonius patients-2024) patients).

(st-antonius patients-2024) executed.
authorise (st-antonius patients-2024) in (st-antonius 1) by st-antonius.
```

'Disruptor' Dan observes these statements. Inspired by `st-antonius 1`, Dan attempts to establish control over `patients` by stating `dan 1`. All observers agree that this statement is valid, and, as no action is taken, Dan remains well-behaved. Indeed, it is possible that, after some more statements, actions may be justified using `dan 1`. However, Dan has misunderstood his role in the system. The crucial difference between Dan and St. Antonius is the incentives they provide for agents to accept their conditions of control over `patients`. Only St. Antonius coupled the condition with useful rules, namely, the definition and execution of task `st-antonius patients-2024`. In contrast, there is no incentive to include `dan 1` in justifications, so the statement goes unused, and has no impact on any action taken. Agents who expect this outcome can exercise their right to forget `dan 1` altogether. There also exists no statement (*e.g.*, by Dan) that causes confusion between variables `st-antonius patients` and `dan patients`.

```
// Statement (dan 1)
dan controls ((st-antonius patients-2024) patients).
```

SURF states their own execution of Amy’s task. On its own, `surf 2` is invalid; it appears to execute a task that is not ready! Furthermore, the union of `surf 2` with any subset of the prior statements is invalid, for example, because it lacks the necessary authorisation of St. Antonius. However, this is not a problem; indeed, agents are expected to sometimes make invalid statements, because these ultimately enable the creation of valid justifications later. In this case, the statement enables actions justified by SURF executing Amy’s task `amy count-patients`. Intuitively, SURF lets St. Antonius decide who executes the task. It all depends on who St. Antonius chooses to authorise.

```
// Statement (surf 2).
(amy count-patients) executed.
```

Externally, St. Antonius reasons that they prefer to execute this task themselves, as it requires little work, yet handles extremely sensitive data. They state `st-antonius 2`.

Shortly thereafter, St. Antonius enacts `st-antonius 2` at time 1, with basis `consortium 1`, and justification $\{\text{consortium 1, amy 1, surf 1, st-antonius 1, st-antonius 2}\}$, *i.e.*, all statements so far except $\{\text{dan 1, surf 2}\}$. All observers agree that this is permitted, by Definition 3.3.

- (1) Each message in the justification is **stated**.
- (2) The action is **based** on `consortium 1`, which is a current agreement (in fact, the only one). Recall Property 3.3: agents always agree on the current agreements.
- (3) The policy extracted from the justification is **valid**, because it falsifies `error`. Every observer can verify this independently by extracting the policy from the provided justification, and evaluating the truth of `error`. Because Slick’s inference procedure is deterministic, every observer can be relied upon to reproduce this result.
- (4) The action is **current**, because its basis applies at the current time.

Consequently, all observers agree that this action preserves the good behaviour of St. Antonius. This includes auditors arbitrarily far into the future, as this action is logged alongside sufficient contextual information (*e.g.*, the current time was 1) to check permission. All observers also agree on the effects of the action: St. Antonius reads the entry-count and patient assets, and writes the count asset. Soon afterward, St. Antonius uses this action to mirror these effects in the data plane by reading and writing the asset data assigned to these variables.

```
// Statement (st-antonius 2)
authorise (amy count-patients) in (amy 1) by st-antonius.
((amy count-patients) num-patients) executed.
```

Amy reasons about the ultimately desired effect of `amy reads ((amy count-patients) num-patients)`. Amy’s conclusions are captured in the following statement; Amy plans a final task which has (only) the count as input, and thus, will have the desired effect when enacted.

Amy has the physical capability to enact this statement already, but not without observers agreeing that the action is not permitted! Amy must include `st-antonius 2` in the justification (to witness the execution of the input), but then Amy must include `st-antonius 1` (for the same reason), but then Amy must provide evidence that St. Antonius authorises Amy executing the new task. No existing statement states this, and Amy cannot state it herself (while preserving validity). Amy chooses to remain well-behaved by not acting just yet.

```
// Statement (amy 2)
(amy end) has input ((amy count-patients) num-patients).
(amy end) ready.
(amy end) executed.
```

Upon observing Amy’s new statement, St. Antonius is driven to the obvious conclusion; Amy awaits the authorisation to act. St. Antonius reasons that stating this authorisation would enable Amy enacting the execution of the task, with the effect of Amy reading count, which is a derivative of patients. However, St. Antonius concludes that this derivative of the sensitive data it not sensitive itself, and so there is no harm in Amy reading it. All of this reasoning is hidden from external observers, but its result is publicised as `st-antonius 3`.

```
// Statement (st-antonius 3)
authorise (amy end) in (amy 2) by amy.
```

Upon observing this new statement, Amy enacts the previously stated `amy 2` at time 1, as justified by all statements so far, except for `{surf 2, dan 1}`. Once again, all observers conclude that this action is permitted, and so, it preserves the good behaviour of Amy. All observers agree that this action has the (intended) effect `amy reads num-patients`. Amy externalises this effect by reading the external asset that corresponds to the count variable.

6.3.2. Existing Usage: Distributed Workflow Execution. Like the original BRANE system, our system affords the execution of multi-step workflows over multiple domains.

In this scenario, ‘Bookkeeper’ Bob wants to know how many patients at St. Antonius have consented to the processing of their patient data being read. To achieve this goal, Bob plays the role of another data scientist; Bob encodes the four-task workflow in the following statement. Bob also plays the role of a software provider in Step 1 by providing the `filter-consented` function to be used in Step 2.

The first part of `bob 1` defines new tasks similarly to the previous examples. But Bob also includes additional rules in this statement. Firstly, a rule that asserts the need to plan the execution of all steps beforehand, via a straightforward rule. By including them in one statement, Bob’s task definitions are coupled with Bob’s condition on their execution. It also demonstrates that all agents (not just `consortium`) enjoy the expressive power of conditional rules to assert complex conditional truths. Bob also includes a blanket authorisation of agents to execute any task at all; Bob is not concerned with – nor responsible for – the sensitivity of any data. Finally, Bob plans to execute Steps 1 and 4 himself.

```
// Statement (bob 1).
(bob step1) has output filter-consented.
(bob step1) ready.

(bob step2) has input ((bob step1) filter-consented).
(bob step2) has input ((st-antonius patients-2024) patients).
(bob step2) has output consented.
(bob step2) ready.

(bob step3) has input ((surf utils) entry-count).
(bob step3) has input ((bob step2) consented).
(bob step3) has output num-consented.
(bob step3) ready.

(bob step4) has input ((bob step3) num-consented).
(bob step4) ready.

error if (bob Name1) ready and not (bob Name1) executed and (bob Name2) executed.

authorise Task in Msg by Worker
  if Worker says (Task executed) and (Task ready) within Msg.
```

```
(bob step1) executed.
(bob step4) executed.
```

St. Antonius and SURF observe and reason about Bob’s statement. Externally to the system, they exchange communications, negotiating their possible roles in facilitating the execution. For example, SURF observes that Bob’s statement implies Bob’s authorisation to any executed task, but this is harmless, as it remains useless for tasks not involving Bob. While St. Antonius is willing to execute Step 3, they are unwilling to execute Step 2, as this requires them to execute Bob’s untrusted `filter-consent` with the hospital infrastructure. Fortunately, St. Antonius is willing to let SURF execute Step 2 instead; St. Antonius trusts SURF to read the sensitive patient data, while SURF accepts the risk of executing Bob’s mysterious function. None of this reasoning is revealed to the other agents, but its results are; SURF and St. Antonius make the following two statements, respectively.

```
// Statement (surf 3).
(bob step2) executed.
```

```
// Statement (st-antonius 4).
(bob step3) executed.
authorise (bob step2) in (bob 1) by surf.
authorise (bob step3) in (bob 1) by st-antonius.
authorise (bob step4) in (bob 1) by bob.
```

At this point, the execution of all of Bob’s tasks are justifiable (while preserving validity). Independently, Bob, SURF, and St. Antonius can identify and enact such a justification, *e.g.*, if Bob acts first, Bob can gossip the action to SURF, informing SURF of which justification to use themselves! Each observer agrees on the permission and effects of each of these actions.

While their data-dependencies are *modelled* by their statements as inputs, outputs, reads, and writes, they are not enforced by policy; for example, the above statements suffice to let SURF enact Step 3, even before St. Antonius enacts Step 2. However, of course, these actions are also constrained by their data-dependencies in the data plane, so St. Antonius cannot execute Step 3 until the effects of executing Step 2 are externalised. However, this do not concern policies, justifications, or permissions, so they are not enforced via policies.

6.3.3. Existing Usage: Concurrent Driving, Execution, and Authorisation. In this section, we briefly remark on the observation that our system faithfully reproduces the isolation of independent workflows, *i.e.*, the definition, authorisation, and execution of different workflows proceed concurrently. Concurrent tasks are clearly visible in Figure 8 as each task-pair where neither depends on the other, *e.g.*, `amy end` and `bob step2`. But moreover, unrelated statements are created concurrently also. For example, all the activities of Scenarios 1 and 2 (in Sections 6.3.1 and 6.3.2, respectively) occur concurrently after `patients` is available. For example, if Amy crashes immediately after initialisation, and then stays entirely unresponsive, Scenario 1 cannot complete, but Scenario 2 will still complete successfully.

6.3.4. New Usage: Inter-Domain Policies. Thus far, our scenarios have faithfully reproduced a characteristic of the original BRANE; domain-local policies are entirely private: hidden from other agents, exposed only in the form of particular authorisations, publicised only when needed, on a case-by-case basis. Indeed, this is an important feature of BRANE, which was intentionally developed to handle the eventuality that domain-local policies often reflect private information, thus becoming private themselves [EMvBB22]. However, the

original BRANE offers no way for domains to share policy information. For example, while St. Antonius can send information to SURF via channels outside of BRANE, it is disconnected from SURF's authorisations. In contrast, this scenario demonstrates how our system lets agents cooperate in defining composite Slick policies, leading to authorisation. In general, statements are useful for unifying the *informative* and *regulatory* qualities of policy. In the case of BRANE, statements can publish non-sensitive parts of domain-local policies; recipients of these statements benefit from having insight into the reasoning of the author, while the author benefits from being decoupled from (the work of) justifying other agents' actions.

From Section 6.3.1, it is clear that St. Antonius already models and reasons about the trustworthiness of some agents above others, which ultimately informs which tasks they choose to authorise. But with the following statement, St. Antonius formalises some of this reasoning in a statement, expressed as their conditional authorisation. Consequently, any observer can predict the authorisation of St. Antonius, and under the right conditions, infer it on their behalf. Moreover, the statement formalises the *x is trusted* relation in a form other agents can use, in their own way, and for their own justifications!

```
// Statement (st-antonius 5).
st-antonius is highly trusted. surf is highly trusted.

Agent is trusted if Sayer says (Agent is highly trusted)
    and st-antonius says (Sayer is highly trusted).

authorise Task in Msg by Worker if (Task ready) within Msg
    and st-antonius says (Worker is trusted).
```

Given *st-antonius 5*, SURF defines, readies, and executes the following task, which reads the patient data. Most interestingly, although this task is defined to *involve* St. Antonius, their participation in the action is not required at any point. In this sense, *st-antonius 5* delegated a limited power to authorise on the behalf of the St. Antonius to SURF, despite this requiring SURF to reason about a publicised part of the local policy of St. Antonius.

```
// Statement (surf 4).
(surf read-patients) has input ((st-antonius patients-2024) patients).
(surf read-patients) ready.
(surf read-patients) executed.
```

Next St. Antonius makes the following statement. Like *st-antonius 5*, this statement internalises a facet of their local policy, to the benefit of internalising their reasoning about tasks, with the benefit of letting others systematically reason on their behalf. In this case, it captures the link between (simplified) consent of patients to the processing of their data, and the authorisation by St. Antonius of tasks processing patient data. The JustAct framework affords this usage; for example, this statement enables a fruitful cooperation between St. Antonius, AMdEX, and SURF, which are all (highly) trusted by St. Antonius.

However, unlike *st-antonius 5*, this statement captures sensitive policy information; St. Antonius does not wish to disclose the set of patients to *untrusted* agents! Ideally, statements could be used to regulate such communications via justification and permission, as usual. Unfortunately, JustAct does not (yet) offer a means for agents to internalise this. For example, if SURF forwards *st-antonius 6* to Dan, SURF still satisfies the definition of well-behaved.

```
// Statement (st-antonius 6).
amy is a patient. bob is a patient. dan is a patient.

trusted consent for Task in Msg if st-antonius says (Sayer is trusted)
```

```

and Sayer says (Patient consents to Task in Msg).

Task lacks trusted consent if authorise Task in Msg by Worker via consent
and Patient is a patient and not trusted consent for Task in Msg.

authorise Task in Msg by Worker if Patient consents to Task in Msg
and Worker says (Task executed) and not Task lacks trusted consent.

```

6.3.5. *New Usage: Dynamic Amendment of the Agreement.* So far, all actions have been controlled via the concepts defined in the initial agreement. In this final scenario, we demonstrate more fundamental changes agents are able to make to the agreement in order to alter which actions are justifiable in the future.

After some negotiations, the agents come to the agreement that the initial agreement has some flaws. Namely, (1) SURF lacks control over `entry-count`; they regret providing the asset in `surf 1` unconditionally, and (2) St. Antonius cannot express their involvement in the sensitive `patients` without being involved in its insensitive derivative `count`.

Working together (externally), the agents formulate their changes as statement `consortium 2`, which differs from `consortium 1` in only the following, small details:

- (1) a new rule is added:

```
(surf utils) involves surf.
```

- (2) the existing rules concerning involvement are each given a new condition that the variable in question is not stated to be *insensitive*, which is a novel concept. Precisely, this change is realised as a replacement of those rules with the following:

```

Task involves Agent if Agent controls (Task Label)
and not Agent says ((Task Label) is insensitive).
Task2 involves Agent if Task has input (Task1 Label) and Task1 involves Agent
and not Agent says ((Task Label) is insensitive).

```

These changes have no effect on actions until the agents synchronously create the agreement that `consortium 2` applies at time 2, and advance the current time to time 2. Even then, the prior actions are entirely unaffected, as they were enacted at time 1, when `consortium 1` still applied. However, going forward, the prior justifications would be invalid. In future, actions must be based on `consortium 2`, until the agreements or current time are changed again.

St. Antonius takes advantage of the new notion of insensitive variables by making the following statement. Agents can then justify processing (derivatives of) `count` without the authorisation of St. Antonius, but authorisation is required to process `patients` as before. SURF is also pleased, because they have regained control of `entry-count`, letting them judge each execution before it happens, *e.g.*, to avoid it being used for any nefarious purposes.

```

// Statement (st-antonius 7).
((amy count-patients) count) is insensitive.

```

Some time later, an administrator of the system becomes suspicious that sensitive asset data has somehow leaked to ‘Disruptor’ Dan, via their exploitation of a vulnerability of the external asset store. The administrator exploits their power to ‘break the glass’, seizing emergency powers to regain control of the situation; all actions must be paused to prevent more reading and writing events, until the administrator completes their diagnosis.

This is achieved by the administrator synchronously updating the current time to 3. Consequently, until an agreement applies, well-behaved agents cannot act!

Some time later, the administrator determines that it was a false alarm; Dan did not do anything wrong (yet). The productivity of the system is restored simply by simply agreeing that `consortium 2` applies at time 3. The well-behaved agents resume their work.

6.4. Evaluation of the Case Study. We conclude the case study by evaluating our implementation in application to BRANE’s usage scenarios.

Firstly, we briefly report on the empirical facet of our evaluation of our case study: the performance of our runtime system in each experimental scenario. Table 2 presents our measurements of the run duration for each experimental usage scenario from beginning to end (but after the runtime system and Slick interpreter are compiled). Note that, as our prototype implementation executes in shared memory, these results under-represent the overhead of (de)serialisation and network communication that would be present in realistically-distributed data exchange systems (see Section 4.1). Nevertheless, these results faithfully represent the work of the runtime system itself: (round-robin) scheduling of agents, logical routing of control messages, and logging of agents interaction with (meta) data. It also faithfully represents the work of agents: observing and reacting to their environment, then collecting, composing, interpreting, and evaluating the denotations of received Slick policies, before creating and gossiping statements and actions to their peers.

Scenario	Section	Title	Duration
1	Section 6.3.1	Isolated Execution	$1260 \pm 180\mu s$
2	Section 6.3.2	Distributed Execution	$910 \pm 10\mu s$
3	Section 6.3.3	Concurrency [†]	$2040 \pm 510\mu s$
4	Section 6.3.4	Inter-Domain Policies	$1000 \pm 10\mu s$
5	Section 6.3.5	Dynamic Agreement	$800 \pm 10\mu s$

Table 2: Duration of our experimental data exchange system applied to the five BRANE usage scenarios, each reported as the mean and standard deviation of 10 runs.

[†]We measure the case where Amy does not crash, because otherwise, the scenario has no defined end.

In the remainder, we present the analytical facet of our evaluation of our case study. To structure the discussion, we identify and enumerate the *desirable characteristics* of BRANE-like systems, distinguishing those already (E)xisting in BRANE from those that are (N)ew to BRANE, *i.e.*, present only in our own, experimental version of BRANE. In the discussion to follow, we explicitly connect discussion points to particular desirable characteristics, along with whether each point contributes positively (+) or negatively (−):

- E_1 Data scientists can define arbitrary workflows and read the results of their execution.
- E_2 Software engineers can introduce persistent assets for use as inputs to workflows.
- E_3 The usage of assets is regulated by domain-local policies.
- E_4 Checkers control the exposure of their domain-local policies to other agents.
- E_5 Agents work autonomously, unimpeded by other agents (not) doing unrelated work.
- E_6 Agents straightforwardly reason about their roles in the system.
- N_1 Checkers can express inter-domain policies to share and delegate control over processing.
- N_2 Inter-agent power dynamics are enforced via user-facing domain-local policies.
- N_3 Local deviations from policies that cannot be prevented are reliably detected by auditors.

$\boxed{N_4}$ Agents can robustly reason about and prove the policy-permissibility of their actions.

$\boxed{N_5}$ (Inter-)domain policies are easily and effectively refined and changed at runtime.

Sections 6.3.1 to 6.3.3 focused on the reproduction of existing BRANE functionality. Section 6.3.1 demonstrated defining tasks let ‘Analyst’ Amy, St. Antonius, and SURF each define computational workflow tasks in their own statements. This lets Amy play the role of a workflow provider, ultimately reading the result of executing the workflow ($+E_1$). It also lets SURF and St. Antonius play the role of asset providers, as their task outputs were inputs to Amy’s workflow ($+E_2$). In the case of St. Antonius, patient data was provided along with an assertion of control over the processing of the asset and its derivatives; hence, workers could not justify executing Amy’s workflow tasks without authorisation from St. Antonius ($+E_3$). Actions interfaced with the domain-local policies of their controllers via the latter’s explicit authorisations, which publicised only their policy-decisions themselves ($+E_4$). In fact, as in [EMvBB22], domains could intentionally postpone their authorisations, or mask the lack of authorisation as inactivity, *e.g.*, to mask their reasoning process ($+E_4$). Section 6.3.3 demonstrated how agents’ work went unimpeded by the unrelated (in)activity of their peers, *e.g.*, the processing of Amy’s workflow by St. Antonius was unaffected by SURF offering only an ignored task-execution plan ($+E_5$). Unfortunately, to afford agents playing their BRANE roles, the runtime system had to store many statements, and the agents had to reason about their many complex interactions ($-E_6$). Fortunately, this generalised several distinct processes of the original BRANE system, resulting in an implementation that is more concise by re-using this general solution ($+E_6$). Moreover, as the JustAct framework is based on concepts that stakeholders in BRANE are expected to understand, our hardcoded portion of BRANE is smaller and simpler, and thus easier to reason about and maintain ($+E_6$). Hence, complex BRANE-specific notions (*e.g.*, workers, domains, task execution, and asset providers) can be understood via JustAct concepts, which are common and well-understood in computer science (*e.g.*, agents, messages, signatures, rules, and first-order logic) and in legal regulations (*e.g.*, auditing, powers, actions, agreements, qualification rules, and evidence) ($+E_6$).

Our system confers the BRANE system with (N)ew desirable characteristics. Via the complex Slick rules expressible in statements, domain-local policy providers can choose to internalise facets of their policies into the statements themselves ($+N_1$). For example, in Section 6.3.4, St. Antonius used this feature in two cases. In Case 1, it enabled the explicit communication of a non-sensitive facet of the St. Antonius-local policy to the other agents. SURF benefitted from having more information to drive its local reasoning ($+E_6$), and moreover, it effectively delegated the power to authorise some tasks from St. Antonius to SURF ($+N_1$). By decoupling St. Antonius from some of its work, the system became more fault-tolerant, as new St. Antonius-authorisations could be created even after the St. Antonius agent or network crashed ($+E_5$). In Case 2, St. Antonius internalised a sensitive facet of its local policy ($+N_1$). The JustAct framework enabled just the agents trusted by St. Antonius to observe this information to communicate it, however, this control was external, and was not enforced using the usual action-justification mechanism ($-E_3$). In either case, this delegated reasoning work from domains to other agents, potentially complicating their roles ($-E_6$). But fortunately, agents retained the power to prefer inactivity, *e.g.*, to forget and ignore messages, to protect themselves from being overworked ($+E_5$). Throughout the scenarios, external effects at the domain-level (*e.g.*, the reading and writing of assets) and at the policy-level (*e.g.*, the proof that actions were justified) are connected via explicitly created, signed, communicated, and collected policy meta-data. On the one hand, the correspondence between user input and runtime behaviour is systematically driven, enforced, logged, and

explained to the users concerned with correctness ($+N_2$) and to the agents responsible for the actions ($+N_4$). On the other hand, these activities are programmable via manipulations of the user inputs ($+N_5$). Section 6.3.5 demonstrated that these manipulations can include the fundamentals of the inter-agent power dynamics which were hard-coded in the original BRANE, such as arbitrarily re-defining the notion of *involvement* that relates domain-local policies to the tasks whose execution they regulate ($+N_5$). Fortunately, via the composition control features of Slick [EvB24], many changes are expressible as controlled policy-refinements in statements as usual, thus not needing agents to synchronise. For example, in Section 6.3.2, the statement `bob 1` enforces the obligation to plan Bob’s four workflow tasks together before any are executable, and in Section 6.3.5, `st-antoni` lets St. Antonius opt out of involvement in a particular asset, after judging that its contents are not sensitive information, creating new ways for workers to justify their processing of this asset ($+N_5$). Throughout, agents preserved their autonomy over locally accessible data (E_6), *e.g.*, ‘Defector’ Dan is always free to express any data-access request, which are even realised without permission, but only if the system is configured to do so. But regardless, any actions without permission are systematically logged and detected by any auditors after the fact ($+N_3$).

In summary, our system exhibited all the desirable characteristics to some extent. These improvements (and their limitations) resulted from the more unified and dynamic approach JustAct provides to regulating actions with policies. Our version of BRANE moves some of the burden from the static BRANE implementation to the agents at runtime, thus enabling greater flexibility than in the original BRANE, but requiring care to shield agents from the potential complexity of their interacting policies. The case study also exposed cases where the dynamism of JustAct still does not yet go far enough; *e.g.*, Section 6.3.4 demonstrates a scenario in which it would be useful if agents could use statements to regulate how agents communicate statements. In all scenarios, our version of BRANE benefits from its greater emphasis on accountability; more than ever before, it is clearer how to define, implement, and audit the policy-compliant execution of users’ medical workflows. This functionality was achieved with acceptable runtime performance.

These findings motivate further experiments in future to integrate the features of our experimental runtime system into the real BRANE system. To this end, work remains to evaluate the necessary facets of the real BRANE system which are absent in these experiments: the physical distribution of agents and (meta) data, and the more extensively automated reasoning of agents that are automated in BRANE, including planners and workers.

7. DISCUSSION OF THE FRAMEWORK

This section evaluates the framework in general by reflecting on the processes and results of the implementations and experiments from Sections 4 to 6.

7.1. Strengths of the JustAct Framework.

7.1.1. *Highly Dynamic and Extensible.* The framework is highly abstract, making it applicable to many policy languages and runtime systems.

Notably, the framework is parametric to the statically-defined policy language, admitting any formal language affording pure functions of truth and validity. This leaves significant room for systems instantiating the framework to adopt various notions of policy, with various information models, and various semantics. For example, the framework’s notion of policy

affords the n -ary relations and logical constraints underlying Bell-LaPadua security policies and various Rule-Based Access control policies, which are all summarised and compared in [ZC08], but we leave the development of such to future work.

Moreover, the relations between agents that ultimately control actions are highly dynamically configurable, by agents making statements. Different configurations confer different characteristics on the system, for example, allowing for dynamic specialisation for various use cases in reaction to runtime information. We recognise two noteworthy spectra on which particular system configurations fall. Together, these help to clarify the ways systems can change their characteristics at runtime. Firstly, systems can be centralised (where inter-agent consistency is high, *e.g.*, by most statements being agreements) or decentralised (where many agents can act independently). Secondly, systems can be highly static (where strict agreements are ex-ante enforced, resulting in predictability and efficiency) or highly dynamic (where actions are loosely specified and enforced, resulting in flexibility and autonomy).

7.1.2. Formal Inter-Agent Power Dynamics. The framework is useful if agents agree to preserve their well-behavedness, as it is defined in Definition 3.1: agents take only permitted actions. Thus, policies with complex conditions for permission create complex inter-agent power dynamics, *e.g.*, modelling various common and useful normative concepts. For example, in Section 6.3.4, by stating `st-antonius 5`, the St. Antonius hospital formalises their trusted peers in the `x trusts y` relation, and also delegates their own power of authorisation to their trusted peers. Despite its complexity, `st-antonius 5` has an unambiguous meaning.

Well-behavedness is also robust; an agent that violates their own well-behavedness by taking a non-permitted action preserves the well-behavedness of their peers. This affords meaningful cooperation between well-behaved peers even in the presence of misbehaving peers. The framework lays the foundation for agents to recognise and punish these bad actors, *e.g.*, by cutting them out of future cooperations, ignoring their statements, or affording their punishment by participating in future audits of their actions.

7.1.3. Autonomy and Parallelism. Agents synchronise to change agreements. All other communication can be asynchronous, delayed, and lossy. Agents are very autonomous, as they are never fundamentally compelled to act or make statements. Hence, agents are robust to unreliable peers. The framework affords realistic inter-agent enforcement of well-behavedness: agents monitor actions, and actors bear the burden of proving that their actions are permitted. Thus comes at the cost of burdening actors: they are responsible for justifying their own actions. However, in cases where this burden is too great, agents are free to remain inactive instead; inactivity does not require justification. The framework is also robust to agents arbitrarily forgetting (their local) statement and action information; when these are not part of their existing justifications, this even preserves their well-behavedness.

7.1.4. Consistent Permission despite Privacy. Agents always agree which actions are permitted, despite being defined by statements not known to all agents. This apparent contradiction is resolved by agents being able to decide when their known statements suffice for permission. Moreover, permission is objective; agents are certain that other agents (*e.g.*, future auditors) agree that their actions were permitted, without involving them at all. For example, in Section 6.3.4, the SURF agent can justify actions using `st-antonius 6`, despite this statement being kept private between SURF and St. Antonius. This sensitive statement must only be

observed at the moment the permission of this action is audited. For example, it can be audited by a third party trusted by St. Antonius not to reveal `st-antonius 6`, and trusted by the other agents to accurately judge the permission of the action.

7.2. Limitations of the JustAct Framework.

7.2.1. *Costly Justification Search.* To remain well-behaved, agents cannot act until they have found a justification, by searching through combinations of known statements. In general, this problem is hard, scaling exponentially with the number of statements (the cost of enumerating combinations) and whatever is the language-specific cost of evaluating large policies (the cost of evaluating composite policies). But in practice, the difficulty is curbed by limiting the consideration of statements to a smaller set of simpler policies. Fortunately, because agents act at their own pace (or not at all), each agent can approach this problem as best suits their needs, *e.g.*, by ignoring any statement that they expect to be more complex than it is worth. The cost of justification search can also be curbed more systematically by limiting the expressivity of the policy language. For example, in our case study, we found Slick to be sufficiently complex to express the necessary concepts, yet its policies were evaluated at a speed that was sufficient for our purposes (see Section 6.4), despite our implementation not being optimised for performance. Future work can continue the design of policy languages and implementations and their effect on the cost of justification search. We are also interested in leveraging existing literature and tools to let agents more automatically and efficiently search for justifications. We consider answer set solving (*e.g.*, with Clingo [GKK⁺11]) or model-checking rewrite systems modulo theories (*e.g.*, with Maude [CDE⁺03]).

7.2.2. *No Obligation to Act (in Time).* Our framework offers no fundamental mechanism for agents to compel one another to action. Thus, the framework cannot faithfully internalise normative *obligations to act*. Agents can approximate obligations by conditioning future permissions on proof of their prior actions. This approximation was sufficient to implement the functionality of BRANE in Section 6. Also, any required enforcement of obligations can be built atop the framework, implemented externally, using supplementary systems. However, we expect that agents may have difficulty compelling agents to act before specific deadlines, as a consequence of the aforementioned point on the costly search for justifications. For this reason, our framework is not a natural choice for implementations of *real-time systems*, where agents must react to stimuli within strict deadlines. Future work can investigate constraints on system configurations that strike desirable compromises between system flexibility on the one hand, and predictability of actions (and their timing) on the other.

7.2.3. *Specification of Communication.* It is a key feature of the JustAct framework that permission of given actions is universally agreed by agents, despite each having only a partial view of the existing statements and actions; *i.e.*, the framework works despite agents gossiping statements and actions at their own pace. However, as discussed in Section 6.4, and exemplified in Section 6.3.4, the permission mechanism does not extend to specifying this gossip; *i.e.*, the framework does not afford agents using statements to specify how statements and agreements are communicated. In future work, we want to supplement the current notion of agreements and permissions with a similar mechanism for the communication of

statement and action information, which regulates the sending of statements and actions from one agent to another, and is violated when the information is sent without permission.

7.2.4. No Privacy from the Actor. Agents are only able to act on permissions defined by *known* statements. For example, in Section 6.3.4, for SURF to act while remaining well-behaved, it is necessary for SURF to acquire the sensitive statement `st-antoni`⁶ from the St. Antonius hospital. Moreover, as discussed in Section 7.1.4, auditors of the permission of this action must also observe the statement. At present, these cases can be worked around by hiding the reasoning behind the permission. For example, in this case, some agent can be empowered to decide whether the St. Antonius trusts another given agent, and can hide the reasoning process dependent on the sensitive information previously expressed in statement `st-antoni`⁶. The information can be preserved by (privately) logging a systematic transformation of the reasoning in its entirety to a restricted version, which can be publicised, because it omits the sensitive details. This kind of information hiding has plenty of precedent in the literature. It is even commonplace in the current version of the BRANE system: checkers publicise authorisations, but hide any underlying reasoning. This workaround has the drawback of hiding the reasoning in undesirable cases, *e.g.*, it is hidden from trusted auditors. In future, we want to systematise these intermediary transformations such that the hidden policy information can always be recovered.

8. RELATED WORK

Our framework prescribes a relation between concerns that are each independently explored in the literature: (1) blockchains can synchronise dynamic, decentralised policies, (2) trust management specifies the delegation of power between agents, and (3) Curie evaluates data access policies as a function of sensitive data.

8.1. Smart (Policy) Ledgers atop Blockchains. Distributed ledgers are an abstraction of consistent state over decentralised processes. Blockchains afford robust, probabilistic implementation of distributed ledgers, but they differ in their details; *e.g.*, Fabric emphasises scalability [ABB⁺18], while Ouroboros emphasises provable security [KRDO17].

SmartAccess [dORV⁺22] uses distributed ledgers to store policies and (meta-)data, enabling decentralised implementations of the access-control model whilst affording accountability regarding authorisation. However, this approach imposes a burden on agents to maintain a high level of synchrony in the policy information they create and collect. This imposes unnecessary overhead in cases where policy information is unrelated. For example, the concurrency demonstrated in Section 6.3.3 would be impossible; agents would be forced to synchronise their statements just in case they affect the permissibility of their actions. Moreover, the synchronisation of policies would make it impossible to support cases where policy information captures private information, and thus, should not be broadly publicised. This is demonstrated in Section 6.3.4, where the St. Antonius hospital sends the (trusted) SURF agent some private information to enable new permitted actions.

Other ledger-based systems allow a heterogeneous view on the policy state. For example, Canton [Dig] (whitepaper) replaces the (sequential) *blockchain* with a (hierarchical) *blocktree*. Agents must only synchronise the relevant sub-trees with their neighbours. This lays the groundwork for private policies. This idea is promising and requires further investigation.

We see the various, established ledger and blockchain technologies as ways for our agents to synchronise agreements in particular. But they are unsuitable for distributing all policy information, where ordering and synchronisation is often unnecessary or undesirable.

8.2. Curie. Curie is a policy-based data exchange system [CAA⁺19]. Our works share a fundamentally decentralised approach to the specification and enforcement of formal policies that regulate the exchange of data, based on consortium agreements and local policies. Moreover, both works define permission to act in terms of shared, composite policies. In the case of Curie, data sharing is composed from the policies of agents x and y , requiring their dual views on the sharing: x must specify that data is shared with y , and y must specify that data is acquired from x . We also see similarities between Curie and the EPI framework in their shared application to federated machine learning with sensitive medical data.

The contributions of Curie and JustAct are largely orthogonal, because they are designed to address different kinds of complexity in policies. Curie focuses on complexity arising from the definition, sharing, and regulation of policies following their entanglement with the shared data itself. Policy decisions digest the homomorphically encrypted data [DMGD23], revealing only the evaluation result. For example, a hospital’s sharing policy is conditioned on the data surpassing a threshold of differential privacy [MZ17]. In contrast, JustAct focuses on multiple agents cooperating to define and disseminate policy information on the fly, while preserving the accountability and autonomy of the actors under regulation.

Because Curie and JustAct make largely orthogonal contributions, we see great potential in investigating the combination of their best features. Can we develop runtime systems in which data sharing actions are regulated by policies defined by cooperating agents, as a function of the data itself, while preserving the agents’ accountability, privacy, and autonomy? Can (data sharing) actions be justified as a function of the shared data itself? Can the Curie language be used to express policies to the satisfaction of the JustAct framework requirements? In which applications is this combination fruitful?

8.3. Trust Management. Traditional access control develops languages and tools for specifying and checking a requester’s permission to access data. *Trust management* reifies the role of the accessor as a *certificate*, primarily, to enable access control in a decentralised environment, where the identities of particular requesters are not known ahead of time [BFL96]. Much literature dates to the 1980’s and 1990’s, investigating policy languages suited to defining certificates and inferring them at request time from context. Many of these are extensions of Datalog, *e.g.*, adding non-monotonicity [LGF03], constraints [LM03], and weights [BMS08].

Like access control, trust management focuses agent reasoning on the access-request decision, whereas our framework emphasises the inter-relationship between agents and their actions via their synchronised agreements. However, the bulk of trust management research complements our work, because it informs the selection of particular policy languages suited to particular purposes. [Sac11] overviews and compares (the complexity of) noteworthy trust management languages. Which trust management languages are good candidates for policy languages in the JustAct framework? We expect these to be even more desirable if the framework is extended to support the desirable features explained in Section 7.2.3, empowering policies to specify how agents can communicate statements and actions.

9. CONCLUSION

In this article, we define *JustAct*, a framework for systems driven by autonomous agents whose actions on the system are regulated by the policy information that they define, communicate, and assemble. Our work is motivated by the problem of exchanging sensitive (*e.g.*, medical) data between autonomous agents, where it is crucial that (1) agents can define adjustable policies that regulate their peers' usage of their data, and (2) agents cannot always publicise the policy information that justifies their actions, as it captures sensitive information.

Our framework is instantiated by runtime systems whose behaviour is unfolded at runtime by multiple, autonomous agents communicating statements (carrying policy information) and taking actions (whose effects connect to events that are external to the regulated system). To maximise the applicability of our work to existing literature and in existing systems, we do not fix the language agents use to express policies. In general, it suffices for the language to meet our minimal specification. Intuitively, each policy must be communicable in messages, and determine the *validity* and *effects* of a given action. Crucially, agents agree whether a given action is *justified* by a given policy at a given time. Hence, actors can decide and prove that their actions are permitted, such that future auditors come to the same decision. The space of justifications remains flexible, yet unambiguous, because agents maintain consensus on the changing set of *agreements* which are the basis of future actions.

We evaluated our framework in application to a representative case; we apply a Rust implementation of *JustAct* in a runtime system and policy interpreter to usage scenarios of *BRANE*, an existing medical workflow execution system. Desirable features are reproduced successfully: data scientist users can define workflow tasks, workers can execute them, while domain-checkers regulate the processing of domain-controlled medical data. Users enjoy the typical benefits of *BRANE*: domain-policies are programmable, and data-independent tasks complete concurrently. Moreover, our approach affords greater expressivity and flexibility in the regulation of workflow execution. For example, we demonstrate agents dynamically delegating their power to authorise workflow tasks, and amending the roles of agents in workflow execution, while preserving their fundamental consensus on which actions (in the past and future) are permitted, and what are their effects on the medical data.

We discussed the generalisability of these findings to other systems, remarking on the strengths and limitations of our approach in general. The strengths follow from systematising the connection between agents and programmable policies, laying the groundwork for unified approaches to various tasks that are difficult when they are separated; for example, our agents use policies to (1) formalise the connection between system events and external sources of regulatory norms such as the GDPR, (2) audit the permission of existing actions, (3) plan actions that have desirable effects, and (4) identify policy amendments and changes that afford desirable actions. There are two kinds of limitation to our work. Firstly, the additional flexibility and dynamism our framework demands of the system comes at the cost of computational complexity. To some extent, this is unavoidable, arising as a necessity of systems being designed to exploit the novel flexibility we provide to the dynamics between agents. However, the logical, systematic nature of our policies affords the application of existing language-design and system-analysis techniques to designing policy languages and policies to strike better compromises between flexibility and simplicity. Secondly, we have identified extensions of this framework that push it yet further in the direction of linking policies to agent behaviour. For example, we see promise in future work extending the notion of permission; we want statements to regulate how statements are communicated.

ACKNOWLEDGMENT

This research is partially funded by the EPI project (NWO grant 628.011.028), the AMdEX-fieldlab project (Kansen Voor West EFRO grant KVV00309), and the AMdEX-DMI project (Dutch Metropolitan Innovations ecosystem for smart and sustainable cities, made possible by the Nationaal Groeifonds).

REFERENCES

- [ABB⁺18] Elli Androulaki, Artem Barger, Vita Bortnikov, Christian Cachin, Konstantinos Christidis, Angelo De Caro, David Enyeart, Christopher Ferris, Gennady Laventman, Yacov Manevich, Srinivasan Muralidharan, Chet Murthy, Binh Nguyen, Manish Sethi, Gari Singh, Keith Smith, Alessandro Sorniotti, Chrysoula Stathakopoulou, Marko Vukolic, Sharon Weed Cocco, and Jason Yellick. Hyperledger fabric: a distributed operating system for permissioned blockchains. In Rui Oliveira, Pascal Felber, and Y. Charlie Hu, editors, *Proceedings of the Thirteenth EuroSys Conference, EuroSys 2018, Porto, Portugal, April 23-26, 2018*, pages 30:1–30:15. ACM, 2018. doi:10.1145/3190508.3190538.
- [AGNvdT13] Giulia Andrighetto, Guido Governatori, Pablo Noriega, and Leendert W. N. van der Torre, editors. *Normative Multi-Agent Systems*, volume 4 of *Dagstuhl Follow-Ups*. Schloss Dagstuhl - Leibniz-Zentrum für Informatik, 2013.
- [AK22] Ines Akaichi and Sabrina Kirrane. Usage control specification, enforcement, and robustness: A survey. *CoRR*, abs/2203.04800, 2022. arXiv:2203.04800, doi:10.48550/arXiv.2203.04800.
- [ANP⁺03] Anne Anderson, Anthony Nadalin, B Parducci, D Engovatov, H Lockhart, M Kudo, P Humenn, S Godik, S Anderson, S Crocker, et al. extensible access control markup language (xacml) version 1.0. *Oasis*, 2003.
- [ASB15] Paulo Sérgio Almeida, Ali Shoker, and Carlos Baquero. Efficient state-based crdts by delta-mutation. In Ahmed Bouajjani and Hugues Fauconnier, editors, *Networked Systems - Third International Conference, NETYS 2015, Agadir, Morocco, May 13-15, 2015, Revised Selected Papers*, volume 9466 of *Lecture Notes in Computer Science*, pages 62–76. Springer, 2015. doi:10.1007/978-3-319-26850-7_5.
- [BCFH08] Rena Bakhshi, Lucia Cloth, Wan J. Fokkink, and Boudewijn R. Haverkort. Meanfield analysis for the evaluation of gossip protocols. *SIGMETRICS Perform. Evaluation Rev.*, 36(3):31–39, 2008. doi:10.1145/1481506.1481513.
- [BFL96] Matt Blaze, Joan Feigenbaum, and Jack Lacy. Decentralized trust management. In *1996 IEEE Symposium on Security and Privacy, May 6-8, 1996, Oakland, CA, USA*, pages 164–173. IEEE Computer Society, 1996. doi:10.1109/SECPRI.1996.502679.
- [BMS08] Stefano Bistarelli, Fabio Martinelli, and Francesco Santini. Weighted datalog and levels of trust. In *Proceedings of the The Third International Conference on Availability, Reliability and Security, ARES 2008, March 4-7, 2008, Technical University of Catalonia, Barcelona, Spain*, pages 1128–1134. IEEE Computer Society, 2008. doi:10.1109/ARES.2008.197.
- [BvdT08] Guido Boella and Leendert W. N. van der Torre. Substantive and procedural norms in normative multiagent systems. *J. Appl. Log.*, 6(2):152–171, 2008. doi:10.1016/j.jal.2007.06.006.
- [CAA⁺19] Z. Berkay Celik, Abbas Acar, Hidayet Aksu, Ryan Sheatsley, Patrick D. McDaniel, and A. Selcuk Uluagac. Curie: Policy-based secure data exchange. In Gail-Joon Ahn, Bhavani Thuraisingham, Murat Kantarcioglu, and Ram Krishnan, editors, *Proceedings of the Ninth ACM Conference on Data and Application Security and Privacy, CODASPY 2019, Richardson, TX, USA, March 25-27, 2019*, pages 121–132. ACM, 2019. doi:10.1145/3292006.3300042.
- [CDE⁺03] Manuel Clavel, Francisco Durán, Steven Eker, Patrick Lincoln, Narciso Martí-Oliet, José Meseguer, and Carolyn L. Talcott. The maude 2.0 system. In Robert Nieuwenhuis, editor, *Rewriting Techniques and Applications, 14th International Conference, RTA 2003, Valencia, Spain, June 9-11, 2003, Proceedings*, volume 2706 of *Lecture Notes in Computer Science*, pages 76–87. Springer, 2003. doi:10.1007/3-540-44881-0_7.
- [CGMT15] Marco Calautti, Sergio Greco, Cristian Molinaro, and Irina Trubitsyna. Checking termination of datalog with function symbols through linear constraints. In Domenico Lembo, Riccardo

- Torlone, and Andrea Marrella, editors, *23rd Italian Symposium on Advanced Database Systems, SEBD 2015, Gaeta, Italy, June 14-17, 2015*, pages 192–199. Curran Associates, Inc., 2015.
- [CGT89] Stefano Ceri, Georg Gottlob, and Letizia Tanca. What you always wanted to know about datalog (and never dared to ask). *IEEE Trans. Knowl. Data Eng.*, 1(1):146–166, 1989. doi: 10.1109/69.43410.
- [Cho95] Jan Chomicki. Depth-bounded bottom-up evaluation of logic programs. *The Journal of Logic Programming*, 25(1):1–31, 1995.
- [CT22] Edward Curry and Tuomo Tuikka. An organizational maturity model for data spaces: A data sharing wheel approach. In Edward Curry, Simon Scerri, and Tuomo Tuikka, editors, *Data Spaces - Design, Deployment and Future Directions*, pages 21–42. Springer, 2022. doi: 10.1007/978-3-030-98636-0_2.
- [Dig] Digital Asset. Canton network: A network of networks for smart contract applications. Available at <https://www.digitalasset.com/hubfs/Canton/Canton%20Network%20-%20White%20Paper.pdf> (Accessed: 23-2-2024). (Whitepaper).
- [DMGD23] Thi Van Thao Doan, Mohamed-Lamine Messai, Gérald Gavin, and Jérôme Darmont. A survey on implementations of homomorphic encryption schemes. *J. Supercomput.*, 79(13):15098–15139, 2023. doi:10.1007/S11227-023-05233-Z.
- [dORV⁺22] Marcela Tuler de Oliveira, Lúcio Henrik A. Reis, Yiannis Verginadis, Diogo Menezes Ferrazani Mattos, and Silvia Delgado Olabarriaga. Smartaccess: Attribute-based access control system for medical records based on smart contracts. *IEEE Access*, 10:117836–117854, 2022. doi: 10.1109/ACCESS.2022.3217201.
- [EMvB24] Christopher A. Esterhuysen, Tim Müller, and L. Thomas van Binsbergen. Justact: Actions universally justified by partial dynamic policies. In Valentina Castiglioni and Adrian Francalanza, editors, *Formal Techniques for Distributed Objects, Components, and Systems - 44th IFIP WG 6.1 International Conference, FORTE 2024, Held as Part of the 19th International Federated Conference on Distributed Computing Techniques, DisCoTec 2024, Groningen, The Netherlands, June 17-21, 2024, Proceedings*, volume 14678 of *Lecture Notes in Computer Science*, pages 60–81. Springer, 2024. doi:10.1007/978-3-031-62645-6_4.
- [EMvBB22] Christopher A. Esterhuysen, Tim Müller, L. Thomas van Binsbergen, and Adam S. Z. Belloum. Exploring the enforcement of private, dynamic policies on medical workflow execution. In *18th IEEE International Conference on e-Science, e-Science 2022, Salt Lake City, UT, USA, October 11-14, 2022*, pages 481–486. IEEE, 2022. doi:10.1109/ESCIENCE55777.2022.00086.
- [Eur16] European Commission. Regulation (EU) 2016/679 of the European Parliament and of the Council of 27 April 2016 on the protection of natural persons with regard to the processing of personal data and on the free movement of such data, and repealing Directive 95/46/EC (General Data Protection Regulation) (Text with EEA relevance), 2016. URL: <https://eur-lex.europa.eu/eli/reg/2016/679/oj>.
- [EvB24] Christopher A Esterhuysen and L Thomas van Binsbergen. Cooperative specification via composition control. In *Proceedings of the 17th ACM SIGPLAN International Conference on Software Language Engineering*, pages 2–15, 2024.
- [Fer23] Raul Castro Fernandez. Data-sharing markets: Model, protocol, and algorithms to incentivize the formation of data-sharing consortia. *Proc. ACM Manag. Data*, 1(2):172:1–172:25, 2023. doi:10.1145/3589317.
- [FJT22] Georgios Fragkos, Jay Johnson, and Eirini-Eleni Tsiropoulou. Dynamic role-based access control policy for smart grid applications: An offline deep reinforcement learning approach. *IEEE Trans. Hum. Mach. Syst.*, 52(4):761–773, 2022. doi:10.1109/THMS.2022.3163185.
- [GIM⁺18] Guido Governatori, Florian Idelberger, Zoran Milosevic, Régis Riveret, Giovanni Sartor, and Xiwei Xu. On legal contracts, imperative and declarative smart contracts, and blockchain systems. *Artif. Intell. Law*, 26(4):377–409, 2018. doi:10.1007/s10506-018-9223-3.
- [GKK⁺11] Martin Gebser, Benjamin Kaufmann, Roland Kaminski, Max Ostrowski, Torsten Schaub, and Marius Schneider. Potassco: The potsdam answer set solving collection. *AI Commun.*, 24(2):107–124, 2011. doi:10.3233/AIC-2011-0491.
- [GL88] Michael Gelfond and Vladimir Lifschitz. The stable model semantics for logic programming. In Robert A. Kowalski and Kenneth A. Bowen, editors, *Logic Programming, Proceedings of*

- the Fifth International Conference and Symposium, Seattle, Washington, USA, August 15-19, 1988 (2 Volumes)*, pages 1070–1080. MIT Press, 1988.
- [GM84] Joseph A. Goguen and José Meseguer. Equality, types, modules, and (why not ?) generics for logic programming. *J. Log. Program.*, 1(2):179–210, 1984. doi:10.1016/0743-1066(84)90004-9.
- [GMT13] Sergio Greco, Cristian Molinaro, and Irina Trubitsyna. Logic programming with function symbols: Checking termination of bottom-up evaluation through program adornments. *Theory Pract. Log. Program.*, 13(4-5):737–752, 2013. doi:10.1017/S147106841300046X.
- [HIA⁺23] Ali Hariri, Amjad Ibrahim, Bithin Alangot, Subhajit Bandopadhyay, Antonio La Marra, Alessandro Rosetti, Hussein Joumaa, and Theo Dimitrakos. *UCON+: Comprehensive Model, Architecture and Implementation for Usage Control and Continuous Authorization*, pages 209–226. Springer International Publishing, Cham, 2023. doi:10.1007/978-3-031-16088-2_10.
- [Ian07] Renato Ianella. Open digital rights language (odrl). *Open Content Licensing: Cultivating the Creative Commons*, 2007.
- [JD22] Christian Jung and Jörg Dörr. Data usage control. In Boris Otto, Michael ten Hompel, and Stefan Wrobel, editors, *Designing Data Spaces: The Ecosystem Approach to Competitive Advantage*, pages 129–146. Springer, 2022. doi:10.1007/978-3-030-93975-5_8.
- [KAA⁺24] Jamila Alsayed Kassem, Corinne G. Allaart, Saba Amiri, Milen G. Kebede, Tim Müller, Rosanne Turner, Adam Belloum, L. Thomas van Binsbergen, Peter Grunwald, Aart van Halteren, Paola Grosso, Cees de Laat, and Sander Klous. Building a digital health twin for personalized intervention: The EPI project. In Boudewijn R. Haverkort, Aldert de Jongste, Pieter van Kuilenburg, and Ruben D. Vromans, editors, *Commit2Data*, volume 124 of *OASICs*, pages 2:1–2:18. Schloss Dagstuhl - Leibniz-Zentrum für Informatik, 2024. URL: <https://doi.org/10.4230/OASICs.Commit2Data.2>, doi:10.4230/OASICs.COMMIT2DATA.2.
- [KdHH22] Misbah Khan, Frank T. H. den Hartog, and Jiankun Hu. A survey and ontology of blockchain consensus algorithms for resource-constrained iot systems. *Sensors*, 22(21):8188, 2022. doi:10.3390/S22218188.
- [KdLTG20] Jamila Alsayed Kassem, Cees de Laat, Arie Taal, and Paola Grosso. The EPI framework: A dynamic data sharing framework for healthcare use cases. *IEEE Access*, 8:179909–179920, 2020. doi:10.1109/ACCESS.2020.3028051.
- [KK20] Bas Ketsman and Christoph Koch. Datalog with negation and monotonicity. In Carsten Lutz and Jean Christoph Jung, editors, *23rd International Conference on Database Theory, ICDT 2020, March 30-April 2, 2020, Copenhagen, Denmark*, volume 155 of *LIPICs*, pages 19:1–19:18. Schloss Dagstuhl - Leibniz-Zentrum für Informatik, 2020. doi:10.4230/LIPICs.ICDT.2020.19.
- [KME⁺24] Jamila Alsayed Kassem, Tim Müller, Christopher A. Esterhuysen, Milen G. Kebede, Anwar Osseyran, and Paola Grosso. The epi framework: A data privacy by design framework to support healthcare use cases. *Future Generation Computer Systems*, page 107550, 2024. URL: <https://www.sciencedirect.com/science/article/pii/S0167739X24005144>, doi:10.1016/j.future.2024.107550.
- [KRDO17] Aggelos Kiayias, Alexander Russell, Bernardo David, and Roman Oliynykov. Ouroboros: A provably secure proof-of-stake blockchain protocol. In Jonathan Katz and Hovav Shacham, editors, *Advances in Cryptology - CRYPTO 2017 - 37th Annual International Cryptology Conference, Santa Barbara, CA, USA, August 20-24, 2017, Proceedings, Part I*, volume 10401 of *Lecture Notes in Computer Science*, pages 357–388. Springer, 2017. doi:10.1007/978-3-319-63688-7_12.
- [KT22] Pooja Khobragade and Ashok Kumar Turuk. Blockchain consensus algorithms: A survey. In Javier Prieto, Francisco Luis Benítez Martínez, Stefano Ferretti, David Arroyo Guardoño, and Pedro Tomás Nevado-Batalla, editors, *Blockchain and Applications, 4th International Congress, BLOCKCHAIN 2022, L'Aquila, Italy, 13-15 July 2022*, volume 595 of *Lecture Notes in Networks and Systems*, pages 198–210. Springer, 2022. doi:10.1007/978-3-031-21229-1_19.
- [KVBG21] Jamila Alsayed Kassem, Onno Valkering, Adam Belloum, and Paola Grosso. EPI framework: Approach for traffic redirection through containerised network functions. In *17th IEEE International Conference on eScience, eScience 2021, Innsbruck, Austria, September 20-23, 2021*, pages 80–89. IEEE, 2021. doi:10.1109/eScience51609.2021.00018.

- [LGF03] Ninghui Li, Benjamin N. Grosf, and Joan Feigenbaum. Delegation logic: A logic-based approach to distributed authorization. *ACM Trans. Inf. Syst. Secur.*, 6(1):128–171, 2003. doi:10.1145/605434.605438.
- [Llo84] John W. Lloyd. *Foundations of Logic Programming, 1st Edition*. Springer, 1984.
- [LM03] Ninghui Li and John C. Mitchell. DATALOG with constraints: A foundation for trust management languages. In Verónica Dahl and Philip Wadler, editors, *Practical Aspects of Declarative Languages, 5th International Symposium, PADL 2003, New Orleans, LA, USA, January 13-14, 2003, Proceedings*, volume 2562 of *Lecture Notes in Computer Science*, pages 58–73. Springer, 2003. doi:10.1007/3-540-36388-2_6.
- [MLP⁺19] Andres Munoz-Arcentales, Sonsoles López-Pernas, Alejandro Pozo, Álvaro Alonso, Joaquín Salvachúa, and Gabriel Huecas. An architecture for providing data usage and access control in data sharing ecosystems. In Elhadi M. Shakshuki, Ansar-Ul-Haque Yasar, and Haroon Malik, editors, *The 10th International Conference on Emerging Ubiquitous Systems and Pervasive Networks (EUSPN 2019) / The 9th International Conference on Current and Future Trends of Information and Communication Technologies in Healthcare (ICTH-2019) / Affiliated Workshops, Coimbra, Portugal, November 4-7, 2019*, volume 160 of *Procedia Computer Science*, pages 590–597. Elsevier, 2019. doi:10.1016/J.PROCS.2019.11.042.
- [MWY17] Xinjun Mao, QiuZhen Wang, and Sen Yang. A survey of agent-oriented programming from software engineering perspective. *Web Intell.*, 15(2):143–163, 2017. doi:10.3233/WEB-170357.
- [MZ17] Payman Mohassel and Yupeng Zhang. Secureml: A system for scalable privacy-preserving machine learning. In *2017 IEEE Symposium on Security and Privacy, SP 2017, San Jose, CA, USA, May 22-26, 2017*, pages 19–38. IEEE Computer Society, 2017. doi:10.1109/SP.2017.12.
- [PRR⁺22] Alireza Parvizmosaed, Marco Roveri, Aidin Rasti, Daniel Amyot, Luigi Logrippo, and John Mylopoulos. Model-checking legal contracts with symboleopc. In Eugene Syriani, Houari A. Sahraoui, Nelly Bencomo, and Manuel Wimmer, editors, *Proceedings of the 25th International Conference on Model Driven Engineering Languages and Systems, MODELS 2022, Montreal, Quebec, Canada, October 23-28, 2022*, pages 278–288. ACM, 2022. doi:10.1145/3550355.3552449.
- [Prz90] Teodor C. Przymusiński. The well-founded semantics coincides with the three-valued stable semantics. *Fundam. Inform.*, 13(4):445–463, 1990.
- [QTD⁺20] Jing Qiu, Zhihong Tian, Chunlai Du, Qi Zuo, Shen Su, and Binxing Fang. A survey on access control in the age of internet of things. *IEEE Internet Things J.*, 7(6):4682–4696, 2020. doi:10.1109/JIOT.2020.2969326.
- [RBA05] Wei Ren, Randal W. Beard, and Ella M. Atkins. A survey of consensus problems in multi-agent coordination. In *American Control Conference, ACC 2005, Portland, OR, USA, 8-10 June, 2005*, pages 1859–1864. IEEE, 2005. doi:10.1109/ACC.2005.1470239.
- [Ros90] Kenneth A. Ross. Modular stratification and magic sets for DATALOG programs with negation. In Daniel J. Rosenkrantz and Yehoshua Sagiv, editors, *Proceedings of the Ninth ACM SIGACT-SIGMOD-SIGART Symposium on Principles of Database Systems, April 2-4, 1990, Nashville, Tennessee, USA*, pages 161–171. ACM Press, 1990. doi:10.1145/298514.298558.
- [RU95] Raghu Ramakrishnan and Jeffrey D. Ullman. A survey of deductive database systems. *J. Log. Program.*, 23(2):125–149, 1995. doi:10.1016/0743-1066(94)00039-9.
- [S⁺06] Douglas C Schmidt et al. Model-driven engineering. *Computer-IEEE Computer Society*, 39(2):25, 2006.
- [SA19] Christian Strasser and G. Aldo Antonelli. Non-monotonic Logic. In Edward N. Zalta, editor, *The Stanford Encyclopedia of Philosophy*. Metaphysics Research Lab, Stanford University, Summer 2019 edition, 2019.
- [Sac11] Krzysztof Sacha. Trust management languages and complexity. In Robert Meersman, Tharam S. Dillon, Pilar Herrero, Akhil Kumar, Manfred Reichert, Li Qing, Beng Chin Ooi, Ernesto Damiani, Douglas C. Schmidt, Jules White, Manfred Hauswirth, Pascal Hitzler, and Mukesh K. Mohania, editors, *On the Move to Meaningful Internet Systems: OTM 2011 - Confederated International Conferences: CoopIS, DOA-SVI, and ODBASE 2011, Hersonissos, Crete, Greece, October 17-21, 2011, Proceedings, Part II*, volume 7045 of *Lecture Notes in Computer Science*, pages 588–604. Springer, 2011. doi:10.1007/978-3-642-25106-1_12.

- [San98] Ravi S. Sandhu. Role-based access control. *Adv. Comput.*, 46:237–286, 1998. doi:10.1016/S0065-2458(08)60206-5.
- [SD94] Danny De Schreye and Stefaan Decorte. Termination of logic programs: The never-ending story. *J. Log. Program.*, 19/20:199–260, 1994. doi:10.1016/0743-1066(94)90027-2.
- [SdV00] Pierangela Samarati and Sabrina De Capitani di Vimercati. Access control: Policies, models, and mechanisms. In Riccardo Focardi and Roberto Gorrieri, editors, *Foundations of Security Analysis and Design, Tutorial Lectures [revised versions of lectures given during the IFIP WG 1.7 International School on Foundations of Security Analysis and Design, FOSAD 2000, Bertinoro, Italy, September 2000]*, volume 2171 of *Lecture Notes in Computer Science*, pages 137–196. Springer, 2000. doi:10.1007/3-540-45608-2_3.
- [Sho93] Yoav Shoham. Agent-oriented programming. *Artif. Intell.*, 60(1):51–92, 1993. doi:10.1016/0004-3702(93)90034-9.
- [SMV⁺19] Sara Shakeri, Valentina Maccatrozzo, Lourens E. Veen, Rena Bakhshi, Leon Gommans, Cees de Laat, and Paola Grosso. Modeling and matching digital data marketplace policies. In *15th International Conference on eScience, eScience 2019, San Diego, CA, USA, September 24-27, 2019*, pages 570–577. IEEE, 2019. doi:10.1109/ESCIENCE.2019.00078.
- [SO17] Daniel Servos and Sylvia L. Osborn. Current research and open problems in attribute-based access control. *ACM Comput. Surv.*, 49(4):65:1–65:45, 2017. doi:10.1145/3007204.
- [SP03] Ravi Sandhu and Jaehong Park. Usage control: A vision for next generation access control. In Vladimir Gorodetsky, Leonard Popyack, and Victor Skormin, editors, *Computer Network Security*, pages 17–31, Berlin, Heidelberg, 2003. Springer Berlin Heidelberg. doi:10.1007/978-3-540-45215-7_2.
- [SPA⁺20] Sepehr Sharifi, Alireza Parvizmosaed, Daniel Amyot, Luigi Logrippo, and John Mylopoulos. Symboleo: Towards a specification language for legal contracts. In Travis D. Breaux, Andrea Zisman, Samuel Fricker, and Martin Glinz, editors, *28th IEEE International Requirements Engineering Conference, RE 2020, Zurich, Switzerland, August 31 - September 4, 2020*, pages 364–369. IEEE, 2020. doi:10.1109/RE48521.2020.00049.
- [SZ94] Baile Shi and Aoying Zhou. Bottom-up evaluation of datalog with negation. *J. Comput. Sci. Technol.*, 9(3):229–244, 1994. doi:10.1007/BF02939504.
- [TGMD22] Ana I. Torre-Bastida, Guillermo Gil, Raúl Miñón, and Josu Díaz-de-Arcaya. Technological perspective of data governance in data space ecosystems. In Edward Curry, Simon Scerri, and Tuomo Tuikka, editors, *Data Spaces - Design, Deployment and Future Directions*, pages 65–87. Springer, 2022. doi:10.1007/978-3-030-98636-0_4.
- [UMSB12] Um-e-Ghazia, Rahat Masood, Muhammad Awais Shibli, and Muhammad Bilal. Usage control model specification in XACML policy language - XACML policy engine of UCON. In Agostino Cortesi, Nabendu Chaki, Khalid Saeed, and Slawomir T. Wierzchon, editors, *Computer Information Systems and Industrial Management - 11th IFIP TC 8 International Conference, CISIM 2012, Venice, Italy, September 26-28, 2012. Proceedings*, volume 7564 of *Lecture Notes in Computer Science*, pages 68–79. Springer, 2012. doi:10.1007/978-3-642-33260-9_5.
- [vBKB⁺21] L. Thomas van Binsbergen, Milen G. Kebede, Joshua Baugh, Tom M. van Engers, and Dannis G. van Vuurden. Dynamic generation of access control policies from social policies. In Nuno Varandas, Ansar-Ul-Haque Yasar, Haroon Malik, and Stéphane Galland, editors, *The 12th International Conference on Emerging Ubiquitous Systems and Pervasive Networks (EUSPN 2021) / The 11th International Conference on Current and Future Trends of Information and Communication Technologies in Healthcare (ICTH-2021), Leuven, Belgium, November 1-4, 2021*, volume 198 of *Procedia Computer Science*, pages 140–147. Elsevier, 2021. doi:10.1016/j.procs.2021.12.221.
- [vBLvDvE20] L. Thomas van Binsbergen, Lu-Chi Liu, Robert van Doesburg, and Tom M. van Engers. eflint: a domain-specific language for executable norm specifications. In Martin Erwig and Jeff Gray, editors, *GPCE '20: Proceedings of the 19th ACM SIGPLAN International Conference on Generative Programming: Concepts and Experiences, Virtual Event, USA, November 16-17, 2020*, pages 124–136. ACM, 2020. doi:10.1145/3425898.3426958.
- [VC07] Francesco Viganò and Marco Colombetti. Symbolic model checking of institutions. In Maria L. Gini, Robert J. Kauffman, Donna Sarppo, Chrysanthos Dellarocas, and Frank Dignum, editors, *Proceedings of the 9th International Conference on Electronic Commerce: The Wireless World*

- of Electronic Commerce, 2007, University of Minnesota, Minneapolis, MN, USA, August 19-22, 2007*, volume 258 of *ACM International Conference Proceeding Series*, pages 35–44. ACM, 2007. doi:10.1145/1282100.1282109.
- [VCB21] Onno Valkering, Reginald Cushing, and Adam Belloum. Brane: A framework for programmable orchestration of multi-site applications. In *17th IEEE International Conference on eScience, eScience 2021, Innsbruck, Austria, September 20-23, 2021*, pages 277–282. IEEE, 2021. doi:10.1109/ESCIENCE51609.2021.00056.
- [VGRS91] Allen Van Gelder, Kenneth A. Ross, and John S. Schlipf. The well-founded semantics for general logic programs. *Journal of the ACM*, 38(3):619–649, July 1991. doi:10.1145/116825.116838.
- [Wes13] Newcomb Hohfeld Wesley. Some fundamental legal conceptions as applied in judicial reasoning. *The Yale Law Journal*, 23(1):16, 1913.
- [ZBL⁺23] Xin Zhou, Adam Belloum, Michael Harold Lees, Tom M. van Engers, and Cees de Laat. The dynamics of corruption under an optional external supervision service. *Appl. Math. Comput.*, 457:128172, 2023. doi:10.1016/J.AMC.2023.128172.
- [ZC08] Gansen Zhao and David W. Chadwick. On the modeling of bell-lapadula security policies using RBAC. In *17th IEEE International Workshops on Enabling Technologies: Infrastructures for Collaborative Enterprises, WETICE 2008, Rome, Italy, June 23-25, 2008, Proceedings*, pages 257–262. IEEE Computer Society, 2008. doi:10.1109/WETICE.2008.34.
- [ZPSP05] Xinwen Zhang, Francesco Parisi-Presicce, Ravi S. Sandhu, and Jaehong Park. Formal model and policy specification of usage control. *ACM Trans. Inf. Syst. Secur.*, 8(4):351–387, 2005. doi:10.1145/1108906.1108908.