

Compact Probe Request Fingerprinting with Asymmetric Pairwise Boosting

Giovanni Baccichet, Fabio Palmese, Alessandro E. C. Redondi, Matteo Cesana
Dipartimento di Elettronica, Informazione e Bioingegneria, Politecnico di Milano
email: {name.surname}@polimi.it

Abstract—Probe Requests are Wi-Fi management frames periodically sent by devices during network discovery. Tracking Probe Requests over time offers insights into movement patterns, traffic flows, and behavior trends, which are keys in applications such as urban planning, human mobility analysis, and retail analytics. To protect user privacy, techniques such as MAC address randomization are employed, periodically altering device MAC addresses to limit tracking. However, research has shown that these privacy measures can be circumvented. By analyzing the Information Elements (IE) within the Probe Request body, it is possible to fingerprint devices and track users over time. This paper presents a machine learning-based approach for fingerprinting Wi-Fi Probe Requests in a compact fashion. We utilize Asymmetric Pairwise Boosting to learn discriminating filters which are then used to process specific bit sequences in Probe Request frames, and quantize the results into a compact binary format. Extensive evaluation on public datasets demonstrates a two-order-of-magnitude storage reduction compared to existing methods while maintaining robust fingerprinting performance.

Index Terms—Wi-Fi, Binary Descriptors, Compression, MAC Randomization, Boosting

I. INTRODUCTION

Wi-Fi devices periodically transmit unencrypted frames, known as Probe Request (PR), to search for available networks in their proximity. The collection of such frames enable entities such as urban planners, transportation authorities, and commercial enterprises to monitor and analyze urban flows, occupancy estimation, and extract useful metrics for resource planning [1].

Extracting information from collected PR frames is however very challenging nowadays, due to two main reasons:

- 1) **Storage Footprint:** The massive proliferation of Wi-Fi devices has led to an exponential growth in PRs volume, overwhelming traditional storage and management capabilities. This growth in data presents significant challenges in terms of cost and complexity.
- 2) **MAC Address Randomization:** To avoid unauthorized eavesdroppers from tracking a device, one of the most popular countermeasures implemented nowadays is Media Access Control (MAC) Address randomization, where a device generates randomized addresses used in a pseudo-random pattern during the PR emission process, hindering tracking.

Methods to counteract MAC address randomization have been a focal point of recent research efforts [2], [3]: such methods attempt to extract fingerprints from Information Elements (IEs) contained in the payload of PR frames, that can be later

used to track a device without relying on its MAC address. However, little attention has been given to the problem of handling or compressing large volumes of PRs efficiently. Compression techniques tailored to PRs allow to significantly reduce the storage footprint of these requests without losing critical information. This not only helps in lowering storage costs but can also enhance data processing efficiency, enabling quicker and less consuming analysis. Ultimately, the ability to compress PRs ensures that the benefits of monitoring and analyzing Wi-Fi signals can be sustained as the number of connected devices continues to rise.

Our goal within this study is to design a compact yet discriminative PR fingerprint. In order to do this, we rely and adapt a Machine Learning (ML) approach named Asymmetric Pairwise Boosting (APB), initially used successfully for audio and video fingerprints [4]. APB learns (i) discriminative portions of PR as well as (ii) thresholds to quantize each portions to a 1-bit element: the concatenation of such bits forms a compact fingerprint which can be efficiently stored and matched for fast PR processing.

In details, the main contributions of this work can be summarized as follows:

- We introduce a PR binary fingerprint based on the APB algorithm. To ensure reproducible research, our implementation is made publicly available¹. Moreover, the data used for training the proposed fingerprinting technique come from open datasets, detailed in [5] and [6].
- The proposed fingerprinting method requires less than 1% of the memory used by state-of-the-art methods, with comparable fingerprinting accuracy.
- We evaluate the performance of our methodology against leading PR fingerprinting techniques. Our focus includes clustering metrics and memory requirements.

The rest of the paper is organized as follows: Section II discusses prior research on PR and MAC de-randomization, as well as the APB algorithm to create compact fingerprints. Section III outlines the proposed fingerprinting method, the proposed filters, as well as the fingerprint-matching pipeline. Section IV details the binary data pre-processing. Section V discusses experimental results and presents a comparison with state-of-the-art techniques, while Section VI concludes the paper with final remarks and future research directions.

¹Code Repository: github.com/GiovanniBaccichet/CompactProbes

II. RELATED WORK

The study of PR frames in Wi-Fi networks has become a well-investigated research area due to the significant privacy and security implications associated with these frames. PRs, used to discover available networks in the transmission range of the devices, contain MAC addresses that can be potentially used to track devices. To address these privacy concerns, manufacturers and Operating System (OS) developers have implemented several countermeasures. These include randomizing the source address, minimizing metadata in PR frames (e.g., obscuring the Preferred Network List (PNL) or eliminating non-essential fields), and periodically rotating frame content between probe bursts. This developments have sparked active research into PRs fingerprinting methodologies for applications such as network optimization, security monitoring, and user analytics. Early work by Vanhoef et al. [7] explored the use of temporal and spatial patterns in PR frames. They identified that, despite the MAC randomization, devices often exhibit unique patterns in terms of SSID lists, inter-packet timing, and sequence numbers, which can be leveraged to link multiple PR to the same device. Similarly, Matte et al. [8] proposed a novel attack method that leveraged timing observations of PR frames. They developed an Inter-Frame Arrival Time (IFAT) signature to distinguish devices based on the rate at which they sent these requests. Recent research by Pintor et al. [9] provided a comprehensive analysis of IE fingerprinting using Density-Based Spatial Clustering of Applications with Noise (DBSCAN) clustering, yielding promising results in a controlled laboratory setting. However, it highlighted a significant limitation: the misclassification of devices that share the same device model due to nearly identical IE fields.

In 2024, Baccichet et al. [6] addressed the challenge of identifying devices with the same model and OS version by utilizing multi-channel behavior patterns. While all these works focus mainly on the accuracy of PR fingerprinting, i.e., the capability to link two PR to the same device, none of them tackles the problem of compressing such fingerprints.

III. METHODOLOGY

The problem we aim to solve is the following: given a PR x_n , we seek to generate a M -dimensional binary fingerprint $F(x_n) = [F_1(x_n), F_2(x_n), \dots, F_M(x_n)] \in \{-1, +1\}^M$, which serves as a robust hash for that PR and other PR frames from the same physical device. We adapt the APB algorithm for the task at hand. APB extends the AdaBoost classifier [10] for pairs of samples. Unlike AdaBoost, where each sample in the training set is assigned an individual label, APB assigns labels to pairs of samples. These labels indicate whether the pairs are matching or non-matching. The algorithm's goal is to learn a classifier that can determine if a pair of test samples, two PR frames in our case, matches or not.

Let $y_n \in \{-1, +1\}$ denote the label describing the ground truth relationship between the pair $\langle x_{a(n)}, x_{b(n)} \rangle$, where $n = 1, \dots, N$. The label y_n takes the value $+1$ if the two PRs are

Algorithm 1: Asymmetric Pairwise Boosting

Input :

- Ground truth relationships $\langle x_{a(n)}, x_{b(n)}; y_n \rangle$
- Set of filters $\mathcal{H} = \{h_1, h_2, \dots, h_B\}$
- Set of thresholds $\mathcal{T} = \{t_1, t_2, \dots, t_T\}$

Output:

- Set of $M < B$ filters $\mathcal{H}^* = \{h_{i(1)}, h_{i(2)}, \dots, h_{i(M)}\}$
- Corresponding thresholds $\mathcal{T}^* = \{t_{j(1)}, t_{j(2)}, \dots, t_{j(M)}\}$

```

1 for  $m := 1$  to  $M$  do
  // Iterate over each bitmask filter
2 for  $i := 1$  to  $B$  do
  // Iterate over each threshold
3 for  $p := 1$  to  $T$  do
  // Iterate over each pair
4 for  $n := 1$  to  $N$  do
5    $\varepsilon_{i,p} += w_n \delta(h_{i,p}(x_{a(n)}, x_{b(n)}) \neq y_n)$ 
6 end
7 end
8 end
  // Select best filter  $b_{i(m)}^*$  and best threshold  $t_{i(m)}^*$ 
9  $(i^*, p^*) = \arg \min_{i,p} \varepsilon_{i,p}$ 
  // Compute the confidence of the weak classifier
10  $c_m \triangleq \log \left( \frac{1 - \varepsilon_{i^*, p^*}}{\varepsilon_{i^*, p^*}} \right)$  // Asymmetric Weight Update
11 for  $n := 1$  to  $N$  do
12   if  $y_n = +1$  then
13     if  $h_{i^*, p^*}(x_{a(n)}, x_{b(n)}) \neq y_n$  then
14        $w_n \triangleq w_n \cdot \exp(c_m)$ 
15     end
16   end
17 end
  // Asymmetric Weight Normalization
18 for  $n := 1$  to  $N$  do
19   if  $y_n = +1$  then
20      $w_n = \frac{w_n}{\sum_{n: y_n = +1} w_n}$ 
21   end
22 end
23 return  $(b_{i(m)}^*, t_{i(m)}^*, c_m)$ 
24 end

```

matching (originating from the same device) and -1 if the frames are from different devices.

Moreover, let $\mathcal{H} = \{h_1, h_2, \dots, h_B\}$ define a set of bitmask filters. For each PR, we obtain a vector of B scalar intermediate representations $\{b_1(x_n), b_2(x_n), \dots, b_B(x_n)\}$, where each element $b_i(x_n)$ is the result obtained by filtering the PR x_n with the bitmask filter h_i .

The output of the APB algorithm consists of a set of $M < B$ selected filters F_i and corresponding thresholds t_j , such that,

$$F_i(x_n) = \begin{cases} +1 & \text{if } b_{i(m)}(x_n) > t_{j(m)}, \\ -1 & \text{otherwise.} \end{cases} \quad (1)$$

Where $i(m)$ with $m = 1, \dots, M$, denotes the index of the

filter selected during the m -th iteration, and $j^{(m)}$ the index of the corresponding threshold in the set $\mathcal{T} = \{t_1, t_2, \dots, t_T\}$.

In the Algorithm 1 intermediate representations are computed as follows:

$$h_{i,p}(x_{a(n)}, x_{b(n)}) \triangleq \xi((b_i(x_{a(n)}) - t_p)(b_i(x_{b(n)}) - t_p)) \quad (2)$$

Where ξ is defined as:

$$\xi((b(x_a) - t)(b(x_b) - t)) = \begin{cases} +1 & \text{if } b(x_{a,b}) > t, \\ -1 & \text{otherwise.} \end{cases} \quad (3)$$

Each step of the boosting algorithm selects the filter and the threshold that provide the best possible separation between matching and non-matching PRs. This involves choosing the weak classifier that minimizes the weighted error function over the set of all training PRs. The assignment of a weight to each pair of PRs is intended to emphasize the importance of misclassified pairs. Specifically, the more accurately the previously selected weak classifiers can classify a pair $\langle x_{a(n)}, x_{b(n)} \rangle$, the lower the corresponding weighting factor w_n becomes.

A. Candidate bitmask filters

The set of candidate filters contains filters of four different types (A,B,C and D). Each filter has length L , preceded by a prefix of P zeros and followed by a suffix of S zeros, such that $P + L + S = 1784$ bits and matches the size of a PR. Type A filters are characterized by the first half of non-zero bits being $+1$, and the second half being -1 . Type B filters are the complement of Type A, with the first half being -1 and the second half $+1$. In Type C filters, all non-zero bits are -1 , while in Type D, all non-zero bits are $+1$. Our objective was to replicate Haar-like features, generally used in image processing, using bitmasks. Similar to Haar-like features, our filters can be defined as the difference of the sum of the bits within specific areas of a PR covered by the bitmask. These areas can be located at any position within the PR and have a length $L \in \{4, 8, 16\}$. We used a total of 2,492 different filters, varying the position of the L filtering bits throughout the complete length of a PR. These filters were designed to select entire bytes, portions of fields, or overlapping portions of data across different fields of a PR.

B. Fingerprint Matching

The APB algorithm assigns a weight, namely *confidence*, c_m with $m = 1, \dots, M$ to each of the selected weak classifiers. Such weights are subsequently exploited to compute a weighted Hamming distance between a pair of test PRs, x_{n_1} and x_{n_2} , according to

$$H(x_{n_1}, x_{n_2}) = \sum_{m=1}^M c_m \xi_m(x_{n_1}, x_{n_2}) \quad (4)$$

Where the ξ function is described in (3) and assumes value $+1$ when both filtered PRs fall on the same side of the threshold corresponding to the selected filter, -1 otherwise.

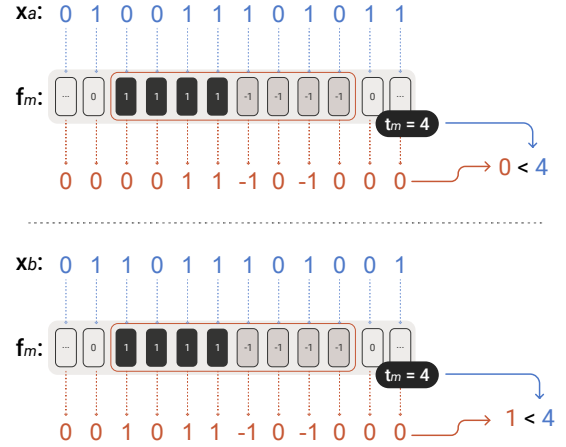

Fig. 1. Filtering process for a matching pair of PRs. The prediction is also matching: both of the filtered PRs fall on the same side of the threshold.

Then $H(x_{n_1}, x_{n_2})$ is compared to a threshold τ to determine if $\langle x_{n_1}, x_{n_2} \rangle$ is a matching pair. The value of τ is selected based on the desired trade-off between True Positive Rate (TPR) and False Positive Rate (FPR).

We note that ignoring these weights by setting $c_m = 1$ does not significantly impact the discriminative power. At the same time, this change allows to use the simple Hamming distance for matching two fingerprints, which can be efficiently performed in hardware.

For that reason, we can simplify the prediction process: two PRs having fingerprints $F(x_1)$ and $F(x_2)$ are predicted as matching ($+1$) or non-matching (-1) according to the following equation:

$$\hat{y} = \begin{cases} +1 & \text{if } \sum F(x_1) \oplus F(x_2) < \tau, \\ -1 & \text{otherwise.} \end{cases} \quad (5)$$

Where \hat{y} is the prediction (matching / non-matching pair) and $\tau \in [0, M]$. Figure 1 illustrates the matching process for one bit of the fingerprint.

IV. DATASET

We use two open datasets from previous studies, specifically [5] and [6], to ensure the reproducibility of our results. The two starting datasets are merged in a single one which includes raw PRs stored in .PCAP file format, and contain labeled information from 33 different devices (i.e., each PR is labeled with the originating device identifier). Some of these devices share the same model and OS version, simulating a realistic scenario where identical devices need to be distinguished as separate entities. The data were collected on three non-overlapping channels in the 2.4 GHz Wi-Fi band, specifically channels 1, 6, and 11. Following the IEEE 802.11 standard, we developed a custom packet dissector to extract fields from the PRs in binary format. Details on the device contained in the dataset are reported in Table I.

TABLE I
DATASET’S DEVICES DETAILS

Device Model	OS Version	No. Entries
Apple iPhone 6	iOS 12.05.02	1
Apple iPhone 7	iOS 14.6, 15.5	2
Apple iPhone 11	iOS 16.4.1(a)	4
Apple iPhone 12	iOS 14.05, 16.4.1(a)	3
Apple iPhone XR	iOS 14.6, 16.4.1(a)	3
Apple iPhone XS	iOS 14.05	1
Google Pixel 3A	Android 11	2
Huawei L21	Android 6.0	1
Huawei Honor 9	Android 9	1
Huawei P10	Android 9	1
Huawei P20	Android 10	1
OnePlus Nord	Android 11	1
Oppo Find X3 Neo	Android 13	1
Samsung Galaxy J6	Android 10	1
Samsung Galaxy M31	Android 11	1
Samsung Galaxy S4	Android 4.02.02	1
Samsung Galaxy S6	Android 7	1
Samsung Galaxy S7	Android 8	1
Samsung Galaxy S21	Android 13	1
Xiaomi Mi A2 Lite	Android 10	1
Xiaomi Redmi 4	Android 6.00.01	1
Xiaomi Redmi 5 Plus	Android 8.01	1
Xiaomi Redmi Note 7	Android 10	1
Xiaomi Redmi Note 9S	Android 11	1

A. Data Pre-Processing

We pre-process the binary PRs by considering only the IEs which have been demonstrated to be relevant by the state of the art, particularly following the insights from [9], [6], [11], and [12]. The most relevant fields for the defined use case are *HT Capabilities*, *Extended Capabilities*, and *Vendor Specific Tags*. The first two fields are used by the transmitting device to advertise its technical capabilities, while the latter carries additional information not specified by the standard.

Finally, we concatenated all the columns to generate the raw binary data to be processed by our algorithm using specific filters. After the pre-processing step, the size of each PR is equal to 223 bytes (1784 bits).

V. EXPERIMENTAL RESULTS

Our experiments are articulated in two steps: first, we identify the most interesting portions of a PR to create a compact fingerprint (i.e., selecting M filters), using the APB algorithm. This involves creating a training dataset of pairs of PRs, a testing dataset, as well as investigating the threshold τ to balance FPR and TPR. In the second phase, we assess the performance of our newly-developed binary fingerprint against state-of-the-art techniques that have proven efficient at discriminating PRs, in tasks such as counting devices in a room via clustering of PRs fingerprints. In particular, we compare our methodology with the techniques described in [9] and [6].

A. Training Data

Since the algorithm we use considers pairs of PRs and classifies them as matching or non-matching, we require both

TABLE II
TOP 16 BEST FILTER-THRESHOLD CONFIGURATIONS AND RELATIVE INFORMATION ELEMENTS ORDERED BY CONFIDENCE

Type	T	L	P	S	Information Elements
D	5	16	336	1432	Vendor Specific Tags
B	2	16	16	1752	HT Capabilities
D	3	8	24	1752	HT Capabilities
D	4	16	16	1752	HT Capabilities
D	3	8	336	1440	Len. Vendor Specific Tags
B	8	8	8	1768	HT Capabilities
D	1	8	328	1448	Vendor Specific Tags
D	1	16	352	1416	Vendor Specific Tags
A	3	16	336	1432	Vendor Specific Tags
D	2	16	240	1528	Extended Capabilities
B	1	8	216	1560	Len. Extended Capabilities
B	1	16	0	1768	HT Capabilities*
D	4	8	8	1768	HT Capabilities
D	1	8	248	1528	Extended Capabilities
D	1	16	368	1400	Vendor Specific Tags
D	7	16	0	1768	HT Capabilities*

* Length HT Capabilities + First 8 bits of HT Capabilities

a training set and a test set containing pairs of PRs, where each pair is either matching or non-matching. To achieve this, we performed the following:

- **Matching Pairs Set:** leveraging the labeled dataset, we identified 1000 unique pairs of PRs from the same devices to serve as matching examples.
- **Non-Matching Pairs Set:** We created non-matching pairs by selecting PRs from different devices. This ensured that the pairs represented distinct devices, facilitating the algorithm’s ability to differentiate between them.
- **Balancing Dataset:** We ensured that both matching and non-matching pairs were evenly represented to avoid bias and improve the algorithm’s generalization capability.
- **Dataset Partitioning:** The dataset was divided into training and test subsets (60-40) maintaining the balance of matching and non-matching pairs in each subset. The training dataset is used as input to the APB algorithm, while the test set is used to compute to evaluate performance and possibly tune matching hyperparameters.

B. Selected Filters

The filters selected by the APB algorithm are shown in Table II when $M = 16$, as an example. From 2,492 candidate filters, 16 filters and their associated thresholds are selected. As shown in Table II, these 16 filters vary in type and size. The table provides details on the filter type, relative threshold T , length L , zero prefix length P , zero suffix length S , and the IE considered by the filter.

From this analysis, it is evident that the most relevant and discriminating portion of the PR resides in the *Vendor Specific Tags* (Element ID 221). The filters are listed in the table, ordered by descending confidence c_m . There is minimal redundancy among the selected filters. Filters with longer lengths (16 or 8 bits) are predominantly chosen.

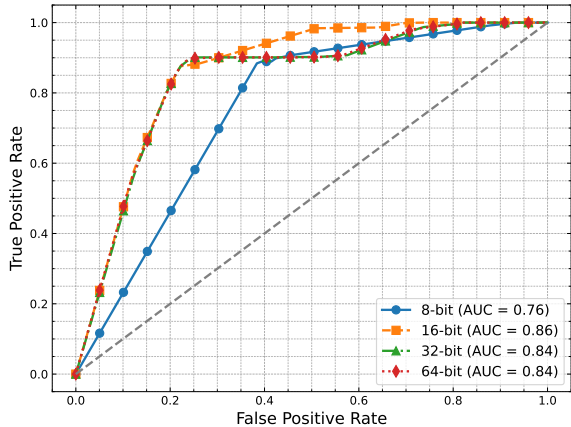

Fig. 2. ROC w/o Weighted Hamming Distance

C. Descriptor Length

We investigated the impact of the size of the descriptor on the discriminative power by varying $M = 8, 16, 32, 64$ bits. Figure 2 shows the results in terms of Receiver Operating Characteristics (ROCs) curves, using the test dataset and varying the threshold τ described in III-B from 0 to M . We then identified the optimal τ for each specific fingerprint length as the value corresponding to the point on the ROC curve closer to the top-left corner, that is the best trade-off between TPR and FPR.

From Figure 2, it can be observed that the 16-bit fingerprint slightly outperforms the other tested alternatives. We explain this behavior by noting that using a larger set of filters, and consequently a longer fingerprint, introduces more ambiguity into the fingerprint, which negatively impacts the ability to accurately predict the (non) matching status of PR pairs.

D. Clustering Results

As stated in the introduction, our secondary goal, other than obtaining a compact and fast descriptor for Wi-Fi PRs, was to compare its discriminative performance against state-of-the-art techniques for device counting. Such techniques exploit traditional clustering algorithms, such as DBSCAN, applied to IEs [12], [9] or channel behavior [6] fingerprints.

To test the performance of the proposed methods at different sizes of the device population, we adopt the following strategy: for each target population size $p = 1, \dots, P - 1$, where P is the maximum number of devices in the original dataset, we produce $d = 10$ different subsets by selecting p devices at random. We then run three different clustering algorithms (the one described in [6], the one described in [9], and the one proposed in this work) over each subset, keeping track of the final cluster Homogeneity, Completeness, and V-Measure as well as the Root Mean Square Error (RMSE) between the final number of created clusters and p .

For what concerns the proposed method, clustering is performed in an online fashion: the first PR of the dataset is

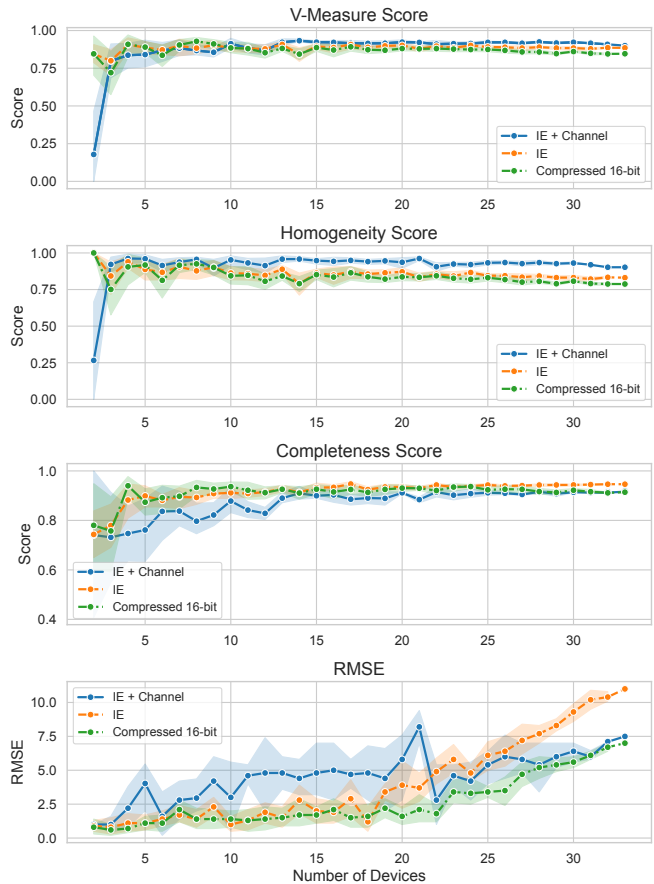

Fig. 3. Clustering Metrics of the pairwise boosting clustering

assigned to the first cluster and the corresponding fingerprint is stored as cluster identifier. For the following PRs, the computed fingerprint is compared with the existing clusters fingerprint using the Hamming distance. A new cluster is created if no existing cluster has Hamming distance smaller than τ . As expected from the evaluation done in Section V-C, the shortest fingerprint performed the worst, while the other three lengths performed comparably, with the 16-bit length being the best. To be comparable with state-of-the-art techniques, we calculated clustering metrics, such as Homogeneity, Completeness, V-Measure, and RMSE. Results for the 16, 32, and 64-bit long fingerprints are reported in Table III; we omit the 8-bit long one, as its metrics were the worst and thus not considered for the rest of the experiments.

For what concerns the methods in [9] and [6], labeled as *IE* and *IE + Channel*, respectively, in Figure 3, they work by applying DBSCAN clustering to the raw PR IEs. Since these methods require hyperparameters tuning for DBSCAN, we use the best parameters declared in the respective papers. The size of the input to such algorithms are the raw PR data, including channel information (1784 bits per PR) for the method in [6], while slightly less (1656 bits per PR for the one in [9]).

TABLE III
TABLE OF BEST FILTERS, BEST THRESHOLDS, MINIMUM ERRORS, AND CONFIDENCE

Metric	IE + Channel	IE	Fingerprint 16-bit	Fingerprint 32-bit	Fingerprint 64-bit
V-Measure (avg)	0.875	0.884	0.869	0.868	0.841
Homogeneity (avg)	0.913	0.862	0.840	0.827	0.842
Completeness (avg)	0.866	0.914	0.910	0.928	0.852
RMSE (avg)	4.446	3.871	2.543	2.299	3.202
Memory (bits / probe request)	1784	1656	16	32	64
Compression Ratio	1	1.07	111.5	55.7	27.8

The detailed results are presented in Figure 3 and are further summarized in Table III, where we provide averaged values for a comprehensive comparison. Our approach, while slightly lagging behind the state-of-the-art methods in terms of V-Measure, demonstrates a significant improvement in the accurate identification of the number of distinct devices within the dataset, showing the lowest RMSE. This indicates that our method may offer superior granularity or sensitivity in distinguishing between devices, which can be crucial in applications requiring precise device counts.

A particularly noteworthy advantage of our proposed method is its remarkable efficiency in memory usage. Our fingerprinting technique requires only about 1% of the memory compared to the techniques described in [9] and [6].

The implications of these findings suggest that while there may be a slight trade-off in identification accuracy (lowered by about 1,6% in the V-Measure), the benefits of reduced memory usage and improved device count accuracy can make our method particularly valuable in specific contexts. For instance, scenarios where memory is a critical constraint or where accurate device enumeration is prioritized over individual device identification could particularly benefit from our approach. Further research could explore optimizing the trade-offs between memory usage, identification accuracy, and other relevant performance metrics to enhance the applicability of our technique across different use cases.

VI. CONCLUSION

PR fingerprinting enables the defeat of MAC randomization, facilitating applications such as device counting, occupancy estimation, and urban flow monitoring. This paper proposes a compact yet discriminative PR fingerprint, whose structure is learned through a ML technique called APB. By leveraging a dataset of PR frames from various devices (including some of identical types), the proposed methodology identifies the discriminative parts of a PR and compresses them into a single bit using specifically learned thresholds.

The resulting binary fingerprint, whose size is fully customizable by the user, significantly reduces memory requirements for processing PR frames without compromising fingerprinting accuracy. Experiments conducted on publicly available datasets demonstrate that a fingerprint as short as 16 bits can achieve performance comparable to state-of-the-art solutions while using 100 times less memory space. To support reproducible research, the source code of our methodology is made publicly available.

ACKNOWLEDGEMENT

This study was carried out within the PRIN project COMPACT and received funding from Next Generation EU, Mission 4 Component 1, CUP: D53D23001340006.

REFERENCES

- [1] A. E. Redondi and M. Cesana, "Building up knowledge through passive WiFi probes," *Computer Communications*, vol. 117, p. 1–12, Feb. 2018. [Online]. Available: <http://dx.doi.org/10.1016/j.comcom.2017.12.012>
- [2] A. Di Luzio, A. Mei, and J. Stefa, "Mind your probes: De-anonymization of large crowds through smartphone WiFi probe requests," in *IEEE INFOCOM 2016-The 35th Annual IEEE International Conference on Computer Communications*. IEEE, 2016, pp. 1–9.
- [3] J. Tan and S.-H. G. Chan, "Efficient association of wi-fi probe requests under mac address randomization," in *IEEE INFOCOM 2021-IEEE Conference on Computer Communications*. IEEE, 2021, pp. 1–10.
- [4] D. Jang, C. D. Yoo, S. Lee, S. Kim, and T. Kalker, "Pairwise Boosted Audio Fingerprint," *IEEE Transactions on Information Forensics and Security*, vol. 4, no. 4, p. 995–1004, Dec. 2009. [Online]. Available: <http://dx.doi.org/10.1109/TIFS.2009.2034452>
- [5] L. Pintor and L. Atzori, "A dataset of labelled device Wi-Fi probe requests for MAC address de-randomization," *Computer Networks*, vol. 205, p. 108783, Mar. 2022. [Online]. Available: <http://dx.doi.org/10.1016/j.comnet.2022.108783>
- [6] G. Baccichet, C. Innamorati, A. Redondi, and M. Cesana, "MAC Address De-Randomization using Multi-Channel Sniffers and Two-Stage Clustering," in *IEEE International Symposium on Personal, Indoor and Mobile Radio Communications (PIMRC)*. IEEE, Sep. 2024.
- [7] M. Vanhoef, C. Matte, M. Cunche, L. S. Cardoso, and F. Piessens, "Why MAC Address Randomization is not Enough: An Analysis of Wi-Fi Network Discovery Mechanisms," in *Proceedings of the 11th ACM on Asia Conference on Computer and Communications Security*, ser. ASIA CCS '16. ACM, May 2016. [Online]. Available: <http://dx.doi.org/10.1145/2897845.2897883>
- [8] C. Matte, M. Cunche, F. Rousseau, and M. Vanhoef, "Defeating MAC Address Randomization Through Timing Attacks," in *Proceedings of the 9th ACM Conference on Security & Privacy in Wireless and Mobile Networks*, ser. WiSec'16. ACM, Jul. 2016. [Online]. Available: <http://dx.doi.org/10.1145/2939918.2939930>
- [9] L. Pintor and L. Atzori, "Analysis of Wi-Fi Probe Requests Towards Information Element Fingerprinting," in *GLOBECOM 2022 - 2022 IEEE Global Communications Conference*. IEEE, Dec. 2022. [Online]. Available: <http://dx.doi.org/10.1109/GLOBECOM48099.2022.10001618>
- [10] R. E. Schapire, "A brief introduction to boosting," in *Proceedings of the 16th International Joint Conference on Artificial Intelligence - Volume 2*, ser. IJCAI'99. San Francisco, CA, USA: Morgan Kaufmann Publishers Inc., 1999, p. 1401–1406.
- [11] E. Fenske, D. Brown, J. Martin, T. Mayberry, P. Ryan, and E. Rye, "Three Years Later: A Study of MAC Address Randomization In Mobile Devices And When It Succeeds," *Proceedings on Privacy Enhancing Technologies*, vol. 2021, no. 3, p. 164–181, Apr. 2021. [Online]. Available: <http://dx.doi.org/10.2478/popets-2021-0042>
- [12] M. Uras, R. Cossu, E. Ferrara, O. Bagdasar, A. Liotta, and L. Atzori, "WiFi Probes sniffing: an Artificial Intelligence based approach for MAC addresses de-randomization," in *2020 IEEE 25th International Workshop on Computer Aided Modeling and Design of Communication Links and Networks (CAMAD)*. IEEE, Sep. 2020. [Online]. Available: <http://dx.doi.org/10.1109/CAMAD50429.2020.9209257>