

Relating Quantum Tamper-Evident Encryption to Other Cryptographic Notions

Sébastien Lord
University of Ottawa
sebastien.lord@uottawa.ca

November 2024

Abstract

A quantum tamper-evident encryption scheme is a non-interactive symmetric-key encryption scheme mapping classical messages to quantum ciphertexts such that an honest recipient of a ciphertext can detect with high probability any meaningful eavesdropping. This quantum cryptographic primitive was first introduced by Gottesman in 2003. Beyond formally defining this security notion, Gottesman's work had three main contributions: showing that any quantum authentication scheme is also a tamper-evident scheme, noting that a quantum key distribution scheme can be constructed from any tamper-evident scheme, and constructing a prepare-and-measure tamper-evident scheme using only Wiesner states inspired by Shor and Preskill's proof of security for the BB84 quantum key distribution scheme.

In this work, we further our understanding of tamper-evident encryption by formally relating it to other cryptographic primitives in an information-theoretic setting. In particular, we show that tamper evidence implies encryption, answering a question left open by Gottesman, we show that it can be constructed from any encryption scheme with revocation and vice-versa, and we formalize an existing sketch of a construction of quantum money from any tamper-evident encryption scheme. These results also yield as a corollary that any scheme allowing the revocation of a message must be an encryption scheme. Finally, we show separations between tamper evidence and other primitives, notably that tamper evidence does not imply authentication and does not imply uncloneable encryption.

Contents

1	Introduction	3
1.1	The State of the Art	5
1.2	Our Contributions	5
1.2.1	Tamper Evidence, Encryption, and Authentication	6
1.2.2	Formalizing Quantum-Money from Tamper Evidence	8
1.2.3	Revocation From Tamper Evidence, and Vice-Versa	9
1.3	Open Questions	11
2	Preliminaries	13
2.1	Notation and Basic Concepts	13
2.2	Trace Distance	16
2.3	The Coherent Gentle Measurement	20
3	Defining Tamper Evidence	23
3.1	Quantum Encryption of Classical Messages Schemes	23
3.2	Tamper Evidence	26
4	Tamper Evidence Implies Encryption	30
4.1	Bad Encryption Implies Bad Tamper Evidence	31
4.2	On The Parallel Composition of AQECM Schemes	34
4.3	Good Tamper Evidence Implies Good Encryption	37
5	Quantum Money From Any Tamper-Evident Scheme	39
5.1	Defining Quantum Money	39
5.2	Gottesman’s Construction of Quantum Money	41
6	Tamper Evidence, Revocation, and Certified Deletion	49
6.1	The Syntax of Revocation and Certified Deletion Schemes	49
6.2	Defining Revocation Security	50
6.3	From Revocation to Tamper Evidence and Back	56
6.3.1	Revocation From Tamper Evidence	57
6.3.2	Tamper Evidence From Revocation	58
6.4	Revocation Implies Encryption	61
7	What Tamper Evidence Is Not	61
7.1	Tamper Evidence Does Not Imply Uncloneable Encryption	62
7.2	Tamper Evidence With A Simple Secret Sharing Scheme	66
7.3	One-Time Pad With a Tamper-Evident Encoded Key	72
7.3.1	Tamper Evidence Does Not Imply Authentication or Robustness	74
7.3.2	Tamper Evidence Does Not Imply the Encryption of Quantum States	74

1 Introduction

Consider the following scenario: Alice wants to send a classical message to Bob over a communication channel which is accessible to a malicious and eavesdropping Eve. Alice and Bob wish for Eve to never learn any information on this message. To help them, they have a shared secret key which, at the time of transmission, is unknown to Eve.

Alice and Bob can achieve their goal by using any information-theoretically secure classical symmetric-key encryption scheme, such as the one-time pad. However, if they use a scheme which produces a classical ciphertext, Eve can always make and keep a copy of it. Moreover, it is impossible for Alice and Bob to detect this eavesdropping. The secrecy of the message is then maintained if and only if Eve never learns the secret key at a later time. This general scenario is illustrated in [Figure 1](#).

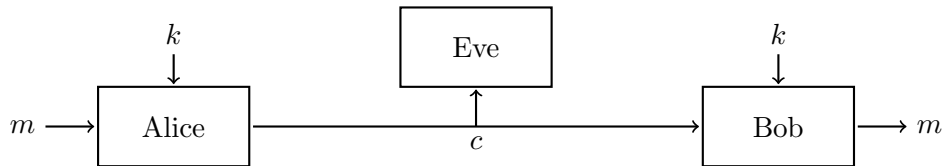

Figure 1: A classical symmetric-key encryption scenario. Alice and Bob share a classical key k which Alice uses to encrypt a classical plaintext m as a classical ciphertext c from which Bob recovers m . An eavesdropping Eve obtains, undetected, a copy of c .

In the theoretical study of a cryptographic system, it is often asserted and assumed that an eavesdropper never learns the secret key k and a proof of security is then derived in this context. In practice, however, ensuring that this assumption holds over a long period of time is a non-trivial task which falls under the umbrella of *key management*. We do not discuss this topic any further in this work, but we direct the interested reader to guidelines provided by the United States’ *National Institute of Standards and Technology* (NIST) on this topic [[Bar20](#)].

Due to the *information-disturbance principle* [[Fuc96](#)],¹ also known as the *information-disturbance trade-off*, it may be impossible for Eve to make, undetected, a copy of the ciphertext to wait to learn the secret key at a later point in time. Indeed, this principle implies that extracting previously unknown information from a quantum state must, in general, change it.

By leveraging this property of quantum mechanics, Alice and Bob can detect attempts by Eve to eavesdrop on their communication. More precisely, we can devise schemes where Bob, while decrypting a ciphertext, also determines whether he *accepts* the transmission — indicating that he did not detect any eavesdropping — or *rejects* it. This is illustrated in [Figure 2](#). If Bob accepts, then he is assured that Eve cannot learn anything about the message *even if she later learns the key*. Of course, such a method to *detect* eavesdropping

¹The information-disturbance principle is closely related to the *no-cloning principle* [[Par70](#), [Die82](#), [WZ82](#), [Ort18](#)] which states that it is, in general, impossible to make a perfect copy of an unknown quantum state. Notably, if one could make such perfect copies, then information on a state could be obtained without disturbing it by making and measuring such a copy.

does not *prevent* it. However, we can suppose that Alice and Bob may go above-and-beyond in protecting their key or implement other mitigating measures if they detect any eavesdropping.

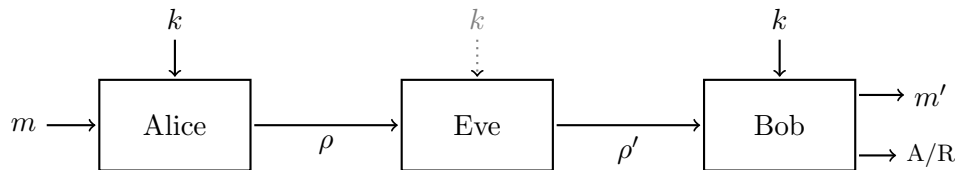

Figure 2: The communication scenario considered for tamper-evident schemes. Alice and Bob share a classical key k which Alice uses to encrypt a classical message m as a *quantum* ciphertext ρ . Eve attempts to eavesdrop on this ciphertext, possibly introducing some changes. Bob then decrypts, possibly obtaining different a message, and either accepts or rejects the transmission to indicate if he detected or not Eve’s eavesdropping. Eve only learns the key k *after* her eavesdropping attempt.

In 2003, Gottesman formalized this security notion and gave two constructions achieving it [Got03]. Following prior work [BL20], we refer to schemes achieving this notion as *tamper-evident schemes*.² Gottesman’s first construction consisted in showing that any quantum authentication scheme³ [BCG+02] was already, without any modification, a tamper-evident scheme. The second was a specific construction obtained by adapting Bennet and Brassard’s quantum key distribution scheme [BB84] and the Shor-Preskill proof of its security [SP00].

While tamper evidence and quantum key distribution are similar in the sense that they both attempt to detect an eavesdropper, they do exhibit important differences. The latter is typically interactive, does not assume a pre-share key, and produces a shared random string between Alice and Bob, while the former is non-interactive, assumes a pre-shared key, and allows Alice to send a *specific* string to Bob.

The specifics of Gottesman’s work on tamper evidence has attracted little attention in the past twenty or so years. Tamper evidence is often cited as an example of a security notion offered by quantum cryptography which cannot be achieved with only classical tools, but little work has been done to formally situate tamper evidence with respect to other quantum cryptographic primitives. This leaves the following as an open avenue of research:

*How does tamper evidence fit in the landscape of cryptographic security notions?
Which notions imply it? Which does it imply? Which are independent?*

We offer in this work multiple answers to these questions.

Organization. We complete this section by reviewing prior work on tamper evidence in Section 1.1, providing an overview of our contributions and results in Section 1.2, and highlighting a few open questions in Section 1.3.

²Gottesman originally called tamper-evident schemes “uncloneable encryption” schemes, but conceded that this may not be the proper term. Indeed, nothing *prevents* Eve from cloning the ciphertext, or at least the information it encodes. She simply cannot do without leaving evidence of her tampering.

³Quantum authentication schemes are essentially message authentication codes for quantum states.

As for the remainder, we review in detail the necessary mathematical background and notions from quantum information theory in [Section 2](#). This includes an in-depth discussion of the trace distance, a crucial notion in this work, as well as a lemma pertaining to gentle measurements. We then state the basic definitions surrounding tamper evidence in [Section 3](#). Finally, we conclude with the full details of our results in [Sections 4 to 7](#).

Acknowledgements. The author thanks Anne Broadbent for many fruitful discussions over the course of this work, in particular concerning the connections between tamper evidence, revocation, and certified deletion. The author also acknowledges support from the Natural Sciences and Engineering Research Council of Canada (NSERC) during his time at the University of Ottawa.

1.1 The State of the Art

We review the works on tamper-evident schemes and quickly summarize their results.

Gottesman’s original work [[Got03](#)] showed that every quantum authentication scheme is also a tamper-evident scheme. It also highlighted a connection with quantum key distribution (QKD) by sketching a construction of a QKD scheme from any tamper-evident scheme and by obtaining a tamper-evident scheme based on Bennet and Brassard’s QKD scheme and its analysis by Shor and Preskill. Finally, a few years later, Gottesman sketched a construction of a quantum money scheme from any tamper-evident scheme [[Got11](#)].

Leermaker and Škorić established the existence of a tamper-evident scheme which also achieved the notion of *key recycling* [[LŠ20](#)], essentially meaning that a portion of a key can be reused with little security degradation [[FS17](#)].

Finally, van der Vecht, Coiteux-Roy, and Škorić have also given a tamper-evident scheme with short keys [[vdVCRŠ22](#)].

1.2 Our Contributions

Before giving an overview of our contributions, we emphasize one place where we do *not* make a contribution: we do not define any new tamper-evident schemes, nor any other type of cryptographic schemes, “from scratch” or from first principles. Instead, we define various constructions mapping arbitrary tamper-evident schemes to other cryptographic schemes or generically constructing tamper-evident schemes from other cryptographic primitives.

Due to this level of abstraction and the wide variety of notions under consideration, we place a particular level of care in stating our various definitions and formally proving our results. We emphasize that Gottesman has already shown the unconditional existence of arbitrarily good tamper-evident schemes [[Got03](#)]. This is recorded here in [Theorem 22](#). Thus, the constructions we define and study can be instantiated and the conclusions we derive hold unconditionally.

Our contributions can be divided into four categories. We have three “positive” categories: we show that tamper evidence implies encryption, we formalize how it yields quantum money schemes, and we relate it to encryption schemes with revocation. These are developed in [Sections 4 to 6](#), respectively. We conclude this work in [Section 7](#) with our

final category where we collect various “negative” results. There, we provide counterexamples by constructing various schemes which are tamper evident but fail to achieve other properties of interest.

In what follows, we review the three positive categories and we indicate the relevant counterexamples from the fourth one as they arise.

1.2.1 Tamper Evidence, Encryption, and Authentication

Gottesman defines a tamper-evident scheme as an *encryption scheme* which *permits the honest receiver to detect meaningful eavesdropping*. We refer to this second property as the “tamper-evident requirement”. Gottesman later states the following [Got03]:

Note that [a tamper-evident scheme] by definition must also encrypt the message, so that Eve, even if she gets caught, cannot read the message until she learns the key. It is unclear whether this is an independent condition or whether it would follow from the [tamper-evident] requirement alone. (A classical message sent completely unencrypted can always be copied, but it may be possible to create partially encrypted messages which are [tamper-evident].)

Contribution. We answer this question in [Section 4](#) by showing that encryption is *not* an independent property and that *it does* follow from the tamper-evident requirement alone.

There was already some evidence pointing towards this result. Gottesman had shown that quantum authentication schemes were also, without any modification, tamper-evident schemes [Got03] and nearly concurrent work by Barnum, Crépeau, Gottesman, Smith, and Tapp had shown that any quantum authentication scheme is, without any modification, a quantum encryption scheme [BCG⁺02]. Thus, it was already known that tamper evidence and encryption were somewhat related inasmuch that they are both implied by a common cryptographic property:⁴

$$\text{Quantum Authentication} \implies (\text{Tamper Evidence} \wedge \text{Encryption of Quantum States}). \quad (1)$$

We show that a finer-grained version of the previous implication holds, namely that

$$\text{Quantum Authentication} \implies \text{Tamper Evidence} \implies \text{Encryption of Classical Messages} \quad (2)$$

and that the converses do not hold. Specifically, we show that the second implication holds in [Theorem 30](#) and we show that the converse of the first does not hold in [Section 7.3.1](#). The first implication was shown by Gottesman and the second converse trivially does not hold. We note that Gottesman did *conjecture* the existence of non-authenticating tamper-evident schemes, but did not prove this fact [Got03].

From [Equation 1](#) to [Equation 2](#), we have shifted from the encryption of *quantum states* to the more restrictive — and hence less powerful — encryption of *classical messages*, seen as a subset of quantum states. This is a necessary specification as we show in [Section 7.3.2](#) how to construct a tamper-evident scheme which does not encrypt all quantum states. Thus, a more appropriate representation of the relations between encryption, tamper-evidence, and authentication exhibited in this work is given by the Venn diagram in [Figure 3](#).

⁴These implications hold with at most a polynomial loss of security, and no loss of correctness.

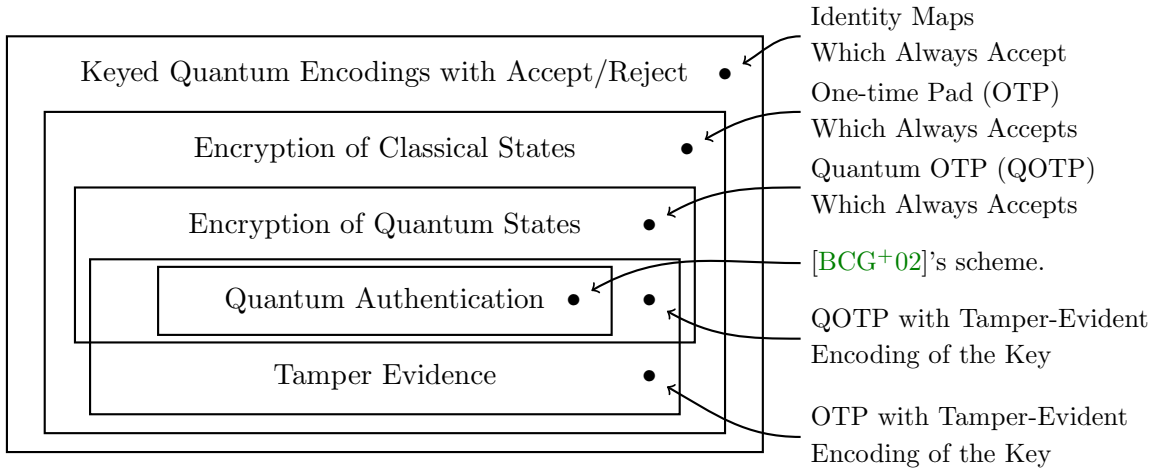

Figure 3: A Venn diagram showing the relations between quantum authentication schemes, tamper-evident schemes, and encryption schemes within all keyed quantum encoding schemes where the decoding map must also produce an accept/reject flag. Some schemes are pinpointed to illustrate that each discernable region shown here is distinct. The identity, OTP, and QOTP schemes have decoding maps augmented to always accept.

Proving that tamper evidence implies encryption. Our proof showing that tamper evidence implies encryption is similar to Barnum *et al.*'s proof that quantum authentication implies the encryption of quantum states [BCG⁺02]. We proceed in three steps.

Step 1: Show that bad encryption implies bad tamper evidence. The main novel observation underpinning our proof is that a bad encryption scheme must be a bad tamper-evident scheme (Theorem 24). Indeed, consider an encoding scheme which admits two messages whose encodings are near-perfectly distinguishable, even without knowledge of the key. By definition, such a scheme cannot be a good encryption scheme. Moreover, via a gentle measurement, the encoded states can be distinguished essentially without disturbing them. This allows an eavesdropper to obtain information on the ciphertext, and hence on the underlying message, in a way which will not be detected by the honest receiver with high probability. Such a scheme thus fails to be sufficiently tamper-evident.

Unfortunately, we cannot simply take the contrapositive of this result and be satisfied. The precise quantification we obtain is not enough to conclude via this method that good tamper-evident schemes are good encryption schemes. A bit more work is needed.

Step 2: Analyse the parallel composition of tamper-evident schemes. Next, we show that the parallel composition of tamper-evident schemes only yields a *linear* loss of security (Theorem 27). This is in contrast to the fact made explicit by Barnum *et al.* that the parallel composition of encryption schemes yields an *exponential* loss in security [BCG⁺02].

Step 3: Leverage these different rates of security degradation. We play this linear loss of security as a tamper-evident scheme against the exponential loss of security as an encryption scheme to obtain our result.

Indeed, if a good tamper-evident scheme was not a sufficiently good encryption scheme, then the repeated parallel composition of this scheme would yield a contradiction: It would

pass the threshold of being a bad encryption scheme before passing the threshold of being a bad tamper-evident scheme, contradicting our prior result.

Proving that tamper evidence does not imply authentication. To show in [Section 7.3.1](#) that tamper evidence does not imply authentication, we construct a tamper-evident scheme which makes it easy for an adversary to change the encoded message without detection. The idea is to encrypt a message m with a classical one-time pad p , and then encrypt p with a tamper-evident scheme. The overall ciphertext is then composed of two parts: the classical string $m \oplus p$ and the tamper-evident encryption of p .

Upon reception of a ciphertext from this scheme, the honest recipient can check if any eavesdropping occurred on the tamper-evident encoding of p . If none is detected, then they can be assured that an adversary is unlikely to be able to learn m even if they kept a copy of $m \oplus p$ and later learn the key used by the tamper-evident scheme. Indeed, the tamper-evident guarantee ensures that they are unlikely to learn p in this scenario.

On the other hand, the only part of the ciphertext which depends on the message — the classical string $m \oplus p$ — is sent without any additional layers of protection. This means that an adversary can pick any string e and modify this part of the ciphertext to become $(m \oplus e) \oplus p$ without being detected by the honest recipient. Indeed, the recipient will simply believe that $m \oplus e$ was the original message sent. In other words, this construction yields a tamper-evident scheme which is *malleable* because the one-time pad is itself malleable.

Other separations. As for the remaining separating examples illustrated in [Figure 3](#), we claim that the always-accepting identity maps, the always-accepting one-time pad, and the always-accepting quantum one-time pad are trivial to situate in this diagram. As for the quantum one-time pad with a tamper-evident encoded key, we claim without further proof that it can be situated with an argument analogous to the one we have just made for the classical one-time pad with a temper-evident encoded key.

1.2.2 Formalizing Quantum-Money from Tamper Evidence

Quantum money was perhaps the first widely known quantum cryptographic primitive, having been published by Wiesner in 1983 [[Wie83](#)] about a decade after it was initially conceived.⁵ In a quantum money scheme, a bank issues “quantum banknotes” which, in general, consist of a quantum state ρ_s and a classical piece of information s often understood to be the serial number of the banknote. Any user may return a banknote to the bank to have it validated to ensure that it is not a forgery. The relevant security guarantee here is that it should be infeasible for any adversary to turn one honestly produced banknote (ρ_s, s) into *two* banknotes (σ', s') and (σ'', s'') which would *both* be accepted by the bank. The basic template for the bank’s verification process is for it to maintain a database associating each public serial number s to a secret keys k_s which the bank can use to validate the quantum state ρ_s .

In this foundational work, Wiesner presented an explicit quantum money scheme and sketched an argument that it should achieve the desired security notion. A formal proof of security was presented about thirty years later [[MVW13](#)], prompted by discussions on

⁵Those interested should read Brassard’s account of the early days of quantum cryptography [[Bra05](#)].

an internet forum. During these same discussions, Gottesman sketched a way to transform any tamper-evident scheme into a quantum money scheme [Got11].

Gottesman’s idea was fairly straightforward: The bank samples a random key k , message m , and serial number s . It keeps (s, k, m) in its database and encodes the message m with the tamper-evident scheme using the key k to obtain a quantum state ρ . The bank then issues (ρ, s) as a banknote. To verify the authenticity of a supposed banknote (ρ', s') , the bank recovers the corresponding key k' and message m' from its database and decodes the state ρ' with the tamper-evident scheme using the key k' . The bank accepts the banknote if and only if the message m' is recovered *and* if it does not detect any eavesdropping. At a high-level, the security of this quantum money scheme follows from the security of the tamper-evident scheme. If the bank does not detect any eavesdropping, then a counterfeiter is highly unlikely to have obtained any information on the message, making it difficult for the counterfeiter to have produced a second valid encoding of this same message.

Contribution. We formalize Gottesman’s construction and formally prove and quantify the security of the resulting quantum money scheme in Section 5. Notably, we account for necessary technical details which were not directly addressed in their sketch.

Related counterexamples. Interestingly, we later show in Section 7 that it is *necessary* in this construction for the bank to check both that no eavesdropping has occurred *and* that the correct message is recovered. We do so by constructing two explicit counterexamples.

First, we construct in Section 7.1 tamper-evident schemes which allow an adversary given one honestly produced ciphertext to produce two states which will both decode to the original plaintext, but neither of which will pass the eavesdropping test. Here, it suffices to produce two tamper-evident encodings of the same message m with independently sampled keys and require that the overall ciphertext passes the eavesdropping check if and only if *both* encryptions of m pass their individual eavesdropping check. In particular, this implies that tamper-evident schemes need not be uncloneable encryption schemes [BL20].

For our second class of counterexamples, we construct in Section 7.2 secure tamper-evident schemes allowing an adversary given one honestly produced ciphertext to create two states which will both pass the eavesdropping check, but neither of which are likely to decode to the correct message. Our strategy is to split the plaintext with a simple group-based 2-out-of-2 classical secret sharing scheme (e.g.: [Sha79]) and then encode both of these shares with a tamper-evident scheme using independent keys. The overall ciphertext passes the eavesdropping check if at least one, but not necessarily both, encrypted shares pass their individual eavesdropping check. By splitting the shares, an adversary can create two states passing verification, but that cannot individually be used to recover the plaintext.

1.2.3 Revocation From Tamper Evidence, and Vice-Versa

An encryption scheme with revocation, or simply a *revocation scheme*, is a symmetric-key encryption scheme equipped with an additional revocation procedure. This procedure allows the recipient of a ciphertext, Bob, to return it to the sender, Alice. If Alice accepts the return *and* Bob did not yet know the key, then Alice is assured that Bob has learned no information on the plaintext and that this will remain the case *even if he later learns*

the key. Evidently, it is impossible to achieve this if the ciphertext is classical, but it does become possible by using quantum ciphertexts due to the information-disturbance principle. In general, a revocation procedure could consist in multiple rounds of classical or quantum communication between Alice and Bob. In this work however, we will only consider revocation procedures which consists of a single classical or quantum message from Bob to Alice.

Revocation schemes were first studied by Unruh [Unr15]. There, the revocation procedure consisted of Bob simply returning the quantum ciphertext followed by Alice verifying that the ciphertext state was unchanged. A few years later, Broadbent and Islam identified an important subclass of revocation schemes which they called *encryption with certified deletion* [BI20], or simply a *certified deletion scheme*. In a nutshell, a certified deletion scheme is a revocation scheme where the revocation procedure only requires a single *classical* message. In other words, Bob produces a classical bit string, *i.e.* a *certificate*, proving to Alice that he has effectively deleted the ciphertext. Broadbent and Islam also constructed a certified deletion scheme and provided a complete proof of security.⁶

Certified deletion has since become an important, promising, and fruitful area of research in quantum cryptography. Research on this topic has focused on expanding the scope of primitives for which a notion of certified deletion can be defined and achieved — *e.g.*: the works of Hiroka, Morimae, Nishimaki, and Yamakawa [HMNY21] and of Bartusek and Khurana [BK23] which consider public-key, attribute-based, and fully-homomorphic encryption schemes with certified deletion — or reducing the assumptions needed to achieve this notion, *e.g.*: Kundu and Tan’s device-independent protocol for certified deletion [KT23].

Contribution. We demonstrate in Section 6 a close relationship between tamper evidence and the notions of revocation and certified deletion. We do so in two ways.

First, we provide in Section 6.2, specifically Definition 44, an information-theoretic definition of security for revocation schemes which is similar to Gottesman’s definition of security for tamper-evident schemes. We then demonstrate that, up to a linear loss in the security quantification, this new definition is equivalent to the existing game-based definition of revocation found in the literature.

Second, we give in Section 6.3 two generic constructions relating these tamper-evidence and revocation. We describe in Section 6.3.1 a construction which transforms any tamper-evident scheme into a revocation scheme and in Section 6.3.2 a construction which transforms any revocation scheme — including any certified deletion scheme — into a tamper-evident scheme. In both of these constructions, we show that there is at most a polynomial loss of security and correctness.

Conceptually, the relationship between tamper evidence and revocation follows from the fact that we can, at a high-level, identify the roles of “revocation Bob” and “tamper-evident Eve”. To achieve either security notion, the remaining honest parties must ensure that these adversaries remain ignorant of the plaintext even if they later learn the key. To complete the comparison, it suffices to see “revocation Alice” as playing the part of both “tamper-evident Alice” while generating the ciphertext and of “tamper-evident Bob” when determining if they accept the state they receive. This is illustrated in Figure 4.

⁶Contemporary and independent work by Coiteux-Roy and Wolf [CRW19] also examined a notion and

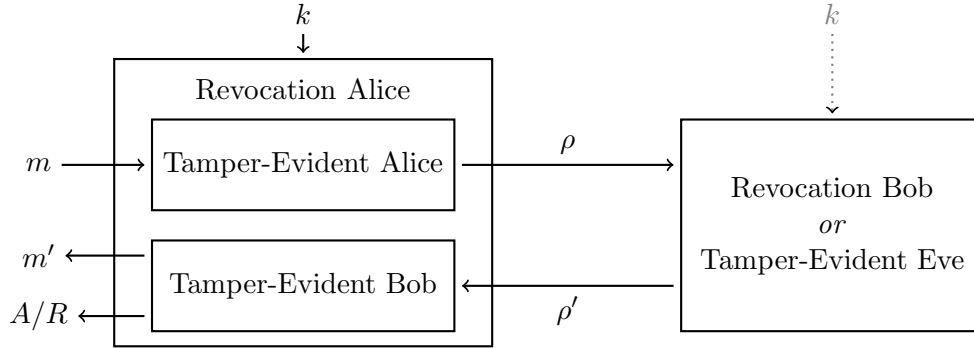

Figure 4: Conceptual identification between the parties in a tamper-evident scheme and revocation scheme. Contrast with Figure 2. Note that in the revocation scenario Alice does not output a decoded message m' and ρ' may be on a different space than ρ .

Our construction of a revocation scheme from a tamper-evident scheme is also well illustrated by Figure 4. We show that Bob returning the ciphertext unmodified and Alice checking the flag produced by the tamper-evident decryption procedure yields a secure revocation procedure.

The construction of a tamper-evident scheme from a revocation scheme is a bit more involved. The main observation we use here is that being able to prove that you have deleted the only instance of some information also implicitly proves that you were the only party in possession of this information.⁷ Hence, Bob in a tamper-evident scenario can convince himself that there was no meaningful eavesdropping by successfully executing and verifying a revocation procedure on the ciphertext by himself. At first glance, this is not quite sufficient as Bob, in a tamper-evident scheme, must also recover the message. However, if Bob executes a revocation procedure, perhaps even one from a certified deletion scheme, how can he hope to also recover the message? Has he not deleted the ciphertext? To overcome this issue, we have Bob instead execute a gentle-measurement version of the complete revocation procedure and subsequent verification where only the final accept/reject output, and not the intermediate state that would be returned, is measured.

Finally, we obtain as a direct corollary that every revocation scheme must also be an encryption scheme. This follows from the fact that tamper evidence implies encryption, that we can construct a tamper-evident scheme from any revocation scheme, and that this construction leaves both the encryption and key procedures unmodified. This is recorded in Section 6.4.

1.3 Open Questions

While our work advances the understanding of the relations between tamper evidence and other cryptographic security notions, it leaves much to be done. We highlight here a few questions which remain largely open.

protocol similar to the ones presented by Broadbent and Islam but gave no satisfactory proof of security.

⁷We thank Anne Broadbent for first making and sharing this observation.

Do our results on tamper evidence hold in a computational setting? The whole of this work is completed in the information-theoretic setting where we do not formally consider the computational costs to implement or attack cryptographic schemes. However, tamper evidence can also be studied in a setting where such computational costs are considered. A natural question then is to ask which of our results hold in such a setting where schemes and attacks must be efficiently implementable. We expect most of them to hold, and we believe most of our constructions remain efficient when applied to efficient schemes.

One notable exception is our formalization of Gottesman’s construction of a quantum money scheme in [Section 5.2](#) when the underlying tamper-evident scheme is not perfectly correct. There, we require the bank to sample key-message pairs which will always lead to a correct decryption with sufficiently high probability. It is unclear if such a sampling can always be done efficiently. However, as we discuss at the end of [Section 5.2](#), this problem can be avoided by weakening the correctness notion for quantum money schemes from one where we require *all* banknotes produced by a bank to be accepted with high probability, to one where we only require *the large majority* of banknotes to be accepted with high probability.

Can we formalize the connection between tamper evidence and quantum key distribution? Gottesman noted that a quantum key distribution scheme can be easily obtained from a tamper-evident scheme [[Got03](#)]. Indeed, have Alice encode a random string s with a random key k using a tamper-evident scheme and send the resulting quantum state to Bob. Bob then acknowledges reception of the state over an authenticated classical channel, after which Alice discloses k over this same channel. Bob can now decode and verify the quantum state with k . If Bob accepts, they can be sure that an eavesdropping Eve has essentially no information on the string s , even if Eve also learned k by listening to the authenticated channel. Moreover, Gottesman sketched how minimal changes to Bennet and Brassard’s QKD scheme [[BB84](#)] yields a tamper-evident scheme. At first glance, this construction is specific to the BB84 scheme and may not be applicable to all QKD schemes.

This state of affairs yields two open questions which we have not broached in this work:

1. Can one formally prove and quantify the security of a QKD scheme obtained from Gottesman’s generic construction based on any tamper-evident scheme?
2. Can one formulate a minimal set of conditions on QKD schemes such that satisfying these conditions ensures that it is possible to generically transform it into a tamper-evident scheme? And, if so, what is the level of security achieved by the resulting tamper-evident scheme?

We expect answering the first question to be a straightforward exercise. However, the second appears more complex to tackle.

Is there a device-independent tamper-evident scheme? A device-independent quantum cryptographic scheme is one in which the honest users need not have complete control of their quantum devices to still achieve their desired security notions. Such schemes exist for both QKD (*e.g.*: [[VV14](#)]) and certified deletion (*e.g.* [[KT23](#)]). As both of these security notions are related to tamper evidence, it would appear likely that the methods used to

attain them in a device-independent manner should also allow us to construct a device-independent tamper-evident scheme. Is this indeed the case? In particular, it is unclear if our construction of a tamper-evident scheme from any certified deletion scheme would preserve device-independence, and we are inclined to believe it would not.

2 Preliminaries

We review in [Section 2.1](#) the basic mathematical concepts used in this work, how they relate to quantum mechanics, and the notation we use. Next, in [Section 2.2](#), we examine in some detail the notion of the trace distance between two linear operators, a concept central to this work. In particular, we highlight how some well known properties of the trace distance between density operators generalize to larger classes of linear operators, something which will be necessary for us. Finally, in [Section 2.3](#), we examine the concept of a gentle measurement.

2.1 Notation and Basic Concepts

Except for some differences in notation, we generally follow Watrous [[Wat18](#)]. We assume the reader is familiar with the notion of tensor products on Hilbert spaces.

Sets, alphabets, and Hilbert spaces. Sets will generally be denote with “calligraphic” uppercase characters such as \mathcal{X} or \mathcal{M} . An *alphabet* is a non-empty finite set. All Hilbert spaces in this work are complex and finite dimensional and hence isomorphic to \mathbb{C}^n for a suitable value of $n \in \mathbb{N}$. We often use the Dirac, or “bra-ket” notation [[Dir39](#)], to denote the elements of a vector space and their duals, *i.e.*: the dual of a vector $|\psi\rangle$ is $|\psi\rangle^\dagger = \langle\psi|$. For any alphabet \mathcal{A} , we let $\mathbb{C}^{\mathcal{A}}$ be a Hilbert space which admits the set $\{|a\rangle : a \in \mathcal{A}\}$ as an orthonormal basis and we call this distinguished basis the *computational basis* of the space.⁸ We will typically denote Hilbert spaces using a sans-serif font, such as \mathbb{H} , and moreover aim to systematically match symbols between alphabets and Hilbert spaces constructed from them, for example $\mathbb{X} = \mathbb{C}^{\mathcal{X}}$.

Unless otherwise specified, we take the norm on a Hilbert space to be to the square root of the inner-product of an element with itself: $\| |\psi\rangle \| = \sqrt{\langle\psi|\psi\rangle}$.

We identify \mathbb{C} with $\mathbb{C}^{\mathcal{S}}$ for any set \mathcal{S} composed of a single element. A common example is $\mathbb{C} = \mathbb{C}^{\{\varepsilon\}}$ where $\varepsilon \in \{0, 1\}^0$ is the unique bit string of length 0. Note that we will distinguish between the numbers $0, 1 \in \mathbb{N}$ and the symbols 0 and 1 used to denote the states of a classical bit.⁹

Operators on Hilbert spaces, their adjoints, and the trace. Let \mathbb{H} and \mathbb{H}' be Hilbert spaces. We denote the set of linear operators whose domain and codomain are \mathbb{H} and \mathbb{H}' ,

⁸More formally, we take $\mathbb{C}^{\mathcal{A}}$ to be the set of all maps $f : \mathcal{A} \rightarrow \mathbb{C}$ equipped with the usual point-wise addition, *i.e.*: $(f + g)(a) = f(a) + g(a)$, the usual scalar multiplication, *i.e.* $(c \cdot f)(a) = c \cdot f(a)$, and the inner product $(f, g) \mapsto \sum_{a \in \mathcal{A}} f(a)^\dagger \cdot g(a)$ where c^\dagger denotes the complex conjugate of c . For all $a \in \mathcal{A}$, we identify the element $|a\rangle$ with the map taking a to 1 and all other elements of \mathcal{A} to 0. See [[Wat18](#), Sec. 1.1.1] for more details on this construction. The details of this construction are never explicitly used in this work.

⁹In some edge cases not explicitly used in this work, this distinction can avoid some notational collisions.

respectively, by $\mathcal{L}(\mathbf{H}, \mathbf{H}')$ and we let $\mathcal{U}(\mathbf{H}, \mathbf{H}') \subseteq \mathcal{L}(\mathbf{H}, \mathbf{H}')$ denote the subset of these operators which are *isometries*, i.e.: those which preserve the norm. If $\mathbf{H}' = \mathbf{H}$, we abbreviate these notations to $\mathcal{L}(\mathbf{H})$ and $\mathcal{U}(\mathbf{H})$, respectively. Thus, $\mathcal{U}(\mathbf{H})$ is the set of *unitary* operators on \mathbf{H} .

The identity map on a Hilbert space \mathbf{H} is denoted $I_{\mathbf{H}}$ and is unitary. For any linear operator $L \in \mathcal{L}(\mathbf{H}, \mathbf{H}')$, we define its *adjoint*, denoted L^\dagger , as the unique element of $\mathcal{L}(\mathbf{H}', \mathbf{H})$ satisfying $(L^\dagger |a\rangle)^\dagger |b\rangle = \langle a|L|b\rangle$ for all $|a\rangle \in \mathbf{H}'$ and $|b\rangle \in \mathbf{H}$. For any Hilbert space \mathbf{H} , the *trace* $\text{Tr}_{\mathbf{H}} : \mathcal{L}(\mathbf{H}) \rightarrow \mathbb{C}$ is the unique linear map such that $\text{Tr}_{\mathbf{H}}(|\psi\rangle\langle\phi|) = \langle\phi|\psi\rangle$ for all elements $|\psi\rangle, |\phi\rangle \in \mathbf{H}$. The trace is *cyclical*: $\text{Tr}_{\mathbf{C}}(ABC) = \text{Tr}_{\mathbf{A}}(BCA) = \text{Tr}_{\mathbf{B}}(CAB)$ for any linear operators $A \in \mathcal{L}(\mathbf{A}, \mathbf{C})$, $B \in \mathcal{L}(\mathbf{B}, \mathbf{A})$, and $C \in \mathcal{L}(\mathbf{C}, \mathbf{B})$ and that it also satisfies $\text{Tr}_{\mathbf{H}}(L) = \sum_{i \in \mathcal{J}} \langle b_j | L | b_j \rangle$ for any $L \in \mathcal{L}(\mathbf{H})$ and any orthonormal basis $\{|b_j\rangle\}_{j \in \mathcal{J}}$ for \mathbf{H} .

A linear operator $X \in \mathcal{L}(\mathbf{H})$ is said to be *positive semidefinite* if there exists a linear operator $Y \in \mathcal{L}(\mathbf{H})$ such that $X = Y^\dagger Y$. This implies that $\langle\psi|X|\psi\rangle$ is a real non-negative number for any element $|\psi\rangle \in \mathbf{H}$. We let $\text{Pos}(\mathbf{H})$ denote the set of all positive operators on \mathbf{H} . We let $\mathcal{D}(\mathbf{H})$ denote the set of *density* operators, which is to say positive semidefinite operators with a trace of one. We also define $\mathcal{D}_\bullet(\mathbf{H})$ be the set of *subnormalized density operators*, which is to say positive semidefinite operators whose trace is an element of the real interval $[0, 1]$. Finally, an operator $X \in \mathcal{L}(\mathbf{H})$ is *Hermitian* if it is self-adjoint, which is to say that $X^\dagger = X$. We denote the set of Hermitian operators on \mathbf{H} by $\text{Herm}(\mathbf{H})$. Every Hermitian operator X admits a *square root* \sqrt{X} which is the unique positive semidefinite operator satisfying $\sqrt{X}\sqrt{X} = X$.

Thus, for any Hilbert space \mathbf{H} we have the inclusions

$$\mathcal{D}(\mathbf{H}) \subseteq \mathcal{D}_\bullet(\mathbf{H}) \subseteq \text{Pos}(\mathbf{H}) \subseteq \text{Herm}(\mathbf{H}) \subseteq \mathcal{L}(\mathbf{H}) \quad \text{and} \quad \mathcal{U}(\mathbf{H}) \subseteq \mathcal{L}(\mathbf{H}). \quad (3)$$

Channels. We will be interested in a class of linear maps taking linear operators to linear operators, namely *channels*. These are completely positive and trace-preserving linear maps $\Phi : \mathcal{L}(\mathbf{H}) \rightarrow \mathcal{L}(\mathbf{H}')$ for Hilbert spaces \mathbf{H} and \mathbf{H}' . By *completely positive*, we mean that for any Hilbert space \mathbf{Z} the map $\Phi \otimes \text{Id}_{\mathbf{Z}}$ — where $\text{Id}_{\mathbf{Z}}$ is the identity on $\mathcal{L}(\mathbf{Z})$ — maps positive operators to positive operators, i.e.: $(\Phi \otimes \text{Id}_{\mathbf{Z}})(\text{Pos}(\mathbf{H} \otimes \mathbf{Z})) \subseteq \text{Pos}(\mathbf{H}' \otimes \mathbf{Z})$. By *trace preserving*, we mean that $\text{Tr}_{\mathbf{H}'}(\Phi(L)) = \text{Tr}_{\mathbf{H}}(L)$ for all $L \in \mathcal{L}(\mathbf{H})$, i.e.: $\text{Tr}_{\mathbf{H}'} \circ \Phi = \text{Tr}_{\mathbf{H}}$. The set of all channels with domain $\mathcal{L}(\mathbf{H})$ and codomain $\mathcal{L}(\mathbf{H}')$ is denoted $\text{Ch}(\mathbf{H}, \mathbf{H}')$. Note that channels map density operators to density operators.

The trace $\text{Tr}_{\mathbf{H}} : \mathcal{L}(\mathbf{H}) \rightarrow \mathbb{C}$ and conjugation $L \mapsto VLV^\dagger$ by any isometry $V \in \mathcal{L}(\mathbf{H}, \mathbf{H}')$ are channels, as well as any composition or tensor product of two channels. These observations are sufficient to characterize and construct *all* channels [Wat18, Cor. 2.27].

Measurements and swap channels. Let \mathcal{A} be an alphabet. A *measurement* on a Hilbert space \mathbf{H} with outcomes in \mathcal{A} is a map $\mu : \mathcal{A} \rightarrow \text{Pos}(\mathbf{H})$ such that $\sum_{a \in \mathcal{A}} \mu(a) = I_{\mathbf{H}}$. This yields a channel $\text{Ms}(\mu) : \mathcal{L}(\mathbf{H}) \rightarrow \mathcal{L}(\mathbb{C}^{\mathcal{A}})$ defined by $L \mapsto \sum_{a \in \mathcal{A}} \text{Tr}(\mu(a)L) \cdot |a\rangle\langle a|$.¹⁰

For any alphabet \mathcal{X} , we define the channel $\Delta_{\mathcal{X}} : \mathcal{L}(\mathbb{C}^{\mathcal{X}}) \rightarrow \mathcal{L}(\mathbb{C}^{\mathcal{X}})$ by

$$\rho \mapsto \sum_{x \in \mathcal{X}} |x\rangle\langle x| \rho |x\rangle\langle x| = \sum_{x \in \mathcal{X}} \langle x | \rho | x \rangle \cdot |x\rangle\langle x| = \sum_{x \in \mathcal{X}} \text{Tr}(|x\rangle\langle x| \rho) \cdot |x\rangle\langle x| \quad (4)$$

¹⁰From our prior characterization, the fact that this is a channel follows by composing conjugation by the isometry $\sum_{a \in \mathcal{A}} \sqrt{\mu(a)} \otimes |a\rangle \in \mathcal{L}(\mathbf{H}, \mathbf{H} \otimes \mathbb{C}^{\mathcal{A}})$ with the channel $(\text{Tr}_{\mathbf{H}} \otimes \text{Id}_{\mathbb{C}^{\mathcal{A}}}) : \mathcal{L}(\mathbf{H} \otimes \mathbb{C}^{\mathcal{A}}) \rightarrow \mathcal{L}(\mathbb{C}^{\mathcal{A}})$.

often called the *completely dephasing channel*. It coincides with a measurement in the computational basis, *i.e.*: $\Delta_{\mathcal{X}} = \text{Ms}(\mu_{\text{c.b.}})$ where $\mu_{\text{c.b.}} : \mathcal{X} \rightarrow \text{Pos}(X)$ defined by $x \mapsto |x\rangle\langle x|$.

Finally, we define “swap” channels which reorder the Hilbert spaces of their domains. Let H_1, \dots, H_n be a sequence of n Hilbert spaces and let $\pi : \{1, \dots, n\} \rightarrow \{1, \dots, n\}$ be a permutation. Then, $\text{Swap}_{\pi}^{(H_1, \dots, H_n)} : \mathcal{L}(H_1 \otimes \dots \otimes H_n) \rightarrow \mathcal{L}(H_{\pi(1)} \otimes \dots \otimes H_{\pi(n)})$ is the channel which maps any simple tensor $|h_1\rangle\langle h_1| \otimes \dots \otimes |h_n\rangle\langle h_n|$ to $|h_{\pi(1)}\rangle\langle h_{\pi(1)}| \otimes \dots \otimes |h_{\pi(n)}\rangle\langle h_{\pi(n)}|$ and extends linearly to all other elements. In practice, we will denote the permutation π with the “one-line” notation. For example, $\text{Swap}_{(2,3,1)}^{(H, H', H')}$ maps $\mathcal{L}(H \otimes H' \otimes H')$ to $\mathcal{L}(H'' \otimes H \otimes H')$.

Quantum mechanics. How is this prior mathematical machinery relevant to quantum mechanics? Quantum mechanics asserts that every quantum system is associated to a Hilbert space of non-zero dimension called its *state space*. At any given moment, the state of a quantum system whose state space is H is described by a density operator $\rho \in \mathcal{D}(H)$ on this space. Any action on a quantum system is described by a channel Φ and the state of the system after the action is given by $\Phi(\rho)$ if the state prior to the action was ρ . Finally, the joint state space of two quantum systems when the first system has state space H and the second H' is the tensor product $H \otimes H'$. Note that every unit vector $|\psi\rangle \in H$ yields a density operator $|\psi\rangle\langle\psi| \in \mathcal{D}(H)$.

A measurement $\mu : \mathcal{A} \rightarrow \text{Pos}(H)$, and the channel $\text{Ms}(\mu)$ it yields, models an observation of a quantum system which provides classical information. More specifically, this measurement is applied to a state $\rho \in \mathcal{D}(\mathbb{C}^A)$, the outcome $a \in \mathcal{A}$ is obtained with probability $\text{Tr}(\mu(a)\rho)$, destroying the state ρ and leaving a new system in the state $|a\rangle\langle a|$ to record this outcome. In particular, the cyclicity of the trace implies that measuring a state $\rho \in \mathcal{D}(\mathbb{C}^A)$ in the computational basis yields outcome $a \in \mathcal{A}$ with probability $\text{Tr}(|a\rangle\langle a| \rho) = \langle a | \rho | a \rangle$.

For more details, the reader is directed to the textbooks of Nielsen and Chuang [NC10] and Watrous [Wat18] and the references therein.

Markov’s inequality. We recall Markov’s inequality (*e.g.*: [Bil95]). This is a concentration inequality which gives an upper bound on the probability that a non-negative random variable exceeds a given threshold in terms of the expectation of this random variable.

Theorem 1. Let X be a random variable distributed on the non-negative reals \mathbb{R}_0^+ . Then, for any strictly positive $\alpha \in \mathbb{R}^+$, we have that

$$\Pr[X \geq \alpha] \leq \frac{\mathbb{E}(X)}{\alpha} \quad \text{and} \quad \Pr[X < \alpha] \geq 1 - \frac{\mathbb{E}(X)}{\alpha}. \quad (5)$$

The following can be seen as an analogue to Markov’s inequality if we can also assume that X almost always falls in an interval $[0, \beta]$.

Lemma 2. Let X be a random variable distributed on \mathbb{R}_0^+ and let $\beta \in \mathbb{R}_0^+$ be such that $\Pr[0 \leq X \leq \beta] = 1$. Then, for any strictly positive $\alpha \in \mathbb{R}^+$ satisfying $\alpha < \beta$ we have that

$$\Pr[X > \alpha] \geq \frac{\mathbb{E}(X) - \alpha}{\beta - \alpha} \quad \text{and} \quad \Pr[X \leq \alpha] \leq 1 - \frac{\mathbb{E}(X) - \alpha}{\beta - \alpha}. \quad (6)$$

Proof. Since $\Pr[X > \beta] = 0$, we have that

$$\begin{aligned} \mathbb{E}(X) &\leq \beta \cdot \Pr[X > \alpha] + \alpha \cdot \Pr[X \leq \alpha] \\ &= \beta \cdot \Pr[X > \alpha] + \alpha \cdot (1 - \Pr[X > \alpha]) \\ &= \alpha + \Pr[X > \alpha] \cdot (\beta - \alpha) \end{aligned} \tag{7}$$

which yields the first equation. Noting that $\Pr[X \leq \alpha] = 1 - \Pr[X > \alpha]$ then yields the second. \square

Final miscellaneous conventions. We freely identify \mathbb{C} with $\mathcal{L}(\mathbb{C})$ in this work, as well as \mathbb{H} , $\mathbb{C} \otimes \mathbb{H}$, and $\mathbb{H} \otimes \mathbb{C}$ for any Hilbert space \mathbb{H} .

To lighten notation when there is no risk of confusion, we may identify an element of an alphabet $a \in \mathcal{A}$ with the corresponding density operator $|a\rangle\langle a| \in \mathcal{D}(\mathbb{C}^{\mathcal{A}})$. For example, if $\Phi : \mathcal{L}(\mathbb{C}^{\mathcal{A}}) \rightarrow \mathbb{H}$ is a channel, we may write $\Phi(a - a')$ instead of $\Phi(|a\rangle\langle a| - |a'\rangle\langle a'|)$.

We emphasize that an empty quantum system has \mathbb{C} as its state space and that there is a unique density operator on this space, namely 1. By identifying \mathbb{C} with $\mathbb{C}^{\{\varepsilon\}}$ — as previously discussed — and using the previous convention, we can also denote the state of an empty quantum system as ε .

When convenient, we may treat a density operator $\rho \in \mathcal{D}(\mathbb{C}^{\mathcal{A}})$ as a random variable on the set \mathcal{A} where the probability of sampling $a \in \mathcal{A}$ from ρ is given by $\text{Tr}(|a\rangle\langle a| \rho)$. In other words, $a \leftarrow \rho$ means that a is sampled by measuring ρ in the computational basis. In particular, if $A : \mathbb{C} \rightarrow \mathcal{L}(\mathbb{C}^{\mathcal{A}})$ is a channel, then $a \leftarrow A(\varepsilon)$ means that a is sampled from the set \mathcal{A} by measuring in the computational basis the output of A on the empty input.

Finally, we occasionally refer to a quantum system as a *register*, and to any quantum system with states space $\mathbb{C}^{\{0,1\}}$ as a *qubit*, the quantum analogue of a bit.

2.2 Trace Distance

This work will make extensive use of the trace distance between linear operators and so we review here its definition, some related basic facts, as well as a few simple — but less well known — technical properties.

First, recall that the trace distance between two linear operators $A, B \in \mathcal{L}(\mathbb{H})$ is defined to be half the Schatten 1-norm of their difference:

$$\frac{1}{2} \|A - B\|_1 = \frac{1}{2} \text{Tr} \sqrt{(A - B)^\dagger (A - B)}. \tag{8}$$

It is a metric on the space of linear operators. In particular it satisfies the triangle inequality. Moreover, for pairs of density operators, its value is between zero and one.

The importance of the trace distance in quantum information theory comes from the fact that it is an appropriate “operational” measure of the distance between quantum states. Indeed, suppose a party is presented uniformly at random with one of two quantum systems whose states are described by two density operators $\rho_0, \rho_1 \in \mathcal{D}(\mathbb{H})$. Then, it can be shown that the party can correctly determine with which system it was presented with a probability of at most $\frac{1}{2} (1 + \frac{1}{2} \|\rho_0 - \rho_1\|_1)$ [FdG99, Prop. 1]¹¹, a value which ranges from one half to

¹¹Note that Fuchs and van de Graaf consider in their proposition the probability of error when trying to distinguish between ρ_0 and ρ_1 , while we consider the probability of success.

one as the trace distance ranges from zero to one. Standard proofs of this fact can be found in many textbooks (e.g.: [NC10, Sec. 9.2.1]) and we will offer our own, for a slightly more general setting, shortly in [Lemma 3](#).

Before, however, we recall the following two other facts concerning the trace distance:

- The trace distance is contractive under the action of channels. More formally, we mean that for any linear operators $A, B \in \mathcal{L}(\mathbf{H})$ and any channel Φ whose domain is $\mathcal{L}(\mathbf{H})$, it holds that $\frac{1}{2}\|\Phi(A) - \Phi(B)\|_1 \leq \frac{1}{2}\|A - B\|_1$. *Operationally, this implies that applying channels cannot increase the distinguishability of two quantum systems.*
- The trace distance is invariant under conjugation by isometries. More formally, we mean that for any isometry $V \in \mathcal{U}(\mathbf{H}, \mathbf{H}')$ and any linear operators $A, B \in \mathcal{L}(\mathbf{H})$ it holds that $\frac{1}{2}\|VAV^\dagger - VB V^\dagger\|_1 = \frac{1}{2}\|A - B\|_1$.

As mentioned, the trace distance between two density operators is essentially a measure of how well quantum systems whose states are represented by these density operators can be distinguished. For our work, it will be useful to frame this via bounds concerning channels which attempt to map one state to $|0\rangle$ and the other to $|1\rangle$. We formalize this idea below for a class of linear operators which extends beyond only density operators, including, in particular, any pair of subnormalized density operators. We give an explicit proof of this lemma as it is a slightly unorthodox way to state this result and most standard references only treat the more restrictive case considering pairs of density operators.

Lemma 3. Let $A, B \in \mathcal{L}(\mathbf{H})$ be two linear operators such that $A - B$ is Hermitian. Then, for all channels $\Phi : \mathcal{L}(\mathbf{H}) \rightarrow \mathcal{L}(\mathbb{C}^{\{0,1\}})$ we have that

$$|\langle 0 | \Phi(A - B) | 0 \rangle| + |\langle 1 | \Phi(A - B) | 1 \rangle| \leq \|A - B\|_1 \quad (9)$$

which implies that

$$\langle 0 | \Phi(A) | 0 \rangle + \langle 1 | \Phi(B) | 1 \rangle \leq \frac{\text{Tr}(A) + \text{Tr}(B)}{2} + \frac{1}{2}\|A - B\|_1. \quad (10)$$

Moreover, there exists a channel, which depends on A and B , saturating these inequalities.

We make two remarks on this lemma before giving its proof.

1. If $\rho_0, \rho_1 \in \mathcal{D}(\mathbf{H})$ are density operators, implying that $\text{Tr}(\rho) = \text{Tr}(\sigma) = 1$, then

$$\frac{\langle 0 | \Phi(\rho_0) | 0 \rangle + \langle 1 | \Phi(\rho_1) | 1 \rangle}{2} \leq \frac{1}{2} \left(1 + \frac{1}{2}\|\rho - \sigma\|_1 \right). \quad (11)$$

The left-hand side of this inequality is the success probability of a party attempting to distinguish, with the channel Φ , between the state ρ_0 (by mapping it to $|0\rangle$) and the state ρ_1 (by mapping it to $|1\rangle$) if presented with one of these states sampled uniformly randomly. The right-hand side is precisely the previously advertised upper bound on the success probability of such an attempt.

2. If $\text{Tr}(A) = \text{Tr}(B)$, then

$$|\langle 0 | \Phi(A - B) | 0 \rangle| = |\text{Tr}(A - B) - \langle 1 | \Phi(A - B) | 1 \rangle| = |\langle 1 | \Phi(A - B) | 1 \rangle| \quad (12)$$

as Φ is trace preserving. This implies that $|\langle b | \Phi(A - B) | b \rangle| \leq \frac{1}{2} \|A - B\|_1$ for both values of $b \in \{0, 1\}$. However, in the general case, such as if A and B are two subnormalized density operators with distinct traces, the right-hand side of this inequality may be too small: it may only hold that $|\langle b | \Phi(A - B) | b \rangle| \leq \|A - B\|_1$.¹² Cases like these — which we will encounter — are often omitted from standard treatments.

Proof. We first show the two inequalities and then demonstrate the existence of a saturating channel.

Define the channel $\tilde{\Phi} = \Delta_{\{0,1\}} \circ \Phi$. Then,

$$\tilde{\Phi}(A) - \tilde{\Phi}(B) = \langle 0 | \Phi(A - B) | 0 \rangle \cdot |0\rangle\langle 0| + \langle 1 | \Phi(A - B) | 1 \rangle \cdot |1\rangle\langle 1| \quad (13)$$

from which it follows, by direct computation of the relevant Schatten 1-norm, that

$$\left\| \tilde{\Phi}(A) - \tilde{\Phi}(B) \right\|_1 = |\langle 0 | \Phi(A - B) | 0 \rangle| + |\langle 1 | \Phi(A - B) | 1 \rangle|. \quad (14)$$

As the trace distance is contractive under the action of channels, we have that

$$|\langle 0 | \Phi(A - B) | 0 \rangle| + |\langle 1 | \Phi(A - B) | 1 \rangle| \leq \|A - B\|_1 \quad (15)$$

which yields the first inequality. To obtain the second inequality, we note that

$$\begin{aligned} 2 \langle 0 | \Phi(A) | 0 \rangle - \text{Tr}(A) &= 2 \langle 0 | \Phi(A) | 0 \rangle - \text{Tr} \circ \Phi(A) \\ &= 2 \langle 0 | \Phi(A) | 0 \rangle - \langle 0 | \Phi(A) | 0 \rangle - \langle 1 | \Phi(A) | 1 \rangle \\ &= \langle 0 | \Phi(A) | 0 \rangle - \langle 1 | \Phi(A) | 1 \rangle \end{aligned} \quad (16)$$

and, similarly, that $2 \langle 1 | \Phi(B) | 1 \rangle - \text{Tr}(B) = \langle 1 | \Phi(B) | 1 \rangle - \langle 0 | \Phi(B) | 0 \rangle$. Thus,

$$\begin{aligned} 2 \langle 0 | \Phi(A) | 0 \rangle + 2 \langle 1 | \Phi(B) | 1 \rangle - \text{Tr}(A + B) &= \langle 0 | \Phi(A - B) | 0 \rangle + \langle 1 | \Phi(B - A) | 1 \rangle \\ &\leq |\langle 0 | \Phi(A - B) | 0 \rangle| + |\langle 1 | \Phi(A - B) | 1 \rangle| \\ &\leq \|A - B\|_1 \end{aligned} \quad (17)$$

from which the desired result follows after simple algebraic manipulations.

We now show the existence of a channel $\Psi : \mathcal{L}(\mathbf{H}) \rightarrow \mathcal{L}(\mathbb{C}^{\{0,1\}})$ which saturates these bounds. This part of the proof follows closely the corresponding proof given by Nielsen and Chuang [NC10, Sec. 9.1.2]. Note that since $A - B$ is Hermitian by assumption, we may write

$$A - B = \sum_{j \in \mathcal{J}} \lambda_j \Pi_j = \sum_{\substack{j \in \mathcal{J} \\ \lambda_j \geq 0}} \lambda_j \Pi_j + \sum_{\substack{j \in \mathcal{J} \\ \lambda_j < 0}} \lambda_j \Pi_j \quad (18)$$

for some indexing set \mathcal{J} and where each λ_j is a real number and the Π_j 's are rank one projectors on \mathbf{H} which together sum to the identity $I_{\mathbf{H}}$.¹³ At this point, we recall an

¹²*E.g.*: Taking $\Phi = \text{Id}_{\mathbb{C}^{\{0,1\}}}$, $A = |0\rangle\langle 0|$, and $B = \frac{1}{2}A$ yields $|\langle 0 | \Phi(A - B) | 0 \rangle| = \frac{1}{2}$ and $\|A - B\|_1 = \frac{1}{2}$.

¹³This is the spectral decomposition of $A - B$ [Wat18, Th. 1.3]. The fact that the λ_j 's are strictly real, and not complex, follows from the fact that $A - B$ is Hermitian.

alternative characterization of the Schatten 1-norm of an operator, namely that it is the sum of its singular values [Wat18, Sec. 1.1]. Thus, $\|A - B\|_1 = \sum_{j \in \mathcal{J}} |\lambda_j|$. Now, let

$$P = \sum_{\substack{j \in \mathcal{J} \\ \lambda_j \geq 0}} \Pi_j \quad \text{and} \quad Q = \sum_{\substack{j \in \mathcal{J} \\ \lambda_j < 0}} \Pi_j \quad (19)$$

and note that both are positive semidefinite operators which sum to the identity. Hence, we may define the measurement $\mu : \{0, 1\} \rightarrow \text{Pos}(\mathbf{H})$ by $\mu(0) = P$ and $\mu(1) = Q$ and consider the channel $\Psi = \text{Ms}(\mu)$, *i.e.*: $\rho \mapsto \text{Tr}(P\rho) \cdot |0\rangle\langle 0| + \text{Tr}(Q\rho) \cdot |1\rangle\langle 1|$. Then,

$$\langle 0 | \Psi(A - B) | 0 \rangle = \text{Tr}(P(A - B)) = \sum_{\substack{j \in \mathcal{J} \\ \lambda_j \geq 0}} \lambda_j = \sum_{\substack{j \in \mathcal{J} \\ \lambda_j \geq 0}} |\lambda_j| \quad (20)$$

and

$$\langle 1 | \Psi(B - A) | 1 \rangle = \text{Tr}(Q(B - A)) = -\text{Tr}(Q(A - B)) = -\sum_{\substack{j \in \mathcal{J} \\ \lambda_j < 0}} \lambda_j = \sum_{\substack{j \in \mathcal{J} \\ \lambda_j < 0}} |\lambda_j| \quad (21)$$

from which it follows that

$$\begin{aligned} |\langle 0 | \Psi(A - B) | 0 \rangle| + |\langle 1 | \Psi(A - B) | 1 \rangle| &= \langle 0 | \Psi(A - B) | 0 \rangle + \langle 1 | \Psi(B - A) | 1 \rangle \\ &= \sum_{j \in \mathcal{J}} |\lambda_j| \\ &= \|A - B\|_1, \end{aligned} \quad (22)$$

which yields the desired result. \square

We finish this exposition on the trace distance with three technical lemmas giving values or bounds of this norm in particular cases.

First, we recall an explicit computation of the trace distance for certain simple cases.

Lemma 4 ([Wat18, Eq. 1.184]). Let $|\psi\rangle, |\phi\rangle$ be arbitrary vectors in a Hilbert space \mathbf{H} . Then,

$$\frac{1}{2} \|\ |\psi\rangle\langle\psi| - |\phi\rangle\langle\phi| \|_1 = \sqrt{\left(\frac{\langle\psi|\psi\rangle + \langle\phi|\phi\rangle}{2}\right)^2 - |\langle\psi|\phi\rangle|^2}. \quad (23)$$

Second, the following lemma pertains to the trace distance between multiple copies of two density operators. The proof can be found in the full version of [BCG⁺02]. Conceptually, this can be understood as giving a lower bound on the ability to distinguish between n copies of a state ρ and n copies of a state σ by attempting n times to distinguish between a single copy of ρ and a single copy of σ and taking a majority vote of the result.

Lemma 5 ([BCG⁺02]). Let $\rho, \sigma \in \mathcal{D}(\mathbf{H})$ be two density operators. Then, for all $t \in \mathbb{N}$, we have that

$$\frac{1}{2} \|\rho^{\otimes t} - \sigma^{\otimes t}\|_1 \geq 1 - 2 \exp\left(-\frac{t}{2} \left(\frac{1}{2} \|\rho - \sigma\|_1\right)^2\right) \quad (24)$$

where $\rho^{\otimes t} = \rho \otimes \rho \otimes \cdots \otimes \rho$ is the tensor product of t copies of ρ , and similarly for $\sigma^{\otimes t}$.

And, third, we give a lemma concerning the trace distance between two linear operators with a particular tensor decomposition. For completion, we provide a proof of this lemma.

Lemma 6. Let \mathcal{X} be an alphabet. For any linear operators $\{A_x\}_{x \in \mathcal{X}}, \{B_x\}_{x \in \mathcal{X}} \subseteq \mathcal{L}(\mathbf{H})$ it holds that

$$\left\| \sum_{x \in \mathcal{X}} x \otimes A_x - \sum_{x \in \mathcal{X}} x \otimes B_x \right\|_1 = \sum_{x \in \mathcal{X}} \|A_x - B_x\|_1. \quad (25)$$

Proof. First, factor the common x terms. Then, by definition, we have that

$$\begin{aligned} \left\| \sum_{x \in \mathcal{X}} x \otimes (A_x - B_x) \right\|_1 &= \text{Tr} \sqrt{\left(\sum_{x \in \mathcal{X}} x \otimes (A_x - B_x) \right)^\dagger \left(\sum_{x \in \mathcal{X}} x \otimes (A_x - B_x) \right)} \\ &= \text{Tr} \sqrt{\sum_{x \in \mathcal{X}} x \otimes (A_x - B_x)^\dagger (A_x - B_x)} \\ &= \text{Tr} \left(\sum_{x \in \mathcal{X}} x \otimes \sqrt{(A_x - B_x)^\dagger (A_x - B_x)} \right) \\ &= \sum_{x \in \mathcal{X}} \text{Tr} \left(\sqrt{(A_x - B_x)^\dagger (A_x - B_x)} \right) \\ &= \sum_{x \in \mathcal{X}} \|A_x - B_x\|_1 \end{aligned} \quad (26)$$

where the second and third equalities follow from the fact that $xx' = |x\rangle\langle x| |x'\rangle\langle x'|$ is the zero operator if $x \neq x'$ and is $x = |x\rangle\langle x|$ if $x = x'$. The fourth equality follows from the linearity of the trace, the fact that $\text{Tr}(Y \otimes Z) = \text{Tr}(Y) \cdot \text{Tr}(Z)$, and that $\text{Tr}(x) = 1$. \square

2.3 The Coherent Gentle Measurement

In general, a measurement is a destructive or at least perturbative operation on a quantum state. However, it is well known that when a particular measurement outcome is highly likely, a measurement may not disturb a state by much. Formalizations of this idea include *gentle measurements* [Win99], *coherent gentle measurements* [Wil17, Sec. 9.4], and the “almost as good as new” lemma [Aar16].

Here, we give a formalization of this idea by constructing a mapping that takes any channel Φ to its “coherent gentle measurement” counterpart $\text{CGM}(\Phi)$. This construction satisfies the following gentle measurement-like property: Suppose ρ was a state such that measuring $\Phi(\rho)$ in the computational basis yielded a particular outcome with very high probability. Then, $\text{CGM}(\Phi)(\rho)$ yields a state very close to ρ tensored with the likely measurement outcome. In other words, $\text{CGM}(\Phi)$ allows us to keep ρ and obtain the outcome of measuring $\Phi(\rho)$ in the computational basis, up to some well understood error.

Our formalization is a slight extension of an exercise in Wilde’s textbook [Wil17, Ex. 9.4.2]. Our result is directly applicable to all channels instead of only measurements, yields a well defined map instead of only providing a proof of existence, and is applicable to all positive semidefinite operators, not only density operators.

We will proceed in two steps. We first define the map $\Phi \mapsto \text{CGM}(\Phi)$ and then we prove the it map posses the desired properties. First, however, we recall the following theorem which states the existence of a one-to-one correspondence between measurements and a certain class of channels.

Theorem 7 ([Wat18, Th. 2.37]). Let \mathcal{A} be an alphabet and $\Phi : \mathcal{L}(\mathbb{H}) \rightarrow \mathcal{L}(\mathbb{C}^{\mathcal{A}})$ be a channel. Then, there exists a unique measurement $\mu_\Phi : \mathcal{A} \rightarrow \text{Pos}(\mathbb{H})$ satisfying

$$\Delta_{\mathcal{A}} \circ \Phi = \text{Ms}(\mu_\Phi). \quad (27)$$

Definition 8. Let \mathbb{X} be a Hilbert space and \mathcal{Y} be an alphabet. The *coherent gentle measurement* map $\text{CGM} : \text{Ch}(\mathbb{X}, \mathbb{C}^{\mathcal{Y}}) \rightarrow \text{Ch}(\mathbb{X}, \mathbb{X} \otimes \mathbb{C}^{\mathcal{Y}})$ is defined by

$$\Phi \mapsto \left[\rho \mapsto \left(\sum_{y \in \mathcal{Y}} \sqrt{\mu_\Phi(y)} \otimes |y\rangle \right) \rho \left(\sum_{y \in \mathcal{Y}} \sqrt{\mu_\Phi(y)}^\dagger \otimes \langle y| \right) \right] \quad (28)$$

where $\mu_\Phi : \mathcal{Y} \rightarrow \text{Pos}(\mathbb{X})$ is the unique measurement satisfying $\Delta_{\mathcal{Y}} \circ \Phi = \text{Ms}(\mu_\Phi)$.

Remark 9. Definition 8 asserts that CGM maps channels to *channels*. This needs to be shown. To show that $\text{CGM}(\Phi)$ is a channel, it suffices to show that $V = \sum_{y \in \mathcal{Y}} \sqrt{\mu(y)} \otimes |y\rangle$ is an isometry in $\mathcal{U}(\mathbb{X}, \mathbb{X} \otimes \mathbb{Y})$. This follows from the fact that

$$V^\dagger V = \sum_{y, y' \in \mathcal{Y}} \left(\sqrt{\mu(y)}^\dagger \otimes \langle y| \right) \left(\sqrt{\mu(y')} \otimes |y'\rangle \right) = \sum_{y \in \mathcal{Y}} \mu(y) = I_{\mathbb{X}} \quad (29)$$

where we recall that $\sqrt{\mu(y)}^\dagger = \sqrt{\mu(y)}$ since $\sqrt{\mu(y)}$ is positive and hence self-adjoint. By the same token, we can replace the $\sqrt{\mu(y)}^\dagger$ terms in Equation 28 with $\sqrt{\mu(y)}$, which is what we will do in practice.

The following theorem gives two properties of the coherent gentle measurement map. The first bounds the trace distance between the real output $\text{CGM}(\Phi)(\rho)$ and an “ideal” output $\rho \otimes |\tilde{y}\rangle\langle\tilde{y}|$ based on the probability that measuring $\Phi(\rho)$ in the computational basis would yield \tilde{y} as outcome. The second states that measuring the \mathbb{Y} register of either $\Phi(\rho)$ or $\text{CGM}(\Phi)(\rho)$ in the computational basis yields the same results.

Theorem 10. Let \mathbb{X} be a Hilbert space and \mathcal{Y} be an alphabet. Then, the coherent gentle measurement map $\text{CGM} : \text{Ch}(\mathbb{X}, \mathbb{C}^{\mathcal{Y}}) \rightarrow \text{Ch}(\mathbb{X}, \mathbb{X} \otimes \mathbb{C}^{\mathcal{Y}})$ given in Definition 8 satisfies the following two properties.

1. For any channel $\Phi : \mathcal{L}(\mathbb{X}) \rightarrow \mathcal{L}(\mathbb{Y})$, any positive semidefinite operator $\rho \in \text{Pos}(\mathbb{X})$, and any $y \in \mathcal{Y}$, we have that

$$\frac{1}{2} \|\text{CGM}(\Phi)(\rho) - \rho \otimes |y\rangle\langle y|\|_1 \leq \sqrt{\text{Tr}(\rho)^2 - (\langle y| \Phi(\rho) |y\rangle)^2}. \quad (30)$$

2. For any channel $\Phi : \mathcal{L}(\mathbb{X}) \rightarrow \mathcal{L}(\mathbb{Y})$, we have that

$$(\text{Tr}_{\mathbb{X}} \otimes \Delta_{\mathcal{Y}}) \circ \text{CGM}(\Phi) = \Delta_{\mathcal{Y}} \circ \Phi. \quad (31)$$

Proof. We begin by showing the second point. Let $\mu_\Phi : \mathcal{Y} \rightarrow \text{Pos}(\mathbf{X})$ be the unique measurement satisfying $\Delta_{\mathcal{Y}} \circ \Phi = \text{Ms}(\mu_\Phi)$. Then, for any linear operator $\rho \in \mathcal{L}(\mathbf{X})$ we have that

$$\begin{aligned}
& (\text{Tr}_{\mathbf{X}} \otimes \Delta_{\mathcal{Y}}) \circ \text{CGM}(\Phi)(\rho) \\
&= (\text{Tr}_{\mathbf{X}} \otimes \Delta_{\mathcal{Y}}) \left(\sum_{y, y' \in \mathcal{Y}} \sqrt{\mu_\Phi(y)} \rho \sqrt{\mu_\Phi(y')} \otimes |y\rangle\langle y'| \right) \\
&= (\text{Tr}_{\mathbf{X}} \otimes \text{Id}_{\mathcal{Y}}) \left(\sum_{\tilde{y} \in \mathcal{Y}} \sum_{y, y' \in \mathcal{Y}} \sqrt{\mu_\Phi(y)} \rho \sqrt{\mu_\Phi(y')} \otimes |\tilde{y}|y\rangle \langle y'|\tilde{y}\rangle \cdot |\tilde{y}\rangle\langle \tilde{y}| \right) \\
&= (\text{Tr}_{\mathbf{X}} \otimes \text{Id}_{\mathcal{Y}}) \left(\sum_{\tilde{y} \in \mathcal{Y}} \sqrt{\mu_\Phi(\tilde{y})} \rho \sqrt{\mu_\Phi(\tilde{y})} \otimes |\tilde{y}\rangle\langle \tilde{y}| \right) \\
&= \sum_{\tilde{y} \in \mathcal{Y}} \text{Tr}(\mu_\Phi(\tilde{y})\rho) \cdot |\tilde{y}\rangle\langle \tilde{y}| \\
&= \text{Ms}(\mu_\Phi)(\rho) \\
&= \Delta_{\mathcal{Y}} \circ \Phi(\rho)
\end{aligned} \tag{32}$$

which yields the desired result.

We now show the first point. Once again, let $\mu_\Phi : \mathcal{Y} \rightarrow \text{Pos}(\mathbf{X})$ be the unique measurement satisfying $\Delta_{\mathcal{Y}} \circ \Phi = \text{Ms}(\mu_\Phi)$ and let $V = \sum_{\tilde{y} \in \mathcal{Y}} \sqrt{\mu_\Phi(\tilde{y})} \otimes |\tilde{y}\rangle$. As $\rho \in \text{Pos}(\mathbf{X})$ is a positive operator, there is a vector $|\psi\rangle \in \mathbf{X} \otimes \mathbf{X}$ such that $\rho = (\text{Tr}_{\mathbf{X}} \otimes \text{Id}_{\mathbf{X}})(|\psi\rangle\langle\psi|)$.¹⁴ Note that $|\psi\rangle$ need not have norm one as we are not assuming that ρ is a density operator, only that it is positive semidefinite. As the trace distance is contractive under the action of channels, we have that

$$\begin{aligned}
& \frac{1}{2} \|\text{CGM}(\Phi)(\rho) - \rho \otimes |y\rangle\langle y|\|_1 \\
&= \frac{1}{2} \|(\text{Tr}_{\mathbf{X}} \otimes \text{CGM}(\Phi))(|\psi\rangle\langle\psi|) - (\text{Tr}_{\mathbf{X}} \otimes \text{Id}_{\mathbf{X} \otimes \mathcal{Y}})(|\psi\rangle\langle\psi| \otimes |y\rangle\langle y|)\|_1 \\
&\leq \frac{1}{2} \|(\text{Id}_{\mathbf{X}} \otimes \text{CGM}(\Phi))(|\psi\rangle\langle\psi|) - (|\psi\rangle\langle\psi| \otimes |y\rangle\langle y|)\|_1. \\
&= \frac{1}{2} \left\| (I_{\mathbf{X}} \otimes V) |\psi\rangle\langle\psi| (I_{\mathbf{X}} \otimes V^\dagger) - |\psi\rangle\langle\psi| \otimes |y\rangle\langle y| \right\|_1.
\end{aligned} \tag{33}$$

We can then use [Lemma 4](#) to compute this final trace distance. As V is an isometry, we have that

$$\text{Tr} \left((I_{\mathbf{X}} \otimes V) |\psi\rangle\langle\psi| (I_{\mathbf{X}} \otimes V^\dagger) \right) = \langle\psi| (I_{\mathbf{X}} \otimes V^\dagger V) |\psi\rangle = \langle\psi|\psi\rangle. \tag{34}$$

We also have that

$$\text{Tr}(|\psi\rangle\langle\psi| \otimes |y\rangle\langle y|) = \langle\psi|\psi\rangle \cdot \langle y|y\rangle = \langle\psi|\psi\rangle. \tag{35}$$

¹⁴Such a vector is known as a *purification* of ρ and is guaranteed to exist [[Wat18](#), Th. 2.20].

Further, both these quantities are also equal to $\text{Tr}(\rho)$. Thus, by [Lemma 4](#), it follows that

$$\begin{aligned} \frac{1}{2} \left\| (I_{\mathbf{X}} \otimes V) |\psi\rangle\langle\psi| (I_{\mathbf{X}} \otimes V^\dagger) - |\psi\rangle\langle\psi| \otimes |y\rangle\langle y| \right\|_1 &= \sqrt{\text{Tr}(\rho)^2 - |(\langle\psi| \otimes \langle y|) (I_{\mathbf{X}} \otimes V) |\psi\rangle|^2} \\ &= \sqrt{\text{Tr}(\rho)^2 - |\langle\psi| (I_{\mathbf{X}} \otimes \sqrt{\mu(y)}) |\psi\rangle|^2} \end{aligned} \quad (36)$$

Now, note that

$$\langle\psi| (I_{\mathbf{X}} \otimes \sqrt{\mu(y)}) |\psi\rangle = \text{Tr}_{\mathbf{X} \otimes \mathbf{X}} \left((I_{\mathbf{X}} \otimes \sqrt{\mu(y)}) |\psi\rangle\langle\psi| \right) = \text{Tr}_{\mathbf{X}} \left(\sqrt{\mu(y)} \rho \right) \quad (37)$$

and that this quantity must be real and non-negative by virtue of $I_{\mathbf{X}} \otimes \sqrt{\mu(y)}$ being a positive semidefinite operator. We now claim that $\text{Tr}_{\mathbf{X}}(\sqrt{\mu(y)} \rho) \geq \text{Tr}_{\mathbf{X}}(\mu(y) \rho)$. This is obtained by considering the spectral decomposition $\mu(\tilde{y}) = \sum_{j \in [\dim \mathbf{X}]} \lambda_j \Pi_j$ where each Π_j is a projector on orthogonal subspaces and noting that that every λ_j is real, non-negative, and no greater than one. The first two properties of these λ_j 's follow from the fact that $\mu(y) \in \text{Pos}(\mathbf{X})$ and the last from the fact that $\sum_{\tilde{y} \in \mathcal{Y}} \mu(\tilde{y}) = I_{\mathbf{X}}$. Thus, we find that $\sqrt{\mu(y)} = \sum_{j \in [\dim \mathbf{X}]} \sqrt{\lambda_j} \Pi_j$ and so

$$\text{Tr}_{\mathbf{X}} \left(\sqrt{\mu(y)} \rho \right) = \sum_{j \in [\dim \mathbf{X}]} \sqrt{\lambda_j} \text{Tr}(\Pi_j \rho) \geq \sum_{j \in [\dim \mathbf{X}]} \lambda_j \text{Tr}(\Pi_j \rho) = \text{Tr}(\mu(y) \rho). \quad (38)$$

Finally, $\text{Tr}(\mu(y) \rho) = \langle y | \text{Ms}(\mu)(\rho) | y \rangle = \langle y | \Delta_{\mathcal{Y}} \circ \Phi(\rho) | y \rangle = \langle y | \Phi(\rho) | y \rangle$. Collecting the above facts immediately yields that

$$\frac{1}{2} \|\text{CGM}(\Phi)(\rho) - \rho \otimes |y\rangle\langle y|\|_1 \leq \sqrt{\text{Tr}(\rho)^2 - (\langle y | \Phi(\rho) | y \rangle)^2} \quad (39)$$

which is the desired result. \square

3 Defining Tamper Evidence

The goal of this section is twofold. First, we formally define the main objects which we will study in this work, namely *quantum encryptions of classical messages* (QECCM) schemes and their *augmented* variants, AQECCM schemes. Second, we formalize the notion of *tamper evidence*, a property which can be possessed by augmented quantum encryption of classical messages schemes.

Recall that QECCMs and AQECCMs are keyed encoding schemes for classical messages which produce quantum states. While such schemes were implicit in the literature since at least the early 2000s, such as in Gottesman's work [\[Got03\]](#), this terminology and precise formalization was first introduced in our prior work on uncloneable encryption [\[BL20\]](#) for QECCMs, and subsequently expanded by Broadbent and Islam to AQECCMs in the course of their work on certified deletion [\[BI20\]](#).

3.1 Quantum Encryption of Classical Messages Schemes

A quantum encryption of classical messages (QECCM) scheme is a triplet of channels (K, E, D) called, respectively, the *key generation*, *encoding*, and *decoding* channels. These channels

are required to satisfy certain constraints on their domains and codomains to ensure that they are compatible with one another. Implicitly, these requirements on the domains and codomains also define two alphabets \mathcal{K} and \mathcal{M} which represent, respectively, the set of classical keys and messages for this scheme.

Definition 11. A *quantum encryption of classical messages* (QECM) scheme is a triplet of channels (K, E, D) of the form

$$K : \mathcal{L}(\mathbb{C}) \rightarrow \mathcal{L}(\mathbb{K}), \quad E : \mathcal{L}(\mathbb{K} \otimes \mathbb{M}) \rightarrow \mathcal{L}(\mathbb{C}), \quad \text{and} \quad D : \mathcal{L}(\mathbb{K} \otimes \mathbb{C}) \rightarrow \mathcal{L}(\mathbb{M}) \quad (40)$$

for Hilbert spaces \mathbb{K} , \mathbb{M} , and \mathbb{C} where, $\mathbb{K} = \mathbb{C}^{\mathcal{K}}$ and $\mathbb{M} = \mathbb{C}^{\mathcal{M}}$ for alphabets \mathcal{K} and \mathcal{M} . We call the elements of these alphabets, respectively, the *keys* and *messages* of the scheme.

To lighten notation, for every key $k \in \mathcal{K}$ we define the channels $E_k : \mathcal{L}(\mathbb{M}) \rightarrow \mathcal{L}(\mathbb{E})$ and $D_k : \mathcal{L}(\mathbb{E}) \rightarrow \mathcal{L}(\mathbb{M})$ by $\rho \mapsto E(k \otimes \rho)$ and $\rho \mapsto D(k \otimes \rho)$, respectively.

From this point on, to ease notation, whenever we talk of a “QECM scheme (K, E, D) as given in Definition 11”, we are assuming that the domains and codomains are defined and denoted exactly as in Definition 11.

We now define a quantitative notion of *correctness* for QECM schemes. In short, a QECM scheme is ϵ -correct if for every message $m \in \mathcal{M}$ the probability that it is correctly recovered by the decoding map D_k after being processed by the encoding map E_k is at least $1 - \epsilon$. Here, the probability is taken over the action of the maps E_k and D_k as well as the randomness of sampling the key $k \leftarrow K(\epsilon)$ from the key generation procedure.

Definition 12. Let $\epsilon \in \mathbb{R}$. A QECM scheme (K, E, D) as given in Definition 11 is ϵ -correct if for all messages $m \in \mathcal{M}$ we have that

$$\mathbb{E}_{k \leftarrow K(\epsilon)} \langle m | D_k \circ E_k(m) | m \rangle \geq 1 - \epsilon. \quad (41)$$

We say that a QECM scheme is *perfectly correct*, or simply *correct*, if it is 0-correct.

We emphasize that correctness for QECMs only considers *classical* messages $m \in \mathcal{M}$. A QECM need not be able to recover any arbitrary quantum state to be correct. As an example, consider the QECM with $\mathcal{M} = \{0, 1\}$ and $\mathcal{K} = \{\epsilon\}$ where the channel E_ϵ is given by $\rho \mapsto Z\rho Z^\dagger$ for the Pauli operator $Z = |0\rangle\langle 0| - |1\rangle\langle 1|$ and $D_\epsilon = \text{Id}$. A direct calculation yields $D_\epsilon \circ E_\epsilon(|+\rangle\langle +|) \neq |+\rangle\langle +|$ where $|+\rangle = \frac{1}{\sqrt{2}}(|0\rangle + |1\rangle)$. However, for both $b \in \{0, 1\}$, it holds that $D_\epsilon \circ E_\epsilon(|b\rangle\langle b|) = |b\rangle\langle b|$ and so this QECM is perfectly correct.

We now proceed to define *augmented encryption of classical messages* (AQECM) schemes. In short, an AQECM scheme is identical to a QECM scheme, with the exception that the decoding channel D produces an additional “flag” qubit as part of its output. We will denote the state space of this qubit by \mathbb{F} .

Definition 13. An *augmented encryption of classical messages* (AQECM) scheme is a triplet of channels (K, E, D) of the form

$$K : \mathcal{L}(\mathbb{C}) \rightarrow \mathcal{L}(\mathbb{K}), \quad E : \mathcal{L}(\mathbb{K} \otimes \mathbb{M}) \rightarrow \mathcal{L}(\mathbb{C}), \quad \text{and} \quad D : \mathcal{L}(\mathbb{K} \otimes \mathbb{C}) \rightarrow \mathcal{L}(\mathbb{M} \otimes \mathbb{F}) \quad (42)$$

for Hilbert space K , M , C , and F where, in particular, $K = \mathbb{C}^{\mathcal{K}}$, $M = \mathbb{C}^{\mathcal{M}}$, and $F = \mathbb{C}^{\{0,1\}}$ for alphabets \mathcal{K} and \mathcal{M} . As in [Definition 11](#), the elements of \mathcal{K} and \mathcal{M} are called the keys and messages of the scheme. From D , we also define the map $\overline{D} : \mathcal{L}(K \otimes C) \rightarrow \mathcal{L}(M)$ by

$$\rho \mapsto (I_M \otimes \langle 1|_F) D(\rho) (I_M \otimes |1\rangle_F), \quad (43)$$

which is to say that \overline{D} first applies the channel D and then “reduces” to the case where the qubit is measured to be in the 1 state, followed by discarding this qubit.

For every key $k \in \mathcal{K}$, we also define the maps $E_k : \mathcal{L}(M) \rightarrow \mathcal{L}(C)$, $D_k : \mathcal{L}(C) \rightarrow \mathcal{L}(M)$, and $\overline{D}_k : \mathcal{L}(C) \rightarrow \mathcal{L}(M)$ by $\rho \mapsto E(k \otimes \rho)$, $\rho \mapsto D(k \otimes \rho)$, and $\rho \mapsto \overline{D}(k \otimes \rho)$, respectively.

As for QECCM schemes, from this point on whenever we mention an “AQECCM scheme (K, E, D) as given in [Definition 13](#)” we are assuming that the domains and codomains are defined and denoted exactly as in [Definition 13](#).

We emphasize that the *only* difference between the syntaxes of a QECCM and an AQECCM scheme is the additional “flag” qubit in the codomain of the decoding map D .

Note that the map \overline{D} , and by extension every map \overline{D}_k , may not be a channel. Indeed, the map $\rho \mapsto \langle 1| \rho |1\rangle$ applied to the F register produced by D to obtain \overline{D} is not, in general, trace preserving. It may in fact be trace *decreasing*, i.e. $\text{Tr}(\overline{D}(\sigma)) < \text{Tr}(\sigma)$. Nonetheless, these maps will be useful mathematical tools to define and study properties of AQECCM schemes. We take a moment to look at them from a more operational perspective.

For any density operator ρ and key $k \in \mathcal{K}$, we may express $D_k(\rho)$ as

$$D_k(\rho) = \rho_{00} \otimes |0\rangle\langle 0| + \rho_{01} \otimes |0\rangle\langle 1| + \rho_{10} \otimes |1\rangle\langle 0| + \rho_{11} \otimes |1\rangle\langle 1| \quad (44)$$

where both ρ_{00} and ρ_{11} are subnormalized density operators whose traces sum to one, which is to say that $\rho_{00}, \rho_{11} \in \mathcal{D}_\bullet(M)$ and $\text{Tr}(\rho_{00}) + \text{Tr}(\rho_{11}) = 1$. If a computational basis measurement is then applied to the F register, the resulting state is given by

$$(\text{Id}_M \otimes \Delta_F) D_k(\rho) = \rho_{00} \otimes |0\rangle\langle 0| + \rho_{11} \otimes |1\rangle\langle 1|. \quad (45)$$

Then, the map \overline{D}_k simply “picks out” the ρ_{11} operator from this expression: $\overline{D}_k(\rho) = \rho_{11}$. Note that $\text{Tr}(\rho_{11})$ is precisely the probability that the measurement outputs 1. From this perspective, it is easy to see that $\overline{D}_k(\rho)$ is simply the state on the M register after application of D_k to ρ , conditioned on the F register being measured to be in the 1 state and scaled by the probability that this particular measurement outcome is produced.

The precise meaning of the flag qubit produced by the decryption map of an AQECCM scheme can and will vary by context. In general, the flag qubit is set to the 0 state if the decryption channel D_k “rejects” the input state and is set to 1 if it “accepts” it, where the precise meaning of these words depends of the context. For example, Broadbent and Islam [[BI20](#)] use this flag to study AQECCM schemes as authentication schemes for classical message which produce quantum outputs. They call these *robust AQECCM* schemes. There, a flag qubit in the state 0 is meant to indicate that noise or adversarial action changed the encoded state sufficiently that the wrong message will be recovered. In the context of tamper evidence, the flag qubit will be set to the state 0 if non-trivial eavesdropping is detected.¹⁵ Nonetheless, in all contexts we will expect an AQECCM to accept any unmodified encodings of its messages when the same key is used.

This discussion leads us to the following definition of correctness for AQECCM schemes.

¹⁵As previously discussed, we sketch later in [Section 7.3.1](#) a separation robustness and tamper evidence.

Definition 14. Let $\epsilon \in \mathbb{R}$. An AQECM scheme (K, E, D) as given in Definition 13 is ϵ -correct if for all messages $m \in \mathcal{M}$ we have that

$$\mathbb{E}_{k \leftarrow K(\epsilon)} \langle m | \overline{D}_k \circ E_k(m) | m \rangle \geq 1 - \epsilon. \quad (46)$$

Our expectation that the flag qubit should be found in the 1 state is represented in the above definition by the fact that it uses the maps \overline{D}_k and not the channels D_k .

It is intuitively clear that AQECM schemes are, as the name suggests, an augmentation of QECC schemes. The following lemma formalizes this idea by confirming that discarding the flag register F of an AQECM scheme yields a QECC scheme and that correctness is preserved through this transformation.

Lemma 15. Let (K, E, D) be an ϵ -correct AQECM scheme as given in Definition 13. Then, $(K, E, (\text{Id}_M \otimes \text{Tr}_F) \circ D)$ is a QECC scheme which is ϵ -correct.

Proof. We directly see that $(\text{Id}_M \otimes \text{Tr}_F) \circ D$ is a channel from $\mathcal{L}(K \otimes C)$ to $\mathcal{L}(M)$ and so the triplet $(K, E, (\text{Id}_M \otimes \text{Tr}_F) \circ D)$ satisfies the syntactical conditions to be a QECC. It now suffices to show that this QECC is ϵ -correct.

By recalling that $\text{Tr}_F(\rho) = \sum_{b \in \{0,1\}} \langle b | \rho | b \rangle$ and the definition of \overline{D} , for every key $k \in \mathcal{K}$ and message $m \in \mathcal{M}$ we find that

$$\begin{aligned} (\text{Id}_M \otimes \text{Tr}_F) \circ D_k \circ E_k(m) &= \sum_{b \in \{0,1\}} (I_M \otimes \langle b |) (D_k \circ E_k)(m) (I_M \otimes | b \rangle) \\ &= \overline{D}_k \circ E_k(m) + (I_M \otimes \langle 0 |) (D_k \circ E_k)(m) (I_M \otimes | 0 \rangle) \end{aligned} \quad (47)$$

from which it follows that

$$\langle m | (\text{Id}_M \otimes \text{Tr}_F) \circ D_k \circ E_k(m) | m \rangle \geq \langle m | \overline{D}_k \circ E_k(m) | m \rangle \quad (48)$$

since $(\langle m | \otimes \langle 0 |) (D_k \circ E_k)(m) (| m \rangle \otimes | 0 \rangle) \geq 0$ by virtue of $D_k \circ E_k(m)$ being a positive semidefinite operator. Thus, for all $m \in \mathcal{M}$, we have that

$$\mathbb{E}_{k \leftarrow K(\epsilon)} \langle m | (\text{Id}_M \otimes \text{Tr}_F) \circ D_k \circ E_k(m) | m \rangle \geq \mathbb{E}_{k \leftarrow K(\epsilon)} \langle m | \overline{D}_k \circ E_k(m) | m \rangle \geq 1 - \epsilon, \quad (49)$$

as the original AQECM scheme is assumed to be ϵ -correct, which is the desired result. \square

3.2 Tamper Evidence

With the notion of AQECM schemes in hand, we can now define tamper evidence.

In a nutshell, an AQECM scheme exhibits tamper evidence if the party which receives a ciphertext — the one implementing the decoding channel D — can detect any non-trivial eavesdropping. This notion was first presented by Gottesman [Got03], and we review it here. To place Gottesman's notion of tamper evidence in our AQECM framework, we proceed in two steps. We first formalize in Definition 16 *tamper attacks* against a given AQECM scheme and we then state in Definition 17 the condition that an AQECM scheme must satisfy against all tamper attacks to be considered *tamper-evident*. Up to a difference

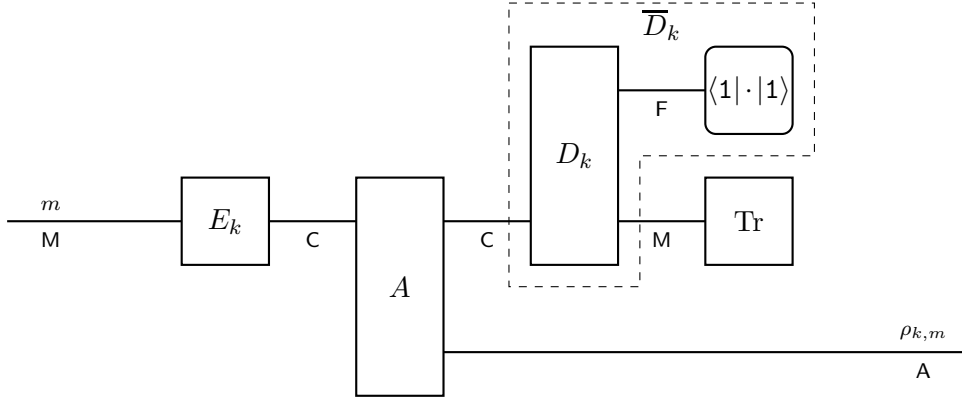

Figure 5: An AQECM scheme (K, E, D) subject to a tamper attack A , as considered in Definition 16 and Definition 17. For any given message m and key k , the final subnormalized state held by the adversary if the receiver does not detect any eavesdropping is $\rho_{k,m} \in \mathcal{D}_\bullet(\mathbf{A})$.

in presentation and some minor differences discussed later, this is the definition of tamper evidence given in [Got03].

A tamper attack can be understood as an adversary’s attempt to extract, undetected, information from an intercepted ciphertext $E_k(m) \in \mathcal{D}(\mathbf{C})$. We model any information that the adversary managed to extract as a quantum system held in a register \mathbf{A} . Moreover, we assume that the eavesdropping adversary must allow *something*, i.e. a possibly modified ciphertext, to reach the receiver. Otherwise, we may assume that the eavesdropping will necessarily be detected. Under this model, we can represent the adversary’s action as a channel which acts on the space of the encoded messages \mathbf{C} to produce a state on the space $\mathbf{C} \otimes \mathbf{A}$. This is formalized in Definition 16 and sketched in Figure 5.

Definition 16. Let (K, E, D) be an AQECM scheme as given in Definition 13. A *tamper attack* against it is a channel $A : \mathcal{L}(\mathbf{C}) \rightarrow \mathcal{L}(\mathbf{C} \otimes \mathbf{A})$ where \mathbf{A} is a Hilbert space.

We can now formalize the notion of tamper evidence. To do so will require us to consider certain subnormalized states acting on the additional Hilbert space \mathbf{A} produced by a tamper attack A . We take a moment to examine these subnormalized states in some detail before defining tamper evidence.

For any key k , message m , and tamper attack $A : \mathcal{L}(\mathbf{C}) \rightarrow \mathcal{L}(\mathbf{C} \otimes \mathbf{A})$ against an AQECM scheme (K, E, D) , we consider the operator

$$((\text{Tr}_M \circ \overline{D}_k) \otimes \text{Id}_A) \circ A \circ E_k(m), \quad (50)$$

and we note that this is a subnormalized density operator on the additional register \mathbf{A} produced by the tamper attack A , *i.e.* an element of $\mathcal{D}_\bullet(\mathbf{A})$. In Figure 5, this is the operator $\rho_{k,m}$.

Operationally, this represents the state the adversarial eavesdropper holds when the message m is sent using the key k , *conditioned* on the receiver accepting *and scaled* by the probability of this acceptance.

An AQECM scheme will be tamper evident if there is a high probability, taken over the choice of key k , that the trace distance between the subnormalized states $\rho_{k,m}$ and $\rho_{k,m'}$ is small for any two messages $m, m' \in \mathcal{M}$. This is formalized in [Definition 17](#). Recall that $((\text{Tr}_M \circ \overline{D}_k) \otimes \text{Id}_A) \circ A \circ E_k : \mathcal{L}(M) \rightarrow \mathcal{L}(A)$ is a linear operator. Hence, the difference between the image of m and m' under the action of this map can be more succinctly expressed as $((\text{Tr}_M \circ \overline{D}_k) \otimes \text{Id}_A) \circ A \circ E_k(m - m')$. We will often make use of this property to make our notation more compact.

Definition 17. Let $\delta \in \mathbb{R}$. An AQECM scheme (K, E, D) as given in [Definition 13](#) is δ -tamper-evident if for all messages $m, m' \in \mathcal{M}$ and any tamper attack A against it we have that

$$\Pr_{k \leftarrow K(\varepsilon)} \left[\frac{1}{2} \| ((\text{Tr}_M \circ \overline{D}_k) \otimes \text{Id}_A) \circ A \circ E_k(m - m') \|_1 \leq \delta \right] \geq 1 - \delta. \quad (51)$$

We know that we can interpret the trace-distance between two density operators as a measure of how well two quantum states can be distinguished. But, how should we interpret the trace distance between two *subnormalized* density operators in this context? The following lemma can be understood as stating that if the trace distance between two subnormalized density operators is small, then either the trace distance between their corresponding renormalized operators is small, or both of their traces are small.¹⁶

Lemma 18. Let $\rho_0, \rho_1 \in \mathcal{D}(A)$ be two density operators and let $t_0, t_1 \in \mathbb{R}$ be two non-negative real numbers. Then,

$$\frac{\max\{t_0, t_1\}}{2} \cdot \frac{1}{2} \|\rho_0 - \rho_1\|_1 \leq \frac{1}{2} \|t_0\rho_0 - t_1\rho_1\|_1. \quad (52)$$

Proof. First, note that $\frac{1}{2}|t_0 - t_1| \leq \frac{1}{2}\|t_0\rho_0 - t_1\rho_1\|_1$ by the fact that the trace distance is contractive under the action of any channel, including, as needed for this case, the trace. Without loss of generality, assume that $t_0 = \max\{t_0, t_1\}$. Then,

$$\begin{aligned} \frac{t_0}{2} \|\rho_0 - \rho_1\|_1 &= \frac{1}{2} \|t_0\rho_0 - t_1\rho_1 + (t_1 - t_0)\rho_1\|_1 \\ &\leq \frac{1}{2} \|t_0\rho_0 - t_1\rho_1\|_1 + \frac{1}{2} \cdot |t_0 - t_1| \end{aligned} \quad (53)$$

which, with the previous inequality, yields that $\frac{t_0}{2} \|\rho_0 - \rho_1\|_1 \leq \|t_0\rho_0 - t_1\rho_1\|_1$. Dividing both sides by two then yields the desired result. \square

In the context of tamper-evident encryption, this means that if $\frac{1}{2} \|\rho_{k,m} - \rho_{k,m'}\|_1$ is small, then either the eavesdropping attempt will be detected with high probability (in the case that the traces of both $\rho_{k,m}$ and $\rho_{k,m'}$ are small), or it will yield very little information on the plaintext if it is undetected (in the case where the trace distance between the renormalized states $\tilde{\rho}_{k,m} = \text{Tr}(\rho_{k,m})^{-1} \rho_{k,m}$ and $\tilde{\rho}_{k,m'} = \text{Tr}(\rho_{k,m'})^{-1} \rho_{k,m'}$, assuming for simplicity here that neither has trace 0). Indeed, in this second case, the adversary will not be able to distinguish between the scenario where the message m is sent or the one where the message m' is sent, *even if they later learn the key k which was used*.

¹⁶This point was also made, but not quantified as we did here, by Gottesman [[Got03](#)].

Definition 17 has two notable differences with the definition of tamper evidence originally given by Gottesman. First, we do not require the AQECM scheme to satisfy any type of encryption security guarantee to be a tamper-evident scheme. We consider tamper evidence and encryption completely separately for the time being, but we will show later in **Theorem 30** that any sufficiently good tamper-evident scheme will indeed be an encryption scheme. Second, Gottesman does not make an explicit statement on the probability of the trace distance being small. Instead, it is required that the trace distance considered in **Equation 51** be at most δ for at least $(1 - \delta) \cdot |\mathcal{K}|$ keys in \mathcal{K} . Of course, these notions coincide if the keys are sampled uniformly at random by the key generation procedure, but our formulation of this definition is a bit more general.

Before proceeding further, we make explicit two simple but useful facts which immediately follow from **Definition 17**.

Fact 19. A δ -tamper-evident AQECM scheme is also δ' -tamper evident if $\delta' > \delta$.

Fact 20. Every AQECM scheme is 1-tamper-evident, none is δ -tamper-evident if $\delta < 0$.

The definition of the security notion of tamper evidence is a bit unorthodox because it is not expressed as an expectation over the choice of the key. The following lemma expresses sufficient and necessary conditions for an AQECM scheme to be δ -tamper-evident as bounds concerning the expected trace distance

Lemma 21. Let $S = (K, E, D)$ be an AQECM as given in **Definition 13**.

1. If for all tamper attacks $A : \mathcal{L}(\mathcal{C}) \rightarrow \mathcal{L}(\mathcal{C} \otimes \mathbf{A})$ and all messages $m, m' \in \mathcal{M}$ we have that

$$\mathbb{E}_{k \leftarrow K(\varepsilon)} \frac{1}{2} \left\| ((\text{Tr}_M \circ \overline{D}_k) \circ \text{Id}_A) \circ A \circ E_k(m - m') \right\|_1 \leq \delta \quad (54)$$

then S is $\sqrt{\delta}$ -tamper-evident.

2. If S is δ -tamper-evident, then for all tamper attacks $A : \mathcal{L}(\mathcal{C}) \rightarrow \mathcal{L}(\mathcal{C} \otimes \mathbf{A})$ and all messages $m, m' \in \mathcal{M}$ we have that

$$\mathbb{E}_{k \leftarrow K(\varepsilon)} \frac{1}{2} \left\| ((\text{Tr}_M \circ \overline{D}_k) \circ \text{Id}_A) \circ A \circ E_k(m - m') \right\|_1 \leq 2\delta - \delta^2 \leq 2\delta. \quad (55)$$

Proof. We begin by showing the first point. By Markov's inequality (**Theorem 1**) and our assumed upper bound on the expectation we have

$$\left(1 - \Pr_{k \leftarrow K(\varepsilon)} \left[\frac{1}{2} \left\| ((\text{Tr}_M \circ \overline{D}_k) \circ \text{Id}_A) \circ A \circ E_k(m - m') \right\|_1 < \sqrt{\delta} \right] \right) \leq \frac{\delta}{\sqrt{\delta}} = \sqrt{\delta} \quad (56)$$

which implies that

$$\Pr_{k \leftarrow K(\varepsilon)} \left[\frac{1}{2} \left\| ((\text{Tr}_M \circ \overline{D}_k) \circ \text{Id}_A) \circ A \circ E_k(m - m') \right\|_1 < \sqrt{\delta} \right] \geq 1 - \sqrt{\delta} \quad (57)$$

and so S is $\sqrt{\delta}$ -tamper-evident.

We now show the second point. Note that if $\delta \geq \frac{1}{2}$, then the desired inequality on the expectation immediately holds as the trace distance between two subnormalized states can never be more than 1. If $\delta < \frac{1}{2}$, then it suffices to invoke the concentration inequality of [Lemma 2](#), with an upper bound of $\beta = 1$. This yields, after a few algebraic manipulations and recalling our assumption that S is δ -tamper-evident, that

$$\mathbb{E}_{k \leftarrow K(\varepsilon)} \frac{1}{2} \left\| \left((\text{Tr}_M \circ \overline{D}_k) \circ \text{Id}_A \right) \circ A \circ E_k(m - m') \right\|_1 \leq \delta + (1 - \delta) \cdot \delta = 2\delta - \delta^2 \leq 2\delta \quad (58)$$

which is the desired result. \square

We conclude this section by reiterating what is, morally, Gottesman's main theorem, namely that the theory of tamper-evident schemes is not vacuous. Tamper-evident schemes can be explicitly constructed. Better yet, for any message set \mathcal{M} and $\delta > 0$, there exists a perfectly correct AQECM scheme which is δ -tamper-evident.

Theorem 22 ([\[Got03\]](#)). Let \mathcal{M} be an alphabet and $\delta \in \mathbb{R}^+$ be a strictly positive real. There exists a perfectly correct δ -tamper-evident AQECM scheme with messages \mathcal{M} .

Gottesman explicitly demonstrates this for cases where $\mathcal{M} = \{0, 1\}^n$ for any $n \in \mathbb{N}^+$ by constructing such schemes. This result can be extended to arbitrary alphabets \mathcal{M}' by adding an injective map $i : \mathcal{M} \rightarrow \{0, 1\}^{\lceil \log_2 |\mathcal{M}'| \rceil}$ and any map $j : \{0, 1\}^{\lceil \log_2 |\mathcal{M}'| \rceil} \rightarrow \mathcal{M}'$ such that $j \circ i$ is the identity on \mathcal{M} . Messages $m \in \mathcal{M}$ are then pre-processed with i before being encoded and post-processed by j after being decoded. It is trivial to see that this preserves correctness and tamper evidence.

4 Tamper Evidence Implies Encryption

In this section, we show that any sufficiently good tamper-evident scheme is a good encryption scheme. This answers, in the positive, one of Gottesman's open question [\[Got03\]](#).

We begin by giving a simple definition of encryption for QECCMs and AQECMs, which states that the ciphertexts corresponding to two different messages m_0 and m_1 should be close in trace distance when averaging over all possible keys. Our definition is essentially the same as the one given by Ambainis, Mosca, Tapp, and de Wolf [\[AMTdW00\]](#), restricted to only considering the computational basis states and with a relaxation allowing the resulting ciphertexts to differ slightly in trace distance. This is captured in the following definition.

Definition 23. Let $\delta \in \mathbb{R}$. A QECCM or AQECM scheme (K, E, D) is δ -encrypting if, for all messages $m_0, m_1 \in \mathcal{M}$, we have that

$$\frac{1}{2} \left\| \mathbb{E}_{k \leftarrow K(\varepsilon)} E_k(m_0 - m_1) \right\|_1 \leq \delta. \quad (59)$$

Note that linearity yields $\mathbb{E}_{k \leftarrow K(\varepsilon)} E_k(m_0 - m_1) = \mathbb{E}_{k \leftarrow K(\varepsilon)} E_k(m_0) - \mathbb{E}_{k \leftarrow K(\varepsilon)} E_k(m_1)$, where the right-hand side is a bit less succinct but a bit more descriptive than what is used in [Definition 23](#).

The main theorem we prove in this section, [Theorem 30](#), is that any ϵ -correct δ -tamper-evident AQECM scheme is also $\sqrt{19(\delta + \sqrt{2}\epsilon)}$ -encrypting. As discussed in [Section 1.2.1](#), our

proof follows the same ideas as the proof given by Barnum, Crépeau, Gottesman, Smith, and Tapp showing that quantum authentication schemes are also quantum encryption schemes [BCG⁺02] and proceeds in three steps:

1. We first show in [Theorem 24](#) of [Section 4.1](#) that any AQECM scheme which does not offer much security as an encryption scheme cannot be very tamper-evident.
2. Next, we show in [Theorem 27](#) of [Section 4.2](#) that the parallel applications of a δ -tamper-evident scheme and a δ' -tamper-evident scheme yields a $(\delta + \delta')$ -tamper-evident scheme. In other words, the parallel applications of AQECM schemes yields a *linear* loss of tamper-evident security.
3. Contrasting the above point with an observation from Barnum et al. that the parallel applications of (A)QECM schemes yields an *exponential* loss of encryption security due to [Lemma 5](#), we can boost the weak bound of [Theorem 24](#). This yields our main result of this section, [Theorem 30](#) of [Section 4.3](#).

4.1 Bad Encryption Implies Bad Tamper Evidence

We show in this subsection that an AQECM scheme which is not a good encryption scheme cannot be a good tamper-evident scheme.

Theorem 24. Let $S = (K, E, D)$ be an ϵ -correct AQECM scheme. If S is *not* δ -encrypting for $\delta \geq 0$, then it is *not* $(1 - \sqrt[3]{4(1 - \delta)} - \sqrt{2\epsilon})$ -tamper-evident.

Proof. We begin by identifying pairs of values (ϵ, δ) for which the claim trivially holds. We can assume that $\delta < 1$ as there is no scheme which is not δ -encrypting for $\delta \geq 1$. We can further assume that $\epsilon \geq 0$ as there does not exist an AQECM scheme which is ϵ -correct for $\epsilon < 0$. If $1 - \sqrt[3]{4(1 - \delta)} - \sqrt{2\epsilon} < 0$, then the result trivially holds as no AQECM scheme is $\tilde{\delta}$ -tamper-evident if $\tilde{\delta} < 0$. Thus, we can further assume that $1 - \sqrt[3]{4(1 - \delta)} - \sqrt{2\epsilon} \geq 0$ for the remainder of the proof.

Next, we identify two messages and a tamper attack which we will use to demonstrate that S is not sufficiently tamper-evident. As S is not δ -encrypting by assumption, there are two messages $m_0, m_1 \in \mathcal{M}$ such that

$$\frac{1}{2} \left\| \mathbb{E}_{k \leftarrow K(\epsilon)} E_k(m_0) - \mathbb{E}_{k \leftarrow K(\epsilon)} E_k(m_1) \right\|_1 > \delta. \quad (60)$$

By [Lemma 3](#), this implies the existence of a distinguishing channel $\Phi : \mathcal{L}(\mathbb{C}) \rightarrow \mathcal{L}(\mathbb{C}^{\{0,1\}})$ satisfying

$$\langle 0 | \Phi \left(\mathbb{E}_{k \leftarrow K(\epsilon)} E_k(m_0) \right) | 0 \rangle + \langle 1 | \Phi \left(\mathbb{E}_{k \leftarrow K(\epsilon)} E_k(m_1) \right) | 1 \rangle > 1 + \delta \quad (61)$$

which, by linearity, also satisfies

$$\mathbb{E}_{k \leftarrow K(\epsilon)} (\langle 0 | \Phi(E_k(m_0)) | 0 \rangle + \langle 1 | \Phi(E_k(m_1)) | 1 \rangle) > 1 + \delta. \quad (62)$$

Let $\mathbf{A} = \mathbb{C}^{\{0,1\}}$ be the state space of a single qubit and $A = \text{CGM}(\Phi) : \mathcal{L}(\mathbb{C}) \rightarrow \mathcal{L}(\mathbb{C} \otimes \mathbf{A})$ be the coherent gentle measurement channel obtained from the distinguishing channel Φ as described in [Definition 8](#). Note that A is a tamper-attack against the scheme S and that by [Theorem 10](#) we have that

$$\frac{1}{2} \|A(\rho) - \rho \otimes |b\rangle\langle b|\|_1 \leq \sqrt{\text{Tr}(\rho) - (\langle b|\Phi(\rho)|b\rangle)^2} \quad (63)$$

for each $b \in \{0, 1\}$ and all $\rho \in \mathcal{D}_\bullet(\mathbb{C})$.

Before proceeding, we recall that tamper evidence is defined with respect to a probability over keys, and not an expectation. Thus, we use the concentration inequality of [Lemma 2](#) to translate [Equation 62](#) to this setting and obtain that

$$\begin{aligned} \Pr_{k \leftarrow K(\varepsilon)} \left[\langle 0|\Phi(E_k(m_0))|0\rangle + \langle 1|\Phi(E_k(m_1))|1\rangle > 1 + \delta' \right] &> \frac{(1 + \delta) - (1 + \delta')}{2 - (1 + \delta')} \\ &= 1 - \frac{1 - \delta}{1 - \delta'} \end{aligned} \quad (64)$$

for a yet-to-be-determined value of δ' satisfying $0 \leq \delta' + 1 < 2$, as required by [Lemma 2](#). Similarly, we use the same concentration inequality and the assumed ε -correctness of the AQECM scheme to obtain

$$\Pr_{k \leftarrow K(\varepsilon)} \left[\text{Tr}[\overline{D}_k \circ E_k(m_b)] \geq 1 - \sqrt{2\varepsilon} \right] \geq 1 - \sqrt{\frac{\varepsilon}{2}} \quad (65)$$

for each $b \in \{0, 1\}$. Note that we are only checking here that D_k accepted, not that it also obtained the correct message. Combining these previous inequalities via the union bound, we obtain that

$$\Pr_{k \leftarrow K(\varepsilon)} \left[\begin{array}{c} \langle 0|\Phi \circ E_k(m_0)|0\rangle + \langle 1|\Phi \circ E_k(m_1)|1\rangle > 1 + \delta' \\ \wedge \\ \text{Tr}[\overline{D}_k \circ E_k(m_0)] \geq 1 - \sqrt{2\varepsilon} \\ \wedge \\ \text{Tr}[\overline{D}_k \circ E_k(m_1)] \geq 1 - \sqrt{2\varepsilon} \end{array} \right] > 1 - \frac{1 - \delta}{1 - \delta'} - 2\sqrt{\frac{\varepsilon}{2}}. \quad (66)$$

Let $\mathcal{K}_{\text{Good}} \subseteq \mathcal{K}$ be the set of keys satisfying the event in the previous inequality. In other words, these are the keys which satisfy two conditions: the encodings of m_0 and m_1 under these keys are distinguished sufficiently well by Φ and, in the absence of any adversarial attack, the encodings of m_0 and m_1 under these keys will be accepted with sufficiently high probability by the decryption map. Our goal now is to show that the tamper attack A succeeds well enough when a key in $\mathcal{K}_{\text{Good}}$ is used. We note that, by definition,

$$\Pr_{k \leftarrow K(\varepsilon)} [k \in \mathcal{K}_{\text{Good}}] > 1 - \frac{1 - \delta}{1 - \delta'} - \sqrt{2\varepsilon} \quad (67)$$

and so selecting δ' in such a way that the right-hand side of this inequality is at least 0 is sufficient to ensure that $\mathcal{K}_{\text{Good}}$ is non-empty.

Now, for each $b \in \{0, 1\}$ and key $k \in \mathcal{K}_{\text{Good}}$, define the operators

$$\rho_{k,b} = ((\text{Tr}_M \circ \overline{D}_k) \otimes \text{Id}_A) \circ A \circ E_k(m_b) \quad \text{and} \quad \sigma_{k,b} = \text{Tr}[\overline{D}_k \circ E_k(m_b)] \cdot |b\rangle\langle b|. \quad (68)$$

All of these operators are subnormalized density operators on a single qubit, i.e. elements of $\mathcal{D}_\bullet(\mathbb{C}^{\{0,1\}})$, and so represent a possible state for the system held by an eavesdropping adversary who used the tamper attack A against the scheme S , scaled by the probability that this attack was undetected. The ρ operators correspond to the “real” scenario where the tamper attack A is actually applied. The σ operators, on the other hand, correspond to an “ideal” scenario where A is not actually applied, but where the adversary is simply given directly the bit corresponding to the message which was encoded.

We pause a moment to emphasize that if we can show that for every $k \in \mathcal{K}_{\text{Good}}$ we have that

$$\frac{1}{2} \|\rho_{k,0} - \rho_{k,1}\| > 1 - \frac{1 - \delta}{1 - \delta'} - \sqrt{2\epsilon} \quad (69)$$

then we will have shown that (K, E, D) is not $\left(1 - \frac{1 - \delta}{1 - \delta'} - \sqrt{2\epsilon}\right)$ -tamper-evident. This is now our goal.

For any key $k \in \mathcal{K}_{\text{Good}}$, we obtain via the triangle inequality that

$$\|\sigma_{k,0} - \sigma_{k,1}\|_1 \leq \|\sigma_{k,0} - \rho_{k,0}\|_1 + \|\rho_{k,0} - \rho_{k,1}\|_1 + \|\rho_{k,1} - \sigma_{k,1}\|_1, \quad (70)$$

which in turn implies that

$$\|\rho_{k,0} - \rho_{k,1}\|_1 \geq \|\sigma_{k,0} - \sigma_{k,1}\|_1 - \|\rho_{k,0} - \sigma_{k,0}\|_1 - \|\rho_{k,1} - \sigma_{k,1}\|_1. \quad (71)$$

Thus, a lower-bound on $\|\rho_{k,0} - \rho_{k,1}\|_1$ can be found by finding a lower bound on $\|\sigma_{k,0} - \sigma_{k,1}\|_1$ and an upper bound on $\sum_{b \in \{0,1\}} \|\rho_{k,b} - \sigma_{k,b}\|_1$.

By direct computation, we find that

$$\|\sigma_{k,0} - \sigma_{k,1}\|_1 = \text{Tr} [\overline{D}_k \circ E_k(m_0)] + \text{Tr} [\overline{D}_k \circ E_k(m_1)] \geq 2 - 2\sqrt{2\epsilon} \quad (72)$$

where the inequality follows from the assumption that $k \in \mathcal{K}_{\text{Good}}$. Next, by [Equation 63](#), we have that

$$\sum_{b \in \{0,1\}} \frac{1}{2} \|A(E_k(m_b)) - E_k(m_b) \otimes |b\rangle\langle b|\|_1 \leq \sum_{b \in \{0,1\}} \sqrt{1 - (\langle b | \Phi(E_k(m_b)) | b \rangle)^2}. \quad (73)$$

While we do not have much knowledge on the individual values of $\sqrt{1 - (\langle b | \Phi(E_k(m_b)) | b \rangle)^2}$ for each value of $b \in \{0,1\}$, we do know that $\sum_{b \in \{0,1\}} \langle b | \Phi(E_k(m_b)) | b \rangle > 1 + \delta'$ by virtue of $k \in \mathcal{K}_{\text{Good}}$. Solving the optimization problem of maximizing the right-hand side of [Equation 73](#) under this constraint, we find that

$$\begin{aligned} \sum_{b \in \{0,1\}} \frac{1}{2} \|A(E_k(m_b)) - E_k(m_b) \otimes |b\rangle\langle b|\|_1 &< 2\sqrt{1 - \left(\frac{1 + \delta'}{2}\right)^2} \\ &= \sqrt{4 - (1 + \delta')^2} \\ &< 2\sqrt{1 - \delta'} \end{aligned} \quad (74)$$

where the last inequality follows by algebraic manipulation and dropping a few terms,¹⁷ which we do to simplify later arguments. Now, as the trace distance is contractive under

¹⁷Specifically, $\sqrt{4 - (1 + \delta')^2} = \sqrt{4 - (2 + (\delta' - 1))^2} = \sqrt{4(1 - \delta') - (\delta' - 1)^2} < \sqrt{4(1 - \delta')}$.

the map $(\text{Tr}_M \circ \overline{D}_k) \otimes \text{Id}_A$ and applying this map to the states in the above trace distance will allow us to recover our ρ and σ operators, we have that

$$\sum_{b \in \{0,1\}} \frac{1}{2} \|\rho_{k,b} - \sigma_{k,b}\|_1 \leq 2\sqrt{1-\delta'}. \quad (75)$$

Combining all the above, we obtain that

$$\frac{1}{2} \|\rho_{k,0} - \rho_{k,1}\|_1 > 1 - 2\sqrt{1-\delta'} - \sqrt{2\epsilon}. \quad (76)$$

for all keys $k \in \mathcal{K}_{\text{Good}}$.

It now suffices to fix the value of δ' . We choose to take $\delta' = 1 - \left(\frac{1-\delta}{2}\right)^{2/3}$ as this implies that $2\sqrt{1-\delta'} = \frac{1-\delta}{1-\delta'} = \sqrt[3]{4(1-\delta)}$. In particular, we see that $\delta < 1$ implies that $\delta' < 1$, as required, and that $\mathcal{K}_{\text{Good}} \neq \emptyset$ as $\Pr_{k \leftarrow K(\epsilon)}[k \in \mathcal{K}_{\text{Good}}] > 1 - \sqrt[3]{4(1-\delta)} - \sqrt{2\epsilon} \geq 0$. Thus,

$$\Pr_{k \leftarrow K(\epsilon)} \left[\frac{1}{2} \|\rho_{k,0} - \rho_{k,1}\|_1 > 1 - \sqrt[3]{4(1-\delta)} - \sqrt{2\epsilon} \right] > 1 - \sqrt[3]{4(1-\delta)} - \sqrt{2\epsilon} \quad (77)$$

from which we conclude that the scheme S is not $(1 - \sqrt[3]{4(1-\delta)} - \sqrt{2\epsilon})$ -tamper-evident. \square

4.2 On The Parallel Composition of AQECM Schemes

We study here the parallel composition of AQECM schemes and how it affects the correctness and tamper evidence of such schemes.

The parallel composition of two AQECM schemes S' and S'' is a scheme $S = S' \otimes S''$ which encodes pairs of messages (m', m'') with pairs of independent keys (k', k'') to obtain pairs of ciphertexts (ρ', ρ'') . The first component of these pairs is treated with the scheme S' and the second with scheme S'' . Note that, formally, we will model these pairs as tensor products, such as $\rho' \otimes \rho''$. Ciphertexts are also decoded independently, *except* for the production of the single flag qubit necessary for a well defined AQECM. The flag qubit produced by the overall scheme S will be the result of the logical-and of the flag qubits independently produced by the component schemes S' and S'' . In other words, S accepts if and only if both of the schemes S' and S'' accept their respective ciphertexts.

This construction is formalized in [Definition 25](#). Note that Swap channels are included to ensure that keys, plaintexts, and ciphertexts are correctly ordered and distributed to the component schemes. The V channel, for its part, takes the two flag qubits produced by the component schemes and computes their logical-and.

Definition 25. Let $S' = (K', E', D')$ and $S'' = (K'', E'', D'')$ be two AQECM schemes as given in [Definition 13](#) where the notation for all associated alphabets and Hilbert spaces carry an additional prime $'$ or double prime $''$ to clarify with which scheme it is associated.

We define the parallel composition of these schemes, denoted $S' \otimes S''$, as the triplet of channels (K, E, D) defined by

$$K = K' \otimes K'' \quad (78)$$

$$E = (E' \otimes E'') \circ \text{Swap}_{(1,3,2,4)}^{(K',K'',M',M'')} \quad (79)$$

$$D = V \circ (D' \otimes D'') \circ \text{Swap}_{(1,3,2,4)}^{(K',K'',C',C'')} \quad (80)$$

where V is the channel defined by

$$\rho \mapsto \sum_{b', b'' \in \{0,1\}} (I_{M'} \otimes \langle b' | \otimes I_{M''} \otimes \langle b'' |) \rho (I_{M'} \otimes |b'\rangle \otimes I_{M''} \otimes |b''\rangle) \otimes (b' \wedge b'') \quad (81)$$

where $b' \wedge b'' \in \{0,1\}$ and $b' \wedge b'' = 1 \iff b' = b'' = 1$. The channel V can be understood as measuring and discarding the flag qubits produced by D' and D'' in the computational basis and outputting a new flag qubit whose state is the logical-and of these measurement outcomes.

Note that this yields an AQECM whose keys are the elements of $\mathcal{K} = \mathcal{K}' \times \mathcal{K}''$ and whose messages are the elements of $\mathcal{M} = \mathcal{M}' \times \mathcal{M}''$. Further note that, for any key $(k', k'') \in \mathcal{K}' \times \mathcal{K}''$, we have that

$$E_{(k', k'')} = E'_{k'} \otimes E''_{k''}, \quad D_{(k', k'')} = V \circ (D'_{k'} \otimes D''_{k''}), \quad \text{and} \quad \overline{D}_{(k', k'')} = \overline{D}'_{k'} \otimes \overline{D}''_{k''}. \quad (82)$$

We first show how correctness is preseved under this construction.

Theorem 26. Let S' and S'' be two AQECM schemes, as given in [Definition 25](#), which are ϵ' - and ϵ'' -correct, respectively. Then, $S = S' \otimes S''$ is $(\epsilon' + \epsilon'')$ -correct.

Proof. Let $m = (m', m'') \in \mathcal{M}' \times \mathcal{M}''$ be a message for S . We have that

$$\mathbb{E}_{k \leftarrow K(\epsilon)} \langle m | \overline{D}_k \circ E_k(m) | m \rangle \quad (83)$$

$$= \mathbb{E}_{\substack{k' \leftarrow K'(\epsilon) \\ k'' \leftarrow K''(\epsilon)}} \langle m', m'' | \overline{D}'_{k'} \circ E'_{k'}(m') \otimes \overline{D}''_{k''} \circ E''_{k''}(m'') | m', m'' \rangle \quad (84)$$

$$= \mathbb{E}_{k' \leftarrow K'(\epsilon)} \langle m' | \overline{D}'_{k'} \circ E'_{k'}(m') | m' \rangle \mathbb{E}_{k'' \leftarrow K''(\epsilon)} \langle m'' | \overline{D}''_{k''} \circ E''_{k''}(m'') | m'' \rangle \quad (85)$$

$$\geq (1 - \epsilon') \cdot (1 - \epsilon'') \quad (86)$$

$$\geq 1 - (\epsilon' + \epsilon'') \quad (87)$$

which is the desired result. \square

We now show how tamper evidence is preserved under parallel composition.

Theorem 27. Let S' and S'' be two AQECM schemes, as given in [Definition 25](#), which are δ' - and δ'' -tamper-evident, respectively. Then, $S = S' \otimes S''$ is $(\delta' + \delta'')$ -tamper-evident.

Proof. Fix a tamper attack $A : \mathcal{L}(\mathbb{C}) \rightarrow \mathcal{L}(\mathbb{C} \otimes \mathbb{A})$ against the scheme S . Now, for any key $k = (k', k'') \in \mathcal{K}' \times \mathcal{K}''$ and any message $m = (m', m'') \in \mathcal{M}' \times \mathcal{M}''$, let $\rho_{k,m} \in \mathcal{D}_\bullet(\mathbb{A})$ be the subnormalized state defined by

$$\rho_{k,m} = (\text{Tr}_M \otimes \text{Id}_A) \circ (\overline{D}_k \otimes \text{Id}_A) \circ A \circ E_k(m). \quad (88)$$

For the remainder of the proof, fix two messages $m_0 = (m'_0, m''_0)$ and $m_1 = (m'_1, m''_1)$ in \mathcal{M} . It suffices to show that

$$\Pr_{k \leftarrow K(\epsilon)} \left[\frac{1}{2} \|\rho_{k,m_0} - \rho_{k,m_1}\|_1 \leq \delta_0 + \delta_1 \right] \geq 1 - (\delta_0 + \delta_1). \quad (89)$$

By the triangle inequality, we have for any key $k \in \mathcal{K}$ that

$$\frac{1}{2} \left\| \rho_{k,(m'_0, m''_0)} - \rho_{k,(m'_1, m''_1)} \right\|_1 \leq \underbrace{\frac{1}{2} \left\| \rho_{k,(m'_0, m''_0)} - \rho_{k,(m'_1, m''_0)} \right\|_1}_{=N'_k} + \underbrace{\frac{1}{2} \left\| \rho_{k,(m'_1, m''_0)} - \rho_{k,(m'_1, m''_1)} \right\|_1}_{=N''_k} \quad (90)$$

where we note the presence of the subnormalized state $\rho_{k,(m'_1, m''_0)}$, corresponding to the “hybrid” message (m'_1, m''_0) , in both norms in the right-hand side of the above. It now suffices to show that N'_k is at most δ' with probability at least $1 - \delta'$ over the sampling of k and that N''_k is at most δ'' with probability at least $1 - \delta''$, over the sampling of k . Indeed, by the union bound, this would then imply that the probability over the sampling of the key k that both $N'_k \leq \delta'$ and $N''_k \leq \delta''$ is at least $1 - (\delta' + \delta'')$, which yields the desired result.

We show that $\Pr_{k \leftarrow K(\varepsilon)} [N'_k \leq \delta'] \geq 1 - \delta'$ by constructing a certain family of tamper attacks $\{A'_{k''}\}_{k'' \in \mathcal{K}''}$ against the scheme S' . The corresponding inequality for N''_k can be obtained completely analogously and will not be explicitly proven here.

For all keys $k'' \in \mathcal{K}''$ we define the tamper attack $A'_{k''} : \mathcal{L}(C') \rightarrow \mathcal{L}(C' \otimes A')$ against the scheme S' , where $A' = \mathbb{C}^{\{0,1\}} \otimes A$, by

$$\rho \mapsto ((\text{Id}_{C'} \otimes (\text{Tr}_{M''} \otimes \text{Id}_{\mathbb{C}^{\{0,1\}}}) \circ D''_{k''})) \circ A \circ (\rho \otimes E_{k''}^1(m''_0)). \quad (91)$$

In other words, $A'_{k''}$ attacks S' by first generating the state $E_{k''}''(m''_0)$, where k'' parametrizes the attack and m''_0 is determined by the fixed message m_0 we are considering in this proof, and then running the attack A against the ciphertext obtained by combining this state with the one intercepted from the honest users. The attack $A'_{k''}$ then applies the decoding channel $D''_{k''}$ on the C'' portion of the ciphertext outputted by A , discards the corresponding message register, but *keeps* the flag qubit. For all keys $k' \in \mathcal{K}'$ and messages $m' \in \mathcal{M}'$, let $\sigma_{(k', k''), m'} \in \mathcal{D}_\bullet(A')$ be the subnormalized state defined by

$$\sigma_{(k', k''), m'} = (\text{Tr}_{M'} \otimes \text{Id}_{A'}) \circ \overline{D'}_{k'} \circ A'_{k''} \circ E'_{k'}(m'). \quad (92)$$

Since S' is δ' -tamper-evident, we have that

$$\Pr_{k' \leftarrow K'(\varepsilon)} \left[\frac{1}{2} \left\| \sigma_{(k', k''), m'_0} - \sigma_{(k', k''), m'_1} \right\|_1 \leq \delta' \right] \geq 1 - \delta' \quad (93)$$

for all $k'' \in \mathcal{K}''$. Indeed, the various keys k'' simply represents different tamper attacks against the scheme S' and, by our assumption on the tamper-evident security of this scheme, the above inequality must hold for *all* attacks. Since sampling (k', k'') from $K(\varepsilon)$ is equivalent to sampling k' from $K'(\varepsilon)$ and k'' from $K''(\varepsilon)$ independently, the above implies that

$$\Pr_{(k', k'') \leftarrow K(\varepsilon)} \left[\frac{1}{2} \left\| \sigma_{(k', k''), m'_0} - \sigma_{(k', k''), m'_1} \right\|_1 \leq \delta' \right] \geq 1 - \delta'. \quad (94)$$

To complete the proof, it now suffices to show that

$$\frac{1}{2} \left\| \rho_{(k', k''), (m'_0, m''_0)} - \rho_{(k', k''), (m'_1, m''_0)} \right\|_1 \leq \frac{1}{2} \left\| \sigma_{(k', k''), m'_0} - \sigma_{(k', k''), m'_1} \right\|_1 \quad (95)$$

for all keys $(k', k'') \in \mathcal{K}$.

Recall that $\overline{D''_{k''}}$ is defined by $\rho \mapsto (I_{M''} \otimes \langle 1 |_{F''}) D''_{k''}(\rho) (I_{M''} \otimes |1\rangle_{F''})$. Moreover, note that the only difference between the subnormalized states $\rho_{(k', k''), (m', m'_0)}$ and $\sigma_{(k', k''), m'}$ is that the latter is obtained by applying $(\text{Tr}_{M''} \otimes \text{Id}_{\mathbb{C}\{0,1\}}) \circ D''_{k''}$ to the C'' register produced by the channel A and the former obtained by applying $\text{Tr}_{M''} \circ \overline{D''_{k''}}$ to this same register. Thus, for any message $m' \in \mathcal{M}''$ and any key $(k', k'') \in \mathcal{K}$, we have that

$$\rho_{(k', k''), (m', m'_0)} = (\langle 1 | \otimes I_A) \sigma_{(k', k''), m'} (|1\rangle \otimes I_A) \quad (96)$$

from which it follows, using a well-known property of the operator norm $\|\cdot\|_\infty$ (e.g. [Wat18, Eq. 1.175]), that

$$\begin{aligned} & \frac{1}{2} \left\| \rho_{(k', k''), (m'_0, m'_0)} - \rho_{(k', k''), (m'_1, m'_0)} \right\|_1 \\ & \leq \frac{1}{2} \left\| (\langle 1 | \otimes I_A) \left(\sigma_{(k', k''), m'_0} - \sigma_{(k', k''), m'_1} \right) (|1\rangle \otimes I_A) \right\|_1 \\ & \leq \frac{1}{2} \left\| (\langle 1 | \otimes I_A) \right\|_\infty \cdot \left\| \left(\sigma_{(k', k''), m'_0} - \sigma_{(k', k''), m'_1} \right) \right\|_1 \cdot \| |1\rangle \otimes I_A \|_\infty \\ & = \frac{1}{2} \left\| \left(\sigma_{(k', k''), m'_0} - \sigma_{(k', k''), m'_1} \right) \right\|_1, \end{aligned} \quad (97)$$

since $\| \langle 1 | \otimes I_A \|_\infty = \| |1\rangle \otimes I_A \|_\infty = 1$. \square

Before proceeding, we note that the repeated parallel composition of an AQECM scheme with itself is easily defined.

Definition 28. Let S be an AQECM scheme. For all $n \in \mathbb{N}^+$, we define the n -fold parallel repetition of S , denoted by $S^{\otimes n}$, by

$$S^{\otimes n} = \begin{cases} S & \text{if } n = 1 \\ S^{\otimes(n-1)} \otimes S & \text{if } n > 1. \end{cases} \quad (98)$$

Finally, the results on how correctness and tamper-evident security is preserved under parallel composition generalizes as expected to the repeated parallel composition of AQECM schemes with themselves.

Lemma 29. Let S be an AQECM scheme which is ϵ -correct and δ -tamper-evident. Then, for all $n \in \mathbb{N}^+$, the scheme $S^{\otimes n}$ is $(n\epsilon)$ -correct and $(n\delta)$ -tamper-evident.

Proof. This follows directly from the previous two results by induction. \square

4.3 Good Tamper Evidence Implies Good Encryption

We can now prove the main result of this section, namely that good tamper-evident schemes are good encryption schemes.

Theorem 30. An ϵ -correct δ -tamper-evident AQECM scheme is $\sqrt{19(\delta + \sqrt{2\epsilon})}$ -encrypting.

Proof. First, we can assume for this proof that $\delta + \sqrt{2\epsilon} < \frac{1}{19}$ as, otherwise, the result already holds since every AQECM scheme is 1-encrypting.

Let $S = (K, E, D)$ be an ϵ -correct δ -tamper-evident AQECM scheme and consider the scheme $S^{\otimes n} = (K', E', D')$, the n -fold parallel repetition of S with itself for some value $n \in \mathbb{N}^+$ to be determined later. Note that, by [Lemma 29](#), $S^{\otimes n}$ is $n\epsilon$ -correct.

Assume that S is not α -encrypting for some $\alpha \geq 0$. Then, there exists two messages $m_0, m_1 \in \mathcal{M}$ such that

$$\frac{1}{2} \left\| \mathbb{E}_{k \leftarrow K(\epsilon)} E_k(m_0) - \mathbb{E}_{k \leftarrow K(\epsilon)} E_k(m_1) \right\|_1 > \alpha. \quad (99)$$

Now, let $m'_0 = m_0^{\times n} = (m_0, \dots, m_0)$ and $m'_1 = m_1^{\times n} = (m_1, \dots, m_1)$ be the n -fold repetitions of m_0 and m_1 . Note that for each $b \in \{0, 1\}$ we have that

$$\mathbb{E}_{k' \leftarrow K'(\epsilon)} E'_{k'}(m'_b) = \left(\mathbb{E}_{k \leftarrow K(\epsilon)} E_k(m_b) \right)^{\otimes n}. \quad (100)$$

Then, [Lemma 5](#) concerning the trace distance between copies of two states yields that

$$\begin{aligned} \frac{1}{2} \left\| \mathbb{E}_{k' \leftarrow K'(\epsilon)} E'_{k'}(m'_0 - m'_1) \right\|_1 &> 1 - 2 \exp \left(-\frac{n}{2} \left(\frac{1}{2} \left\| \mathbb{E}_{k \leftarrow K(\epsilon)} E_k(m_0 - m_1) \right\|_1 \right)^2 \right) \\ &> 1 - 2 \exp \left(-\frac{n \cdot \alpha^2}{2} \right) \end{aligned} \quad (101)$$

which is to say that $S^{\otimes n}$ is not $\left(1 - 2 \exp \left(-\frac{n \cdot \alpha^2}{2} \right)\right)$ -encrypting. It follows, by [Theorem 24](#), that $S^{\otimes n}$ is not $\left(1 - 2 \exp \left(-\frac{n \cdot \alpha^2}{6} \right) - \sqrt{2n\epsilon}\right)$ -tamper-evident. However, by [Lemma 29](#), $S^{\otimes n}$ is $n\delta$ -tamper-evident. Thus, we must have that

$$1 - 2 \exp \left(-\frac{n\alpha^2}{6} \right) - \sqrt{2n\epsilon} < n\delta \quad (102)$$

which implies that

$$\exp \left(-\frac{n\alpha^2}{6} \right) > \frac{1 - n\delta - \sqrt{2n\epsilon}}{2} > \frac{1 - n(\delta + \sqrt{2\epsilon})}{2} \quad (103)$$

where the second inequality follows from the fact that $\sqrt{2n\epsilon} < n\sqrt{2\epsilon}$. We now fix the value of n to be $n = \left\lfloor \frac{1}{2(\delta + \sqrt{2\epsilon})} \right\rfloor$. Note that this quantity well defined as at least one of δ or ϵ must be larger than 0 ¹⁸ Furthermore, our assumption that $\delta + \sqrt{2\epsilon} < \frac{1}{19}$ implies that $n \geq 1$, as required for our construction of $S^{\otimes n}$. Thus, by placing this value for n in the right-hand side of the above inequality, we find that $\exp \left(-\frac{n\alpha^2}{6} \right) > \frac{1}{4}$ which then implies that

$$\alpha^2 < \frac{6 \ln(4)}{n} < \frac{6 \ln(4)}{\frac{1}{2(\delta + \sqrt{2\epsilon})} - 1} = \frac{12 \ln(4)(\delta + 2\sqrt{2\epsilon})}{1 - 2(\delta + \sqrt{2\epsilon})} < \frac{12 \ln(4)(\delta + \sqrt{2\epsilon})}{\frac{17}{19}} < 19(\delta + \sqrt{2\epsilon}) \quad (104)$$

¹⁸A perfectly correct AQECM scheme cannot be 0-tamper-evident since an adversary can always correctly guess which key was used with probability $1/|\mathcal{K}| > 0$. Against a perfectly correct scheme, an adversary who correctly guessed the key can use it to recover the plaintext undetected with certainty.

where the second inequality above follows from the fact that $n > \frac{1}{2(\delta + \sqrt{2\epsilon})} - 1$, the second to last from the assumption that $\delta + \sqrt{2\epsilon} < \frac{1}{19}$, and the last from direct computation. Taking the square root, we obtain that $\alpha < \sqrt{19(\delta + \sqrt{2\epsilon})}$.

We have thus show that if S is not α -encrypting, then $\alpha < \sqrt{19(\delta + \sqrt{2\epsilon})}$. By contraposition, if $\alpha \geq \sqrt{19(\delta + \sqrt{2\epsilon})}$, then S must be α -encrypting. In particular we have that S is $\sqrt{19(\delta + \sqrt{2\epsilon})}$ -encrypting. \square

5 Quantum Money From Any Tamper-Evident Scheme

As discussed in [Section 1.2.2](#), quantum money was first conceived by Wiesner in the founding paper of quantum cryptography [[Wie83](#)]. By leveraging the no-cloning principle, a bank is able to mint unforgeable banknotes by incorporating into them quantum systems whose specific states are unknown to the general public. In 2011, Gottesman sketched how to obtain a secure quantum money scheme from any secure tamper-evident scheme [[Got11](#)].

In this section, we formalize Gottesman’s construction of a quantum money scheme from any tamper-evident scheme and we quantify and prove the level of security it achieves. We do this in [Section 5.2](#) after reviewing the relevant definitions pertaining to quantum money in [Section 5.1](#).

5.1 Defining Quantum Money

Formally, we define a quantum money scheme as a triplet of channels: a *key generation* channel K , a *minting* channel M , and a *verification* channel V . To produce a banknote, the bank first samples a classical secret key k via the key generation channel, $k \leftarrow K(\epsilon)$, and then uses it with the minting channel M to produce a quantum state: $\rho_k = M(k)$. The resulting quantum state ρ_k is the banknote. We then suppose that the bank places this banknote in circulation, but that it eventually receives it back as part of a deposit. The bank can then, with the help of the key k , attempt to validate the banknote via the verification channel V . This channel either accepts by outputting 1 or rejects by outputting 0. This is captured later in [Definition 31](#). We say that a quantum money scheme is secure if it is infeasible for an adversary having access to a *single* honestly produced banknote to output *two* quantum systems which would both be accepted by the bank’s verification procedure. This is formalized in [Definition 33](#).

Note that what we have described here is a *symmetric-* or *private-key* quantum money scheme: the key k used to generate the banknote ρ_k is the same as the one used to later validate it. This is in contrast to *public-key* quantum money schemes which have also been discussed in the literature (e.g.: [[AC12](#)]). These schemes admit a publicly known verification key which allows anyone — not only the bank — to verify if a supposed banknote is legitimate or not, but which does not aid adversaries in producing forgeries. Public-key quantum money schemes are typically studied in the context of computational assumptions and we do not consider them in this work.

The syntax we have outlined here and which we formalize in the next definition is implicit in Wiesner’s original work on quantum money [[Wie83](#)]. It is also essentially the

one given in Aaronson and Christiano’s more modern work on this topic [AC12], up to two changes. First, we identify the public and private keys in Aaronson and Christiano’s work to be a single private key. Second, we move their definition from a computational setting, i.e. considering polynomial-time algorithms, to an information-theoretic setting, i.e. considering arbitrary quantum channels. We also note that our definition abstracts away the problem of determining which key is associated to which banknote. The standard solution, without introducing any computational assumptions, is for the banknote to be actually composed of a pair (ρ_k, s) where s is a classical serial number. This serial number is selected at random and the bank to maintain a large database mapping serial numbers to the private keys used to generate and verify the banknotes. We will not consider the issue of properly associating keys to banknotes any further.

Definition 31. A *quantum money scheme* is a triplet of channels (K, M, V) of the form

$$K : \mathbb{C} \rightarrow \mathcal{L}(\mathbf{K}), \quad M : \mathcal{L}(\mathbf{K}) \rightarrow \mathcal{L}(\mathbf{N}), \quad \text{and} \quad V : \mathcal{L}(\mathbf{K} \otimes \mathbf{N}) \rightarrow \mathcal{L}(\mathbf{F}) \quad (105)$$

for an alphabet \mathcal{K} and Hilbert spaces $\mathbf{K} = \mathbb{C}^{\mathcal{K}}$, \mathbf{N} , and $\mathbf{F} = \mathbb{C}^{\{0,1\}}$. The elements of \mathcal{K} are called the *keys* of the scheme. Moreover, for every key $k \in \mathcal{K}$ we additionally define the channel $V_k : \mathcal{L}(\mathbf{N}) \rightarrow \mathcal{L}(\mathbf{F})$ by $\rho \mapsto V(k \otimes \rho)$ and the map $\bar{V}_k : \mathcal{L}(\mathbf{N}) \rightarrow \mathbb{C}$ by $\rho \mapsto \langle 1 | V_k(\rho) | 1 \rangle$.

A quantum money scheme is said to be ϵ -correct if *every* banknote which it can generate, which is to say those produced by any key with a non-zero chance of being sampled, will be accepted with probability at least $1 - \epsilon$. This is analogous to the definition given by Aaronson and Christiano [AC12].

Definition 32. Let $\epsilon \in \mathbb{R}$. A quantum money scheme (K, M, V) as given in Definition 31 is ϵ -correct if for all keys $k \in \mathcal{K}$ we have that

$$\langle k | K(\epsilon) | k \rangle > 0 \implies \bar{V}_k \circ M(k) \geq 1 - \epsilon. \quad (106)$$

We now define our security notion. This notion quantifies an upper bound on the ability of any adversary to transform one honest banknote into two forgeries which would both be accepted, with the same key, by the bank. This notion is implicit in Wiesner’s original work [Wie83] and is the one with respect to which Molina, Vidick, and Watrous prove the security of Wiesner’s scheme [MVW13]. In particular, the adversarial counterfeiter is not able to query the bank’s verification procedure during the course of their attack. These are called *simple counterfeiting attacks*¹⁹ and they are the only ones we consider in this work.

Definition 33. Let $\delta \in \mathbb{R}$. A quantum money scheme (K, M, V) as given in Definition 31 is δ -secure if for all channels $A : \mathcal{L}(\mathbf{N}) \rightarrow \mathcal{L}(\mathbf{N} \otimes \mathbf{N})$ we have that

$$\mathbb{E}_{k \leftarrow K(\epsilon)} (\bar{V}_k \otimes \bar{V}_k) \circ A \circ M(k) \leq \delta. \quad (107)$$

¹⁹For discussions on more involved attack models against quantum money schemes, we invite the interested reader to examine the works of Lutowski [Lut10] and of Nagaï, Sattah, Brodutch, and Unruh [NSBU16].

5.2 Gottesman’s Construction of Quantum Money

Now that we have the necessary definitions pertaining to quantum money, we can formalize Gottesman’s construction of such a scheme from any tamper-evident scheme [Got11]. We do so in Definition 34, after which we state the correctness and security of the resulting scheme in Theorem 35 and Theorem 39 after proving a few lemmas.

As discussed in Section 1.2.2, the basic idea of Gottesman’s construction is to start with a tamper-evident scheme (K, E, D) and to obtain banknotes by encoding a randomly chosen message with a randomly chosen key. The bank, which knows the key-message pair, can verify a candidate banknote by decoding it according to the tamper-evident scheme and verifying that the state was accepted *and* that the correct message was obtained. In this construction, the keys of the resulting quantum money scheme are pairs composed of a key and a message from the underlying tamper-evident scheme.

A non-trivial issue which was not discussed by Gottesman but which must be considered in a formal construction occurs when the underlying tamper-evident scheme is not perfectly correct. If a tamper-evident scheme (K, E, D) is not perfectly correct, then there may exist key-message pairs (k, m) such that the decryption map D_k only accepts and correct decoded $E_k(m)$ with arbitrarily small, perhaps even 0, probability. This follows from the definition of correctness for AQECM schemes (Definition 14) which only requires each message to be accepted and correctly recovered with sufficient high probability *over the expected choice of the key*. However, correctness of a quantum money scheme (Definition 32) requires that banknotes produced with *any valid key* be accepted with high probability. Thus, naively instantiating Gottesman’s construction with an AQECM scheme which is not perfectly correct may yield a quantum money scheme without a significant level of correctness.

To solve this issue, we require that the key generation map of the resulting quantum money scheme only samples from key-message pairs (k, m) with a sufficiently high probability that $E_k(m)$ will be correctly decoded and accepted by D_k . More precisely, we parametrize our construction by a real value $\gamma \in \mathbb{R}$ and only sample key-message pairs (k, m) for which it holds that $\langle m | \overline{D}_k \circ E_k(m) | m \rangle \geq 1 - \gamma$. Our construction must also account for the possibility that the value of γ is such that no key-message pair (k, m) satisfies this condition. In this case, we fall back to an essentially trivial scheme which will be correct, but offer no security. All of this is captured in Definition 34. Recall that our construction is in the information-theoretic setting and so we need not worry about the possible complexity of identifying and sampling from this subset of key-message pairs. We discuss this point in more detail at the end of this section.

Definition 34. Let $S = (K, E, D)$ be an AQECM scheme as given in Definition 13, let $\gamma \in \mathbb{R}$ be a real number, and let $\mathcal{G} \subseteq \mathcal{K} \times \mathcal{M}$ be the set of key-message pairs for S satisfying

$$\langle k | K(\varepsilon) | k \rangle > 0 \quad \text{and} \quad \langle m | \overline{D}_k \circ E_k(m) | m \rangle \geq 1 - \gamma. \quad (108)$$

We define the quantum money scheme $\text{QM}_\gamma(S) = (K', M', V')$ in one of two ways, depending on if \mathcal{G} is empty or not. In both cases, the keys will be elements of $\mathcal{K}' = \mathcal{K} \times \mathcal{M}$, implying that the Hilbert space of the key space of $\text{QM}_\gamma(S)$ is $\mathcal{K}' = \mathcal{K} \otimes \mathcal{M}$, and the banknotes will be states on the Hilbert space \mathbb{C} corresponding to the ciphertexts of S , implying that the state space of the banknotes is $\mathcal{N}' = \mathbb{C}$.

If \mathcal{G} is non-empty, we define $\text{QM}_\gamma(S) = (K', M', V')$ as follows:

- The key generation channel K' for the quantum money scheme $\text{QM}_\gamma(S)$ is obtained by sampling a message m uniformly a random from the message space \mathcal{M} of S and a key k according to the key generation procedure K of S , conditioned on the resulting pair (k, m) being in \mathcal{G} .

More formally, consider a key-message pair (k, m) where k is sampled according to the AQECM's key generation channel and where m is sampled uniformly at random. Let $p_{\mathcal{G}} = \sum_{(k,m) \in \mathcal{G}} \langle k | K(\varepsilon) | k \rangle \cdot \frac{1}{|\mathcal{M}|}$ be the probability that a key-message pair generated in this way is in \mathcal{G} . Note that $p_{\mathcal{G}} > 0$ as \mathcal{G} is non-empty. We then define K' by

$$c \mapsto c \cdot \frac{1}{p_{\mathcal{G}}} \sum_{(k,m) \in \mathcal{G}} \frac{\langle k | K(\varepsilon) | k \rangle}{|\mathcal{M}|} |k, m\rangle \langle k, m|. \quad (109)$$

In particular, we see that $\langle k, m | K'(\varepsilon) | k, m \rangle = \frac{\langle k | K(\varepsilon) | k \rangle}{p_{\mathcal{G}} \cdot |\mathcal{M}|}$ for any pair $(k, m) \in \mathcal{G}$.

- On input of a key-message pair (k, m) , the minting channel M' encrypts m with the key k using the encryption map E of S . In other words, $M' = E$.
- On input of a key-message pair (k, m) and a candidate banknote ρ , the verification channel V' decrypts ρ using the key k with the AQECM's decryption channel D . It then accepts if D accepts *and* produces m . Otherwise, it rejects.

Formally, and in full generality, V' is given by

$$\rho \mapsto \left(\sum_{m \in \mathcal{M}} \langle m | \bar{D}((I_{\mathbb{K}} \otimes \langle m |_{\mathbb{M}} \otimes I_{\mathbb{C}}) \rho (I_{\mathbb{K}} \otimes |m\rangle_{\mathbb{M}} \otimes I_{\mathbb{C}})) | m \rangle \right) (|1\rangle\langle 1| - |0\rangle\langle 0|) + \text{Tr}(\rho) |0\rangle\langle 0|. \quad (110)$$

This can be more easily parsed in the case that ρ is the tensor of a well formed key for the quantum money scheme and some candidate banknote: $\rho = |\tilde{k}\rangle\langle \tilde{k}| \otimes |\tilde{m}\rangle\langle \tilde{m}| \otimes \sigma$. In this case, we see that

$$\begin{aligned} V'(|\tilde{k}\rangle\langle \tilde{k}| \otimes |\tilde{m}\rangle\langle \tilde{m}| \otimes \sigma) &= \langle \tilde{m} | \bar{D}(|\tilde{k}\rangle\langle \tilde{k}| \otimes \sigma) | \tilde{m} \rangle (|1\rangle\langle 1| - |0\rangle\langle 0|) + \text{Tr}(\sigma) |0\rangle\langle 0| \\ &= \langle \tilde{m} | \bar{D}_{\tilde{k}}(\sigma) | \tilde{m} \rangle |1\rangle\langle 1| + (\text{Tr}(\sigma) - \langle \tilde{m} | \bar{D}_{\tilde{k}}(\sigma) | \tilde{m} \rangle) |0\rangle\langle 0| \\ &= p_{\text{Accept}} \cdot |1\rangle\langle 1| + (1 - p_{\text{Accept}}) \cdot |0\rangle\langle 0| \end{aligned} \quad (111)$$

where $p_{\text{Accept}} = \langle \tilde{m} | \bar{D}_{\tilde{k}}(\sigma) | \tilde{m} \rangle$ is the probability that the ciphertext is accepted and the message \tilde{m} is obtained.²⁰

If \mathcal{G} is empty, we define $\text{QM}_\gamma(S) = (K', M', V')$ as in the previous case, but with the following two differences:

- We take $K' : \mathbb{C} \rightarrow \mathcal{L}(\mathbb{K}')$ to be defined by

$$c \mapsto c \cdot K(\varepsilon) \otimes \frac{I_{\mathbb{M}}}{\dim \mathbb{M}}, \quad (112)$$

which is to say that a key-message pairs (k, m) is obtained by sampling m uniformly at random from \mathcal{M} and k according to K .

²⁰Note that the $\text{Tr}(\rho)$ term, which reduces to $\text{Tr}(\sigma) = 1$ in our example, is necessary to ensure that V' remains trace-preserving in the case that $\text{Tr}(\rho) \neq 1$.

- We take V' to be defined by $\rho \mapsto \text{Tr}(\rho) \cdot |1\rangle\langle 1|$, i.e., V' always accepts.

We define this construction even in the case where \mathcal{G} is empty so that $\text{QM}_\gamma(S)$ is well defined for any AQECM S and real value γ . In particular, the map $S \mapsto \text{QM}_\gamma(S)$ taking AQECM schemes to quantum money schemes is well defined for all values $\gamma \in \mathbb{R}$.

Note that our definition of $\text{QM}_\gamma(S)$ when \mathcal{G} is empty has no chance of offering any non-trivial security since the verification procedure always accepts. On the other hand, this yields a scheme which is perfectly correct. Thus, we obtain the following theorem concerning the correctness of $\text{QM}_\gamma(S)$ and emphasize that it is independent of the correctness of S .

Theorem 35. Let $S = (K, E, D)$ be an AQECM scheme and let $\gamma \in \mathbb{R}_0^+$ be a non-negative real. Then, the quantum money scheme $\text{QM}_\gamma(S) = (K', V', M')$ is γ -correct.

Proof. Let \mathcal{G} be defined as in [Definition 34](#). If \mathcal{G} is empty, then V' always accepts by construction and so

$$\langle 1 | V'_{k'} \circ M'(k') | 1 \rangle = 1 \geq 1 - \gamma \quad (113)$$

for any key $k' \in \mathcal{K} \otimes \mathcal{M}$. This implies that $\text{QM}_\gamma(S)$ is γ -correct.

If \mathcal{G} is not empty, then any key $k' = (k, m)$ for the quantum money scheme which satisfies $\langle k, m | K'(\varepsilon) | k, m \rangle > 0$ must be in \mathcal{G} . For such keys, we have by construction that

$$\langle 1 | V'_{k'} \circ M'(k') | 1 \rangle = \langle m | \overline{D}_k \circ E_k(m) | m \rangle \geq 1 - \gamma. \quad (114)$$

Thus, $\text{QM}_\gamma(S)$ is γ -correct. \square

We now move on to demonstrating the security of $\text{QM}_{\sqrt{\epsilon}}(S)$ if the underlying AQECM scheme $S = (K, E, D)$ is ϵ -correct and δ -tamper-evident. We begin by sketching the ideas involved in this proof, emphasizing that these were first presented by Gottesman [\[Got11\]](#).

Consider an attack A against the quantum money scheme $\text{QM}_{\sqrt{\epsilon}}(S)$. For this attack to succeed, it must, on input of a single ciphertext $E_k(m)$, produce a bipartite state on two registers such that both will be accepted and both will produce to correct message when decoded by the channel D_k . Clearly, an upper bound on the probability of this occurring is the probability that the first instance of D_k accepts, but may not have recovered the correct message, and that the second instance of D_k recovers the correct message, but may not have accepted. Our proof consists of upper-bounding this probability by leveraging the fact that S is tamper-evident. Indeed, tamper evidence means that any eavesdropping attempt — roughly corresponding to a counterfeiting attack against the resulting quantum money scheme — will either be detected (i.e. the first instance of the D_k map will reject) with high probability or will not provide much information on the encoded message (i.e. the second instance of the D_k map will not recover m with high probability).

Our goal is now to formalize this argument. There are two technical points which need to be considered to obtain a proper proof:

1. The definition of tamper evidence, [Definition 17](#), considers the ability of an adversary to distinguish, undetected, between any two specific plaintexts. To prove the security of $\text{QM}_{\sqrt{\epsilon}}(S)$, we need a statement about the (in)ability of an adversary to determine, undetected, which *specific* message was sent among many possibilities.

2. Recall that the way key-message pairs (k, m) are sampled in $\text{QM}_\gamma(S)$ may be slightly different from the way they would be sampled when evaluating the security of S as a tamper-evident scheme. This occurs, roughly, when $\mathcal{G} \neq \mathcal{K} \times \mathcal{M}$. We will need to account for this difference in our proof.

We give two lemmas to overcome these two points.

The first point is covered by [Lemma 37](#). In this lemma, we consider an adversary characterized by two parts which act sequentially. First, there is an initial tamper-attack A which, as usual, is understood as trying to obtain some information on the encoded plaintext without being detected. Second, there is a set of channels $\{A_k\}_{k \in \mathcal{K}}$ indexed by the keys of the AQECM scheme which attempt to explicitly guess the plaintext based on what the initial attack A gathered.²¹ The fact that these channels are indexed by the keys models the fact that, at this point, we will assume that the adversary knows the key. The lemma bounds the ability of this two-part adversary to remain undetected *and* correctly guess the value of the message encoded by the tamper-evident scheme after they have learned the key. To prove [Lemma 37](#), we will make use of another technical lemma, [Lemma 36](#). This second lemma gives a bound on how well any quantum channel can distinguish (subnormalized) states from a given set. In this sense, it can be thought of as a generalization of [Lemma 3](#) which considered only the case of sets given by precisely two states. Note that, unlike [Lemma 3](#), we do not claim that [Lemma 36](#) always gives an optimal bound.

The second point is covered by [Lemma 38](#), which is a statement purely of probability theory giving an upper bound on the change in the expectation of a non-negative function when going from one random variable to another which is simply the first conditioned on some particular event occurring.

We now state and prove these lemmas.

Lemma 36. Let \mathcal{M} be an alphabet and, for each $m \in \mathcal{M}$, let $\rho_m \in \mathcal{D}_\bullet(\mathbb{H})$ be a subnormalized density operator on a Hilbert space \mathbb{H} . Further, let $\delta \in \mathbb{R}$ be a real value such that for all $m_0, m_1 \in \mathcal{M}$ we have that $\frac{1}{2} \|\rho_{m_0} - \rho_{m_1}\|_1 \leq \delta$. Then, for any random variable μ distributed on \mathcal{M} and any channel $\Phi : \mathcal{L}(\mathbb{H}) \rightarrow \mathcal{L}(\mathbb{C}^{\mathcal{M}})$, we have that

$$\mathbb{E}_{m \leftarrow \mu} \langle m | \Phi(\rho_m) | m \rangle \leq \left(\max_{m \in \mathcal{M}} \Pr[\mu = m] \right) \cdot (1 - 2\delta) + 2\delta. \quad (115)$$

Proof. Let $p_m = \Pr[\mu = m]$ for all $m \in \mathcal{M}$ and let $m' \in \mathcal{M}$ be an element that satisfies $p_{m'} = \max_{m \in \mathcal{M}} \Pr[\mu = m]$. By singling out the m' contribution to the expectation and recalling that $\text{Tr}(\rho_{m'}) = \sum_{m \in \mathcal{M}} \langle m | \rho_{m'} | m \rangle$, we have that

$$\begin{aligned} \mathbb{E}_{m \leftarrow \mu} \langle m | \Phi(\rho_m) | m \rangle &= p_{m'} \langle m' | \Phi(\rho_{m'}) | m' \rangle + \sum_{m \in \mathcal{M} \setminus \{m'\}} p_m \cdot \langle m | \Phi(\rho_m) | m \rangle \\ &= p_{m'} \text{Tr}(\rho_{m'}) + \sum_{m \in \mathcal{M} \setminus \{m'\}} (p_m \langle m | \Phi(\rho_m) | m \rangle - p_{m'} \langle m' | \Phi(\rho_{m'}) | m' \rangle) \end{aligned} \quad (116)$$

²¹In the context of our proof of security for the quantum money scheme $\text{QM}_\gamma(S)$ these will be taken to be specifically $A_k = (\text{Id}_M \otimes \text{Tr}_F) \circ D_k$, which is to say the honest decryption channel which discards the flag output. However, our lemma is more general.

As $p_{m'} \geq p_m$ for all $m \in \mathcal{M}$, we can replace $p_{m'}$ by p_m in each term of the summation at the cost of introducing an inequality. At the same time, we recall that $\text{Tr}(\rho_{m'}) \leq 1$. Thus,

$$\begin{aligned} \mathbb{E}_{m \leftarrow \mu} \langle m | \Phi(\rho_m) | m \rangle &\leq p_{m'} + \sum_{\mathcal{M} \setminus \{m'\}} p_m \cdot (\langle m | \Phi(\rho_m) | m \rangle - \langle m | \Phi(\rho_{m'}) | m \rangle) \\ &\leq p_{m'} + \sum_{\mathcal{M} \setminus \{m'\}} p_m \cdot |\langle m | \Phi(\rho_m - \rho_{m'}) | m \rangle| \end{aligned} \quad (117)$$

By invoking a slight generalization of [Lemma 3](#) which we will not formally prove,²² we can give upper bounds to the absolute values in the summands in terms of the trace distance. Further recalling that the trace distance is contractive under the action of channels, we obtain

$$\begin{aligned} \mathbb{E}_{m \leftarrow \mu} \langle m | \Phi(\rho_m) | m \rangle &\leq p_{m'} + \sum_{m \in \mathcal{M} \setminus \{m'\}} p_m \cdot \|\rho_m - \rho_{m'}\|_1 \\ &\leq p_{m'} + (1 - p_{m'}) \cdot 2\delta \end{aligned} \quad (118)$$

where we invoke our assumption of the pair-wise trace distance between the subnormalized states we consider and that $\sum_{m \in \mathcal{M} \setminus \{m'\}} p_m = 1 - p_{m'}$. Rearranging the terms yields the desired result. \square

Note that if $\text{Tr}(\rho_m) = \text{Tr}(\rho_{m'})$ for all $m \in \mathcal{M}$, then we can obtain a better bound. Indeed, under this assumption [Lemma 3](#) yields $|\langle m | \Phi(\rho_m - \rho_{m'}) | m \rangle| \leq \frac{1}{2} \|\rho_m - \rho_{m'}\|_1$ instead of $|\langle m | \Phi(\rho_m - \rho_{m'}) | m \rangle| \leq \|\rho_m - \rho_{m'}\|_1$, implying a final bound of $p_{m'} + (1 - p_{m'})\delta$. Moreover, this matches the bound of [Lemma 3](#) if $\mathcal{M} = \{0, 1\}$, μ is uniformly random, and both traces are 1.

We can now state and prove [Lemma 37](#).

Lemma 37. Let (K, E, D) be a δ -tamper-evident AQECM as given in [Definition 13](#) with $\delta \leq 1$ and let μ be a random variable on the messages of this scheme. For any tamper-attack $A : \mathcal{L}(\mathbb{C}) \rightarrow \mathcal{L}(\mathbb{C} \otimes \mathbb{A})$ against this scheme and any set $\{A'_k : \mathcal{L}(\mathbb{A}) \rightarrow \mathcal{L}(\mathbb{M})\}_{k \in \mathcal{K}}$ of channels indexed by the keys of the scheme, we have that

$$\mathbb{E}_{\substack{k \leftarrow K(\varepsilon) \\ m \leftarrow \mu}} \langle m | ((\text{Tr}_{\mathbb{M}} \circ \overline{D}_k) \otimes A'_k) \circ A \circ E_k(m) | m \rangle \leq \left(\max_{m \in \mathcal{M}} \Pr[\mu = m] \right) (1 - 4\delta) + 4\delta. \quad (119)$$

Proof. For any key k and message m of the AQECM scheme (K, E, D) , define the two operators

$$\rho_{k,m} = ((\text{Tr}_{\mathbb{M}} \circ \overline{D}_k) \otimes \text{Id}_{\mathbb{A}}) \circ A \circ E_k(m) \quad \text{and} \quad \sigma_{k,m} = A'_k(\rho_{k,m}). \quad (120)$$

More precisely, $\rho_{k,m} \in \mathcal{D}_{\bullet}(\mathbb{A})$ is the (subnormalized) state held by the adversary after the verifier has verified the ciphertext but before they learn the key, and $\sigma_{k,m} \in \mathcal{D}_{\bullet}(\mathbb{M})$ can be understood as the adversaries subsequent guess of m after having been given the key k . Note that the $\rho_{k,m}$ operators are precisely those in the left-hand side of [Equation 119](#).

²²Recall that [Lemma 3](#) implies that $|\langle 0 | \Phi(\rho - \sigma) | 0 \rangle| \leq \|\rho - \sigma\|_1$ for any two subnormalized density operators $\rho, \sigma \in \mathcal{D}_{\bullet}(\mathbb{H})$ and any channel $\Phi : \mathcal{L}(\mathbb{H}) \rightarrow \mathcal{L}(\mathbb{C}^{\{0,1\}})$. The slight generalizing here is changing the codomain of Φ to $\mathcal{L}(\mathbb{C}^{\mathcal{M}})$ and arguing that the inequality does not depend on the element we pick in \mathcal{M} .

Now, by linearity and [Lemma 36](#) with $\Phi = \text{Id}_M$, it suffices for us to show that that $\frac{1}{2} \left\| \mathbb{E}_{k \leftarrow K(\varepsilon)} \sigma_{k,m} - \mathbb{E}_{k \leftarrow K(\varepsilon)} \sigma_{k,m'} \right\| \leq 2\delta$ for all $m, m' \in \mathcal{M}$ to obtain the desired result. To obtain this bound, we observe that the triangle inequality allows us to take the expectation out of the norm and the fact that the trace distance is contractive under the action of channels allows us to pass from the σ operators to the ρ operators. This yields that

$$\begin{aligned} \frac{1}{2} \left\| \mathbb{E}_{k \leftarrow K(\varepsilon)} \sigma_{k,m} - \mathbb{E}_{k \leftarrow K(\varepsilon)} \sigma_{k,m'} \right\| &\leq \mathbb{E}_{k \leftarrow K(\varepsilon)} \frac{1}{2} \left\| \sigma_{k,m} - \sigma_{k,m'} \right\| \\ &\leq \mathbb{E}_{k \leftarrow K(\varepsilon)} \frac{1}{2} \left\| \rho_{k,m} - \rho_{k,m'} \right\|. \end{aligned} \quad (121)$$

It now suffices to show that $\mathbb{E}_{k \leftarrow K(\varepsilon)} \frac{1}{2} \left\| \rho_{k,m} - \rho_{k,m'} \right\|_1 \leq 2\delta$. However, this follows directly from the fact that S is assumed to be δ -tamper-evident and [Lemma 21](#) which states that δ -tamper-evidence implies a 2δ upper-bound on this expectation. \square

We now state and prove [Lemma 38](#) which will help us overcome the second technical hurdle we had identified. As mentioned, this is a result purely of probability theory.

Lemma 38. Let \mathcal{A} be an alphabet, A be a random variable distributed on \mathcal{A} , $\mathcal{B} \subseteq \mathcal{A}$ be a subset such that $\Pr[A \in \mathcal{B}] > 0$, and $f : \mathcal{A} \rightarrow \mathbb{R}_0^+$ be any map. Finally, let B be the random variable distributed on \mathcal{B} defined by $\Pr[B = b] = \Pr[A = b] / \Pr[A \in \mathcal{B}]$, i.e. B is simply A conditioned on $A \in \mathcal{B}$. Then

$$\left| \mathbb{E}_{a \leftarrow A} f(a) - \mathbb{E}_{a \leftarrow B} f(a) \right| \leq \max_{a \in \mathcal{A}} f(a) \cdot \Pr[A \notin \mathcal{B}]. \quad (122)$$

Proof. By definition of the expectation and our random variables, we find

$$\begin{aligned} \left| \mathbb{E}_{a \leftarrow A} f(a) - \mathbb{E}_{a \leftarrow B} f(a) \right| &= \left| \sum_{a \in \mathcal{A}} \Pr[A = a] \cdot f(a) - \sum_{a \in \mathcal{B}} \frac{\Pr[A = a]}{\Pr[A \in \mathcal{B}]} \cdot f(a) \right| \\ &= \left| \sum_{a \in \mathcal{A} \setminus \mathcal{B}} \Pr[A = a] \cdot f(a) - \sum_{a \in \mathcal{B}} \left(\frac{\Pr[A = a]}{\Pr[A \in \mathcal{B}]} - \Pr[A = a] \right) \cdot f(a) \right| \\ &= \left| \sum_{a \in \mathcal{A} \setminus \mathcal{B}} \Pr[A = a] \cdot f(a) - \sum_{a \in \mathcal{B}} (1 - \Pr[A \in \mathcal{B}]) \frac{\Pr[A = a]}{\Pr[A \in \mathcal{B}]} \cdot f(a) \right|. \end{aligned} \quad (123)$$

Since the codomain of f is \mathbb{R}_0^+ , the last of these absolute values is the absolute value of the difference between two non-negative real values. Hence, the absolute value of the difference is upper-bounded by the maximum of these two values. Noting that

$$\begin{aligned} \sum_{a \in \mathcal{A} \setminus \mathcal{B}} \Pr[A = a] \cdot f(a) &\leq \sum_{a \in \mathcal{A} \setminus \mathcal{B}} \Pr[A = a] \cdot \max_{a \in \mathcal{A}} f(a) \\ &= \Pr[A \notin \mathcal{B}] \cdot \max_{a \in \mathcal{A}} f(a) \end{aligned} \quad (124)$$

and

$$\begin{aligned} \sum_{a \in \mathcal{B}} (1 - \Pr[A \in \mathcal{B}]) \frac{\Pr[A = a]}{\Pr[A \in \mathcal{B}]} \cdot f(a) &\leq \Pr[A \notin \mathcal{B}] \frac{\sum_{a \in \mathcal{B}} \Pr[A = a]}{\Pr[A \in \mathcal{B}]} \cdot \max_{a \in \mathcal{A}} f(a) \\ &= \Pr[A \notin \mathcal{B}] \cdot \max_{a \in \mathcal{A}} f(a) \end{aligned} \quad (125)$$

yields the desired result. \square

With [Lemma 37](#) and [Lemma 38](#) in hand, we can now state and prove the security of the quantum money scheme $\text{QM}_{\sqrt{\epsilon}}(S)$.

Theorem 39. Let $S = (K, E, D)$ be an ϵ -correct δ -tamper-evident AQECM scheme with messages \mathcal{M} . Then, the quantum money scheme $\text{QM}_{\sqrt{\epsilon}}(S)$ is $(|\mathcal{M}|^{-1} + 4\delta + \sqrt{\epsilon})$ -secure.

Proof. First, we assume that $\epsilon < 1$. Otherwise, the result trivially holds since any quantum money scheme is δ' -secure for any $\delta' \geq 1$.

Now, note that the set

$$\mathcal{G} = \{(k, m) \in \mathcal{K} \times \mathcal{M} : \langle k | K(\epsilon) | k \rangle > 0 \wedge \langle m | \overline{D}_k \circ E_k(m) | m \rangle \geq 1 - \sqrt{\epsilon}\} \quad (126)$$

used in the construction of $\text{QM}_{\sqrt{\epsilon}}(S)$ is non-empty. Indeed, as the AQECM scheme S is assumed to be ϵ -correct, we have that

$$\mathbb{E}_{m \leftarrow \mathcal{M}} \mathbb{E}_{k \leftarrow K(\epsilon)} \langle m | \overline{D}_k \circ E(m) | m \rangle \geq 1 - \epsilon \quad (127)$$

which, by the concentration inequality of [Lemma 2](#), implies that

$$\Pr_{\substack{k \leftarrow K(\epsilon) \\ m \leftarrow \mathcal{M}}} [(k, m) \in \mathcal{G}] = \Pr_{\substack{k \leftarrow K(\epsilon) \\ m \leftarrow \mathcal{M}}} [\langle m | \overline{D}_k \circ E(m) | m \rangle \geq 1 - \sqrt{\epsilon}] \geq 1 - \sqrt{\epsilon} > 0. \quad (128)$$

It follows that the quantum money scheme $\text{QM}_{\sqrt{\epsilon}}(S) = (K', M', V')$ is constructed according to the non-empty \mathcal{G} case of [Definition 34](#). Recalling this definition, we see that for any counterfeiting attack $A' : \mathcal{L}(\mathbb{C}) \rightarrow \mathcal{L}(\mathbb{C} \otimes \mathbb{C})$ and any $(k, m) \in \mathcal{K} \times \mathcal{M} = \mathcal{K}'$, we have that

$$\begin{aligned} (\overline{V}'_{(k,m)} \otimes \overline{V}'_{(k,m)}) \circ A' \circ M'(k \otimes m) &= \langle m, m | (\overline{D}_k \otimes \overline{D}_k) \circ A' \circ E_k(m) | m, m \rangle \\ &\leq \langle m | \left((\text{Tr}_{\mathbb{M}} \circ \overline{D}_k) \otimes \tilde{D}_k \right) \circ A' \circ E_k(m) | m \rangle \end{aligned} \quad (129)$$

where $\tilde{D}_k = (\text{Id}_{\mathbb{M}} \otimes \text{Tr}_{\mathbb{F}}) \circ D_k$ is the decoding channel which discards, without verifying, the accept/reject flag. At a high-level this inequality is obtained by noting that the probability that both instances of the map D_k accept *and* decode the correct message is no greater than the probability that the first accepts, possibly with the wrong message, and that the second decodes the correct message, possibly while rejecting. Mathematically, it follows from the definition of the trace and the fact that for any positive semidefinite operator ρ on the appropriate spaces, such as $\rho = (D_k \otimes D_k) \circ A \circ E_k(m)$, it holds that

$$\begin{aligned} \langle m, 1, m, 1 | \rho | m, 1, m, 1 \rangle &\leq \sum_{m' \in \mathcal{M}} \sum_{b' \in \{0,1\}} \langle m', 1, m, b' | \rho | m', 1, m, b' \rangle \\ &= \langle 1, m | (\text{Tr}_{\mathbb{M}} \otimes \text{Id}_{\mathbb{F}} \otimes \text{Id}_{\mathbb{M}} \otimes \text{Tr}_{\mathbb{F}}) (\rho) | 1, m \rangle. \end{aligned} \quad (130)$$

By [Lemma 37](#) and the fact that S is δ -tamper-evident, we have that

$$\begin{aligned} \mathbb{E}_{\substack{k \leftarrow K(\varepsilon) \\ m \leftarrow \mathcal{M}}} \langle m | \left((\text{Tr}_M \circ \overline{D}_k) \otimes \tilde{D}_k \right) \circ A \circ E_k(m) | m \rangle &\leq \frac{1}{|\mathcal{M}|} (1 - 4\delta) + 4\delta \\ &\leq \frac{1}{|\mathcal{M}|} + 4\delta \end{aligned} \quad (131)$$

where, for simplicity, we neglect the $4\delta|\mathcal{M}|^{-1}$ term for the remainder of the proof.

We must now account for the possible deviation of the key generation procedures K' of $\text{QM}_{\sqrt{\varepsilon}}(S)$ from simply sampling m uniformly at random and k from $K(\varepsilon)$. For every key-message pair $(k, m) \in \mathcal{K}' = \mathcal{K} \times \mathcal{M}$, we have that

$$\langle k, m | K'(\varepsilon) | k, m \rangle = \begin{cases} \frac{\langle k, m | K(\varepsilon) | k, m \rangle}{\sum_{(k, m) \in \mathcal{G}} \langle k, m | K(\varepsilon) | k, m \rangle} & \text{if } (k, m) \in \mathcal{G} \\ 0 & \text{else.} \end{cases} \quad (132)$$

Hence, by [Lemma 38](#), we have that

$$\begin{aligned} &\mathbb{E}_{(k, m) \leftarrow K'(\varepsilon)} \langle m | \left((\text{Tr}_M \circ \overline{D}_k) \otimes \tilde{D}_k \right) \circ A \circ E_k(m) | m \rangle \\ &\leq \mathbb{E}_{\substack{k \leftarrow K(\varepsilon) \\ m \leftarrow \mathcal{M}}} \langle m | \left((\text{Tr}_M \circ \overline{D}_k) \otimes \tilde{D}_k \right) \circ A \circ E_k(m) | m \rangle + \left(1 - \Pr_{\substack{k \leftarrow K(\varepsilon) \\ m \leftarrow \mathcal{M}}} [(k, m) \in \mathcal{G}] \right) \\ &\leq \frac{1}{|\mathcal{M}|} + 4\delta + \left(1 - \Pr_{\substack{k \leftarrow K(\varepsilon) \\ m \leftarrow \mathcal{M}}} [(k, m) \in \mathcal{G}] \right) \\ &\leq \frac{1}{|\mathcal{M}|} + 4\delta + \sqrt{\varepsilon} \end{aligned} \quad (133)$$

where the last inequality is obtained by [Equation 128](#). This is the desired result. \square

On avoiding sampling from \mathcal{G} . As we have previously mentioned, we do not consider here the complexity of sampling key-message pairs from \mathcal{G} . If the complexity of this sampling would be problematic, we can modify our construction of $\text{QM}_\gamma(S)$ to avoid it. However, this comes at the cost of only achieving a weaker notion of correctness. Instead of achieving the notion of correctness we gave in [Definition 32](#), namely that

$$\langle k | K(\varepsilon) | k \rangle > 0 \implies \overline{V}_k \circ M(k) \geq 1 - \epsilon, \quad (134)$$

which is to say that *all* banknotes produced by the bank are accepted with high probability, we will only achieve

$$\mathbb{E}_{k \leftarrow K(\varepsilon)} \overline{V}_k \circ M(k) \geq 1 - \epsilon, \quad (135)$$

which is to say that banknotes are accepted, *on average*, with high probability. In particular, it may be possible for the bank to produce faulty banknotes which will not be accepted with any significant probability.

We denote our modified construction of a quantum money scheme from an AQECM scheme S by $\text{QM}_{\text{weak}}(S)$. This is exactly as the $\mathcal{G} \neq \emptyset$ case of $\text{QM}_\gamma(S)$ in [Definition 34](#),

except that key-message pairs (k, m) are always generated by sampling k according to the key generation channel S and sampling m uniformly at random from the messages of S . If S is an ϵ -correct δ -tamper-evident AQECM scheme, then it is straightforward to see that the quantum money scheme $\text{QM}_{\text{weak}}(S)$ is ϵ -correct according with respect to the weaker definition of correctness given in Equation 135 and that it is $(|\mathcal{M}|^{-1} + 4\delta)$ -secure by applying the proof of Theorem 39 but stopping at Equation 131.

6 Tamper Evidence, Revocation, and Certified Deletion

In this section, we explore the relation between tamper evidence and revocation schemes. A high-level overview of this section can be found in Section 1.2.3, our initial discussion in the introduction.

In Section 6.1 we review the syntax of a revocation scheme and we define the security of such schemes in Section 6.2. This includes our novel definition, the existing game-based definition, and proofs of the near equivalence of these two definitions. We give our construction of tamper-evident schemes from revocation schemes in Section 6.3.2 and our construction of revocation schemes from tamper-evident schemes in Section 6.3.1. Finally, in Section 6.4 we highlight that our results yield as an easy corollary that revocation implies encryption.

6.1 The Syntax of Revocation and Certified Deletion Schemes

Our first task in defining revocation and certified-deletion is to layout the syntax for schemes aiming to achieve this security notion. We formalize this syntax in Definition 40 as *quantum encryptions of classical messages with revocation* (QECMR) schemes, or simply *revocation schemes*, and note that it is essentially the same definition as the one given for *certified deletion encryption* schemes by Broadbent and Islam [BI20], modulo the fact that we move the definition from a computational setting to an information-theoretic setting.

A QECMR (K, E, D, R, V) is a QECM (K, E, D) equipped with two additional channels R and V . The first, R , is the *revocation* channel and is unkeyed. This is the channel which the receiver of the original message should use if the message is to be revoked or forfeited. It processes a ciphertext into a state which we will call a *revocation token*. The second channel, V , is the *verification* channel and it is keyed. This channel processes a revocation token with the help of a key and produces a single qubit indicating whether it accepts or rejects the revocation.

Definition 40. A *quantum encoding of classical messages with revocation* (QECMR) is a tuple (K, E, D, R, V) of channels such that (K, E, D) is a QECM as given in Definition 11 and V and R are of the form

$$R : \mathcal{L}(\mathbb{C}) \rightarrow \mathcal{L}(\mathbb{R}) \quad \text{and} \quad V : \mathcal{L}(\mathbb{K} \otimes \mathbb{R}) \rightarrow \mathcal{L}(\mathbb{F}) \quad (136)$$

for an alphabet \mathcal{R} and Hilbert spaces $\mathbb{R} = \mathbb{C}^{\mathcal{R}}$ and $\mathbb{F} = \mathbb{C}^{\{0,1\}}$. For all keys $k \in \mathcal{K}$, we also define the map $\bar{V}_k : \mathcal{L}(\mathbb{R}) \rightarrow \mathbb{C}$ by $\rho \mapsto \langle 1 | V(k \otimes \rho) | 1 \rangle$.

The correctness of a QECMR is quantified by a single value $\epsilon \in \mathbb{R}$ which is an upper bound on both (1) the probability over the key generation process that any message is not

correctly recovered after decryption and (2) the probability over the key generation process that any well formed revocation token is not accepted.²³ This is given in [Definition 41](#).

Definition 41. Let $\epsilon \in \mathbb{R}$. A QECMR as given in [Definition 40](#) is ϵ -correct if the QECM (K, E, D) is ϵ -correct and, for all messages $m \in \mathcal{M}$, we have that

$$\mathbb{E}_{k \leftarrow K(\epsilon)} \overline{V}_k \circ R \circ E_k(m) \geq 1 - \epsilon. \quad (137)$$

Certified deletion schemes as a subset of revocation schemes. We briefly comment on the distinction between a revocation scheme and a certified deletion scheme, but emphasize that this distinction is inconsequential for our work. Note that the previous definition does not require the revocation channel R to produce a classical output. While this property was not formally encoded in Broadbent and Islam’s original definition [[BI20](#)], it was explicitly emphasized in the surrounding discussion.

A natural way to enforce the requirement that the revocation map produces a classical output would be to require that $R = \Delta_{\mathcal{R}} \circ R$, which is to say that the output of R never changes if it is immediately measured in the computational basis. This is *not* what we will do here. Instead, we make a similar requirement on the verification map V .

Definition 42. A QECMR scheme as given in [Definition 40](#) is a *certified deletion scheme* if $V = V \circ (\text{Id}_{\mathcal{K}} \otimes \Delta_{\mathcal{R}})$.

We impose this condition on the *verification* map instead of the *revocation* map because, of the two, only the verification map appears in the upcoming security definitions. Hence, the condition “revocation tokens in a certified deletion scheme must be classical” needs to be encoded in the verification map for it to be relevant in the discussion of security. However, for honest users, there is no distinction between these two options. Indeed, if the verification map always begins with a computational basis measurement, the revocation map may as well output a classical state. Similarly, in this case, adversaries attempting to fool the verification map will gain no advantage in submitting a non-classical state. Mathematically, this is due to the fact that the computational basis measurement channel $\Delta_{\mathcal{R}}$ is idempotent, yielding, for any $k \in \mathcal{K}$, that $(V_k \circ \Delta_{\mathcal{R}}) \circ (\Delta_{\mathcal{R}} \circ R) = (V_k \circ \Delta_{\mathcal{R}}) \circ R = V_k \circ (\Delta_{\mathcal{R}} \circ R)$.

6.2 Defining Revocation Security

We give two definitions of revocation security for QECMR schemes and show that they are conceptually equivalent. The first, [Definition 43](#), is a novel formulation well suited for the information-theoretic regime and closely resembles Gottesman’s definition of tamper evidence. The second, [Definition 46](#), is essentially the one already found in the literature.

Our new definition inspired by tamper evidence. We begin by defining a *revocation* attack against an QECMR scheme. This is a channel which, on input of a ciphertext, aims to produce a revocation token which will be accepted while also keeping some information on the ciphertext.

²³One could quantify correctness for a QECMR with a *pair* of values, one bounding the probability of bad decryption and the other the probability of bad revocation. We do not need this level of granularity here.

Definition 43. A *revocation attack* against a QECCMR scheme as given in Definition 40 is a channel of the form $A : \mathcal{L}(C) \rightarrow \mathcal{L}(R \otimes A)$ for some Hilbert space A .

This is quite similar to the definition of a tamper attack $A : \mathcal{L}(C) \rightarrow \mathcal{L}(C \otimes A)$. The only difference is that the ciphertext space is the codomain is replaced with the revocation token space. Conceptually, there is also a close similarity: in both cases the adversary attempts to have an honest party accept a state while trying to obtain or keep information.

We now give our novel definition for revocation security, inspired by the definition of tamper evidence given in Definition 17. The only differences are that we substitute the decryption map of an AQECM with the verification map of a QECCMR and that we bound the *expectation* of the trace distance over the choice of keys instead of requiring that it is small with high probability over the choice of the keys.

Definition 44. Let $\delta \in \mathbb{R}$ and let (K, E, D, R, V) be a QECCMR scheme as given in Definition 40. This scheme has δ -revocation security if for any two messages $m, m' \in \mathcal{M}$ and any revocation attack A against it we have that

$$\mathbb{E}_{k \leftarrow K(\varepsilon)} \frac{1}{2} \left\| (\bar{V}_k \otimes \text{Id}_A) \circ A \circ E_k(m - m') \right\|_1 \leq \delta. \quad (138)$$

The existing game-based definition of revocation security. We now recall the game-based definition of security for revocation, which is stated in Definition 46. This will formalize the idea of the following game played between an adversary and a referee:

1. The adversary prepares a tripartite state over the space $M \otimes M \otimes A$. This should be understood as the adversary preparing two candidate messages m_0 and m_1 on the space $M \otimes M$ as well as keeping a memory state on the space A . The adversary then sends the $M \otimes M$ subsystem to the referee.
2. The referee samples a key $k \leftarrow K(\varepsilon)$, samples uniformly at random a bit $b \leftarrow \{0, 1\}$, and measures the received states on the $M \otimes M$ space in the computational basis to obtain a result (m_0, m_1) . Then, they return $E_k(m_b)$ to the adversary.
3. Acting on their memory state and the $E_k(m_b)$ state received from the referee, the adversary produces a bipartite state on $R \otimes A$ and sends the R subsystem to the referee. This should be understood as the adversary attempting to convince the referee that the ciphertext has been revoked while keeping some information.
4. The referee verifies the state returned by the adversary by applying V_k and measuring the resulting qubit in the computational basis. Call the result v .
5. The referee divulges the key k to the adversary, after which the adversary produces a guess $g \in \{0, 1\}$ for the value of b .

Conceptually, we understand the adversary to win if and only if they correctly guess the value of b and the referee accepted the revocation. In other words, the adversary wins if and only if $v = 1$ and $g = b$. We could then define the security of this scheme as the

advantage of the adversary in winning this game beyond the trivially achievable probability of $\frac{1}{2}$.

Instead, we take a slightly different approach and simply require that the adversary's output g does not depend much on b when $v = 1$. Formally, the scheme achieves δ -game-revocation security if the absolute value between $\mathbb{E}_{k \leftarrow K(\varepsilon)} \Pr[v = 1 \wedge g = 1 | b = 0]$ and $\mathbb{E}_{k \leftarrow K(\varepsilon)} \Pr[v = 1 \wedge g = 1 | b = 1]$, where the probability is taken over one execution of this game with the sampled key k , is at most δ . This is represented in [Table 1](#).

	Ref. Sampled $b = 0$		Ref. Sampled $b = 1$	
	Ref. Rej. ($v = 0$)	Ref. Acc. ($v = 1$)	Ref. Rej. ($v = 0$)	Ref. Acc. ($v = 1$)
Adv. Guessed $g = 0$				
Adv. Guessed $g = 1$		p_0		p_1

Table 1: Eight possible scenarios in a revocation game. For both values of $b' \in \{0, 1\}$, we let $p_{b'} = \Pr[g = 1 \wedge v = 1 | b = b']$ and identify these events in the table.

We formalize this game and security statement in the following two definitions. In order to differentiate from our previously defined notions of revocation attacks and revocation security, we will use the terms *game-revocation attack* and *game-revocation security* here.

Definition 45. Let (K, E, D, V, R) be a QECMR as given in [Definition 40](#). A *game-revocation attack* against this scheme is a triplet of channel (A^0, A^1, A^2) of the form

$$\begin{aligned}
A^0 &: \mathcal{L}(\mathbb{C}) \rightarrow \mathcal{L}(\mathbb{M} \otimes \mathbb{M} \otimes \mathbb{A}) \\
A^1 &: \mathcal{L}(\mathbb{C} \otimes \mathbb{A}) \rightarrow \mathcal{L}(\mathbb{R} \otimes \mathbb{A}) \\
A^2 &: \mathcal{L}(\mathbb{K} \otimes \mathbb{A}) \rightarrow \mathcal{L}(\mathbb{C}^{\{0,1\}})
\end{aligned} \tag{139}$$

for some Hilbert space \mathbb{A} .

For every key $k \in \mathcal{K}$, we also define the map $A_k^2 : \mathcal{L}(\mathbb{A}) \rightarrow \mathcal{L}(\mathbb{C}^{\{0,1\}})$ by $\rho \mapsto A^2(k \otimes \rho)$.

Note that A^0 , A^1 , and A^2 model, respectively, the actions taken by the adversary in steps 1, 3, and 5 of the game we described.

Definition 46. Let $S = (K, E, D, V, R)$ be a QECMR scheme as given in [Definition 40](#). For all keys $k \in \mathcal{K}$, we define the channels

$$E_k^0 = E_k \circ (\Delta_{\mathcal{M}} \otimes \text{Tr}_{\mathbb{M}}) \quad \text{and} \quad E_k^1 = E_k \circ (\text{Tr}_{\mathbb{M}} \otimes \Delta_{\mathcal{M}}) \tag{140}$$

which is to say that for both $b \in \{0, 1\}$, E_k^b measures its input in the computational basis to obtain an outcome (m_0, m_1) and then outputs $E_k(m_b)$.

The scheme S has δ -*game-revocation security* if for all game-revocation attacks (A^0, A^1, A^2) against it we have that

$$\left| \mathbb{E}_{k \leftarrow K(\varepsilon)} \langle 1 | A_k^2 \circ (\overline{V}_k \otimes \text{Id}_{\mathbb{A}}) \circ A^1 \circ ((E_k^0 - E_k^1) \otimes \text{Id}_{\mathbb{A}}) \circ A^0(\varepsilon) | 1 \rangle \right| \leq \delta. \tag{141}$$

This is essentially the definition of certified deletion given by Broadbent and Islam [BI20] and of revocation given by Unruh [Unr15]. The main difference is that we do not state this definition in an asymptotic regime; instead of requiring the adversaries to have an advantage at most negligible in a security parameter, we say that the scheme achieves δ -security if their advantage is at most δ . We also differ from Broadbent and Islam as we require the adversary to initially submit *two* messages. Their definition only considered cases where the message space was the set of bit strings of a fixed length and fixed the second message which the referee could use to be the all-zero bit string. In our setting, where we do not impose such restrictions on the message space, it is more natural to let the adversary submit two messages than to have a definition which depends on the referee’s alternative message.

Another game-based definition. A slightly different game-based definition of revocation security has also been given in the work of Hiroka, Morimae, Nishimaki, and Yamakawa [HMNY21] on certified deletion. In their definition, the adversary does not need the referee to accept the revocation token to win the game. However, the adversary is given the key in step 5 if and only if the referee accepts this token. If the referee does not accept, then the adversary must generate their guess g without knowledge of the key k . Evidently, a QECMR scheme achieving a good level of revocation security with respect to the game of Hiroka *et al.* must also be a good encryption scheme. Indeed, if the scheme was not a good encryption scheme, then an adversary could distinguish the two ciphertexts without needing the key, and hence would be able to win the game without even trying to obtain the key. Thus, the Hiroka *et al.* definition has the advantages of covering two security notions, encryption and revocation, in a single security game and may better reflect certain use cases. However, it does have certain theoretical drawbacks.

One such drawback is that analysing the revocation security of a QECMR scheme with respect to this definition is a bit more involved than with respect to Definition 46. Indeed, we must now consider the adversary’s guessing strategy in two very distinct cases: in the case where they do get the key, and in the case where they do not.

A second drawback is that this definition ties together two security notions, encryption and revocation, which *a priori* are distinct. For example, not every encryption scheme allows revocation. This grouping of encryption and revocation hinders a more fine-grained study of these security notions. For example, is it possible to achieve revocation without encryption? With respect to their definition, the answer is trivially “no”. On the other hand, this is a non-trivial question with respect to Definition 46, even if we show later in Section 6.4 that the answer remains “no”. We believe that it is theoretically more interesting to know that revocation security implies encryption by necessity, and not simply by definition.

The near equivalence of these two definitions. As we have introduced in Definition 44 a new formulation of revocation security, we have a responsibility to show how it relates to the existing definition. We show that there is at most a factor of two difference between the revocation security and game-revocation security achieved by any given QECMR scheme. More precisely, we show in Theorem 47 that δ -revocation implies 2δ -game-revocation and in Theorem 48 that δ -game-revocation implies δ -revocation. In other words, if a scheme

has δ_r -revocation and δ_{gr} -game-revocation security, then

$$\delta_r \leq \delta_{\text{gr}} \leq 2\delta_r \quad \text{or, equivalently,} \quad \frac{1}{2}\delta_{\text{gr}} \leq \delta_r \leq \delta_{\text{gr}}. \quad (142)$$

This factor of two between upper and lower bounds may be a proof artefact. However, it seems to be closely related to the fact that the inequality $|\langle 1 | \Phi(\rho - \sigma) | 1 \rangle| \leq \frac{1}{2} \|\rho - \sigma\|_1$ for a channel Φ may not hold if ρ or σ are subnormalized operators. In the discussion surrounding [Lemma 3](#), we noted that the correct inequality in this case is $|\langle 1 | \Phi(\rho - \sigma) | 1 \rangle| \leq \|\rho - \sigma\|_1$, namely that the upper bound must be multiplied by a factor of two to hold.

Theorem 47. A QECMR with δ -revocation security has 2δ -game-revocation security.

Proof. Let (K, E, D, V, R) be a QECMR as given in [Definition 40](#) and let (A^0, A^1, A^2) be a game-revocation attack against this scheme as given in [Definition 45](#). The first step of this proof is to eliminate the roles of the A^0 and A^2 channels and identify the remaining A^1 channel with a revocation attack as considered in [Definition 44](#).

Recall that the quantity to bound is

$$\left| \mathbb{E}_{k \leftarrow K(\varepsilon)} \langle 1 | A_k^2 \circ (\bar{V}_k \otimes \text{Id}_A) \circ A^1 \circ ((E_k^0 - E_k^1) \otimes \text{Id}_A) \circ A^0(\varepsilon) | 1 \rangle \right|. \quad (143)$$

We begin by eliminating A^2 . By the triangle inequality and [Lemma 3](#), which tells us that $|\langle 1 | \Phi(A - B) | 1 \rangle| \leq \|A - B\|_1$ if Φ is a channel and $A - B$ is Hermitian, we have that

$$\begin{aligned} & \left| \mathbb{E}_{k \leftarrow K(\varepsilon)} \langle 1 | A_k^2 \circ (\bar{V}_k \otimes \text{Id}_A) \circ A^1 \circ ((E_k^0 - E_k^1) \otimes \text{Id}_A) \circ A^0(\varepsilon) | 1 \rangle \right| \\ & \leq \mathbb{E}_{k \leftarrow K(\varepsilon)} |\langle 1 | A_k^2 \circ (\bar{V}_k \otimes \text{Id}_A) \circ A^1 \circ ((E_k^0 - E_k^1) \otimes \text{Id}_A) \circ A^0(\varepsilon) | 1 \rangle| \\ & \leq \mathbb{E}_{k \leftarrow K(\varepsilon)} \|(\bar{V}_k \otimes \text{Id}_A) \circ A^1 \circ ((E_k^0 - E_k^1) \otimes \text{Id}_A) \circ A^0(\varepsilon)\|_1. \end{aligned} \quad (144)$$

Next, we eliminate A^0 . By definition, we have that

$$((E_k^0 - E_k^1) \otimes \text{Id}_A) \circ A^0 = E_k \circ ((\text{Id}_M \otimes \text{Tr}_M) - (\text{Tr}_M \otimes \text{Id}_M)) \circ (\Delta_{\mathcal{M}} \otimes \Delta_{\mathcal{M}}) \circ A^0 \quad (145)$$

and we can write

$$(\Delta_{\mathcal{M}} \otimes \Delta_{\mathcal{M}}) \circ A^0(\varepsilon) = \sum_{m, m' \in \mathcal{M}} p_{m, m'} \cdot m \otimes m' \otimes \sigma_{m, m'} \quad (146)$$

where the $p_{m, m'}$ terms are non-negative reals which sum to 1 and $\sigma_{m, m'} \in \mathcal{D}(A)$ is the state of the adversarial memory register A if (m, m') is the result of the measurement. Thus,

$$((E_k^0 - E_k^1) \otimes \text{Id}_A) \circ A^0(\varepsilon) = \sum_{m, m' \in \mathcal{M}} p_{m, m'} \cdot E_k(m - m') \otimes \sigma_{m, m'} \quad (147)$$

and so

$$\begin{aligned} & \mathbb{E}_{k \leftarrow K(\varepsilon)} \|(\bar{V}_k \otimes \text{Id}_A) \circ A^1 \circ ((E_k^0 - E_k^1) \otimes \text{Id}_A) \circ A^0(\varepsilon)\|_1 \\ & = \mathbb{E}_{k \leftarrow K(\varepsilon)} \left\| \sum_{m, m' \in \mathcal{M}} p_{m, m'} (\bar{V}_k \otimes \text{Id}_A) \circ A^1 \left((E_k(m - m')) \otimes \sigma_{m, m'} \right) \right\|_1. \end{aligned} \quad (148)$$

Using the triangle inequality, we can upper bound the values of the previous equation by

$$\begin{aligned} & \sum_{m,m' \in \mathcal{M}} p_{m,m'} \mathbb{E}_{k \leftarrow K(\varepsilon)} \left\| (\bar{V}_k \otimes \text{Id}_A) \circ A^1 \left((E_k(m - m')) \otimes \sigma_{m,m'} \right) \right\|_1 \\ &= \sum_{m,m' \in \mathcal{M}} p_{m,m'} \mathbb{E}_{k \leftarrow K(\varepsilon)} \left\| (\bar{V}_k \otimes \text{Id}_A) \circ A'_{m,m'} \circ E_k(m - m') \right\|_1 \end{aligned} \quad (149)$$

where, for every $m, m' \in \mathcal{M}$, we define the channel $A'_{m,m'}$ by $\rho \mapsto A^1(\rho \otimes \sigma_{m,m'})$. Note that the channel $A'_{m,m'}$ is a revocation attack. As we assume that the QECMR scheme has δ -revocation security, we have by definition that

$$\mathbb{E}_{k \leftarrow K(\varepsilon)} \frac{1}{2} \left\| (\bar{V}_k \otimes \text{Id}_A) \circ A'_{m,m'} \circ E_k(m - m') \right\|_1 \leq \delta \quad (150)$$

for all $m, m' \in \mathcal{M}$ and so

$$\sum_{m,m'} p_{m,m'} \mathbb{E}_{k \leftarrow K(\varepsilon)} \left\| (\bar{V}_k \otimes \text{Id}_A) \circ A'_{m,m'} \circ E_k(m - m') \right\|_1 \leq \sum_{m,m'} p_{m,m'} 2\delta = 2\delta \quad (151)$$

which, with [Equation 144](#), yields the desired result. \square

We now move on to show that δ -game-revocation security implies δ -revocation security. We do this by transforming an revocation attack A and pair of messages (m, m') into a game-revocation attack (A^0, A^1, A^2) . Essentially, A^0 simply generates the state $m \otimes m'$ as the candidate messages for the referee, A^1 is taken to be A , and A^2 is an optimal distinguishing channel for the two possible states held by the adversary. For technical reasons, namely to saturate the first bound in [Lemma 3](#), we also need to consider a closely related game-revocation attack $(A^0, A^1, A^2_{\text{Flip}})$ which simply flips the guess of A^2 .

Theorem 48. A QECMR with δ -game-revocation security has δ -revocation security.

Proof. Let (K, E, D, V, R) be a QECMR as given in [Definition 40](#). For any revocation attack $A : \mathcal{L}(\mathbb{C}) \rightarrow \mathcal{L}(\mathbb{R} \otimes A)$ and any two messages $m, m' \in \mathcal{M}$, we define the game-revocation attack (A^0, A^1, A^2) as follows:

- The channel $A^0 : \mathbb{C} \rightarrow \mathcal{L}(\mathbb{C} \otimes \mathbb{C} \otimes A)$ is defined by $c \mapsto c \left(m \otimes m' \otimes \frac{I_A}{\dim A} \right)$.

The final term in this tensor product is there merely because the syntax requires A^0 to include the A space in its output. It will be promptly deleted and replaced by A^1 .

- The channel $A^1 : \mathcal{L}(\mathbb{C} \otimes A) \rightarrow \mathcal{L}(\mathbb{R} \otimes A)$ is defined by $A^1 = A \circ (\text{Id}_{\mathbb{C}} \otimes \text{Tr}_A)$, which is to say that it simply applies the revocation attack A .
- The channel $A^2 : \mathcal{L}(\mathbb{K} \otimes A) \rightarrow \mathcal{L}(\mathbb{C}^{\{0,1\}})$ is any channel which satisfies

$$\begin{aligned} & \sum_{b \in \{0,1\}} \left| \langle b | A^2 \left(\mathbb{E}_{k \leftarrow K(\varepsilon)} k \otimes \bar{V}_k \circ A \circ E_k(m - m') \right) | b \rangle \right| \\ &= \left\| \mathbb{E}_{k \leftarrow K(\varepsilon)} k \otimes \bar{V}_k \circ A \circ E_k(m - m') \right\|_1 \end{aligned} \quad (152)$$

which is to say that A^2 is an optimal channel to distinguish between the possible outputs of A^1 when given the key k . Such a channel exists by [Lemma 3](#).

We also define $A_{\text{Flip}}^2 : \mathcal{L}(\mathbb{K} \otimes \mathbb{C}) \rightarrow \mathcal{L}(\mathbb{C}^{\{0,1\}})$ by $\rho \mapsto (|1\rangle\langle 0| + |0\rangle\langle 1|)A^2(\rho)(|1\rangle\langle 0| + |0\rangle\langle 1|)$, which is to say that A_{Flip}^2 is simply A^2 followed by a bit flip operation. In particular, it holds that $\langle 1|A_{\text{Flip}}^2(\rho)|1\rangle = \langle 0|A^2(\rho)|0\rangle$ for any linear operator ρ . Note that $(A^0, A^1, A_{\text{Flip}}^2)$ is also a game-revocation attack. We examine the performance of both these attacks.

By the definition of A^0 and A^1 , we have that

$$A^1 \circ ((E_k^0 - E_k^1) \otimes \text{Id}_A) \circ A^0(\varepsilon) = A \circ E_k(m - m') \quad (153)$$

and so, summing over both attacks, we see that

$$\begin{aligned} & \sum_{C \in \{A^2, A_{\text{Flip}}^2\}} \left| \mathbb{E}_{k \leftarrow K(\varepsilon)} \langle 1| C_k \circ (\overline{V}_k \otimes \text{Id}_A) \circ A^1 \circ ((E_k^0 - E_k^1) \otimes \text{Id}_A) \circ A^0(\varepsilon) |1\rangle \right| \\ &= \sum_{C \in \{A^2, A_{\text{Flip}}^2\}} \left| \mathbb{E}_{k \leftarrow K(\varepsilon)} \langle 1| C_k \circ (\overline{V}_k \otimes \text{Id}_A) \circ A \circ E_k(m - m') |1\rangle \right| \\ &= \sum_{C \in \{A^2, A_{\text{Flip}}^2\}} \left| \langle 1| C \left(\mathbb{E}_{k \leftarrow K(\varepsilon)} k \otimes (\overline{V}_k \otimes \text{Id}_A) \circ A \circ E_k(m - m') \right) |1\rangle \right| \\ &= \sum_{b \in \{0,1\}} \left| \langle b| A^2 \left(\mathbb{E}_{k \leftarrow K(\varepsilon)} k \otimes (\overline{V}_k \otimes \text{Id}_A) \circ A \circ E_k(m - m') \right) |b\rangle \right| \\ &= \left\| \mathbb{E}_{k \leftarrow K(\varepsilon)} k \otimes (\overline{V}_k \otimes \text{Id}_A) \circ A \circ E_k(m - m') \right\|_1 \\ &= \mathbb{E}_{k \leftarrow K(\varepsilon)} \left\| (\overline{V}_k \otimes \text{Id}_A) \circ A \circ E_k(m - m') \right\|_1 \end{aligned} \quad (154)$$

where the first three equalities follow from the definitions of the various maps, the fourth from the defining property of A^2 , and the fifth from [Lemma 6](#) which states a technical property of the Schatten 1-norm.

As the scheme is assumed to be δ -game-revocation secure, both of the initial absolute values is upper-bounded by δ . Hence, $\mathbb{E}_{k \leftarrow K(\varepsilon)} \left\| (\overline{V}_k \otimes \text{Id}_A) \circ A \circ E_k(m - m') \right\|_1 \leq 2\delta$ which yields the desired result after dividing both sides by two. \square

6.3 From Revocation to Tamper Evidence and Back

We show here how to construct a revocation scheme from a tamper-evident scheme ([Section 6.3.1](#)) and vice-versa ([Section 6.3.2](#)). The intuition for these constructions can be conveyed by recalling and directly comparing the inequalities defining the two relevant security guarantees.

As stated in [Definition 17](#), an AQECM scheme is δ -tamper-evident if and only if for all channels $A : \mathcal{L}(\mathbb{C}) \rightarrow \mathcal{L}(\mathbb{C} \otimes \mathbb{A})$ and all messages $m, m' \in \mathcal{M}$ we have that

$$\Pr_{k \leftarrow K(\varepsilon)} \left[\frac{1}{2} \left\| ((\text{Tr}_M \circ \overline{D}_k) \otimes \text{Id}_A) \circ A \circ E_k(m - m') \right\|_1 \leq \delta \right] \geq 1 - \delta. \quad (155)$$

As stated in [Definition 44](#), a QECCMR scheme has δ -revocation security if and only if for all channels $A : \mathcal{L}(\mathbb{C}) \rightarrow \mathcal{L}(\mathbb{R} \otimes \mathbb{A})$ and all messages $m, m' \in \mathcal{M}$ we have that

$$\mathbb{E}_{k \leftarrow \kappa} \frac{1}{2} \left\| (\overline{V}_k \otimes \text{Id}_A) \circ A \circ E_k(m - m') \right\|_1 \leq \delta. \quad (156)$$

The striking similarity between these two security guarantees is that they are both statements on the trace distance between subnormalized states held by an adversary, conditioned on an honest receiver accepting what the adversary gave them.

We acknowledge one difference, namely that revocation security is expressed as a bound on the *expected* trace distance while tamper evidence states that with *high probability over the choice of keys* the trace distance is small. However, using the concentration inequality given in [Lemma 2](#), we can shift between both types of statements with ease.

6.3.1 Revocation From Tamper Evidence

We show here how to construct a QECCMR which is ϵ -correct and has 2δ -revocation security from any ϵ -correct δ -tamper-evident AQECM.

Our construction, which we denote $S \mapsto \text{Rev}(S)$, is quite simple. It suffices to note that in an AQECM scheme the decoding and verification of a ciphertext are done by the same channel, but that in a QECCMR these tasks are accomplished by different channels. Thus, we can obtain the decoding and revocation maps of the QECCMR by simply using the decoding map of the AQECM and keeping only the appropriate output. Finally, the revocation map is the identity, which is to say that the original recipient simply returns the ciphertext unmodified during the revocation protocol. This is formalized in [Definition 49](#).

Definition 49. Let $S = (K, E, D)$ be an AQECM scheme as given in [Definition 13](#). We define $\text{Rev}(S) = (K', E', D', R', V')$ by $K' = K$, $E' = E$, $R = \text{Id}_{\mathcal{C}}$, as well as

$$D' = (\text{Id}_{\mathcal{M}} \otimes \text{Tr}_{\mathcal{F}}) \circ D, \quad \text{and} \quad V' = (\text{Tr}_{\mathcal{M}} \otimes \text{Id}_{\mathcal{F}}) \circ D. \quad (157)$$

Note that $\text{Rev}(S)$ is a QECCMR with the same keys and messages as S .

We show in the following theorem that $\text{Rev}(S)$ inherits the correctness of S .

Theorem 50. If S is an ϵ -correct AQECM, then $\text{Rev}(S)$ is an ϵ -correct QECCMR.

Proof. Let S be an AQECM as given in [Definition 13](#) and let $\text{Rev}(S)$ be a QECCMR as given in [Definition 49](#). For any message $m \in \mathcal{M}$, we have that

$$\begin{aligned} \mathbb{E}_{k \leftarrow K'(\epsilon)} \langle m | D'_k \circ E'_k(m) | m \rangle &= \mathbb{E}_{k \leftarrow K(\epsilon)} \langle m | (\text{Id}_{\mathcal{M}} \otimes \text{Tr}_{\mathcal{F}}) \circ D_k \circ E_k(m) | m \rangle \\ &\geq \mathbb{E}_{k \leftarrow K(\epsilon)} \langle m | \overline{D}_k \circ E_k(m) | m \rangle \\ &\geq 1 - \epsilon \end{aligned} \quad (158)$$

where the equality follows from the definition of $\text{Rev}(S)$, the first inequality by replacing the trace with the map $\rho \mapsto \langle 1 | \rho | 1 \rangle$, and the second by the assumption that S is ϵ -correct. Similarly, for any message $m \in \mathcal{M}$, we have that

$$\begin{aligned} \mathbb{E}_{k \leftarrow K'(\epsilon)} \overline{V}'_k \circ R \circ E'_k(m) &= \mathbb{E}_{k \leftarrow K(\epsilon)} \text{Tr}_{\mathcal{M}} \circ \overline{D}_k \circ E_k(m) \\ &\geq \mathbb{E}_{k \leftarrow K(\epsilon)} \langle m | \overline{D}_k \circ E_k(m) | m \rangle \\ &\geq 1 - \epsilon. \end{aligned} \quad (159)$$

Thus, we can conclude that $\text{Rev}(S)$ is an ϵ -correct QECCMR scheme. \square

Finally, we show that if S is δ -tamper evident, then $\text{Rev}(S)$ has 2δ -revocation security. The factor of two loss in security is incurred by passing from a concentration inequality in the definition of tamper evidence to an expectation in the definition of revocation security, as illustrated in [Lemma 21](#).

Theorem 51. $\text{Rev}(S)$ has 2δ -revocation security if S is a δ -tamper-evident AQECM.

Proof. We can assume that $0 \leq \delta < \frac{1}{2}$ as the result is trivially true if $\delta \geq \frac{1}{2}$ and there are no δ -tamper-evident schemes if $\delta < 0$.

By definition of $\text{Rev}(S)$, specifically that $R' = \text{Id}_{\mathbb{C}}$, revocation tokens are simply ciphertexts from S . This implies that the Hilbert space \mathbb{R} is equal to \mathbb{C} . Thus, any revocation attack $A : \mathcal{L}(\mathbb{C}) \rightarrow \mathcal{L}(\mathbb{R} \otimes \mathbb{A})$ against $\text{Rev}(S)$ is also a tamper-attack against S .

Since S is δ -tamper-evident, for any two messages $m, m' \in \mathcal{M}$ it holds by [Lemma 21](#) that

$$\mathbb{E}_{k \leftarrow K(\varepsilon)} \frac{1}{2} \left\| \left((\text{Tr}_{\mathbb{M}} \circ \overline{D}_k) \otimes \text{Id}_{\mathbb{A}} \right) \circ A \circ E_k(m - m') \right\|_1 \leq 2\delta - \delta^2 \quad (160)$$

which implies, after substituting in the channels of $\text{Rev}(S)$, that

$$\mathbb{E}_{k \leftarrow K'(\varepsilon)} \frac{1}{2} \left\| \left(\overline{V}'_k \otimes \text{Id}_{\mathbb{A}} \right) \circ A \circ E'_k(m - m') \right\|_1 \leq 2\delta - \delta^2 \quad (161)$$

which is sufficient to obtain that $\text{Rev}(S)$ has 2δ -revocation security. \square

6.3.2 Tamper Evidence From Revocation

We show here how to construct an AQECM which is $2\sqrt[4]{\varepsilon}$ -correct and $\sqrt{\delta}$ -tamper evident from any QECMR which is ε -correct and has δ -revocation security. We denote the construction $S \mapsto \text{TE}(S)$.

The main idea of this construction is for the recipient in the tamper-evident setting to try to detect meaningful eavesdropping by running the complete revocation protocol of the original revocation scheme, namely $V \circ (\text{Id}_{\mathbb{K}} \otimes R)$, on their side upon reception of the ciphertext. They accept the ciphertext if and only if this revocation protocol accepts. This leads to an obvious problem: how can they then recover the plaintext if they have run the revocation protocol?

The solution is for the recipient to actually use the *coherent gentle measurement* version of $V \circ (\text{Id}_{\mathbb{K}} \otimes R)$, namely $\text{CGM}(V \circ (\text{Id}_{\mathbb{K}} \otimes R))$ as described in [Definition 8](#). The resulting channel produces as output a state on the ciphertext space as well as a single qubit flag where the resulting ciphertext state should be quite close to the original one, provided that it was very likely for the revocation protocol to accept. The recipient can then subsequently recover the plaintext by applying the decryption map of the QECMR scheme to this ciphertext state.

This construction is formalized in the following definition.

Definition 52. Let $S = (K, E, D, V, R)$ be a QECMR scheme as given in [Definition 40](#). We define the AQECM $\text{TE}(S) = (K', E', D')$ by

$$K' = K, \quad E' = E, \quad \text{and} \quad D' = (D \otimes \text{Id}_{\mathbb{F}}) \circ \text{CGM}(V \circ (\text{Id}_{\mathbb{K}} \otimes R)). \quad (162)$$

We now show the correctness of $\text{TE}(S)$.

Theorem 53. Let S be an ϵ -correct QECCMR. Then, $\text{TE}(S)$ is a $2\sqrt[4]{\epsilon}$ -correct AQECM

Proof. Let $S = (K, E, D, V, R)$ be an ϵ -correct QECCMR as given in Definition 40. We assume that $0 \leq \epsilon < \frac{1}{16}$ as there is no QECCMR which is ϵ' -correct if $\epsilon' < 0$ and the result is trivially true if $\epsilon \geq \frac{1}{16}$. Let $\text{TE}(S) = (K', E', D')$ be as given in Definition 52.

Recall that correctness for a QECCMR considers the correctness of decoding the proper message and the correctness of accepting an honest revocation separately. In particular, there is *a priori* no guarantee that a message m which correctly encodes and decodes with the key k will have its revocation with the same key accepted with high probability. However, correctness for an AQECM considers both the correct decoding and the acceptance simultaneously.

The fact that the QECCMR S is ϵ -correct means that

$$\mathbb{E}_{k \leftarrow K(\epsilon)} \langle 1 | V_k \circ R \circ E_k(m) | 1 \rangle \geq 1 - \epsilon \quad \text{and} \quad \mathbb{E}_{k \leftarrow K(\epsilon)} \langle m | D_k \circ E_k(m) | m \rangle \geq 1 - \epsilon \quad (163)$$

for any message $m \in \mathcal{M}$. With the concentration inequality of Lemma 2 and the union bound, this implies that for any $m \in \mathcal{M}$ it holds that

$$\Pr_{k \leftarrow K(\epsilon)} \left[\begin{array}{c} \langle 1 | V_k \circ R \circ E_k(m) | 1 \rangle \geq 1 - \sqrt{\epsilon} \\ \wedge \\ \langle m | D_k \circ E_k(m) | m \rangle \geq 1 - \sqrt{\epsilon} \end{array} \right] \geq 1 - 2\sqrt{\epsilon}. \quad (164)$$

Let $\mathcal{G}_m \subseteq \mathcal{K}$ be the set of keys satisfying the conditions in this probability statement. Note that $1 - 2\sqrt{\epsilon} > 0$ as $\epsilon < 1/4$ and so $\mathcal{G}_m \neq \emptyset$. Note that this set depends, in general, on m .

By definition of E' and D' , we have for any message $m \in \mathcal{M}$ and key $k \in \mathcal{K}$ that

$$\langle m | \overline{D}'_k \circ E'_k(m) | m \rangle = (\langle m | \otimes \langle 1 |) (D \otimes \text{Id}_{\mathbb{F}}) \circ \text{CGM}(V \circ (\text{Id}_{\mathbb{K}} \otimes R)) (k \otimes E_k(m)) (|m\rangle \otimes |1\rangle). \quad (165)$$

We begin by examining $\text{CGM}(V \circ (\text{Id}_{\mathbb{K}} \otimes R))(k \otimes E_k(m))$ under the assumption that $k \in \mathcal{G}_m$. Under this assumption, we have that

$$\langle 1 | (V \circ (\text{Id}_{\mathbb{K}} \otimes R))(k \otimes E_k(m)) | 1 \rangle = \langle 1 | V_k \circ R \circ E_k(m) | 1 \rangle \geq 1 - \sqrt{\epsilon} \quad (166)$$

and so, by the properties of the CGM map established in Theorem 10, it follows that

$$\frac{1}{2} \|\text{CGM}(V \circ (\text{Id}_{\mathbb{K}} \otimes R))(k \otimes E_k(m)) - k \otimes E_k(m) \otimes |1\rangle\langle 1|\|_1 \leq \sqrt{1 - (1 - \sqrt{\epsilon})^2} = \sqrt{2\sqrt{\epsilon} - \epsilon}. \quad (167)$$

We can substitute $\text{CGM}(V \circ (\text{Id}_{\mathbb{K}} \otimes R))(k \otimes E_k(m))$ with the state $k \otimes E_k(m) \otimes |1\rangle\langle 1|$ in the right-hand side of Equation 165 and its value will change by at most $\sqrt{2\sqrt{\epsilon} - \epsilon}$.²⁴ Thus,

$$\begin{aligned} & (\langle m | \otimes \langle 1 |) (D \otimes \text{Id}_{\mathbb{F}}) \circ \text{CGM}(V \circ (\text{Id}_{\mathbb{K}} \otimes R)) (k \otimes E_k(m)) (|m\rangle \otimes |1\rangle) \\ & \geq (\langle m | \otimes \langle 1 |) (D \otimes \text{Id}_{\mathbb{F}}) (k \otimes E_k(m) \otimes |1\rangle\langle 1|) (|m\rangle \otimes |1\rangle) - \sqrt{2\sqrt{\epsilon} - \epsilon} \\ & = \langle m | D(k \otimes E_k(m)) | m \rangle - \sqrt{2\sqrt{\epsilon} - \epsilon} \\ & \geq 1 - \sqrt{\epsilon} - \sqrt{2\sqrt{\epsilon} - \epsilon} \end{aligned} \quad (168)$$

²⁴That the change in the inner product following such a substitution can be controlled by the trace distance is well known. It can be recovered as a corollary to the second remark after Lemma 3 and considering, in this case, the channel $\Phi = \text{Ms}(\mu)$ where $\mu = \{0, 1\} \rightarrow \text{Pos}(\mathbb{M} \otimes \mathbb{C}^{\{0,1\}})$ is the measurement defined by $\mu(1) = |m\rangle\langle m| \otimes |1\rangle\langle 1|$ and $\mu(0) = I_{\mathbb{M} \otimes \mathbb{C}^{\{0,1\}}} - \mu(1)$.

where the final inequality is obtained by the assumption that $\langle m | D_k \circ E_k(m) | m \rangle \geq 1 - \sqrt{\epsilon}$ since $k \in \mathcal{G}_m$.

Finally, we have to account for the cases where $k \notin \mathcal{G}_m$. We have that

$$\begin{aligned}
\mathbb{E}_{k \leftarrow K'(\epsilon)} \langle m | \overline{D}'_k \circ E'_k(m) | m \rangle &\geq \Pr_{k \leftarrow K(\epsilon)} [k \in \mathcal{G}_m] \cdot \left(1 - \sqrt{\epsilon} - \sqrt{2\sqrt{\epsilon} - \epsilon} \right) \\
&\geq (1 - 2\sqrt{\epsilon}) \left(1 - \sqrt{\epsilon} - \sqrt{2\sqrt{\epsilon} - \epsilon} \right) \\
&= 1 - \underbrace{\sqrt[4]{\epsilon} \left((1 - 2\sqrt{\epsilon}) \sqrt{2 - \sqrt{\epsilon}} - 2\epsilon^{3/4} + 3\sqrt[4]{\epsilon} \right)}_{=g(\epsilon)} \\
&\geq 1 - 2\sqrt[4]{\epsilon}
\end{aligned} \tag{169}$$

where the factor of 2 results from maximizing $g(\epsilon)$ over all values $0 \leq \epsilon \leq \frac{1}{16}$. Noting that this holds for all $m \in \mathcal{M}$ completes the proof. \square

We now show that if S has δ -revocation security, then $\text{TE}(S)$ is $\sqrt{\delta}$ -tamper evident. We begin with a technical lemma making explicit a relation between the maps of these schemes.

Lemma 54. Let $S = (K, E, D, V, R)$ be a QECCMR scheme as given in Definition 40 and let $S' = \text{TE}(S) = (K', E', D')$ be an AQECM as given in Definition 52. Then, for any key $k \in \mathcal{K}$, we have that

$$\text{Tr}_{\mathcal{M}} \circ \overline{D}'_k = \overline{V}_k \circ R. \tag{170}$$

Proof. Let $\rho \in \mathcal{L}(\mathcal{C})$ be a linear operator. Then, by definition of D' , we have that

$$\begin{aligned}
\text{Tr}_{\mathcal{M}} \circ \overline{D}'_k(\rho) &= \text{Tr}_{\mathcal{M}} \left((I_{\mathcal{M}} \otimes \langle 1 |) D'(k \otimes \rho) (I_{\mathcal{M}} \otimes |1\rangle) \right) \\
&= \text{Tr}_{\mathcal{M}} \left((I_{\mathcal{M}} \otimes \langle 1 |) (D \otimes \text{Id}_{\mathcal{F}}) \circ \text{CGM}(V \circ (\text{Id}_{\mathcal{K}} \otimes R))(k \otimes \rho) (I_{\mathcal{M}} \otimes |1\rangle) \right)
\end{aligned} \tag{171}$$

and if we let $C_{\langle 1 |} : \mathcal{L}(\mathcal{F}) \rightarrow \mathbb{C}$ be defined by $\sigma \mapsto \langle 1 | \sigma |1\rangle$, we find that

$$(\text{Tr}_{\mathcal{M}} \otimes C_{\langle 1 |}) \circ (D \otimes \text{Id}_{\mathcal{F}}) = (\text{Tr}_{\mathcal{M}} \circ D) \otimes C_{\langle 1 |} = \text{Tr}_{\mathcal{K} \otimes \mathcal{C}} \otimes C_{\langle 1 |} = C_{\langle 1 |} \circ (\text{Tr}_{\mathcal{K} \otimes \mathcal{C}} \otimes \text{Id}_{\mathcal{F}})$$

which allows us to continue the previous equation as

$$= \langle 1 | (\text{Tr}_{\mathcal{K} \otimes \mathcal{C}} \otimes \text{Id}_{\mathcal{F}}) \circ \text{CGM}(V \circ (\text{Id}_{\mathcal{K}} \otimes R))(k \otimes \rho) |1\rangle \tag{172}$$

which, by properties of the CGM map exhibited in Theorem 10, allows us to further continue as

$$\begin{aligned}
&= \langle 1 | V \circ (\text{Id}_{\mathcal{K}} \otimes R) (k \otimes \rho) |1\rangle \\
&= \langle 1 | V_k \circ R(\rho) |1\rangle
\end{aligned} \tag{173}$$

which is precisely $\overline{V}_k \circ R(\rho)$. Since this equality holds for all linear operators ρ , we obtain the desired result that the maps are equal. \square

With this lemma in hand, we now proceed to the theorem proper.

Theorem 55. If S is a δ -revocation secure QECCMR, then $\text{TE}(S)$ is $\sqrt{\delta}$ -tamper evident.

Proof. Let $S = (K, E, D, V, R)$ be a QECCMR scheme as given in Definition 40 which has δ -revocation security and let $\text{TE}(S) = (K', E', D')$ be as given in Definition 52.

Let $A' : \mathcal{L}(\mathbb{C}) \rightarrow \mathcal{L}(\mathbb{C} \otimes \mathbb{A})$ be a tamper attack against $\text{TE}(S)$. Then, $A = (R \otimes \text{Id}_{\mathbb{A}}) \circ A'$ is a revocation attack against S . Since S has δ -revocation security, for any two messages $m, m' \in \mathcal{M}$ we have that

$$\mathbb{E}_{k \leftarrow K(\varepsilon)} \frac{1}{2} \left\| (\overline{V}_k \otimes \text{Id}_{\mathbb{A}}) \circ A \circ E_k(m - m') \right\|_1 \leq \delta \quad (174)$$

which, as $\text{Tr}_{\mathbb{M}} \circ \overline{D}'_k = \overline{V}_k \circ R$, implies that

$$\begin{aligned} & \mathbb{E}_{k \leftarrow K(\varepsilon)} \frac{1}{2} \left\| ((\text{Tr}_{\mathbb{M}} \circ \overline{D}'_k) \otimes \text{Id}_{\mathbb{A}}) \circ A' \circ E_k(m - m') \right\|_1 \\ &= \mathbb{E}_{k \leftarrow K(\varepsilon)} \frac{1}{2} \left\| (\overline{V}_k \otimes \text{Id}_{\mathbb{A}}) \circ (R \otimes \text{Id}_{\mathbb{A}}) \circ A' \circ E_k(m - m') \right\|_1 \\ &= \mathbb{E}_{k \leftarrow K(\varepsilon)} \frac{1}{2} \left\| (\overline{V}_k \otimes \text{Id}_{\mathbb{A}}) \circ A \circ E_k(m - m') \right\|_1 \\ &\leq \delta. \end{aligned} \quad (175)$$

Thus, $\text{TE}(S)$ is $\sqrt{\delta}$ -tamper evident by application of Lemma 21. \square

6.4 Revocation Implies Encryption

An interesting and direct corollary to the work we have done so far is that every revocation scheme must be an encryption scheme. This follows from three facts: First, as discussed in Section 4, every tamper-evident scheme is an encryption scheme. Second, as discussed in Section 6.3.2, every revocation scheme can be transformed into a tamper-evident scheme via the mapping $S \mapsto \text{TE}(S)$. And, third, this mapping leaves the key generation and encryption channel unchanged. These observations yield the following.

Corollary 56. Let $S = (K, E, D, V, R)$ be an ϵ -correct QECCMR with δ -revocation security. Then, (K, E, D) is a $\sqrt{19(\sqrt{\delta} + 2\sqrt[8]{\epsilon})}$ -encrypting QECCM.

Proof. By Theorems 53 and 55, we have that $\text{TE}(S) = (K', E', D')$ is a $2\sqrt[4]{\epsilon}$ -correct $\sqrt{\delta}$ -tamper-evident AQECCM. By Theorem 30, which tells us that tamper evidence implies encryption, $\text{TE}(S)$ is $\sqrt{19(\sqrt{\delta} + 2\sqrt[8]{\epsilon})}$ -encrypting. Recall that the property of being encrypting, given in Definition 23, depends only of the key generation and the encoding channels. Moreover, since $\text{TE}(S)$ and (K, E, D) have the same key generation and encoding channels by construction (see Definition 52), it follows that (K, E, D) is a $\sqrt{19(\sqrt{\delta} + 2\sqrt[8]{\epsilon})}$ -encrypting QECCM. \square

7 What Tamper Evidence Is Not

We have so far been concerned with “positive” implications of tamper evidence. We complete this work by changing our perspective and collecting in this section a few shortcomings, or non-implications, of tamper evidence. We have four results in this category:

- In [Section 7.1](#), we show that tamper evidence does not imply uncloneable encryption. In other words, a single ciphertext can be split into two shares, both of which cause the honest decryption procedure to yield the correct message, but neither accepting.
- In [Section 7.2](#), we show that tamper evidence may permit an adversary to split a single ciphertext into two states which are both accepted by the honest decryption procedure, but neither yielding the correct message. In other words, tamper evidence does not imply a unique accepting instance.
- In [Section 7.3.1](#), we show that tamper evidence does not imply authentication.
- In [Section 7.3.2](#), we show that tamper evidence does not imply the encryption of arbitrary quantum states.

In all cases, we obtain optimal separations. We can pick any $\delta > 0$ and instantiate the result for a perfectly correct δ -tamper-evident AQECM where the other security notion is, in some sense, perfectly broken.

The last three results are obtained from the same generic construction using a simple group-based secret sharing scheme described in [Section 7.2](#). Even further, we obtain the last two with precisely the same AQECM scheme described in [Section 7.3](#): a classical one-time pad where only the key is encoded with a tamper-evident scheme.

7.1 Tamper Evidence Does Not Imply Uncloneable Encryption

Uncloneable encryption was first formalized by Broadbent and Lord [[BL20](#)] following ideas and questions initially raised during Gottesman’s work on tamper-evident schemes [[Got03](#)]. We eschew stating a formal definition of uncloneable encryption in this work. It suffices to recall the general principle that a symmetric key encryption scheme is uncloneable if it is infeasible for an initial adversary ignorant of the key used to encrypt a message to split the resulting ciphertext between two subsequent non-communicating adversaries such that both can recover information on the plaintext, even if *they* know the key. In general, the adversaries attempting to recover information on the plaintext are not restricted to using the decryption procedure prescribed by the scheme.

The exact relation between tamper evidence and uncloneable encryption has remained unclear since Gottesman first highlighted both of these notions [[Got03](#)]. In one direction, it is easy to see that uncloneability does not imply tamper evidence as we can equip any uncloneable encryption scheme with a decryption procedure which *always* accepts. Such a scheme cannot offer a non-trivial level of security as a tamper-evident scheme. However, this modification preserves any notion of security as an uncloneable encryption scheme as this security guarantee is independent of the decryption process.

Here, we complete the picture by showing that there is no implication in the other direction either. We do so by explicitly constructing tamper-evident schemes which do not offer any non-trivial security as uncloneable encryption schemes. Specifically, we define a construction taking any tamper-evident scheme S to a new scheme denoted $\text{Double}(S)$ which is the parallel repetition of S , namely $S \otimes S$, encoding the same message *twice* with independent keys.

Note that $\text{Double}(S)$ differs from $S \otimes S$ in two respects: it adds to the encryption map a mechanism to copy classical plaintexts before encoding them and adds a mechanism to select which of the two recovered messages should ultimately be produced after decoding both ciphertexts. This “message selection” mechanism takes the form of an extra qubit added to the ciphertexts that the decryption map will measure to determine which message to output. By showing that these modifications do not negatively change the correctness or security of $\text{Double}(S)$ compared to $S \otimes S$, we obtain that $\text{Double}(S)$ is 2ϵ -correct and 2δ -tamper-evident if S is ϵ -correct and δ -tamper-evident.

Clearly, $\text{Double}(S)$ offers no non-trivial security as an uncloneable encryption scheme. Indeed, by splitting the two encryptions between two different parties, both will be able to recover the plaintext once they learn the key. Even further, due to the way we construct the “message selection” mechanism of the decryption channel, both parties will be able to use the honest decryption map to recover the message, something that is stronger than what is needed to break the uncloneable encryption security guarantee.

We formalize this discussion in what follows.

Definition 57. Let $S = (K, E, D)$ be an AQECM scheme as given in [Definition 13](#) and let $S \otimes S = (K', E', D')$ be the parallel repetition of this scheme with itself, as given in [Definition 25](#). Finally, let $V \in \mathcal{U}(\mathbb{M}, \mathbb{M} \otimes \mathbb{M})$ be the isometry defined by $V = \sum_{m \in \mathcal{M}} |m, m\rangle\langle m|$. Note that V perfectly copies all elements of $m \in \mathcal{M}$, which is to say that $VmV^\dagger = m \otimes m$.

We define $\text{Double}(S) = (K'', E'', D'')$ to be the triplet given by the following channels:

- The key generation channel K'' is identical to the key generation channel of $S \otimes S$, i.e. $K'' = K' = K \otimes K$.
- The encoding channel $E'' : \mathcal{L}(\mathbb{K} \otimes \mathbb{K} \otimes \mathbb{M}) \rightarrow \mathcal{L}(\mathbb{C}^{\{0,1\}} \otimes \mathbb{C} \otimes \mathbb{C})$ is given by

$$\rho \mapsto |0\rangle\langle 0| \otimes E' \left((I_{\mathbb{K} \otimes \mathbb{K}} \otimes V) \rho (I_{\mathbb{K} \otimes \mathbb{K}} \otimes V)^\dagger \right) \quad (176)$$

which is to say that E'' first copies the plaintext, assuming it is in the computational basis, via the isometry V and then simply applies the encoding channel E' from $S \otimes S$, followed by prepending a single qubit in the 0 state.

- Let $\Psi : \mathcal{L}(\mathbb{C}^{\{0,1\}} \otimes \mathbb{M} \otimes \mathbb{M}) \rightarrow \mathcal{L}(\mathbb{M})$ be a channel which measures, in the computational basis, the first qubit it is given and then either discards the second \mathbb{M} register if the measurement outcome is 0 or discards the first \mathbb{M} register if the outcome is 1. In other words, the first qubit indicates which plaintext register is kept. Formally, this is given by the map

$$\begin{aligned} \rho \mapsto & (\text{Id}_{\mathbb{M}} \otimes \text{Tr}_{\mathbb{M}}) ((\langle 0| \otimes I_{\mathbb{M} \otimes \mathbb{M}}) \rho (|0\rangle \otimes I_{\mathbb{M} \otimes \mathbb{M}})) \\ & + (\text{Tr}_{\mathbb{M}} \otimes \text{Id}_{\mathbb{M}}) ((\langle 1| \otimes I_{\mathbb{M} \otimes \mathbb{M}}) \rho (|1\rangle \otimes I_{\mathbb{M} \otimes \mathbb{M}})). \end{aligned} \quad (177)$$

The decoding channel $D'' : \mathcal{L}(\mathbb{K} \otimes \mathbb{K} \otimes \mathbb{C}^{\{0,1\}} \otimes \mathbb{C} \otimes \mathbb{C}) \rightarrow \mathcal{L}(\mathbb{M} \otimes \mathbb{F})$ is then given by

$$D'' = (\Psi \otimes \text{Id}_{\mathbb{F}}) \circ (\text{Id}_{\mathbb{C}^{\{0,1\}}} \otimes D') \circ \left(\text{Swap}_{\mathbb{K}, \mathbb{K}, \mathbb{C}^{\{0,1\}}}^{(2,3,1)} \otimes \text{Id}_{\mathbb{C} \otimes \mathbb{C}} \right) \quad (178)$$

which is to say that D'' begins by applying D' , the decoding map from $S \otimes S$, on all but the first qubit, then checks the first qubit via a computational basis measurement

to determine which message register M to keep and which to discard, all the while keeping the flag qubit produced by D' untouched. The swap channel is merely there to correctly route the key material. Finally, note that $\overline{D''}_{(k_0, k_1)} = \Psi \circ (\text{Id}_{\mathbb{C}^{\{0,1\}}} \otimes \overline{D'}_{(k_0, k_1)})$ for all keys $(k_0, k_1) \in \mathcal{K} \times \mathcal{K}$.

We now prove that the mapping $S \mapsto \text{Double}(S)$ preserves the correctness and security of the scheme, up to the factor of 2 introduced by passing via the $S \otimes S$ scheme.

For correctness, this is essentially trivial. The probability of accepting and correctly recovering both messages, i.e. the $S \otimes S$ correctness criterion, cannot be less than the probability of accepting both messages and correctly recovering the first, which is precisely the $\text{Double}(S)$ correctness criterion.

Theorem 58. If S is an ϵ -correct AQECM scheme, then $\text{Double}(S)$ is 2ϵ -correct.

Proof. This follows essentially immediately from the fact that $S \otimes S$ is 2ϵ -correct, as shown in [Theorem 26](#). We go through the details for completeness.

Let S , $S \otimes S$, and $\text{Double}(S)$ be defined and denoted as in [Definition 57](#). By definition, for every key $(k_0, k_1) \in \mathcal{K} \times \mathcal{K}$ and every message $m \in \mathcal{M}$ we have that

$$E''_{(k_0, k_1)}(m) = |0\rangle\langle 0| \otimes E'_{(k_0, k_1)}(m \otimes m). \quad (179)$$

It then follows that

$$\begin{aligned} & \mathbb{E}_{(k_0, k_1) \leftarrow K''(\epsilon)} \langle m | \overline{D''}_{(k_0, k_1)} \circ E''_{(k_0, k_1)}(m) | m \rangle \\ &= \mathbb{E}_{(k_0, k_1) \leftarrow K'(\epsilon)} \langle m | (\text{Id}_M \otimes \text{Tr}_M) \circ \overline{D'}_{(k_0, k_1)} \circ E'_{k_0, k_1}(m \otimes m) | m \rangle \\ &\geq \mathbb{E}_{(k_0, k_1) \leftarrow K'(\epsilon)} \langle m, m | \overline{D'}_{(k_0, k_1)} \circ E'_{(k_0, k_1)}(m \otimes m) | m, m \rangle \\ &\geq 1 - 2\epsilon \end{aligned} \quad (180)$$

where the first inequality holds as the event of measuring both plaintexts to be m cannot be more likely than the event of measuring the first plaintext to be m and the second inequality follows from the fact that $S \otimes S$ is 2ϵ -correct. Thus, $\text{Double}(S)$ is 2ϵ -correct. \square

For security, we note that the choice to accept or reject the ciphertext is independent of the extra qubit used for the message selection mechanism and that this qubit does not depend on the original message or key. Informally, this means it does not provide any useful information to the adversary. Formally, this means that it can be simulated by the adversary.

Theorem 59. If S is a δ -tamper-evident AQECM, then $\text{Double}(S)$ is 2δ -tamper-evident.

Proof. This follows quickly from the fact that $S \otimes S$ is 2δ -tamper-evident, as shown in [Theorem 26](#). We demonstrate that any attack against $\text{Double}(S)$ implies an attack against $S \otimes S$ with the same performance by showing that an adversary can simulate all differences between these two schemes.

Let S , $S \otimes S$, and $\text{Double}(S)$ be defined and denoted as in [Definition 57](#). Next, let $A'' : \mathcal{L}(\mathbb{C}^{\{0,1\}} \otimes \mathbb{C} \otimes \mathbb{C}) \rightarrow \mathcal{L}(\mathbb{C}^{\{0,1\}} \otimes \mathbb{C} \otimes \mathbb{C} \otimes \mathbb{A})$ be a tamper-attack against $\text{Double}(S)$. Consider now the tamper attack $A' : \mathcal{L}(\mathbb{C} \otimes \mathbb{C}) \rightarrow \mathcal{L}(\mathbb{C} \otimes \mathbb{C} \otimes \mathbb{A})$ against $S \otimes S$ given by

$$\rho \mapsto (\text{Tr}_{\mathbb{C}^{\{0,1\}}} \otimes \text{Id}_{\mathbb{C} \otimes \mathbb{C} \otimes \mathbb{A}}) \circ A'' (|0\rangle\langle 0| \otimes \rho) \quad (181)$$

In essence, A' simulates the attack A'' by first providing it with the extra qubit it expects, and then removing it before returning a ciphertext to the decoding map D' of $S' = S \otimes S$. So, for every message $m \in \mathcal{M}$ and key $(k_0, k_1) \in \mathcal{K} \times \mathcal{K}$, we have by definition that

$$A' \circ E'_{(k_0, k_1)}(m \otimes m) = (\text{Tr}_{\mathbb{C}^{\{0,1\}}} \otimes \text{Id}_{\mathbb{C} \otimes \mathbb{C} \otimes \mathbb{A}}) \circ A'' \circ E''_{(k_0, k_1)}(m). \quad (182)$$

Next, we claim that

$$\text{Tr}_{\mathbb{M}} \circ \overline{D''}_{(k_0, k_1)} = \text{Tr}_{\mathbb{M} \otimes \mathbb{M}} \circ \overline{D'}_{(k_0, k_1)} \circ (\text{Tr}_{\mathbb{C}^{\{0,1\}}} \otimes \text{Id}_{\mathbb{C} \otimes \mathbb{C}}). \quad (183)$$

Intuitively, this is simply stating that discarding the single plaintext ultimately produced by $\overline{D''}_{(k_0, k_1)}$ is equivalent to discarding both plaintexts produced by $\overline{D'}_{(k_0, k_1)}$, ignoring for the moment the extra qubit in the ciphertext. Formally, the trace-preserving property of channels implies that $\text{Tr}_{\mathbb{M}} \circ \Psi = \text{Tr}_{\mathbb{C}^{\{0,1\}} \otimes \mathbb{M} \otimes \mathbb{M}} = \text{Tr}_{\mathbb{C}^{\{0,1\}}} \otimes \text{Tr}_{\mathbb{M} \otimes \mathbb{M}}$. We can then write

$$\begin{aligned} \text{Tr}_{\mathbb{M}} \circ \overline{D''}_{(k_0, k_1)} &= \text{Tr}_{\mathbb{M}} \circ \Psi \circ (\text{Id}_{\mathbb{C}^{\{0,1\}}} \otimes \overline{D'}_{(k_0, k_1)}) \\ &= \text{Tr}_{\mathbb{C}^{\{0,1\}} \otimes \mathbb{M} \otimes \mathbb{M}} (\text{Id}_{\mathbb{C}^{\{0,1\}}} \otimes \overline{D'}_{(k_0, k_1)}) \\ &= \text{Tr}_{\mathbb{C}^{\{0,1\}}} \otimes (\text{Tr}_{\mathbb{M} \otimes \mathbb{M}} \circ \overline{D'}_{(k_0, k_1)}) \\ &= (\text{Tr}_{\mathbb{M} \otimes \mathbb{M}} \circ \overline{D'}_{(k_0, k_1)}) \circ (\text{Tr}_{\mathbb{C}^{\{0,1\}}} \otimes \text{Id}_{\mathbb{C} \otimes \mathbb{C}}) \end{aligned} \quad (184)$$

which is the desired claim.

This, and a final remainder that $K'' = K'$, allows us to write that for any two messages $m, m' \in \mathcal{M}$ it holds that

$$\begin{aligned} &\Pr_{(k_0, k_1) \leftarrow K''(\varepsilon)} \left[\frac{1}{2} \left\| ((\text{Tr}_{\mathbb{M}} \circ \overline{D''}_{(k_0, k_1)}) \otimes \text{Id}_{\mathbb{A}}) \circ A'' \circ E''_{(k_0, k_1)}(m - m') \right\|_1 \leq 2\delta \right] \\ &= \Pr_{(k_0, k_1) \leftarrow K'(\varepsilon)} \left[\frac{1}{2} \left\| ((\text{Tr}_{\mathbb{M} \otimes \mathbb{M}} \circ \overline{D'}_{(k_0, k_1)}) \otimes \text{Id}_{\mathbb{A}}) \circ A' \circ E'_{(k_0, k_1)}(m \otimes m - m' \otimes m') \right\|_1 \leq 2\delta \right] \\ &\geq 1 - 2\delta \end{aligned} \quad (185)$$

where the last inequality follows from the fact that $S \otimes S$ is 2δ -tamper evident. Thus, the scheme $\text{Double}(S)$ is also 2δ -tamper evident. \square

As mentioned, the end result of this construction is that it yields an optimal separation between tamper-evident schemes and uncloneable encryption schemes. This is the content of the next theorem.

Theorem 60. For any strictly positive $\delta \in \mathbb{R}^+$ and any alphabet \mathcal{M} , there exists a perfectly correct δ -tamper-evident scheme $S' = (K', E', D')$ with messages \mathcal{M} and ciphertext space \mathbb{C}' as well as a channel $\tilde{A} : \mathcal{L}(\mathbb{C}' \otimes \mathbb{C}') \rightarrow \mathcal{L}(\mathbb{C}' \otimes \mathbb{C}')$ such that for any message $m \in \mathcal{M}$ and any key k' with $\langle k' | K'(\varepsilon) | k' \rangle > 0$, we have that

$$\langle m, m | (\text{Id}_{\mathbb{M}} \otimes \text{Tr}_{\mathbb{F}} \otimes \text{Id}_{\mathbb{M}} \otimes \text{Tr}_{\mathbb{F}}) \circ (D'_{k'} \circ D'_{k'}) \circ \tilde{A} \circ E'_k(m) | m, m \rangle = 1. \quad (186)$$

Proof. By [Theorem 22](#), there exists a perfectly correct $\frac{\delta}{2}$ -tamper-evident AQECM scheme S with messages \mathcal{M} . Then, $S' = \text{Double}(S)$ is a perfectly correct δ -tamper-evident scheme. It then suffices to consider the channel \tilde{A} given by

$$\rho \mapsto \text{Swap}_{\mathbb{C}^{\{0,1\}}, \mathbb{C}^{\{0,1\}}, \mathbb{C}, \mathbb{C}, \mathbb{C}, \mathbb{C}}^{(1,4,3,5,2,6)} \left(|0\rangle\langle 0| \otimes |1\rangle\langle 1| \otimes \frac{\text{Id}_{\mathbb{C}}}{\dim \mathbb{C}} \otimes \frac{\text{Id}_{\mathbb{C}}}{\dim \mathbb{C}} \otimes (\text{Tr}_{\mathbb{C}^{\{0,1\}}} \otimes \text{Id}_{\mathbb{C} \otimes \mathbb{C}}) (\rho) \right) \quad (187)$$

so that for any key $k' = (k_0, k_1)$ which has a non-zero probability of being produced by K' and any message m we have

$$\tilde{A} \circ E'_{(k_0, k_1)}(m) = \left(|0\rangle\langle 0| \otimes E_{k_0}(m) \otimes \frac{\text{Id}_{\mathbb{C}}}{\dim \mathbb{C}} \right) \otimes \left(|1\rangle\langle 1| \otimes \frac{\text{Id}_{\mathbb{C}}}{\dim \mathbb{C}} \otimes E_{k_1}(m) \right). \quad (188)$$

Both of these are valid ciphertexts for the scheme $\text{Double}(S)$ and it is clear that the decryption map $D'_{(k_0, k_1)}$ of $\text{Double}(S)$ will recover the correct plaintext m in both cases due to how the plaintext selection qubit is fixed and the perfect correctness of the scheme S . \square

7.2 Tamper Evidence With A Simple Secret Sharing Scheme

We describe in this section a method to construct a tamper-evident scheme by combining two tamper-evident schemes with a secret sharing scheme (e.g.: [\[KL15, Sec. 13.3\]](#)). This construction will be useful to obtain various separations.

We conjecture that our construction works with *any* information theoretic 2-out-of-2, or even any k -out-of- n secret sharing scheme, but we restrict ourselves to considering the following simple group-based secret sharing scheme similar to the one-time pad. Consider an alphabet \mathcal{M} equipped with a binary operation $*$: $\mathcal{M} \times \mathcal{M} \rightarrow \mathcal{M}$ such that $(\mathcal{M}, *)$ forms a group. The secret sharing scheme we use maps any element $m \in \mathcal{M}$ to the couple $(p, p * m)$ for a uniformly random $p \in \mathcal{M}$. Clearly, neither p nor $p * m$, independently, depends on m when p is sampled uniformly at random. This holds as $p \mapsto p * m$ is a permutation for all $m \in \mathcal{M}$. Hence, neither pieces of information alone is sufficient to obtain any information on m . But, knowledge of both p and $p * m$ is clearly sufficient to recover m .

We combine this secret sharing scheme with any two AQECM schemes $S = (K, E, D)$ and $S' = (K', E', D')$ which share the same messages \mathcal{M} to obtain a new AQECM we will denote $S * S'$. On input of a message m and a pair of keys $(k, k') \in \mathcal{K} \times \mathcal{K}'$, the encryption procedure of this new scheme will sample a uniformly random $p \in \mathcal{M}$ and output $E_k(p) \otimes E_{k'}(p * m)$. The decryption procedure of $S * S'$ will proceed as expected: both ciphertexts will be decrypted using the decryption maps D and D' , respectively, and the appropriate group action will be applied to recover the message m . However, the decryption map of $S * S'$ will reject if and only if *both* ciphertexts were rejected by D . Otherwise, i.e. if at least one of D or D' accepts, the decryption map of $S * S'$ will accept.

Assume that S and S' exhibit sufficiently good correctness and security as tamper-evident schemes. Correctness of $S * S'$ follows naturally from the correctness of S and S' . The security of $S * S'$ as a tamper-evident scheme essentially follows from the fact that if no tampering is detected on at least one of the two ciphertexts produced by this scheme, then an eavesdropper is highly unlikely to have learned information on both shares of the secret sharing scheme and hence is unlikely to have learned any information on the message.

We formalize this discussion in the following. In particular, we will require that the group operation be computed coherently. This will be a useful property later.

Definition 61. Let $S = (K, E, D)$ and $S' = (K', E', D')$ be two AQECM schemes as given in Definition 13 which share the same message space \mathcal{M} . Let this message space be equipped with a group operation denoted $*$ and let $U_* \in \mathcal{U}(\mathbb{M} \otimes \mathbb{M})$ be the unitary operator which coherently computes this operation, which is to say that $U(|a\rangle \otimes |b\rangle) = |a\rangle \otimes |a * b\rangle$ for all $a, b \in \mathcal{M}$.²⁵ We define the AQECM scheme $S * S' = (K^*, E^*, D^*)$ as follows:

- The key generation channel $K^* : \mathbb{C} \rightarrow \mathcal{L}(\mathbb{K} \otimes \mathbb{K}')$ is simply the parallel application of the key generation channels of S and S' , i.e. $K^* = K \otimes K'$.
- The encryption channel $E^* : \mathcal{L}(\mathbb{K} \otimes \mathbb{K}' \otimes \mathbb{M}) \rightarrow \mathcal{L}(\mathbb{C} \otimes \mathbb{C}')$ is given by

$$\rho \mapsto \mathbb{E}_{p \leftarrow \mathcal{M}} (E \otimes E') \circ \text{Swap}_{\mathbb{K}, \mathbb{K}', \mathbb{M}, \mathbb{M}}^{(1,3,2,4)} \left((I_{\mathbb{K} \otimes \mathbb{K}'} \otimes U_*) (p \otimes \rho) (I_{\mathbb{K} \otimes \mathbb{K}'} \otimes U_*)^\dagger \right). \quad (189)$$

In other words, E^* samples uniformly at random an element $p \in \mathcal{M}$, coherently computes the result of the group action between the supplied message and p and encrypts the resulting state on the message spaces with $E \otimes E'$ after having properly routed the keys. For a state of the expected form $\rho = k \otimes k' \otimes m$, the result of this channel is

$$E_{(k,k')}^*(m) = \mathbb{E}_{p \leftarrow \mathcal{M}} E_k(p) \otimes E_{k'}'(p * m). \quad (190)$$

- The decryption channel $D^* : \mathcal{L}(\mathbb{K} \otimes \mathbb{K}' \otimes \mathbb{C} \otimes \mathbb{C}') \rightarrow \mathcal{L}(\mathbb{M} \otimes \mathbb{F})$ is given by

$$\rho \mapsto W \circ (D \otimes D') \circ \text{Swap}_{\mathbb{K}, \mathbb{K}', \mathbb{C}, \mathbb{C}'}^{(1,3,2,4)}(\rho) \quad (191)$$

where $W : \mathcal{L}(\mathbb{M} \otimes \mathbb{F} \otimes \mathbb{M} \otimes \mathbb{F}) \rightarrow \mathcal{L}(\mathbb{M} \otimes \mathbb{F})$ is a channel which (1) measures both flag qubits produced by D and D' and outputs the logical “or” of the result, (2) coherently undoes the group operation on the message spaces, and (3) discards the final unnecessary message space supposed to hold the p element sampled by the encryption channel. Formally, this is given by

$$\rho \mapsto (\text{Tr}_{\mathbb{M}} \otimes \text{Id}_{\mathbb{M} \otimes \mathbb{F}}) \left(\sum_{b, b' \in \{0,1\}} \left(U_*^\dagger \otimes |b \vee b'\rangle\langle b, b'| \right) \text{Swap}_{\mathbb{M}, \mathbb{F}, \mathbb{M}, \mathbb{F}}^{(1,3,2,4)}(\rho) (U_* \otimes |b, b'\rangle\langle b \vee b'|) \right). \quad (192)$$

The following theorem states that if S and S' are ϵ -correct and ϵ' -correct, then $S * S'$ is $(\epsilon + \epsilon')$ -correct. This follows from the fact that the probability that the decryption procedure of $S * S'$ both produces the correct message and accepts is at least the probability that both instances of the decryption procedure from S accept and produce the correct messages. As the keys are independently sampled, this is at least $(1 - \epsilon)(1 - \epsilon') \geq 1 - (\epsilon + \epsilon')$. Note that this is identical to the correctness of $S \otimes S'$. In particular, we are disregarding the possibility that only one decryption procedure accepts, or that these decryption maps both output wrong messages which, by coincidence, still lead to the correct message being recovered after application of the group operation.

²⁵Such a group operation can be found for any alphabet \mathcal{M} by considering any bijection $\phi : \mathcal{M} \rightarrow \mathbb{Z}/|\mathcal{M}|\mathbb{Z}$, where $\mathbb{Z}/|\mathcal{M}|\mathbb{Z}$ is the additive group of integers modulo $|\mathcal{M}|$. Simply define $m * m' = \phi^{-1}(\phi(m) + \phi(m'))$.

Theorem 62. Let S and S' be ϵ - and ϵ' -correct AQECMs, respectively, with the same message space \mathcal{M} which admits a group operation denoted $*$. Then, $S * S'$ is $(\epsilon + \epsilon')$ -correct.

Proof. For all keys $(k, k') \in \mathcal{K} \times \mathcal{K}'$ and all messages $m \in \mathcal{M}$ we have by definition that

$$\begin{aligned} \langle m | \overline{D^*}_{(k,k')} \circ E^*_{(k,k')}(m) | m \rangle &= \mathbb{E}_{p \leftarrow \mathcal{M}} \langle m | \overline{D^*}_{(k,k')} (E_k(p) \otimes E_{k'}(p * m)) | m \rangle \\ &\geq \mathbb{E}_{p \leftarrow \mathcal{M}} \langle p, p * m | \overline{D}_k \circ E_k(p) \otimes \overline{D}'_{k'} \circ E'_{k'}(p * m) | p, p * m \rangle \\ &= \mathbb{E}_{p \leftarrow \mathcal{M}} \langle p | \overline{D}_k \circ E_k(p) | p \rangle \cdot \langle p * m | \overline{D}'_{k'} \circ E'_{k'}(p * m) | p * m \rangle \end{aligned} \quad (193)$$

Now, recalling that $K^* = K \otimes K'$ so that both elements of the key pair are generated independently, we have that

$$\begin{aligned} &\mathbb{E}_{(k,k') \leftarrow K^*(\epsilon)} \langle m | \overline{D^*}_{(k_0,k_1)} \circ E^*_{(k_0,k_1)}(m) | m \rangle \\ &\geq \mathbb{E}_{p \leftarrow \mathcal{M}} \left(\mathbb{E}_{k \leftarrow K(\epsilon)} \langle p | \overline{D}_k \circ E_k(p) | p \rangle \right) \left(\mathbb{E}_{k' \leftarrow K'(\epsilon)} \langle p * m | \overline{D}'_{k'} \circ E'_{k'}(p * m) | p * m \rangle \right) \\ &\geq \mathbb{E}_{p \leftarrow \mathcal{M}} (1 - \epsilon)(1 - \epsilon') \\ &\geq 1 - (\epsilon + \epsilon') \end{aligned} \quad (194)$$

which is the desired result. \square

We now move on the proving the security of $S * S'$. We begin with a technical lemma providing us with a useful decomposition of the map $\text{Tr}_M \circ \overline{D^*}_{(k,k')}$ obtained by application of the inclusion-exclusion principal. Note that this channel computes the probability that at least one of the two underlying ciphertexts is accepted. This is equal to the probability that the first is accepted, plus the probability that the second is accepted, minus the probability that both were accepted.

Lemma 63. In the notation of [Definition 61](#), we have for every $(k, k') \in \mathcal{K} \times \mathcal{K}'$ that

$$\text{Tr}_M \circ \overline{D^*}_{(k,k')} = (\text{Tr}_M \circ \overline{D}_k) \otimes \text{Tr}_C + \text{Tr}_C \otimes (\text{Tr}_M \circ \overline{D}'_{k'}) - (\text{Tr}_M \circ \overline{D}_k) \otimes (\text{Tr}_M \circ \overline{D}'_{k'}). \quad (195)$$

Proof. By definition, for every key pair $(k, k') \in \mathcal{K} \times \mathcal{K}'$ we have that $\overline{D^*}_{(k,k')}(\rho)$ is given by

$$(\text{Tr}_M \otimes \text{Id}_M) \left(\sum_{\substack{b,b' \in \{0,1\} \\ (b,b') \neq (0,0)}} \left(U_*^\dagger \otimes \langle b, b' | \right) \text{Swap}_{M,F,M,F}^{(1,3,2,4)} \circ (D_k \otimes D'_{k'}) (\rho) (U_* \otimes |b, b'\rangle) \right) \quad (196)$$

It follows that $\text{Tr}_M \circ \overline{D^*}_{(k,k')}(\rho)$ is given by

$$\text{Tr}_{M \otimes M} \left(\sum_{\substack{b,b' \in \{0,1\} \\ (b,b') \neq (0,0)}} \left(U_*^\dagger \otimes \langle b, b' | \right) \text{Swap}_{M,F,M,F}^{(1,3,2,4)} \circ (D_k \otimes D'_{k'}) (\rho) (U_* \otimes |b, b'\rangle) \right). \quad (197)$$

Tracing out the message spaces after undoing the group operation via conjugation by U_*^\dagger is equivalent to tracing them out before this conjugation. We can even take this trace prior to the Swap operation. Hence, the previous expression is equivalent to

$$\sum_{\substack{b,b' \in \{0,1\} \\ (b,b') \neq (0,0)}} \langle b, b' | (((\text{Tr}_M \otimes \text{Id}_F) \circ D_k) \otimes ((\text{Tr}_M \otimes \text{Id}_F) \circ D'_{k'})) (\rho) | b, b' \rangle \quad (198)$$

which is, in turn, equivalent to

$$((\text{Tr}_M \circ \overline{D}_k) \otimes \text{Tr}_{C'} + \text{Tr}_C \otimes (\text{Tr}_M \circ \overline{D}'_{k'})) - (\text{Tr}_M \circ \overline{D}_k) \otimes (\text{Tr}_M \circ \overline{D}'_{k'}) (\rho) \quad (199)$$

where the first summand counts the cases of $(b_0, b_1) \in \{(1, 0), (1, 1)\}$, the second the cases of $(b_0, b_1) \in \{(0, 1), (1, 1)\}$, and the third accounts for the fact that the case of $(b_0, b_1) = (1, 1)$ would otherwise be double counted. Note that the Tr_C term arise as a result of the fact that $\sum_{b \in \{0,1\}} \langle b | (\text{Tr}_M \otimes \text{Id}_F) D_k(\rho) | b \rangle = (\text{Tr}_M \otimes \text{Tr}_F) \circ D_k(\rho) = \text{Tr}_C(\rho)$ where the first equality is obtained by a characterization of the trace and the second by the fact that D_k is trace preserving. The $\text{Tr}_{C'}$ arises similarly. \square

With the previous lemma in hand, we can now prove the security of $S * S'$.

Theorem 64. Let S and S' be δ - and δ' -tamper-evident AQECMs, respectively, with the same message space \mathcal{M} which admits a group operation denoted $*$. Then, the AQECM scheme $S * S'$ is $2\sqrt{\delta + \delta'}$ -tamper evident.

Proof. Fix two messages $m, \tilde{m} \in \mathcal{M}$ and a tamper attack $A^* : \mathcal{L}(C \otimes C') \rightarrow \mathcal{L}(C \otimes C' \otimes A^*)$ against the AQECM scheme $S * S' = (K^*, E^*, D^*)$. For any two elements $p, m \in \mathcal{M}$ and any key $(k, k') \in \mathcal{K} \times \mathcal{K}' = \mathcal{K}^*$, we define the states

$$\rho_{k,k'}^{p,m} = A^* (E_k(p) \otimes E'_{k'}(p * m)) \quad (200)$$

and

$$\rho_{k,k'}^m = A^* \circ E^*_{(k,k')}(m). \quad (201)$$

Note that $\rho_{k,k'}^{p,m}$ is the state after the adversaries attack — but before the application of the decryption map — when the message m is encrypted with the key (k, k') and the secret sharing scheme picked p as the additional element. Further note that $\rho_{k,k'}^m = \mathbb{E}_{p \leftarrow \mathcal{M}} \rho_{k,k'}^{p,m}$ is the same state, but averaged over all choices of p .

Recall that [Lemma 21](#) essentially restates the property of being tamper evident from a concentration inequality on

$$\frac{1}{2} \left\| ((\text{Tr}_M \circ \overline{D}^*_{(k,k')}) \otimes \text{Id}_{A^*}) (\rho_{k,k'}^m - \rho_{k,k'}^{\tilde{m}}) \right\|_1 \quad (202)$$

over the sampling of the key (k, k') to an expectation of this trace distance over the same sampling. This is done via Markov's inequality ([Theorem 1](#)). Our goal for the remainder of the proof will be to give an upper bound for the expected value of this quantity over sampling of the key (k, k') . We note that working with the expectations will simplify our accounting of the random sampling of the p value by the encryption channel E^* .

Using the result and notation of [Lemma 63](#), linearity, and the fact that norms are subadditive, for any key $(k, k') \in \mathcal{K}^*$ and any two messages $m, \tilde{m} \in \mathcal{M}$, we have that

$$\begin{aligned}
& \mathbb{E}_{(k, k') \leftarrow K^*(\varepsilon)} \frac{1}{2} \left\| \left((\text{Tr}_M \circ \overline{D}^*_{(k, k')}) \otimes \text{Id}_{A^*} \right) (\rho_{k, k'}^m - \rho_{k, k'}^{\tilde{m}}) \right\|_1 \\
& \leq \mathbb{E}_{(k, k') \leftarrow K^*(\varepsilon)} \mathbb{E}_{p \leftarrow \mathcal{M}} \frac{1}{2} \left\| \left((\text{Tr}_M \circ \overline{D}^*_{(k, k')}) \otimes \text{Id}_{A^*} \right) (\rho_{k, k'}^{p, m} - \rho_{k, k'}^{p, \tilde{m}}) \right\|_1 \\
& \leq \mathbb{E}_{(k, k') \leftarrow K^*(\varepsilon)} \mathbb{E}_{p \leftarrow \mathcal{M}} \frac{1}{2} \left\| \left((\text{Tr}_M \circ \overline{D}_k) \otimes \text{Tr}_{C'} \otimes \text{Id}_A \right) (\rho_{k, k'}^{p, m} - \rho_{k, k'}^{p, \tilde{m}}) \right\|_1 \\
& \quad + \mathbb{E}_{(k, k') \leftarrow K^*(\varepsilon)} \mathbb{E}_{p \leftarrow \mathcal{M}} \frac{1}{2} \left\| \left(\text{Tr}_C \otimes (\text{Tr}_M \circ \overline{D}'_{k'}) \otimes \text{Id}_A \right) (\rho_{k, k'}^{p, m} - \rho_{k, k'}^{p, \tilde{m}}) \right\|_1 \\
& \quad + \mathbb{E}_{(k, k') \leftarrow K^*(\varepsilon)} \mathbb{E}_{p \leftarrow \mathcal{M}} \frac{1}{2} \left\| \left((\text{Tr}_M \circ \overline{D}_k) \otimes (\text{Tr}_M \circ \overline{D}'_{k'}) \otimes \text{Id}_A \right) (\rho_{k, k'}^{p, m} - \rho_{k, k'}^{p, \tilde{m}}) \right\|_1.
\end{aligned} \tag{203}$$

Looking at the last of these inequalities, we will give an upperbound on the first two summands by using the fact that S and S' are δ - and δ' -tamper-evident, respectively, and we will upperbound the third summand by using the fact that $S \otimes S'$ is $(\delta + \delta')$ -tamper-evident by [Theorem 27](#).

We begin with the third summand. Let $S'' = S \otimes S' = (K'', E'', D'')$ and note the following facts. First, the channel A^* is also tamper-attack against S'' , second we have that $(\text{Tr}_M \circ \overline{D}_k) \otimes (\text{Tr}_M \circ \overline{D}'_{k'}) = \text{Tr}_{M \otimes M} \circ \overline{D}''_{(k, k')}$, and third by construction we have that $K^* = K''$. These, with the fact that S'' is $(\delta + \delta')$ -tamper evident, imply via [Lemma 21](#) that

$$\mathbb{E}_{(k, k') \leftarrow K^*(\varepsilon)} \frac{1}{2} \left\| \left((\text{Tr}_M \circ \overline{D}_k) \otimes (\text{Tr}_M \circ \overline{D}'_{k'}) \otimes \text{Id}_{A^*} \right) (\rho_{k, k'}^{p, m} - \rho_{k, k'}^{p, \tilde{m}}) \right\|_1 \leq 2(\delta + \delta') - (\delta + \delta')^2 \tag{204}$$

for all $p \in \mathcal{M}$. As this inequality holds for all $p \in \mathcal{M}$, we can also bound the expectation over the sampling of p :

$$\mathbb{E}_{(k, k') \leftarrow K^*(\varepsilon)} \mathbb{E}_{p \leftarrow \mathcal{M}} \frac{1}{2} \left\| \left((\text{Tr}_M \circ \overline{D}_k) \otimes (\text{Tr}_M \circ \overline{D}'_{k'}) \otimes \text{Id}_{A^*} \right) (\rho_{k, k'}^{p, m} - \rho_{k, k'}^{p, \tilde{m}}) \right\|_1 \leq 2(\delta + \delta') - (\delta + \delta')^2. \tag{205}$$

We now move on to the first two summands. We will only explicitly treat the second as the bound for first second is obtained completely analogously. For every $p \in \mathcal{M}$ and $k \in \mathcal{K}$, let $A'_{k, p} : \mathcal{L}(C') \rightarrow \mathcal{L}(C' \otimes A^*)$ be defined by

$$\rho \mapsto (\text{Tr}_C \otimes \text{Id}_{C' \otimes A^*}) \circ A^*(E_k(p) \otimes \rho). \tag{206}$$

Note that $A'_{k, p}$ is a tamper-attack against the underlying AQECM scheme S' which is assumed to be δ' -tamper-evident. Thus, for every $m, \tilde{m} \in \mathcal{M}$ [Lemma 21](#) implies that

$$\mathbb{E}_{k' \leftarrow K'(\varepsilon)} \frac{1}{2} \left\| \left((\text{Tr}_M \circ \overline{D}'_{k'}) \otimes \text{Id}_{A^*} \right) \circ A'_{k, p} \circ E'_{k'}((m * p) - (\tilde{m} * p)) \right\|_1 \leq 2\delta' - \delta'^2. \tag{207}$$

On the other hand, by definition of $A'_{k,p}$, we have that

$$\begin{aligned}
& ((\text{Tr}_M \circ \overline{D}'_{k'}) \otimes \text{Id}_{A^*}) \circ A'_{k,p} (E'_{k'}((p * m) - (p * \tilde{m}))) \\
&= ((\text{Tr}_M \circ \overline{D}'_{k'}) \otimes \text{Id}_{A^*}) \circ (\text{Tr}_C \otimes \text{Id}_{C' \otimes A^*}) \circ A^* (E_k(p) \otimes E'_{k'}(p * m) - E_k(p) \otimes E'_{k'}(p * \tilde{m})) \\
&= (\text{Tr}_C \otimes (\text{Tr}_M \circ \overline{D}'_{k'}) \otimes \text{Id}_{A^*}) \left(\rho_{k,k'}^{m,p} - \rho_{k,k'}^{\tilde{m},p} \right).
\end{aligned} \tag{208}$$

Thus,

$$\mathbb{E}_{k' \leftarrow K'(\varepsilon)} \frac{1}{2} \left\| (\text{Tr}_C \otimes (\text{Tr}_M \circ \overline{D}'_{k'}) \otimes \text{Id}_{A^*}) \left(\rho_{k,k'}^{m,p} - \rho_{k,k'}^{\tilde{m},p} \right) \right\|_1 \leq 2\delta' - \delta'^2. \tag{209}$$

As this holds for all k and all p , we can also bound the expectation over the sampling of both these values:

$$\mathbb{E}_{(k,k') \leftarrow K^*(\varepsilon)} \mathbb{E}_{p \leftarrow \mathcal{M}} \frac{1}{2} \left\| (\text{Tr}_C \otimes (\text{Tr}_M \circ \overline{D}'_k) \otimes \text{Id}_{A^*}) \left(\rho_{k,k'}^{m,p} - \rho_{k,k'}^{\tilde{m},p} \right) \right\|_1 \leq 2\delta' - \delta'^2. \tag{210}$$

Noting that $\mathbb{E}_{p \leftarrow \mathcal{M}} E_k(p) \otimes E'_{k'}(p * m) = \mathbb{E}_{p \leftarrow \mathcal{M}} E_k(p * m^{-1}) \otimes E'_{k'}(p)$ where m^{-1} is the inverse of m for $*$, a similar exercise for the first summand will yield

$$\mathbb{E}_{(k,k') \leftarrow K^*(\varepsilon)} \mathbb{E}_{p \leftarrow \mathcal{M}} \frac{1}{2} \left\| ((\text{Tr}_M \circ \overline{D}_k) \otimes \text{Tr}_{C'} \otimes \text{Id}_{A^*}) \left(\rho_{k,k'}^{m,p} - \rho_{k,k'}^{\tilde{m},p} \right) \right\|_1 \leq 2\delta - \delta^2. \tag{211}$$

We conclude that

$$\begin{aligned}
\mathbb{E}_{(k,k') \leftarrow K^*(\varepsilon)} \frac{1}{2} \left\| ((\text{Tr}_M \circ \overline{D}^*_{(k,k')}) \otimes \text{Id}_{A^*}) \left(\rho_{k,k'}^m - \rho_{k,k'}^{\tilde{m}} \right) \right\|_1 &\leq 4(\delta + \delta') - (\delta + \delta')^2 - \delta^2 - \delta'^2 \\
&\leq 4(\delta + \delta')
\end{aligned} \tag{212}$$

where, for simplicity, we drop the higher order terms. A final invocation of [Lemma 21](#) with this bound yields that S^* is $2\sqrt{\delta + \delta'}$ -tamper evident. \square

In the following theorem, we precisely state that ciphertexts produced by $S * S'$ can be split into two parts, both of which will be accepted by the honest decryption procedure. We merely sketch the proof as the idea is quite simple: leave one unmodified encoded share of the secret sharing scheme in each part.

Theorem 65. For every $\delta > 0$ and every alphabet \mathcal{M} , there exists a perfectly correct δ -tamper-evident AQECM scheme with messages \mathcal{M} as well as a channel \tilde{A} satisfying

$$\mathbb{E}_{k \leftarrow K(\varepsilon)} \text{Tr} \left[(\overline{D}_k \otimes \overline{D}_k) \circ \tilde{A} \circ E_k(m) \right] = 1 \tag{213}$$

for all messages $m \in \mathcal{M}$.

Proof. By [Theorem 22](#), there exists a perfectly correct $\frac{1}{2}\delta^2$ -tamper-evident AQECM scheme S' with messages \mathcal{M} . Consider now $S = S' * S'$ which is a perfectly correct δ -tamper-evident AQECM with messages \mathcal{M} . It then suffices to take the channel $\tilde{A} : \mathcal{L}(C) \rightarrow \mathcal{L}(C \otimes C)$ defined by

$$\rho \mapsto \text{Swap}_{C,C',C'}^{(1,4,2,3)} \left(\rho \otimes \frac{I_{C'}}{\dim C'} \otimes \frac{I_{C'}}{\dim C'} \right) \tag{214}$$

where C' is the ciphertext space of the underlying AQECM scheme S' . Thus, for any messages m and key $k = (k_0, k_1)$, we have that

$$\begin{aligned}\tilde{A} \circ E_k(m) &= \tilde{A} \left(\mathbb{E}_{p \leftarrow \mathcal{M}} E'_{k_0}(p) \otimes E'_{k_1}(p * m) \right) \\ &= \mathbb{E}_{p \leftarrow \mathcal{M}} \left(E'_{k_0}(p) \otimes \frac{I_{C'}}{\dim C'} \right) \otimes \left(\frac{I_{C'}}{\dim C'} \otimes E'_{k_1}(p * m) \right).\end{aligned}\tag{215}$$

The fact that the underlying scheme S' is perfectly correct implies that both instances of the decryption map in \bar{D}_k will accept with certainty for any $k = (k_0, k_1)$, m and p . \square

7.3 One-Time Pad With a Tamper-Evident Encoded Key

The goal of this subsection is to formally study an AQECM scheme obtained by combining a classical one-time pad with a tamper-evident scheme $S = (K, E, D)$. The idea is to encode a message m with a random one-time pad p and then encrypt p with the tamper-evident scheme and make the resulting state part of the ciphertext. For a key k and a message m taken from an alphabet \mathcal{M} equipped with a group action $*$, the ciphertexts produced by this scheme are of the form

$$\mathbb{E}_{p \leftarrow \mathcal{M}} E_k(p) \otimes (p * m).\tag{216}$$

Decryption proceeds as expected. With the key k , recover p from the first component using the decryption map D_k from the AQECM scheme S , after which m can be recovered from the second component $p * m$. Accept if and only if D_k accepted.

As we will see, such a scheme will be a useful example to demonstrate that tamper evidence does *not* imply certain properties.

Note that this scheme appears quite similar to the ones constructed in [Section 7.2](#). In fact, one could describe this scheme as simply $S * T$ where T is a trivial AQECM scheme on the same message space \mathcal{M} . We formally give such a trivial scheme in the next definition.

Definition 66. Let \mathcal{M} be an alphabet. The *always rejecting trivial AQECM scheme for \mathcal{M}* , denoted $\text{Triv}^{\mathcal{M},0}$, is an AQECM scheme with messages \mathcal{M} , a single key $\mathcal{K} = \{\varepsilon\}$, ciphertext space $C = M$, and defined by the following three channels:

- The key generation channel $K^{\mathcal{M},0}$ is the identity on $\mathbb{C}^{\{\varepsilon\}}$, which is isomorphic to \mathbb{C} .
- The encryption channel $E^{\mathcal{M},0}$ is the identity on $\mathcal{L}(M) = \mathcal{L}(C)$.
- The decryption channel $D^{\mathcal{M},0} : \mathcal{L}(C) \rightarrow \mathcal{L}(M \otimes F)$ is defined by $\rho \mapsto \rho \otimes |0\rangle\langle 0|$.

We neglect the key space in the domains of $E^{\mathcal{M},0}$ and $D^{\mathcal{M},0}$ as $\mathbb{C} \otimes M = M = C = \mathbb{C} \otimes C$ and will omit the ε subscript for simplicity when discussing the keyed version of these channels.

By construction, $S^* = S * \text{Triv}^{\mathcal{M},0}$ is precisely the scheme we have described and that we wish to study here.

Note that by always rejecting, the AQECM scheme $\text{Triv}^{\mathcal{M},0}$ is 0-tamper-evident. However, this comes at the cost of not achieving any non-trivial level of correctness as correctness requires accepting certain ciphertexts.

Lemma 67. For any alphabet \mathcal{M} , the scheme $\text{Triv}^{\mathcal{M},0}$ is 0-tamper evident.

Proof. As $D^{\mathcal{M},0}$ always rejects, the map $\overline{D^{\mathcal{M},0}} : \mathcal{L}(\mathbb{C}) \rightarrow \mathcal{L}(\mathbb{M})$ takes any linear operator to the zero operator $\mathbf{0}_{\mathbb{M}} \in \mathcal{L}(\mathbb{M})$. Moreover, for any other linear operator $L \in \mathcal{L}(\mathbb{A})$, it holds that $\mathbf{0}_{\mathbb{M}} \otimes L = \mathbf{0}_{\mathbb{M}} \otimes \mathbf{0}_{\mathbb{A}}$. Hence, for any tamper attack A and any messages m and \tilde{m} ,

$$\frac{1}{2} \left\| \left(\left(\text{Tr}_{\mathbb{M}} \circ \overline{D^{\mathcal{M},0}} \right) \otimes \text{Id}_{\mathbb{A}} \right) \circ A \circ E(m - \tilde{m}) \right\|_1 = \frac{1}{2} \|\mathbf{0}_{\mathbb{A}} - \mathbf{0}_{\mathbb{A}}\|_1 = 0 \quad (217)$$

which yields the desired result. \square

By [Theorem 64](#) and the previous lemma, if S is δ -tamper evident, then S^* is $2\sqrt{\delta}$ -tamper evident.²⁶ However, since $\text{Triv}^{\mathcal{M},0}$ is 1-correct, we cannot use [Theorem 62](#) to show that the scheme S^* exhibits non-trivial correctness. Instead, we will directly prove that S^* is as correct as S . This is the content of the following theorem.

Theorem 68. Let $S = (K, E, D)$ be an ϵ -correct δ -tamper-evident scheme with messages \mathcal{M} which admit a group operation denoted $*$. Then, $S * \text{Triv}^{\mathcal{M},0} = (K^*, E^*, D^*)$ is $2\sqrt{\delta}$ -tamper-evident and ϵ -correct.

Proof. That $S * \text{Triv}^{\mathcal{M},0}$ is $2\sqrt{\delta}$ -tamper evident follows immediately from [Lemma 67](#) and [Theorem 64](#). The generic correctness result of [Theorem 62](#) is not sufficient in this case as it only yields $(1 + \epsilon)$ -correctness. However, direct computation yields

$$\begin{aligned} \mathbb{E}_{k \leftarrow K^*(\epsilon)} \langle m | \overline{D_k^*} \circ E_k^*(m) | m \rangle &= \mathbb{E}_{k \leftarrow K(\epsilon)} \mathbb{E}_{p \leftarrow \mathcal{M}} \langle m | \overline{D_k^*}(E_k(p) \otimes (p * m)) | m \rangle \\ &= \mathbb{E}_{k \leftarrow K(\epsilon)} \mathbb{E}_{p \leftarrow \mathcal{M}} \langle p | \overline{D_k} \circ E_k(p) | p \rangle \\ &\geq \mathbb{E}_{p \leftarrow \mathcal{M}} (1 - \epsilon) \\ &\geq 1 - \epsilon \end{aligned} \quad (218)$$

where the first equality follows by definition of K^* , E^* , and $\text{Triv}^{\mathcal{M},0}$, while the second equality from the observation that D_k^* will accept and produce the correct plaintext if and only if D accepts the first ciphertext and outputs p . \square

For the purposes of our next two examples, we make this construction even more precise. Consider a perfectly correct δ -tamper-evident AQECM scheme S whose messages are a single bit, which is to say that $\mathcal{M} = \{0, 1\}$. Let $S^\oplus = S \oplus \text{Triv}^{\mathcal{M},0} = (K^\oplus, E^\oplus, D^\oplus)$ be the scheme obtained from the construction of [Definition 61](#) where the group operation is taken to be the exclusive-or \oplus . By [Theorem 68](#), S^\oplus is a perfectly correct $2\sqrt{\delta}$ -tamper-evident AQECM scheme.

We now use S^\oplus to show separations between tamper evidence and two other notions: authentication and the encryption of quantum states. Note that by [Theorem 22](#), we can instantiate S^\oplus with a perfectly correct δ' -tamper-evident scheme S for any $\delta' > 0$. Hence, we can assume that S^\oplus is perfectly correct and δ -tamper evident for any $\delta > 0$.

²⁶We conjecture that S^* is actually δ -tamper evident.

7.3.1 Tamper Evidence Does Not Imply Authentication or Robustness

The notion of robustness for AQECM schemes was originally stated in Broadbent and Islam’s work on certified deletion [BI20], but it can be understood as a restriction of Barnum et al.’s notion of quantum authentication [BCG⁺02] from any arbitrary quantum states to only classical messages. In a nutshell, an AQECM scheme is robust if it is infeasible for an adversary to change a ciphertext in such a way that it will still be accepted by the decryption map, but that a different message will be recovered. We do not state a formal definition of this property.

As Gottesman noted, every quantum authentication scheme is itself a tamper-evident AQECM scheme [Got03]. Trivially, these are also robust AQECM schemes. It is also clear that there exist robust AQECMs which are not tamper evident. For example, simply consider any classical message authentication code which is information-theoretically secure (e.g.: [KL15, Sec. 4.6]). As the encodings produced by these message authentication codes are classical, it is infeasible to detect an adversary making and keeping a copy of them.

The above naturally leads to the following question: Does tamper evidence imply robustness? In the following, we sketch a proof that the answer is “no”. There are tamper-evident schemes which are not robust.

Consider the AQECM scheme S^\oplus as previous described in this section. Further consider the channel $\tilde{A} : \mathcal{L}(\mathbb{C} \otimes \mathbb{C}^{\{0,1\}}) \rightarrow \mathcal{L}(\mathbb{C} \otimes \mathbb{C}^{\{0,1\}})$ defined by

$$\rho \mapsto (I_{\mathbb{C}} \otimes X) \rho (I_{\mathbb{C}} \otimes X) \quad (219)$$

where $X = |0\rangle\langle 1| + |1\rangle\langle 0|$ is the bit-flip unitary operator. For any plaintext $b \in \{0, 1\}$, we see that

$$\begin{aligned} \tilde{A} \circ E_k^\oplus(m) &= \tilde{A} \left(\mathbb{E}_{p \leftarrow \{0,1\}} E_k(p) \otimes (p \oplus b) \right) \\ &= \mathbb{E}_{p \leftarrow \{0,1\}} E_k(p) \otimes (p \oplus b \oplus 1) \\ &= E_k^\oplus(b \oplus 1). \end{aligned} \quad (220)$$

As we assume that S is perfectly correct, S^\oplus is also perfectly correct. Hence, for any key k and message $b \in \{0, 1\}$, we have

$$\langle b \oplus 1 | \overline{D}_k^\oplus \circ \tilde{A} \circ E_k^\oplus(b) | b \oplus 1 \rangle = 1 \quad (221)$$

which is to say that an adversary using \tilde{A} can change the encoded plaintext undetected and with certainty. It follows S^\oplus cannot offer any non-trivial level of robustness.

7.3.2 Tamper Evidence Does Not Imply the Encryption of Quantum States

While AQECM schemes generally only guarantee correctness and various notions of security for *classical* messages, their encryption and decryption maps remain quantum channels. Hence, we can still inquire about their behaviours with respect to arbitrary quantum states.

We claim without further proof that S^\oplus is also perfectly correct with respect to any *quantum state*, in the sense that $D_k^\oplus \circ E_k^\oplus(\rho) = \rho \otimes |1\rangle\langle 1|$ for all keys k and quantum states $\rho \in \mathbb{C}^{\{0,1\}}$. This follows directly from the details of the construction of S^\oplus from Definition 61, in particular from the fact that the group operation is computed coherently.

On the other hand, recall that S^\oplus is $7\sqrt[4]{\delta}$ -encrypting for classical messages due to [Theorem 30](#) and the fact that it is $2\sqrt{\delta}$ -tamper evident. However, we claim that it offers no non-trivial level of security as an encryption scheme for arbitrary quantum states. This results from the fact that the classical one-time-pad fails to change certain quantum states.

More precisely, going through the details of the construction in [Definition 61](#), we see that the unitary U_\oplus which coherently computes the group operation is, here, simply the controlled-not linear operator CNOT which maps $|b, b'\rangle$ to $|b, b \oplus b'\rangle$ for any $b, b' \in \{0, 1\}$. Thus, for any key k and state ρ , we have that

$$E_k^\oplus(\rho) = \mathbb{E}_{p \leftarrow \{0,1\}} (E_k \otimes \text{Id}_{\mathbb{C}\{0,1\}}) \text{CNOT}(p \otimes \rho) \text{CNOT}^\dagger = \mathbb{E}_{p \leftarrow \{0,1\}} E_k(p) \otimes X^p \rho X^p \quad (222)$$

where $X = |0\rangle\langle 1| + |1\rangle\langle 0|$ is once again the bit-flip unitary operator.

Consider now the states $|+\rangle = \frac{1}{\sqrt{2}}(|0\rangle + |1\rangle)$ and $|-\rangle = \frac{1}{\sqrt{2}}(|0\rangle - |1\rangle)$. Note that both resulting density operator $|+\rangle\langle +|$ and $|-\rangle\langle -|$ are invariant under conjugation by X . Hence, for any two keys k and k' , we have that

$$\begin{aligned} \frac{1}{2} \|E_k^\oplus(|+\rangle\langle +|) - E_{k'}^\oplus(|-\rangle\langle -|)\|_1 &= \frac{1}{2} \left\| \mathbb{E}_{p \leftarrow \{0,1\}} E_k(p) \otimes |+\rangle\langle +| - \mathbb{E}_{p \leftarrow \{0,1\}} E_{k'}(p) \otimes |-\rangle\langle -| \right\|_1 \\ &\geq \frac{1}{2} \| |+\rangle\langle +| - |-\rangle\langle -| \|_1 \\ &= 1 \end{aligned} \quad (223)$$

where the inequality follows by tracing out the ciphertext from S and the last equality from [Lemma 4](#) and $\langle +|-\rangle = 0$. In other words, the encodings of $|+\rangle$ and $|-\rangle$ under E_k^\oplus for any keys remain perfectly distinguishable. Hence, this AQECM scheme does not offer any non-trivial level of security as an encryption scheme for arbitrary quantum states.

References

- [Aar16] S. Aaronson. The complexity of quantum states and transformations: From quantum money to black holes. E-print arXiv:1607.05256 [quant-ph], 2016. [doi:10.48550/arXiv/1607.05256](https://doi.org/10.48550/arXiv/1607.05256)
- [AC12] S. Aaronson and P. Christiano. Quantum money from hidden subspaces. In *STOC '12: Proceedings of the forty-fourth ACM symposium on Theory of computing*, pp. 41–60, 2012. [doi:10.1145/2213977.2213983](https://doi.org/10.1145/2213977.2213983)
- [AMTdW00] A. Ambainis, M. Mosca, A. Tapp, and R. de Wolf. Private quantum channels. In *41st Annual Symposium on Foundations of Computer Science (FOCS 2000)*, pp. 547–553, 2000. [doi:10.1109/SFCS.2000.892142](https://doi.org/10.1109/SFCS.2000.892142)
- [Bar20] E. Barker. Recommendation for key management: Part 1 – general. Technical Report SP 800-57 Part 1 Rev. 5, National Institute of Standards and Technology, 2020. [doi:10.6028/NIST.SP.800-57pt1r5](https://doi.org/10.6028/NIST.SP.800-57pt1r5)

- [BB84] C. H. Bennett and G. Brassard. Quantum cryptography: Public key distribution and coin tossing. In *International Conference on Computers, Systems and Signal Processing*, pp. 175–179, 1984.
- [BCG⁺02] H. Barnum, C. Crépeau, D. Gottesman, A. Smith, and A. Tapp. Authentication of quantum messages. In *43rd Annual Symposium on Foundations of Computer Science (FOCS 2002)*, pp. 449–485, 2002.
[doi:10.1109/SFCS.2002.1181969](https://doi.org/10.1109/SFCS.2002.1181969)
- [BI20] A. Broadbent and R. Islam. Quantum encryption with certified deletion. In *Theory of Cryptography (TCC 2020)*, vol. 3, pp. 92–122, 2020.
[doi:10.1007/978-3-030-64381-2_4](https://doi.org/10.1007/978-3-030-64381-2_4)
- [Bil95] P. Billingsley. *Probability and Measure*. John Wiley & Sons, 3rd edition, 1995.
- [BK23] J. Bartusek and D. Khurana. Cryptography with certified deletion. In *Advances in Cryptology — CRYPTO 2023*, vol. 5, pp. 192–223, 2023.
[doi:10.1007/978-3-031-38554-4_7](https://doi.org/10.1007/978-3-031-38554-4_7)
- [BL20] A. Broadbent and S. Lord. Uncloneable quantum encryption via oracles. In *15th Conference on the Theory of Quantum Computation, Communication, and Cryptography (TQC 2020)*, art. 4, 2020.
[doi:10.4230/LIPIcs.TQC.2020.4](https://doi.org/10.4230/LIPIcs.TQC.2020.4)
- [Bra05] G. Brassard. Brief history of quantum cryptography: A personal perspective. In *IEEE Information Theory Workshop on Theory and Practice in Information-Theoretic Security*, pp. 19–23, 2005.
[doi:10.1109/ITWTPI.2005.1543949](https://doi.org/10.1109/ITWTPI.2005.1543949)
- [CRW19] X. Coiteux-Roy and S. Wolf. Proving erasure. In *IEEE International Symposium on Information Theory—ISIT 2019*, pp. 832–836, 2019.
[doi:10.1109/ISIT.2019.8849661](https://doi.org/10.1109/ISIT.2019.8849661)
- [Die82] D. Dieks. Communication by EPR devices. *Physics Letters A*, vol. 92, no. 6, pp. 271–272, 1982.
[doi:10.1016/0375-9601\(82\)90084-6](https://doi.org/10.1016/0375-9601(82)90084-6)
- [Dir39] P. A. M. Dirac. A new notation for quantum mechanics. *Mathematical Proceedings of the Cambridge Philosophical Society*, vol. 35, no. 3, pp. 416–418, 1939.
[doi:10.107/S0305004100021162](https://doi.org/10.107/S0305004100021162)
- [FdG99] C. A. Fuchs and J. V. de Graaf. Cryptographic distinguishability measures for quantum-mechanical states. *IEEE Transactions on Information Theory*, vol. 45, no. 4, pp. 1216–1227, 1999.
[doi:10.1109/18.761271](https://doi.org/10.1109/18.761271)
- [FS17] S. Fehr and L. Salvail. Quantum authentication and encryption with key recycling. In *Advances in Cryptology — EUROCRYPT 2017*, pp. 311–338,

2017.
[doi:10.1007/978-3-319-56617-7_11](https://doi.org/10.1007/978-3-319-56617-7_11)
- [Fuc96] C. A. Fuchs. Information gain vs. state disturbance in quantum theory. 1996.
[arXiv:quant-ph/9611010](https://arxiv.org/abs/quant-ph/9611010)
- [Got03] D. Gottesman. Uncloneable encryption. *Quantum Information & Computation*, vol. 3, no. 6, pp. 581–602, 2003.
[doi:10.26421/QIC3.6-2](https://doi.org/10.26421/QIC3.6-2)
- [Got11] D. Gottesman. Answer to “Rigorous security proof for Wiesner’s quantum money?”. Theoretical Computer Science Stack Exchange, 2011.
<https://cstheory.stackexchange.com/q/11364>
- [HMNY21] T. Hiroka, T. Morimae, R. Nishimaki, and T. Yamakawa. Quantum encryption with certified deletion, revisited: Public key, attribute-based, and classical communication. pp. 606–636, 2021.
[doi:10.1007/978-3-030-92062-3_21](https://doi.org/10.1007/978-3-030-92062-3_21)
- [KL15] J. Katz and Y. Lindell. *Introduction to Modern Cryptography*. CRC Press, 2nd edition, 2015.
- [KT23] S. Kundu and E. Y.-T. Tan. Composably secure device-independent encryption with certified deletion. *Quantum*, vol. 7, no. 1047, 2023.
[doi:10.22331/q-2023-07-06-1047](https://doi.org/10.22331/q-2023-07-06-1047)
- [LŠ20] D. Leermaker and B. Škorić. Qubit-based unclonable encryption with key recycling. 2020.
[arXiv:2004.04084](https://arxiv.org/abs/2004.04084) [quant-ph]
- [Lut10] A. Lutomirski. An online attack against Wiesner’s quantum money. 2010.
[arXiv:1010.0256](https://arxiv.org/abs/1010.0256) [quant-ph]
- [MVW13] A. Molina, T. Vidick, and J. Watrous. Optimal counterfeiting attacks and generalizations for Wiesner’s quantum money. In *Theory of Quantum Computation, Communication, and Cryptography (TQC 2012)*, pp. 45–64, 2013.
[doi:10.1007/978-3-642-35656-8_4](https://doi.org/10.1007/978-3-642-35656-8_4)
- [NC10] M. A. Nielsen and I. L. Chuang. *Quantum Computation and Quantum Information*. Cambridge University Press, 10th anniversary edition, 2010.
[doi:10.1017/CB09780511976667](https://doi.org/10.1017/CB09780511976667)
- [NSBU16] D. Nagaj, O. Sattah, A. Brodutch, and D. Unruh. An adaptive attack on Wiesner’s quantum money. *Quantum Information & Computation*, vol. 16, pp. 1048–1070, 2016.
[doi:10.26421/QIC16.11-12-7](https://doi.org/10.26421/QIC16.11-12-7)
- [Ort18] J. Ortigoso. Twelve years before the quantum no-cloning theorem. *American Journal of Physics*, vol. 86, no. 3, pp. 201–205, 2018.
[doi:10.1119/1.5021356](https://doi.org/10.1119/1.5021356)

- [Par70] J. L. Park. The concept of transition in quantum mechanics. *Foundations of Physics*, vol. 1, no. 1, pp. 23–33, 1970.
[doi:10.1007/BF00708652](https://doi.org/10.1007/BF00708652)
- [Sha79] A. Shamir. How to share a secret. *Communications of the ACM*, vol. 22, no. 11, pp. 612–613, 1979.
[doi:10.1145/359168.359176](https://doi.org/10.1145/359168.359176)
- [SP00] P. W. Shor and J. Preskill. Simple proof of security of the BB84 quantum key distribution protocol. *Physical Review Letters*, vol. 85, no. 2, pp. 441–444, 2000.
[doi:10.1103/physrevlett.85.441](https://doi.org/10.1103/physrevlett.85.441)
- [Unr15] D. Unruh. Revocable quantum timed-release encryption. *Journal of the ACM*, vol. 62, no. 6, art. 49, 2015.
[doi:10.1145/2817206](https://doi.org/10.1145/2817206)
- [vdVCRŠ22] B. van der Vecht, X. Coiteux-Roy, and B. Škorić. Can’t touch this: Unconditional tamper evidence from short keys. *Quantum Information & Computation*, vol. 22, no. 5&6, pp. 385–407, 2022.
[doi:10.26421/QIC22.5-6-1](https://doi.org/10.26421/QIC22.5-6-1)
- [VV14] U. Vazirani and T. Vidick. Fully device-independent quantum key distribution. *Physical Review Letters*, vol. 113, no. 14, p. 140501, 2014.
[doi:10.1103/PhysRevLett.113.140501](https://doi.org/10.1103/PhysRevLett.113.140501)
- [Wat18] J. Watrous. *The Theory of Quantum Information*. Cambridge University Press, 2018.
[doi:10.1017/9781316848142](https://doi.org/10.1017/9781316848142)
- [Wie83] S. Wiesner. Conjugate coding. *ACM SIGACT News*, vol. 15, no. 1, pp. 78–88, 1983.
[doi:10.1145/1008908.1008920](https://doi.org/10.1145/1008908.1008920)
- [Wil17] M. M. Wilde. *Quantum Information Theory*. Cambridge University Press, second edition, 2017.
[doi:10.1017/9781316809976](https://doi.org/10.1017/9781316809976)
- [Win99] A. Winter. Coding theorem and strong converse for quantum channels. *IEEE Transactions on Information Theory*, vol. 45, no. 7, pp. 2481–2485, 1999.
[doi:10.1109/18.796385](https://doi.org/10.1109/18.796385)
- [WZ82] W. K. Wootters and W. H. Zurek. A single quantum cannot be cloned. *Nature*, vol. 299, pp. 802–803, 1982.
[doi:10.1038/299802a0](https://doi.org/10.1038/299802a0)