

Compositional Design of Safety Controllers for Large-scale Stochastic Hybrid Systems

MAHDIEH ZAKER, OMID AKBARZADEH, BEHRAD SAMARI,
AND ABOLFAZL LAVAEI

SCHOOL OF COMPUTING, NEWCASTLE UNIVERSITY, UNITED KINGDOM

{M.ZAKER2, O.AKBARZADEH2, B.SAMARI2, ABOLFAZL.LAVAEI}@NEWCASTLE.AC.UK

ABSTRACT. In this work, we propose a compositional scheme based on *small-gain reasoning* for the safety controller synthesis of interconnected stochastic hybrid systems with both continuous evolutions and instantaneous jumps. In our proposed setting, we first offer an augmented scheme to represent each stochastic hybrid subsystem with continuous and discrete evolutions in a unified framework, ensuring that the state trajectories match those of the original hybrid systems. We then introduce the concept of augmented *control sub-barrier certificates* (A-CSBC) for each subsystem, which allows the construction of augmented *control barrier certificates* (A-CBC) for interconnected systems and their safety controllers under small-gain compositional conditions. We eventually leverage the constructed A-CBC and quantify a guaranteed probabilistic bound across the safety of the interconnected system. While the computational complexity of designing a barrier certificate and its safety controller grows *polynomially* with network dimension using sum-of-squares (SOS) optimization program, our compositional approach significantly reduces it to a *linear* scale with respect to the number of subsystems. We verify the efficacy of our proposed approach over an interconnected stochastic hybrid system composed of 1000 nonlinear subsystems.

1. INTRODUCTION

Stochastic hybrid systems (SHS) [BLE⁺06, CL06] are complex heterogeneous models, spanning a wide range of safety-critical applications, in which discrete dynamics describe computation and communication parts and continuous models capture physical components. Providing a formal verification and controller synthesis framework for this type of complex heterogeneous systems is naturally very challenging primarily due to (i) the stochastic nature of dynamics, (ii) the tight interaction between continuous and discrete components (in both space and time), (iii) the large dimension of state/input sets, and (iv) the need to manage complex logic requirements [BK08].

Discretization-based approaches. In order to deal with the above-mentioned difficulties, one potential solution, proposed in the relevant literature, is to approximate original models by a simpler one with either

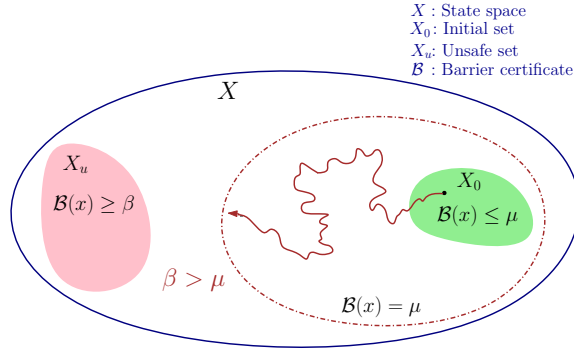

FIGURE 1. A control barrier certificate for stochastic dynamical systems. The initial level set of CBC is denoted by dashed line (*i.e.*, $\mathcal{B}(x) = \mu$).

a lower dimension (*a.k.a.*, infinite abstractions) or with discrete-state sets (*a.k.a.*, finite abstractions) [JP09, APLS08]. On the downside, the existing abstraction-based techniques rely on discretizing state/input sets and are not applicable to real-world high-dimensional systems due to the state-explosion problem. To make the abstraction-based techniques more scalable, compositional approaches have been proposed in the relevant literature that construct abstractions of large-scale systems based on those of smaller subsystems [LZ22, HHHK13, NZ20, LSAZ22, Lav24].

Discretization-free approaches. To mitigate the computational complexity arising from abstraction-based approaches, control barrier certificates (CBC), a promising *discretization-free approach*, have garnered significant attention in recent years for the formal analysis of complex dynamical systems. Specifically, barrier certificates are Lyapunov-like functions whose initial level set separates an unsafe region from all system trajectories starting from a set of initial states. Consequently, the existence of such a function provides a (probabilistic) safety certificate over the system (cf. Fig. 1). This approach has been initially proposed by [PJ04, PJP07] and then widely employed for formal verification and synthesis of non-stochastic [BWAE15, ACE⁺19] and stochastic dynamical systems [ZRHH10, ASBA19, SDC19, Cla19, NZ22, LF24, NPNS24, ALZ22, JLZ22, WHL24], to name a few.

Innovative findings. Despite the extensive above-mentioned literature on barrier certificate construction, there are no results available for *large-scale stochastic hybrid systems*. Our primary contribution is to propose a *compositional scheme* for the safety controller synthesis of interconnected SHS with both continuous evolutions, governed by stochastic differential equations with Brownian motions and Poisson processes, and instantaneous jumps, modeled by stochastic difference equations with additive noises. In our proposed setting, we first introduce an augmented framework to recast each stochastic hybrid subsystem with continuous and discrete evolutions via a unified framework, spanning both scenarios. We then introduce notions of augmented

control sub-barrier certificates, computed for each subsystem, using which one can construct augmented *control barrier certificates* for interconnected systems together with their safety controllers under some small-gain compositional conditions. We eventually leverage the constructed augmented control barrier certificate and offer a certified probabilistic bound across the safety of the interconnected system. We verify the usefulness of our proposed approaches by applying them to an interconnected stochastic hybrid system consisting of 1000 nonlinear subsystems. While the primary results of this work were initially presented in [LSF22], they are limited to monolithic systems and cannot handle models with more than six state dimensions due to the computational complexity involved in searching for control barrier certificates. In contrast, we propose here an innovative compositional technique to address large-scale SHS by constructing an augmented control barrier certificate for the interconnected system based on certificates of individual subsystems (cf. the 1000-dimensional case study). While the computational complexity of designing a barrier certificate and its safety controller in [LSF22] grows polynomially with system dimension using sum-of-squares (SOS) optimization program, our compositional approach here significantly reduces it to a linear scale with respect to the number of subsystems. Additionally, we present the proofs for all statements that were not included in [LSF22].

Organization. The rest of the paper is structured as follows. Section 2 provides mathematical preliminaries and notations, and also the formal definition of (augmented) stochastic hybrid systems. In Section 3, we introduce notions of augmented control sub-barrier and barrier certificates for, respectively, augmented stochastic hybrid systems with and without disturbance signals. In Section 4, we propose a compositional approach based on small-gain reasoning to construct an augmented control barrier certificate for the interconnected system based on the certificates of individual subsystems. In Section 5, we provide required conditions for the construction of augmented control sub-barrier certificates based on control barrier certificates of original SHS. In Section 6, we employ sum-of-squares (SOS) optimization techniques to search for control barrier certificates of SHS. Section 7 verifies the proposed approaches over a nonlinear interconnected SHS, and concluding remarks are finally provided in Section 8.

2. STOCHASTIC HYBRID SYSTEMS

2.1. Notation. Sets of non-negative and positive integers are, respectively, denoted by $\mathbb{N} := \{0, 1, 2, \dots\}$ and $\mathbb{N}^+ = \{1, 2, \dots\}$. Sets of real, positive and non-negative real numbers are represented by $\mathbb{R}, \mathbb{R}^+,$ and \mathbb{R}_0^+ , respectively. Given N vectors $x_i \in \mathbb{R}^{n_i}$, $x = [x_1; \dots; x_N]$ represents the corresponding vector of dimension $\sum_i n_i$. Given a vector $x \in \mathbb{R}^n$, we define the Hadamard power as $x^{om} = [x_1^m \dots x_n^m]^\top$ for $m \in \mathbb{N}$. A (block) diagonal matrix in $\mathbb{R}^{N \times N}$ with diagonal matrix entries (A_1, \dots, A_N) and scalar entries (a_1, \dots, a_N) is denoted by $\text{blkdiag}(A_1, \dots, A_N)$ and $\text{diag}(a_1, \dots, a_N)$, respectively. We denote the Euclidean norm of a vector $x \in \mathbb{R}^n$ by $\|x\|$. Given sets $X_i, i \in \{1, \dots, N\}$, their Cartesian product is denoted by $\prod_{i=1}^N X_i$. Symbol \mathbb{I}_n denotes the

identity matrix in $\mathbb{R}^{n \times n}$. Given a measurable function $f : \mathbb{N} \rightarrow \mathbb{R}^n$, the (essential) supremum of f is denoted by $\|f\|_\infty := (\text{ess})\sup\{\|f(k)\|, k \geq 0\}$.

2.2. Preliminaries. Given a probability space $(\Omega, \mathcal{F}_\Omega, \mathbb{P}_\Omega)$, with Ω being the sample space, \mathcal{F}_Ω a sigma-algebra on Ω , and \mathbb{P}_Ω a probability measure, we assume that $(\Omega, \mathcal{F}_\Omega, \mathbb{P}_\Omega)$ is endowed with a filtration $\mathbb{F} = (\mathcal{F}_s)_{s \geq 0}$ fulfilling conditions of completeness and right continuity. We consider $(\mathbb{W}_s)_{s \geq 0}$ as a \mathbf{b} -dimensional \mathbb{F} -Brownian motion and $(\mathbb{P}_s)_{s \geq 0}$ as an \mathbf{r} -dimensional \mathbb{F} -Poisson process. The Poisson process and Brownian motion are considered to be mutually independent. The Poisson process $\mathbb{P}_s = [\mathbb{P}_s^1; \dots; \mathbb{P}_s^r]$ models \mathbf{r} events with independent occurrences.

2.3. Stochastic Hybrid Systems. In this work, our focus lies on stochastic hybrid systems, treating them as *individual subsystems*, as delineated in the following definition.

Definition 2.1. A stochastic hybrid system (SHS) Φ_i is characterized by $\Phi_i = (X_i, U_i, \mathcal{U}_i, W_i, \mathcal{W}_i, \sigma_i, \rho_i, f_{1_i}, \varsigma_i, f_{2_i})$, where:

- $X_i \subseteq \mathbb{R}^{n_i}$ is the state set of SHS;
- $U_i \subseteq \mathbb{R}^{m_i}$ is the input set of SHS;
- \mathcal{U}_i is the set of all measurable bounded input functions $\nu_i : \mathbb{R}_0^+ \rightarrow U_i$;
- $W_i \subseteq \mathbb{R}^{p_i}$ is the disturbance set of SHS (which is utilized later for the sake of interconnection);
- \mathcal{W}_i is the set of all measurable bounded disturbance functions $w_i : \mathbb{R}_0^+ \rightarrow W_i$;
- $\sigma_i : \mathbb{R}^{n_i} \rightarrow \mathbb{R}^{n_i \times b_i}$ is the diffusion term which is globally Lipschitz continuous;
- $\rho_i : \mathbb{R}^{n_i} \rightarrow \mathbb{R}^{n_i \times r_i}$ is the reset term which is globally Lipschitz continuous;
- $f_{1_i} : X_i \times U_i \times W_i \rightarrow X_i$ is the drift term which is globally Lipschitz continuous;
- ς_i is a sequence of independent and identically distributed (i.i.d.) random variables from the sample space Ω_i to the measurable space $(\mathcal{V}_{\varsigma_i}, \mathcal{F}_{\varsigma_i})$:

$$\varsigma_i := \left\{ \varsigma_i(\cdot) : (\Omega_i, \mathcal{F}_{\Omega_i}) \rightarrow (\mathcal{V}_{\varsigma_i}, \mathcal{F}_{\varsigma_i}) \right\};$$

- $f_{2_i} : X_i \times U_i \times W_i \times \mathcal{V}_{\varsigma_i} \rightarrow X_i$ is the transition map which is globally Lipschitz continuous.

The SHS Φ_i can be characterized by the following stochastic differential and difference equations:

$$\Phi_i : \begin{cases} dx_i(t) = f_{1_i}(x_i(t), \nu_i(t), w_i(t))dt + \sigma_i(x_i(t))d\mathbb{W}_t + \rho_i(x_i(t))d\mathbb{P}_t, & t \in \mathbb{R}_0^+ \setminus \Delta, \\ x_i(t) = f_{2_i}(x_i(t^-), \nu_i(t), w_i(t), \varsigma_i(t)), & t \in \Delta, \end{cases} \quad (2.1)$$

where $\Delta = \{t_k\}_{k \in \mathbb{N}}$ with $t_{k+1} - t_k \in \{\varepsilon_{1_i}\tau, \dots, \varepsilon_{2_i}\tau\}$ for jump parameters $\tau \in \mathbb{R}^+$ and $\varepsilon_{1_i}, \varepsilon_{2_i} \in \mathbb{N}^+$, $\varepsilon_{1_i} \leq \varepsilon_{2_i}$. Moreover, $f_{2_i}(x_i(t^-)) = \lim_{t \rightarrow t_k^-} f_{2_i}(x_i(t))$, indicating the value of $f_{2_i}(x_i(t))$ as t goes to t_k from left. Furthermore, $x_i : \mathbb{R}_0^+ \rightarrow \mathbb{R}^{n_i}$ is the state signal (right-continuous for all $t \in \mathbb{R}_0^+$) and $\nu_i(\cdot) \in \mathcal{U}_i, w_i(\cdot) \in \mathcal{W}_i$

are input and disturbance signals. The random sequence $x_{x_0, \nu_i, w_i}(t)$ fulfilling (2.1) is called the state trajectory (a.k.a. solution) of Φ_i at time $t \in \mathbb{R}_0^+$ under signals $\nu_i(\cdot), w_i(\cdot)$ starting from x_0 .

Given that control inputs in practice are often fed by a digital controller, we are interested here in sampled-data hybrid systems as

$$\mathcal{U}_{\tau_i} = \left\{ \nu_i: \mathbb{R}_0^+ \rightarrow U_i \mid \nu_i(t) = \nu_i(t_{k-1}), t \in [t_{k-1}, t_k], k \in \mathbb{N} \right\}, \quad (2.2)$$

with $t_k = k\tau$.

2.4. Interconnected SHS. Since the ultimate goal in this work is to synthesize a safety controller for an interconnected SHS, we provide next a formal definition for interconnected SHS without disturbance signals w that can be constructed as a composition of multiple SHS with disturbance signals.

Definition 2.2. Consider $N \in \mathbb{N}^+$ SHSs $\Phi_i = (X_i, U_i, \mathcal{U}_i, W_i, \mathcal{W}_i, \sigma_i, \rho_i, f_{1_i}, \varsigma_i, f_{2_i})$, with their disturbances partitioned as

$$w_i = [w_{i1}; \dots; w_{i(i-1)}; w_{i(i+1)}; \dots; w_{iN}]. \quad (2.3)$$

The interconnection of Φ_i is $\Phi = (X, U, \mathcal{U}, \sigma, \rho, f_1, \varsigma, f_2)$, denoted by $\mathcal{I}(\Phi_1, \dots, \Phi_N)$, such that $X = \prod_{i=1}^N X_i, U = \prod_{i=1}^N U_i, \sigma := \text{blkdiag}(\sigma_1(x_1), \dots, \sigma_N(x_N)), \rho := \text{blkdiag}(\rho_1(x_1), \dots, \rho_N(x_N)), f_1 := [f_{1_1}; \dots; f_{1_N}], f_2 := [f_{2_1}; \dots; f_{2_N}]$ and $\varsigma := [\varsigma_1; \dots; \varsigma_N]$, subjected to the following interconnection constraint:

$$\forall i, j \in \{1, \dots, N\}, i \neq j: w_{ij} = x_j, X_j \subseteq W_{ij}, \quad (2.4)$$

where $W_i := \prod_j W_{ij}$. Such an interconnected SHS can be described by

$$\Phi: \begin{cases} dx(t) = f_1(x(t), \nu(t))dt + \sigma(x(t))d\mathbb{W}_t + \rho(x(t))d\mathbb{P}_t, & t \in \mathbb{R}_0^+ \setminus \Delta, \\ x(t) = f_2(x(t^-), \nu(t), \varsigma(t)) & t \in \Delta. \end{cases} \quad (2.5)$$

The random sequence $x_{x_0, \nu}(t)$ fulfilling (2.5) is called the state trajectory of Φ at time $t \in \mathbb{R}_0^+$ under an input signal $\nu(\cdot)$ starting from x_0 .

An interconnection of two SHS Φ_i is schematically depicted in Fig. 2.

2.5. Augmented SHS. As it can be observed, the SHS in (2.1) encompasses both continuous and discrete evolutions, in which continuous behaviours are governed by stochastic differential equations with Brownian motions and Poisson processes, and instantaneous jumps are modelled by stochastic difference equations with additive noises. In the next definition, we provide a *unified framework* for SHS covering both continuous and discrete behaviours by adding an auxiliary variable ϑ_i to the state tuple of Φ_i as a counter, based on which an SHS is allowed or prevented from jump.

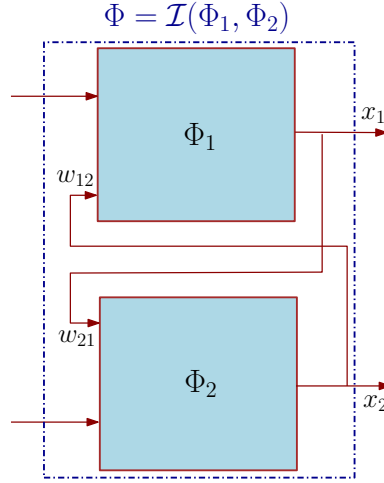
FIGURE 2. Interconnection of two SHS Φ_1, Φ_2 .

Definition 2.3. Consider an SHS $\Phi_i = (X_i, U_i, \mathcal{U}_i, W_i, \mathcal{W}_i, \sigma_i, \rho_i, f_{1_i}, \varsigma_i, f_{2_i})$ with jump parameters $(\tau, \varepsilon_{1_i}, \varepsilon_{2_i})$. An augmented SHS (A-SHS) $\mathcal{A}_i(\Phi_i)$ associated to Φ_i is characterized by $\mathcal{A}_i(\Phi_i) = (\mathbb{X}_i, \mathbb{U}_i, \mathbb{W}_i, \sigma_i, \rho_i, \varsigma_i, \mathbb{F}_i, \mathbb{Y}_i, \mathbb{H}_i)$, where:

- $\mathbb{X}_i = X_i \times \{0, \dots, \varepsilon_{2_i}\}$ is the state space of A-SHS, while $(x_i, \vartheta_i) \in \mathbb{X}_i$ indicates that the current state is x_i , and the time elapsed since the latest jump is ϑ_i ;
- $\mathbb{U}_i = \mathcal{U}_{\tau_i}$ is the input space of A-SHS;
- \mathbb{W}_i is the disturbance space of A-SHS;
- σ_i is the diffusion term;
- ρ_i is the reset term;
- ς_i is a sequence of i.i.d. random variables;
- $(x'_i, \vartheta'_i) = \mathbb{F}_i((x_i, \vartheta_i), \nu_i, w_i, \sigma_i, \rho_i, \varsigma_i)$ if and only if one of the following two cases holds:
 - (i) Flow case: $0 \leq \vartheta_i \leq \varepsilon_{2_i} - 1$, $x'_i = x_{x_i \nu_i w_i}(\tau^-)$, and $\vartheta'_i = \vartheta_i + 1$;
 - (ii) Jump case: $\varepsilon_{1_i} \leq \vartheta_i \leq \varepsilon_{2_i}$, $x'_i = f_{2_i}(x_i, \nu_i, w_i, \varsigma_i)$, and $\vartheta'_i = 0$;
- $\mathbb{Y}_i = \mathbb{R}^{n_i}$ is the output space of A-SHS;
- $\mathbb{H}_i : \mathbb{X}_i \rightarrow \mathbb{Y}_i$ is the output map defined as $\mathbb{H}_i(x_i, \vartheta_i) = x_i$.

Remark 2.4. Note that $(x'_i, \vartheta'_i) = \mathbb{F}_i((x_i, \vartheta_i), \nu_i, w_i, \sigma_i, \rho_i, \varsigma_i)$ in Definition 2.3 characterizes the evolution of A-SHS, in which \mathbb{F}_i is acquired based on one of the following two cases:

- if the counter ϑ_i is between 0 and $\varepsilon_{2_i} - 1$, then the state evolves based on the flow case as $x'_i = x_{x_i \nu_i w_i}(\tau^-)$, in which $x_{x_i \nu_i w_i}(\tau^-)$ is the solution of the stochastic differential equation $dx_i(t) = f_{1_i}(x_i(t), \nu_i(t), w_i(t))dt + \sigma_i(x_i(t))d\mathbb{W}_t + \rho_i(x_i(t))d\mathbb{P}_t$, which is well defined in the literature [ØS05]. In this case, the next counter is

increased as $\vartheta'_i = \vartheta_i + 1$;

- if the counter ϑ_i is between ε_{1_i} and ε_{2_i} , then the state evolves based on the jump case as $x'_i = f_{2_i}(x_i(t^-), \nu_i(t), w_i(t), \varsigma_i(t))$ and the counter is reset from zero as $\vartheta'_i = 0$.

In the following proposition, we demonstrate that the state trajectories of an A-SHS and its original SHS are equivalent. Consequently, we leverage the A-SHS as a unified framework that encompasses both continuous evolutions and instantaneous jumps, providing a more manageable model.

Proposition 2.5. *The state trajectory of Φ_i defined in (2.1) can be uniquely mapped to a state trajectory of $\mathcal{A}_i(\Phi_i)$ in Definition 2.3 and vice versa.*

Proof. To show the statement, let us define $\mathbf{X}_{x_{0_i}, \bar{\nu}_i, \bar{w}_i, \varkappa_i}$ and $\mathcal{A}_i(\mathbf{X})_{\bar{x}_{0_i}, \bar{\nu}_i, \bar{w}_i, \varkappa_i}$ as sets of state runs for, respectively, Φ_i and $\mathcal{A}_i(\Phi_i)$, where $\bar{\nu}_i = \{\nu_i(t), t \in \mathbb{R}_0^+\}$, $\bar{w}_i = \{w_i(t), t \in \mathbb{R}_0^+\}$, $\varkappa_i = \{\mathbb{W}_t, \mathbb{P}_t, \varsigma_i(t), t \in \mathbb{R}_0^+\}$, and $\bar{x}_{0_i} = (x_{0_i}, \vartheta_{0_i})$ (with $\vartheta_{0_i} = 0$ being the initial counter of A-SHS). The proof now consists of showing that for any run in $\mathbf{X}_{x_{0_i}, \bar{\nu}_i, \bar{w}_i, \varkappa_i}$, denoted by $x_{x_{0_i}, \bar{\nu}_i, \bar{w}_i, \varkappa_i}$, there exists a run in $\mathcal{A}_i(\mathbf{X})_{\bar{x}_{0_i}, \bar{\nu}_i, \bar{w}_i, \varkappa_i}$, denoted by $\mathcal{A}_i(x)_{\bar{x}_{0_i}, \bar{\nu}_i, \bar{w}_i, \varkappa_i}$, and vice versa. Since $x_{0_i}, \bar{\nu}_i, \bar{w}_i$ are given, one can construct $x_{x_{0_i}, \bar{\nu}_i, \bar{w}_i, \varkappa_i} \in \mathbf{X}_{x_{0_i}, \bar{\nu}_i, \bar{w}_i, \varkappa_i}$. Then by leveraging the definition of \mathbb{H}_i in Definition 2.3, we have $x_{x_{0_i}, \bar{\nu}_i, \bar{w}_i, \varkappa_i} = \mathcal{A}_i(x)_{\bar{x}_{0_i}, \bar{\nu}_i, \bar{w}_i, \varkappa_i} \in \mathcal{A}_i(\mathbf{X})_{\bar{x}_{0_i}, \bar{\nu}_i, \bar{w}_i, \varkappa_i}$. In other words, given an initial state x_{0_i} , input and disturbance sequences $\nu_i(\cdot), w_i(\cdot)$, and a realization of the noises $\mathbb{W}_t, \mathbb{P}_t, \varsigma_i(t)$, one can uniquely map the state trajectory of Φ_i to a state trajectory of $\mathcal{A}_i(\Phi_i)$. We now show the proof from the other side. Since $\bar{x}_{0_i} = (x_{0_i}, \vartheta_{0_i})$, one can construct $\mathcal{A}_i(x)_{\bar{x}_{0_i}, \bar{\nu}_i, \bar{w}_i, \varkappa_i} \in \mathcal{A}_i(\mathbf{X})_{\bar{x}_{0_i}, \bar{\nu}_i, \bar{w}_i, \varkappa_i}$. Similarly, by leveraging the definition of \mathbb{H}_i in Definition 2.3, we have $\mathcal{A}_i(x)_{\bar{x}_{0_i}, \bar{\nu}_i, \bar{w}_i, \varkappa_i} = x_{x_{0_i}, \bar{\nu}_i, \bar{w}_i, \varkappa_i} \in \mathbf{X}_{x_{0_i}, \bar{\nu}_i, \bar{w}_i, \varkappa_i}$. Then one can uniquely map the state trajectory of Φ_i to a state trajectory of $\mathcal{A}_i(\Phi_i)$ and vice versa, for the *same* initial conditions and realization of the noises, which completes the proof. ■

3. AUGMENTED CONTROL (SUB-)BARRIER CERTIFICATES

In this section, we introduce notions of augmented control sub-barrier and barrier certificates for, respectively, augmented SHS with and without disturbance signals. We then utilize those notions and quantify a guaranteed probabilistic bound over the safety of the interconnected SHS.

Definition 3.1. *Given an A-SHS $\mathcal{A}_i(\Phi_i) = (\mathbb{X}_i, \mathbb{U}_i, \mathbb{W}_i, \sigma_i, \rho_i, \varsigma_i, \mathbb{F}_i, \mathbb{Y}_i, \mathbb{H}_i)$, consider $\mathbb{X}_{0_i} = X_{0_i} \times \{0\}$, $\mathbb{X}_{u_i} = X_{u_i} \times \{0, \dots, \varepsilon_{2_i}\}$, as initial and unsafe regions of $\mathcal{A}_i(\Phi_i)$, respectively, with $X_{0_i}, X_{u_i} \subseteq X_i$ being initial and unsafe regions of Φ_i . A function $\mathcal{B}_i : \mathbb{X}_i \rightarrow \mathbb{R}_0^+$ is said to be an augmented control sub-barrier certificate*

(A-CSBC) for $\mathcal{A}_i(\Phi_i)$ if there exist $0 < \gamma_i < 1$, $\kappa_i \in \mathbb{R}^+$, $\mu_i, \beta_i, \varphi_i, \eta_i \in \mathbb{R}_0^+$, such that

$$\mathcal{B}_i(x_i, \vartheta_i) \geq \kappa_i \|x_i\|^2, \quad \forall (x_i, \vartheta_i) \in \mathbb{X}_i, \quad (3.1a)$$

$$\mathcal{B}_i(x_i, \vartheta_i) \leq \mu_i, \quad \forall (x_i, \vartheta_i) \in \mathbb{X}_{0_i}, \quad (3.1b)$$

$$\mathcal{B}_i(x_i, \vartheta_i) \geq \beta_i, \quad \forall (x_i, \vartheta_i) \in \mathbb{X}_{u_i}, \quad (3.1c)$$

and $\forall (x_i, \vartheta_i) \in \mathbb{X}_i$, $\exists \nu_i \in \mathbb{U}_i$, such that $\forall w_i = w_i(t_k) \in \mathbb{W}_i$, $(x'_i, \vartheta'_i) = \mathbb{F}_i((x_i, \vartheta_i), \nu_i, w_i, \sigma_i, \rho_i, \varsigma_i)$, and

$$\mathbb{E} \left[\mathcal{B}_i(x'_i, \vartheta'_i) \mid x_i, \nu_i, w_i, \vartheta_i \right] \leq \gamma_i \mathcal{B}_i(x_i, \vartheta_i) + \varphi_i \|w_i\|^2 + \eta_i, \quad (3.1d)$$

where \mathbb{E} is the expected value w.r.t ς_i under the one-step transition of $\mathcal{A}_i(\Phi_i)$.

Remark 3.2. The order of quantifiers used in condition (3.1d), specifically $\forall x_i \in X_i$, $\exists \nu_i \in U_i$, $\forall w_i \in W_i$, inherently facilitates the synthesis of fully-decentralized controllers for $\mathcal{A}_i(\Phi_i)$. This is because the control input ν_i is independent of the internal input w_i , which represents the state information of other subsystems. As a result, this independence offers considerable flexibility in designing controllers for large-scale networks.

We now provide a notion of augmented control barrier certificates for augmented SHS without disturbance signals, *i.e.*, interconnected A-SHS (cf. Definition 4.1).

Definition 3.3. Given an interconnected A-SHS $\mathcal{A}(\Phi) = (\mathbb{X}, \mathbb{U}, \sigma, \rho, \varsigma, \mathbb{F}, \mathbb{Y}, \mathbb{H})$ with initial and unsafe regions $\mathbb{X}_0, \mathbb{X}_u$, a function $\mathcal{B} : \mathbb{X} \rightarrow \mathbb{R}_0^+$ is said to be an augmented control barrier certificate (A-CBC) for $\mathcal{A}(\Phi)$ if there exist $0 < \gamma < 1$, $\mu, \beta, \eta \in \mathbb{R}_0^+$, with $\beta > \mu$, such that

$$\mathcal{B}(x, \vartheta) \leq \mu, \quad \forall (x, \vartheta) \in \mathbb{X}_0, \quad (3.2a)$$

$$\mathcal{B}(x, \vartheta) \geq \beta, \quad \forall (x, \vartheta) \in \mathbb{X}_u, \quad (3.2b)$$

and $\forall (x, \vartheta) \in \mathbb{X}$, $\exists \nu \in \mathbb{U}$, such that $(x', \vartheta') = \mathbb{F}((x, \vartheta), \nu, \sigma, \rho, \varsigma)$, and

$$\mathbb{E} \left[\mathcal{B}(x', \vartheta') \mid x, \nu, \vartheta \right] \leq \gamma \mathcal{B}(x, \vartheta) + \eta. \quad (3.2c)$$

Remark 3.4. It is important to note that merely satisfying conditions (3.1) does not guarantee the safety of the network. In particular, an A-CSBC captures the influence of disturbance inputs w_i through interaction gains φ_i in (3.1d), reflecting the impact of neighboring subsystems within the network topology. Under certain small-gain compositional conditions detailed in Section 4, these A-CSBCs are combined to form an A-CBC for the interconnected A-SHS, ensuring its safety. To do so, condition (3.1a) is crucial in deriving these compositional results (see (4.3)).

Note that $\beta > \mu$ is required in Definition 3.3 in order to ensure there is no intersection between initial and unsafe sets of interconnected A-SHS. The next theorem, borrowed from [Kus67] but adapted to A-SHS, shows

the usefulness of A-CBC by quantifying a guaranteed probabilistic bound on the safety of the interconnected SHS.

Theorem 3.5. *Given interconnected A-SHS $\mathcal{A}(\Phi) = (\mathbb{X}, \mathbb{U}, \sigma, \rho, \varsigma, \mathbb{F}, \mathbb{Y}, \mathbb{H})$, let \mathcal{B} be an A-CBC for $\mathcal{A}(\Phi)$. Then for any x_0 and ϑ_0 , the probability that the state trajectories of $\mathcal{A}(\Phi)$ reach the unsafe region \mathbb{X}_u within the finite-time horizon $k \in [0, \mathcal{T}]$ is computed as:*

$$\mathbb{P}\left\{x_{x_0\nu}(t_k) \in \mathbb{X}_u \text{ for some } k \in [0, \mathcal{T}] \mid x_0, \vartheta_0\right\} \leq \begin{cases} 1 - (1 - \frac{\mu}{\beta})(1 - \frac{\eta}{\beta})^{\mathcal{T}}, & \text{if } \beta \geq \frac{\eta}{1-\gamma}, \\ (\frac{\mu}{\beta})\gamma^{\mathcal{T}} + (\frac{\eta}{(1-\gamma)\beta})(1 - \gamma)^{\mathcal{T}}, & \text{if } \beta < \frac{\eta}{1-\gamma}. \end{cases} \quad (3.3)$$

If $\eta = 0$ in (3.2c) (i.e., \mathcal{B} being a nonnegative supermartingale), the results of (3.3) can be extended to infinite time horizons as

$$\mathbb{P}\left\{x_{x_0\nu}(t_k) \in \mathbb{X}_u \text{ for some } k \in [0, \infty) \mid x_0, \vartheta_0\right\} \leq \frac{\mu}{\beta}. \quad (3.4)$$

Proof. Based on condition (3.2b), we have $\mathbb{X}_u \subseteq \{(x, \vartheta) \in \mathbb{X} \mid \mathcal{B}(x, \vartheta) \geq \beta\}$. Then one has

$$\mathbb{P}\left\{(x(t_k), \vartheta(t_k)) \in \mathbb{X}_u \text{ for some } 0 \leq k \leq \mathcal{T} \mid x_0, \vartheta_0\right\} \leq \mathbb{P}\left\{\sup_{0 \leq k \leq \mathcal{T}} \mathcal{B}(x(t_k), \vartheta(t_k)) \geq \beta \mid x_0, \vartheta_0\right\}. \quad (3.5)$$

One can accordingly acquired the proposed bounds in (3.3) by applying [Kus67, Theorem 3, Chapter III] to (3.5) and employing conditions (3.2c) and (3.2a), respectively. Similarly, the proposed infinite horizon bound in (3.4) can be obtained by employing the results of [Kus67, Theorem 12, Chapter II]. ■

Searching for control barrier certificates for large-scale dynamical systems is in general computationally very expensive. This has been the main motivation in this work to propose A-CSBC for each $\mathcal{A}_i(\Phi_i)$ instead of searching for A-CBC over the interconnected A-SHS, which is not possible in practice. In the next section, we propose a compositional approach based on small-gain reasoning to construct an A-CBC of the interconnected A-SHS based on A-CSBC of individual subsystems.

4. COMPOSITIONAL CONSTRUCTION OF A-CBC

In this section, we analyze networks of A-SHS via small-gain reasoning and discuss how to construct an A-CBC of the interconnected A-SHS based on the corresponding A-CSBCs of individual subsystems. To do so, we first introduce a formal definition for the interconnected A-SHS similar to Definition 2.2.

Definition 4.1. *Given $N \in \mathbb{N}^+$ A-SHSs $\mathcal{A}_i(\Phi_i) = (\mathbb{X}_i, \mathbb{U}_i, \mathbb{W}_i, \sigma_i, \rho_i, \varsigma_i, \mathbb{F}_i, \mathbb{Y}_i, \mathbb{H}_i)$ with their disturbances partitioned similar to (2.3), the interconnection of $\mathcal{A}_i(\Phi_i)$, $\forall i \in \{1, \dots, N\}$, is $\mathcal{A}(\Phi) = (\mathbb{X}, \mathbb{U}, \sigma, \rho, \varsigma, \mathbb{F}, \mathbb{Y}, \mathbb{H})$, denoted by $\mathcal{I}(\mathcal{A}_1(\Phi_1), \dots, \mathcal{A}_N(\Phi_N))$, such that $\mathbb{X} := \prod_{i=1}^N \mathbb{X}_i$, $\mathbb{U} = \prod_{i=1}^N \mathbb{U}_i$, $\sigma := \text{blkdiag}(\sigma_1(x_1), \dots, \sigma_N(x_N))$, $\rho := \text{blkdiag}(\rho_1(x_1), \dots, \rho_N(x_N))$, $\varsigma := [\varsigma_1; \dots; \varsigma_N]$, $\mathbb{Y} := \prod_{i=1}^N \mathbb{Y}_i$, $\mathbb{H} = \prod_{i=1}^N \mathbb{H}_i$, and the map $\mathbb{F} = [\mathbb{F}_1; \dots; \mathbb{F}_N]$ is defined by $(x', \vartheta') = \mathbb{F}((x, \vartheta), \nu, \sigma, \rho, \varsigma)$ if and only if, for any $i \in \{1, \dots, N\}$:*

- (i) *Flow case:* $0 \leq \vartheta_i \leq \varepsilon_{2_i} - 1$, $x'_i = x_{x_i \nu_i w_i}(\tau^-)$, and $\vartheta'_i = \vartheta_i + 1$;
(ii) *Jump case:* $\varepsilon_{1_i} \leq \vartheta_i \leq \varepsilon_{2_i}$, $x'_i = f_{2_i}(x_i, \nu_i, w_i, \varsigma_i)$, and $\vartheta'_i = 0$;

where $x = [x_1; \dots; x_N]$, $\vartheta = [\vartheta_1; \dots; \vartheta_N]$, $\varepsilon_1 = [\varepsilon_{1_1}; \dots; \varepsilon_{1_N}]$, $\varepsilon_2 = [\varepsilon_{2_1}; \dots; \varepsilon_{2_N}]$ and subjected to the following interconnection constraint:

$$\forall i, j \in \{1, \dots, N\}, i \neq j: w_{ij} = x_j, \mathbb{X}_j \subseteq \mathbb{W}_{ij},$$

where $\mathbb{W}_i := \prod_j \mathbb{W}_{ij}$.

In the next theorem, we propose the main compositionality result of the work, using which one can compositionally construct an A-CBC for the interconnected A-SHS based on A-CSBCs of individual subsystems. To do so, we first define $\Theta := \text{diag}(\theta_1, \dots, \theta_N)$ with $\theta_i = 1 - \gamma_i$, and $\Psi := \{\psi_{ij}\}$ with $\psi_{ij} = \frac{\varphi_i}{\kappa_j}$, where $\psi_{ii} = 0$, $\forall i \in \{1, \dots, N\}$.

Theorem 4.2. *Consider an interconnected A-SHS $\mathcal{I}(\mathcal{A}_1(\Phi_1), \dots, \mathcal{A}_N(\Phi_N))$ induced by $N \in \mathbb{N}^+$ A-SHSs $\mathcal{A}_i(\Phi_i)$. Suppose that each $\mathcal{A}_i(\Phi_i)$ admits an A-CSBC \mathcal{B}_i , as defined in Definition 3.1. For a vector ξ with $\xi_i > 0, \forall i \in \{1, \dots, N\}$, if*

$$\xi^\top (-\Theta + \Psi) := [\xi_1 \Gamma_1; \dots; \xi_N \Gamma_N]^\top < 0, \quad (4.1a)$$

$$\sum_{i=1}^N \xi_i \beta_i > \sum_{i=1}^N \xi_i \mu_i, \quad (4.1b)$$

then

$$\mathcal{B}(x, \vartheta) := \sum_{i=1}^N \xi_i \mathcal{B}_i(x_i, \vartheta_i) \quad (4.2)$$

is an A-CBC for the interconnected A-SHS with the initial and unsafe sets $\mathbb{X}_0 := \prod_{i=1}^N \mathbb{X}_{0_i}$, $\mathbb{X}_u := \prod_{i=1}^N \mathbb{X}_{u_i}$, with

$$\beta := \sum_{i=1}^N \xi_i \beta_i, \quad \mu := \sum_{i=1}^N \xi_i \mu_i, \quad \eta := \sum_{i=1}^N \xi_i \eta_i, \quad \gamma := 1 + \Gamma, \quad \text{with } \max_{1 \leq i \leq N} \Gamma_i < \Gamma < 0, \quad \text{and } \Gamma \in (-1, 0).$$

Proof. We first show that conditions (3.2a)-(3.2b) hold true. For any $(x, \vartheta) \in \mathbb{X}_0 = \prod_{i=1}^N \mathbb{X}_{0_i}$ and from (3.1b), one has

$$\mathcal{B}(x, \vartheta) = \sum_{i=1}^N \xi_i \mathcal{B}_i(x_i, \vartheta_i) \leq \sum_{i=1}^N \xi_i \mu_i = \mu.$$

Moreover, for any $(x, \vartheta) \in \mathbb{X}_u = \prod_{i=1}^N \mathbb{X}_{u_i}$ and from (3.1c), we have

$$\mathcal{B}(x, \vartheta) = \sum_{i=1}^N \xi_i \mathcal{B}_i(x_i, \vartheta_i) \geq \sum_{i=1}^N \xi_i \beta_i = \beta,$$

$$\begin{aligned}
\mathbb{E} \left[\mathcal{B}(x', \vartheta') \mid x, \nu, \vartheta \right] &= \mathbb{E} \left[\sum_{i=1}^N \xi_i \mathcal{B}_i(x_i, \vartheta_i) \mid x, \nu, \vartheta \right] = \sum_{i=1}^N \xi_i \mathbb{E} \left[\mathcal{B}_i(x_i, \vartheta_i) \mid x, \nu, \vartheta \right] = \sum_{i=1}^N \xi_i \mathbb{E} \left[\mathcal{B}_i(x_i, \vartheta_i) \mid x_i, \nu_i, w_i, \vartheta_i \right] \\
&\leq \sum_{i=1}^N \xi_i (\gamma_i \mathcal{B}_i(x_i, \vartheta_i) + \varphi_i \|w_i\|^2 + \eta_i) \leq \sum_{i=1}^N \xi_i (\gamma_i \mathcal{B}_i(x_i, \vartheta_i) + \varphi_i \sum_{j=1, i \neq j}^N \|w_{ij}\|^2 + \eta_i) \\
&= \sum_{i=1}^N \xi_i (\gamma_i \mathcal{B}_i(x_i, \vartheta_i) + \varphi_i \sum_{j=1, i \neq j}^N \|x_j\|^2 + \eta_i) \leq \sum_{i=1}^N \xi_i (\gamma_i \mathcal{B}_i(x_i, \vartheta_i) + \sum_{j=1, i \neq j}^N \frac{\varphi_i}{\kappa_j} \mathcal{B}_j(x_j, \vartheta_j) + \eta_i) \\
&= \sum_{i=1}^N \xi_i \mathcal{B}_i(x_i, \vartheta_i) + \sum_{i=1}^N \xi_i (-\theta_i \mathcal{B}_i(x_i, \vartheta_i) + \sum_{j=1, i \neq j}^N \psi_{ij} \mathcal{B}_j(x_j, \vartheta_j) + \eta_i) \\
&= \mathcal{B}(x, \vartheta) + \xi^\top (-\Theta + \Psi) \underbrace{[\mathcal{B}_1(x_1, \vartheta_1); \dots; \mathcal{B}_N(x_N, \vartheta_N)]}_{\tilde{\mathcal{B}}(x, \vartheta)} + \sum_{i=1}^N \xi_i \eta_i \leq \underbrace{(1 + \Gamma)}_{\gamma} \mathcal{B}(x, \vartheta) + \eta. \tag{4.3}
\end{aligned}$$

implying that conditions (3.2a)-(3.2b) are satisfied with $\mu = \sum_{i=1}^N \xi_i \mu_i$ and $\beta = \sum_{i=1}^N \xi_i \beta_i$. Note that $\beta > \mu$ according to (4.1b).

Now we proceed with showing that condition (3.2c) holds, as well. By leveraging conditions (3.1a),(4.1a), one can acquire the chain of inequalities in (4.3). By defining

$$\gamma s := \max \left\{ s + \xi^\top (-\Theta + \Psi) \tilde{\mathcal{B}}(x, \vartheta) \mid \xi^\top \tilde{\mathcal{B}}(x, \vartheta) = s \right\}, \quad \eta := \sum_{i=1}^N \xi_i \eta_i,$$

with $\tilde{\mathcal{B}}(x, \vartheta) = [\mathcal{B}_1(x_1, \vartheta_1); \dots; \mathcal{B}_N(x_N, \vartheta_N)]$, condition (3.2c) is also met. The only remaining part is to show that $\gamma = 1 + \Gamma$ and $0 < \gamma < 1$. Given that $\xi^\top (-\Theta + \Psi) := [\xi_1 \Gamma_1; \dots; \xi_N \Gamma_N]^\top < 0$, and $\max_{1 \leq i \leq N} \Gamma_i < \Gamma < 0$ with $\Gamma \in (-1, 0)$, we have

$$\begin{aligned}
\gamma s &= s + \xi^\top (-\Theta + \Psi) \tilde{\mathcal{B}}(x, \vartheta) \\
&= s + [\xi_1 \Gamma_1; \dots; \xi_N \Gamma_N]^\top [\mathcal{B}_1(x_1, \vartheta_1); \dots; \mathcal{B}_N(x_N, \vartheta_N)] \\
&= s + \xi_1 \Gamma_1 \mathcal{B}_1(x_1, \vartheta_1) + \dots + \xi_N \Gamma_N \mathcal{B}_N(x_N, \vartheta_N) \\
&\leq s + \Gamma (\xi_1 \mathcal{B}_1(x_1, \vartheta_1) + \dots + \xi_N \mathcal{B}_N(x_N, \vartheta_N)) \\
&= s + \Gamma s = (1 + \Gamma) s.
\end{aligned}$$

Therefore, $\gamma s \leq (1 + \Gamma) s$, and consequently $\gamma \leq 1 + \Gamma$. Since $\max_{1 \leq i \leq N} \Gamma_i < \Gamma < 0$ with $\Gamma \in (-1, 0)$, then $0 < \gamma = 1 + \Gamma < 1$. Hence, \mathcal{B} is an A-CBC for $\mathcal{I}(\mathcal{A}_1(\Phi_1), \dots, \mathcal{A}_N(\Phi_N))$, which concludes the proof. \blacksquare

As demonstrated in Theorem 4.2, under the compositionality conditions of (4.1a)-(4.1b), an A-CBC for the interconnected A-SHS can be compositionally constructed based on A-CSBCs of individual subsystems. In the next section, we provide the necessary conditions for constructing the A-CSBC for the augmented SHS.

5. CONSTRUCTION OF A-CSBC

In this section, we establish conditions on the SHS Φ_i that allow for the construction of an A-CSBC for $\mathcal{A}_i(\Phi_i)$. To do so, we first define a notion of control barrier certificates (CBC) over original Φ_i .

Definition 5.1. *Given an SHS Φ_i with initial and unsafe sets $X_{0_i}, X_{u_i} \subseteq X_i$, a function $\bar{\mathcal{B}}_i : X_i \rightarrow \mathbb{R}_0^+$ is called a control barrier certificate (CBC) for Φ_i if there exist $\gamma_{1_i} \in \mathbb{R}, \bar{\kappa}_i, \gamma_{2_i} \in \mathbb{R}^+, \bar{\mu}_i, \bar{\beta}_i, \bar{\varphi}_{i_1}, \bar{\varphi}_{i_2}, \bar{\eta}_{1_i}, \bar{\eta}_{2_i} \in \mathbb{R}_0^+$, such that*

$$\bar{\mathcal{B}}_i(x_i) \geq \bar{\kappa}_i \|x_i\|^2, \quad \forall x_i \in X_i, \quad (5.1a)$$

$$\bar{\mathcal{B}}_i(x_i) \leq \bar{\mu}_i, \quad \forall x_i \in X_{0_i}, \quad (5.1b)$$

$$\bar{\mathcal{B}}_i(x_i) \geq \bar{\beta}_i, \quad \forall x_i \in X_{u_i}, \quad (5.1c)$$

- $\forall x_i \in X_i, \exists \nu_i \in U_i$ such that $\forall w_i \in W_i$,

$$\mathcal{L}\bar{\mathcal{B}}_i(x_i) \leq -\gamma_{1_i}\bar{\mathcal{B}}_i(x_i) + \bar{\varphi}_{i_1}\|w_i\|^2 + \bar{\eta}_{1_i}, \quad (5.1d)$$

where $\mathcal{L}\bar{\mathcal{B}}_i(x_i)$ is the infinitesimal generator acting on $\bar{\mathcal{B}}_i(x_i)$, defined as [Oks13]

$$\mathcal{L}\bar{\mathcal{B}}_i(x_i) = \frac{\partial \bar{\mathcal{B}}_i(x_i)}{\partial x_i} f_{1_i}(x_i, \nu_i, w_i) + \frac{1}{2} \text{Tr}(\sigma_i(x_i) \sigma_i(x_i)^\top \frac{\partial^2 \bar{\mathcal{B}}_i(x_i)}{\partial x_i \partial x_j}) + \sum_{j=1}^{r_i} \lambda_{j_i} (\bar{\mathcal{B}}_i(x_i + \rho_i(x_i) \mathbf{e}_{j_i}^{r_i}) - \bar{\mathcal{B}}_i(x_i)),$$

where λ_j is the rate of Poisson processes and \mathbf{e}_j^r is an r -dimensional vector with 1 on the j -th entry and 0 elsewhere;

- $\forall x_i \in X_i, \exists \nu_i \in U_i$ such that $\forall w_i \in W_i$,

$$\mathbb{E} \left[\bar{\mathcal{B}}_i(f_{2_i}(x_i, \nu_i, w_i)) \mid x_i, \nu_i, w_i \right] \leq \gamma_{2_i} \bar{\mathcal{B}}_i(x_i) + \bar{\varphi}_{i_2} \|w_i\|^2 + \bar{\eta}_{2_i}. \quad (5.1e)$$

Before offering the main result of this section, we also raise the following lemma to quantify an upper bound on the evolution of CBC $\bar{\mathcal{B}}_i$.

Lemma 5.2. *Given an SHS $\Phi_i = (X_i, U_i, \mathcal{U}_i, W_i, \mathcal{W}_i, \sigma_i, \rho_i, f_{1_i}, \varsigma_i, f_{2_i})$, suppose (5.1d) holds. Then for any $x_i \in X_i, \nu_i \in \mathcal{U}_{\tau_i}, w_i \in W_i$, and for any two consecutive time instances (t_k, t_{k+1}) , one has*

$$\mathbb{E} \left[\bar{\mathcal{B}}_i(x_{x_i \nu_i w_i}(t_{k+1}^-)) \mid x_i, \nu_i, w_i \right] \leq e^{-\gamma_{1_i}(t_{k+1}-t_k)} \bar{\mathcal{B}}_i(x_{x_i \nu_i w_i}(t_k)) + e^{-\gamma_{1_i}(t_{k+1}-t_k)} (t_{k+1}-t_k) (\bar{\varphi}_{i_1} \|w_i\|_\infty^2 + \bar{\eta}_{1_i}). \quad (5.2)$$

Proof. From Dynkin's formula [Dyn65], we have:

$$\mathbb{E} \left[\bar{\mathcal{B}}_i(x_{x_i \nu_i w_i}(t_{k+1}^-)) \mid x_i, \nu_i, w_i \right] = \bar{\mathcal{B}}_i(x_{x_i \nu_i w_i}(t_k)) + \mathbb{E} \left[\int_{t_k}^{t_{k+1}} \mathcal{L}\bar{\mathcal{B}}_i(x_{x_i \nu_i w_i}(t)) dt \right].$$

From condition (5.1d), one has

$$\begin{aligned} \mathbb{E} \left[\bar{\mathcal{B}}_i(x_{x_i \nu_i w_i}(t_{k+1}^-) \mid x_i, \nu_i, w_i) \right] &\leq \bar{\mathcal{B}}_i(x_{x_i \nu_i w_i}(t_k)) + \mathbb{E} \left[\int_{t_k}^{t_{k+1}} (-\gamma_{1_i} \bar{\mathcal{B}}_i(x_{x_i \nu_i w_i}(t)) + \bar{\varphi}_{i_1} \|w_i\|^2 + \bar{\eta}_{1_i}) dt \right] \\ &= \bar{\mathcal{B}}_i(x_{x_i \nu_i w_i}(t_k)) + (t_{k+1} - t_k) (\bar{\varphi}_{i_1} \|w_i\|_\infty^2 + \bar{\eta}_{1_i}) - \int_{t_k}^{t_{k+1}} \gamma_{1_i} \mathbb{E} \left[\bar{\mathcal{B}}_i(x_{x_i \nu_i w_i}(t)) \right] dt. \end{aligned}$$

By employing Gronwall inequality [Gro19], we have

$$\mathbb{E} \left[\bar{\mathcal{B}}_i(x_{x_i \nu_i w_i}(t_{k+1}^-) \mid x_i, \nu_i, w_i) \right] \leq e^{-\gamma_{1_i}(t_{k+1} - t_k)} \bar{\mathcal{B}}_i(x_{x_i \nu_i w_i}(t_k)) + e^{-\gamma_{1_i}(t_{k+1} - t_k)} (t_{k+1} - t_k) (\bar{\varphi}_{i_1} \|w_i\|_\infty^2 + \bar{\eta}_{1_i}),$$

which concludes the proof. \blacksquare

Under Definition 5.1 and Lemma 5.2, we propose the next theorem to construct an A-CSBC for $\mathcal{A}_i(\Phi_i)$ based on the CBC $\bar{\mathcal{B}}_i$.

Theorem 5.3. *Given an SHS $\Phi_i = (X_i, U_i, \mathcal{U}_i, W_i, \mathcal{W}_i, \sigma_i, \rho_i, f_{1_i}, \varsigma_i, f_{2_i})$ with its associated A-SHS $\mathcal{A}_i(\Phi_i) = (\mathbb{X}_i, \mathbb{U}_i, \mathbb{W}_i, \sigma_i, \rho_i, \varsigma_i, \mathbb{F}_i, \mathbb{Y}_i, \mathbb{H}_i)$, suppose $\bar{\mathcal{B}}_i$ is a CBC for Φ_i . If*

$$\ln(\gamma_{2_i}) - \gamma_{1_i} \tau \vartheta_i < 0, \quad \forall \vartheta_i \in \{\varepsilon_{1_i}, \dots, \varepsilon_{2_i}\}, \quad (5.3)$$

then

$$\mathcal{B}_i(x_i, \vartheta_i) = \varpi_i \bar{\mathcal{B}}_i(x_i) \quad (5.4)$$

is an A-CSBC for $\mathcal{A}_i(\Phi_i)$ with

$$\varpi_i := \begin{cases} 1, & \text{if } \gamma_{1_i} > 0 \text{ \& } 0 < \gamma_{2_i} < 1, \\ e^{\gamma_{1_i} \tau \alpha_{1_i} \vartheta_i}, & \text{if } \gamma_{1_i} > 0 \text{ \& } \gamma_{2_i} \geq 1, \\ \frac{\vartheta_i}{\gamma_{2_i}^{\alpha_{2_i}}}, & \text{if } \gamma_{1_i} \leq 0 \text{ \& } 0 < \gamma_{2_i} < 1, \end{cases} \quad (5.5)$$

for some $0 < \alpha_{1_i} < 1$ and $\alpha_{2_i} > \varepsilon_{2_i}$.

Proof. By employing (5.1a), for any $(x_i, \vartheta_i) \in \mathbb{X}_i$, one has

$$\mathcal{B}_i(x_i, \vartheta_i) = \varpi_i \bar{\mathcal{B}}_i(x_i) \geq \varpi_i \bar{\kappa}_i \|x_i\|^2.$$

Then condition (3.1a) holds with $\kappa_i = \varpi_i \bar{\kappa}_i$. By leveraging (5.1b), for any $(x_i, \vartheta_i) \in \mathbb{X}_{0_i}$, one has

$$\mathcal{B}_i(x_i, \vartheta_i) = \varpi_i \bar{\mathcal{B}}_i(x_i) \leq \varpi_i \bar{\mu}_i,$$

and similarly by utilizing (5.1c) for any $(x_i, \vartheta_i) \in \mathbb{X}_{u_i}$, one has

$$\mathcal{B}_i(x_i, \vartheta_i) = \varpi_i \bar{\mathcal{B}}_i(x_i) \geq \varpi_i \bar{\beta}_i,$$

satisfying conditions (3.1b) and (3.1c) with $\mu_i = \varpi_i \bar{\mu}_i$ and $\beta_i = \varpi_i \bar{\beta}_i$.

Now we proceed with showing condition (3.1d), as well. From (5.2) with $t_{k+1} = \tau, t_k = 0$, one gets

$$\begin{aligned} \mathbb{E} \left[\bar{\mathcal{B}}_i(x_{x_i \nu_i w_i}(t_{k+1}^-) \mid x_i, \nu_i, w_i) \right] &\leq e^{-\gamma_{1_i} \tau} (\bar{\mathcal{B}}_i(x_{x_i \nu_i w_i}(0)) + \tau(\bar{\varphi}_{i_1} \|w_i\|_\infty^2 + \bar{\eta}_{1_i})) \\ &= e^{-\gamma_{1_i} \tau} \bar{\mathcal{B}}_i(x_i) + e^{-\gamma_{1_i} \tau} \tau \bar{\varphi}_{i_1} \|w_i\|_\infty^2 + e^{-\gamma_{1_i} \tau} \tau \bar{\eta}_{1_i}. \end{aligned}$$

In order to show that \mathcal{B}_i defined in (5.4) fulfills condition (3.1d), we consider the two cases in Definition 2.3 and the three bounds for different values of γ_{1_i} and γ_{2_i} in (5.5) as follows:

- **Bound 1** ($\gamma_{1_i} > 0$ & $0 < \gamma_{2_i} < 1$):
 - (i) **Flow case** ($0 \leq \vartheta_i \leq \varepsilon_{2_i} - 1, \vartheta'_i = \vartheta_i + 1$):

$$\begin{aligned} \mathbb{E} \left[\mathcal{B}_i(x'_i, \vartheta'_i) \mid x_i, \nu_i, w_i, \vartheta_i \right] &= \mathbb{E} \left[\bar{\mathcal{B}}_i(x'_i) \mid x_i, \nu_i, w_i \right] \\ &\leq e^{-\gamma_{1_i} \tau} \bar{\mathcal{B}}_i(x_i) + e^{-\gamma_{1_i} \tau} \tau \bar{\varphi}_{i_1} \|w_i\|_\infty^2 + e^{-\gamma_{1_i} \tau} \tau \bar{\eta}_{1_i} \\ &= e^{-\gamma_{1_i} \tau} \mathcal{B}_i(x_i, \vartheta_i) + e^{-\gamma_{1_i} \tau} \tau \bar{\varphi}_{i_1} \|w_i\|_\infty^2 + e^{-\gamma_{1_i} \tau} \tau \bar{\eta}_{1_i} \\ &\leq e^{-\gamma_{1_i} \tau} \mathcal{B}_i(x_i, \vartheta_i) + e^{-\gamma_{1_i} \tau} \tau \bar{\varphi}_{i_1} (\|w_i\|_\infty^2 + \|w_i\|^2) + e^{-\gamma_{1_i} \tau} \tau \bar{\eta}_{1_i} \\ &= e^{-\gamma_{1_i} \tau} \mathcal{B}_i(x_i, \vartheta_i) + e^{-\gamma_{1_i} \tau} \tau \bar{\varphi}_{i_1} \|w_i\|^2 + e^{-\gamma_{1_i} \tau} \tau \bar{\varphi}_{i_1} \|w_i\|_\infty^2 + e^{-\gamma_{1_i} \tau} \tau \bar{\eta}_{1_i}. \end{aligned}$$

- (ii) **Jump case** ($\varepsilon_{1_i} \leq \vartheta_i \leq \varepsilon_{2_i}, \vartheta'_i = 0$):

$$\begin{aligned} \mathbb{E} \left[\mathcal{B}_i(x'_i, \vartheta'_i) \mid x_i, \nu_i, w_i, \vartheta_i \right] &= \mathbb{E} \left[\bar{\mathcal{B}}_i(x'_i) \mid x_i, \nu_i, w_i \right] \\ &\leq \gamma_{2_i} \bar{\mathcal{B}}_i(x_i) + \bar{\varphi}_{i_1} \|w_i\|^2 + \bar{\eta}_{2_i} = \gamma_{2_i} \mathcal{B}_i(x_i, \vartheta_i) + \bar{\varphi}_{i_2} \|w_i\|^2 + \bar{\eta}_{2_i}. \end{aligned}$$

By defining $\gamma_i = \max\{e^{-\gamma_{1_i} \tau}, \gamma_{2_i}\}$, $\varphi_i = \max\{e^{-\gamma_{1_i} \tau} \tau \bar{\varphi}_{i_1}, \bar{\varphi}_{i_2}\}$ and $\eta_i = \max\{e^{-\gamma_{1_i} \tau} \tau \bar{\varphi}_{i_1} \|w_i\|_\infty^2 + e^{-\gamma_{1_i} \tau} \tau \bar{\eta}_{1_i}, \bar{\eta}_{2_i}\}$, we have

$$\mathbb{E} \left[\mathcal{B}_i(x'_i, \vartheta'_i) \mid x_i, \nu_i, w_i, \vartheta_i \right] \leq \gamma_i \mathcal{B}_i(x_i, \vartheta_i) + \varphi_i \|w_i\|^2 + \eta_i.$$

- **Bound 2** ($\gamma_{1_i} > 0$ & $\gamma_{2_i} \geq 1$):

(i) **Flow case** ($0 \leq \vartheta_i \leq \varepsilon_{2_i} - 1, \vartheta'_i = \vartheta_i + 1$):

$$\begin{aligned}
& \mathbb{E} \left[\mathcal{B}_i(x'_i, \vartheta'_i) \mid x_i, \nu_i, w_i, \vartheta_i \right] \\
&= e^{\gamma_{1_i} \tau \alpha_{1_i} \vartheta'_i} \mathbb{E} \left[\bar{\mathcal{B}}_i(x'_i) \mid x_i, \nu_i, w_i \right] \\
&= e^{\gamma_{1_i} \tau \alpha_{1_i} (\vartheta_i + 1)} \mathbb{E} \left[\bar{\mathcal{B}}_i(x'_i) \mid x_i, \nu_i, w_i \right] \\
&\leq e^{\gamma_{1_i} \tau \alpha_{1_i} (\vartheta_i + 1)} \left(e^{-\gamma_{1_i} \tau} \bar{\mathcal{B}}_i(x_i) + e^{-\gamma_{1_i} \tau} \tau \bar{\varphi}_{i_1} \|w_i\|_\infty^2 + e^{-\gamma_{1_i} \tau} \tau \bar{\eta}_{1_i} \right) \\
&= e^{-\gamma_{1_i} \tau} e^{\gamma_{1_i} \tau \alpha_{1_i}} e^{\gamma_{1_i} \tau \alpha_{1_i} \vartheta_i} \bar{\mathcal{B}}_i(x_i) + e^{\gamma_{1_i} \tau \alpha_{1_i} (\vartheta_i + 1)} e^{-\gamma_{1_i} \tau} \tau \bar{\varphi}_{i_1} \|w_i\|_\infty^2 + e^{\gamma_{1_i} \tau \alpha_{1_i} (\vartheta_i + 1)} e^{-\gamma_{1_i} \tau} \tau \bar{\eta}_{1_i} \\
&= e^{-\gamma_{1_i} \tau (1 - \alpha_{1_i})} \mathcal{B}_i(x_i, \vartheta_i) + e^{\gamma_{1_i} \tau \alpha_{1_i} (\vartheta_i + 1)} e^{-\gamma_{1_i} \tau} \tau \bar{\varphi}_{i_1} \|w_i\|_\infty^2 + e^{\gamma_{1_i} \tau \alpha_{1_i} (\vartheta_i + 1)} e^{-\gamma_{1_i} \tau} \tau \bar{\eta}_{1_i} \\
&\leq e^{-\gamma_{1_i} \tau (1 - \alpha_{1_i})} \mathcal{B}_i(x_i, \vartheta_i) + e^{\gamma_{1_i} \tau \alpha_{1_i} \varepsilon_{2_i}} e^{-\gamma_{1_i} \tau} \tau \bar{\varphi}_{i_1} \|w_i\|_\infty^2 + e^{\gamma_{1_i} \tau \alpha_{1_i} \varepsilon_{2_i}} e^{-\gamma_{1_i} \tau} \tau \bar{\eta}_{1_i} \\
&\leq e^{-\gamma_{1_i} \tau (1 - \alpha_{1_i})} \mathcal{B}_i(x_i, \vartheta_i) + e^{\gamma_{1_i} \tau \alpha_{1_i} \varepsilon_{2_i}} e^{-\gamma_{1_i} \tau} \tau \bar{\varphi}_{i_1} (\|w_i\|_\infty^2 + \|w_i\|^2) + e^{\gamma_{1_i} \tau \alpha_{1_i} \varepsilon_{2_i}} e^{-\gamma_{1_i} \tau} \tau \bar{\eta}_{1_i} \\
&= e^{-\gamma_{1_i} \tau (1 - \alpha_{1_i})} \mathcal{B}_i(x_i, \vartheta_i) + e^{\gamma_{1_i} \tau \alpha_{1_i} \varepsilon_{2_i}} e^{-\gamma_{1_i} \tau} \tau \bar{\varphi}_{i_1} \|w_i\|^2 + e^{\gamma_{1_i} \tau \alpha_{1_i} \varepsilon_{2_i}} e^{-\gamma_{1_i} \tau} \tau \bar{\varphi}_{i_1} \|w_i\|_\infty^2 \\
&\quad + e^{\gamma_{1_i} \tau \alpha_{1_i} \varepsilon_{2_i}} e^{-\gamma_{1_i} \tau} \tau \bar{\eta}_{1_i}.
\end{aligned}$$

(ii) **Jump case** ($\varepsilon_{1_i} \leq \vartheta_i \leq \varepsilon_{2_i}, \vartheta'_i = 0$):

$$\begin{aligned}
\mathbb{E} \left[\mathcal{B}_i(x'_i, \vartheta'_i) \mid x_i, \nu_i, w_i, \vartheta_i \right] &= e^{\gamma_{1_i} \tau \alpha_{1_i} \vartheta'_i} \mathbb{E} \left[\bar{\mathcal{B}}_i(x'_i) \mid x_i, \nu_i, w_i \right] \\
&= \mathbb{E} \left[\bar{\mathcal{B}}_i(x'_i) \mid x_i, \nu_i, w_i \right] \\
&\leq \gamma_{2_i} \bar{\mathcal{B}}_i(x_i) + \bar{\varphi}_{i_2} \|w_i\|^2 + \bar{\eta}_{2_i} \\
&= \frac{e^{\gamma_{1_i} \tau \alpha_{1_i} \vartheta_i}}{e^{\gamma_{1_i} \tau \alpha_{1_i} \vartheta_i}} \gamma_{2_i} \bar{\mathcal{B}}_i(x_i) + \bar{\varphi}_{i_2} \|w_i\|^2 + \bar{\eta}_{2_i} \\
&\leq e^{-\gamma_{1_i} \tau \alpha_{1_i} \varepsilon_{1_i}} \gamma_{2_i} \mathcal{B}_i(x_i, \vartheta_i) + \bar{\varphi}_{i_2} \|w_i\|^2 + \bar{\eta}_{2_i}.
\end{aligned}$$

By defining

$$\gamma_i = \max\{e^{-\gamma_{1_i} \tau (1 - \alpha_{1_i})}, e^{-\gamma_{1_i} \tau \alpha_{1_i} \varepsilon_{1_i}} \gamma_{2_i}\}, \quad \varphi_i = \max\{e^{\gamma_{1_i} \tau \alpha_{1_i} \varepsilon_{2_i}} e^{-\gamma_{1_i} \tau} \tau \bar{\varphi}_{i_1}, \bar{\varphi}_{i_2}\},$$

and

$$\eta_i = \max\{e^{\gamma_{1_i} \tau \alpha_{1_i} \varepsilon_{2_i}} e^{-\gamma_{1_i} \tau} \tau \bar{\varphi}_{i_1} \|w_i\|_\infty^2 + e^{\gamma_{1_i} \tau \alpha_{1_i} \varepsilon_{2_i}} e^{-\gamma_{1_i} \tau} \tau \bar{\eta}_{1_i}, \bar{\eta}_{2_i}\},$$

we have

$$\mathbb{E} \left[\mathcal{B}_i(x'_i, \vartheta'_i) \mid x_i, \nu_i, w_i, \vartheta_i \right] \leq \gamma_i \mathcal{B}_i(x_i, \vartheta_i) + \varphi_i \|w_i\|^2 + \eta_i.$$

• **Bound 3** ($\gamma_{1_i} \leq 0$ & $0 < \gamma_{2_i} < 1$):

(i) **Flow case** ($0 \leq \vartheta_i \leq \varepsilon_{2_i} - 1, \vartheta'_i = \vartheta_i + 1$):

$$\begin{aligned}
& \mathbb{E} \left[\mathcal{B}_i(x'_i, \vartheta'_i) \mid x_i, \nu_i, w_i, \vartheta_i \right] \\
&= \gamma_{2_i}^{\frac{\vartheta'_i}{\alpha_{2_i}}} \mathbb{E} \left[\bar{\mathcal{B}}_i(x'_i) \mid x_i, \nu_i, w_i \right] \\
&= \gamma_{2_i}^{\frac{\vartheta_i+1}{\alpha_{2_i}}} \mathbb{E} \left[\bar{\mathcal{B}}_i(x'_i) \mid x_i, \nu_i, w_i \right] \\
&\leq \gamma_{2_i}^{\frac{\vartheta_i+1}{\alpha_{2_i}}} \left(e^{-\gamma_i \tau} \bar{\mathcal{B}}_i(x_i) + e^{-\gamma_i \tau} \tau \bar{\varphi}_{i_1} \|w_i\|_\infty^2 + e^{-\gamma_i \tau} \tau \bar{\eta}_{1_i} \right) \\
&= e^{-\gamma_i \tau} \gamma_{2_i}^{\frac{1}{\alpha_{2_i}}} \gamma_{2_i}^{\frac{\vartheta_i}{\alpha_{2_i}}} \bar{\mathcal{B}}_i(x_i) + \gamma_{2_i}^{\frac{\vartheta_i+1}{\alpha_{2_i}}} e^{-\gamma_i \tau} \tau \bar{\varphi}_{i_1} \|w_i\|_\infty^2 + \gamma_{2_i}^{\frac{\vartheta_i+1}{\alpha_{2_i}}} e^{-\gamma_i \tau} \tau \bar{\eta}_{1_i} \\
&\leq e^{-\gamma_i \tau} \gamma_{2_i}^{\frac{1}{\alpha_{2_i}}} \mathcal{B}_i(x_i, \vartheta_i) + \gamma_{2_i}^{\frac{1}{\alpha_{2_i}}} e^{-\gamma_i \tau} \tau \bar{\varphi}_{i_1} \|w_i\|_\infty^2 + \gamma_{2_i}^{\frac{1}{\alpha_{2_i}}} e^{-\gamma_i \tau} \tau \bar{\eta}_{1_i} \\
&\leq e^{-\gamma_i \tau} \gamma_{2_i}^{\frac{1}{\alpha_{2_i}}} \mathcal{B}_i(x_i, \vartheta_i) + \gamma_{2_i}^{\frac{1}{\alpha_{2_i}}} e^{-\gamma_i \tau} \tau \bar{\varphi}_{i_1} (\|w_i\|_\infty^2 + \|w_i\|^2) + \gamma_{2_i}^{\frac{1}{\alpha_{2_i}}} e^{-\gamma_i \tau} \tau \bar{\eta}_{1_i} \\
&= e^{-\gamma_i \tau} \gamma_{2_i}^{\frac{1}{\alpha_{2_i}}} \mathcal{B}_i(x_i, \vartheta_i) + \gamma_{2_i}^{\frac{1}{\alpha_{2_i}}} e^{-\gamma_i \tau} \tau \bar{\varphi}_{i_1} \|w_i\|^2 + \gamma_{2_i}^{\frac{1}{\alpha_{2_i}}} e^{-\gamma_i \tau} \tau \bar{\varphi}_{i_1} \|w_i\|_\infty^2 + \gamma_{2_i}^{\frac{1}{\alpha_{2_i}}} e^{-\gamma_i \tau} \tau \bar{\eta}_{1_i}.
\end{aligned}$$

(ii) **Jump case** ($\varepsilon_{1_i} \leq \vartheta_i \leq \varepsilon_{2_i}, \vartheta'_i = 0$):

$$\begin{aligned}
\mathbb{E} \left[\mathcal{B}_i(x'_i, \vartheta'_i) \mid x_i, \nu_i, w_i, \vartheta_i \right] &= \gamma_{2_i}^{\frac{\vartheta'_i}{\alpha_{2_i}}} \mathbb{E} \left[\bar{\mathcal{B}}_i(x'_i) \mid x_i, \nu_i, w_i \right] \\
&= \mathbb{E} \left[\bar{\mathcal{B}}_i(x'_i) \mid x_i, \nu_i, w_i \right] \leq \gamma_{2_i} \bar{\mathcal{B}}_i(x_i) + \bar{\varphi}_{i_2} \|w_i\|^2 + \bar{\eta}_{2_i} \\
&= \frac{\gamma_{2_i}^{\frac{\vartheta_i}{\alpha_{2_i}}}}{\gamma_{2_i}^{\frac{\vartheta_i}{\alpha_{2_i}}}} \gamma_{2_i} \bar{\mathcal{B}}_i(x_i) + \bar{\varphi}_{i_2} \|w_i\|^2 + \bar{\eta}_{2_i} \\
&\leq \gamma_{2_i}^{\frac{\alpha_{2_i} - \varepsilon_{2_i}}{\alpha_{2_i}}} \mathcal{B}_i(x_i, \vartheta_i) + \bar{\varphi}_{i_2} \|w_i\|^2 + \bar{\eta}_{2_i}.
\end{aligned}$$

By defining

$$\gamma_i = \max \left\{ e^{-\gamma_i \tau} \gamma_{2_i}^{\frac{1}{\alpha_{2_i}}}, \gamma_{2_i}^{\frac{\alpha_{2_i} - \varepsilon_{2_i}}{\alpha_{2_i}}} \right\}, \quad \varphi_i = \max \left\{ \gamma_{2_i}^{\frac{1}{\alpha_{2_i}}} e^{-\gamma_i \tau} \tau \bar{\varphi}_{i_1}, \bar{\varphi}_{i_2} \right\},$$

and

$$\eta_i = \max \left\{ \gamma_{2_i}^{\frac{1}{\alpha_{2_i}}} e^{-\gamma_i \tau} \tau \bar{\varphi}_{i_1} \|w_i\|_\infty^2 + \gamma_{2_i}^{\frac{1}{\alpha_{2_i}}} e^{-\gamma_i \tau} \tau \bar{\eta}_{1_i}, \bar{\eta}_{2_i} \right\},$$

we have

$$\mathbb{E} \left[\mathcal{B}_i(x'_i, \vartheta'_i) \mid x_i, \nu_i, w_i, \vartheta_i \right] \leq \gamma_i \mathcal{B}_i(x_i, \vartheta_i) + \varphi_i \|w_i\|^2 + \eta_i.$$

To complete the proof, we proceed with showing that $0 < \gamma_i < 1$ for all Bounds 1-3. One can readily verify that

$$0 < \gamma_i = \max \{ e^{-\gamma_i \tau}, \gamma_{2_i} \} < 1,$$

for Bound 1. In Bound 2, since $0 < \alpha_{1_i} < 1$ and $\gamma_{1_i} > 0$, then we have $e^{-\gamma_{1_i}\tau(1-\alpha_{1_i})} < 1$. In addition,

$$e^{-\gamma_{1_i}\tau\alpha_{1_i}\varepsilon_{1_i}}\gamma_{2_i} < 1 \Leftrightarrow \ln(\gamma_{2_i}) - \gamma_{1_i}\tau\alpha_{1_i}\varepsilon_{1_i} < 0.$$

Since $\ln(\gamma_{2_i}) - \gamma_{1_i}\tau\vartheta_i < 0$ for any $\vartheta_i \in \{\varepsilon_{1_i}, \dots, \varepsilon_{2_i}\}$ and by leveraging the continuity property of real numbers, one can always find some $0 < \alpha_{1_i} < 1$ such that $\ln(\gamma_{2_i}) - \gamma_{1_i}\tau\alpha_{1_i}\varepsilon_{1_i} < 0$. Hence, $0 < \gamma_i < 1$. Similarly, in Bound 3, one has $\gamma_{2_i}^{\frac{\alpha_{2_i} - \varepsilon_{2_i}}{\alpha_{2_i}}} < 1$ since $\alpha_{2_i} > \varepsilon_{2_i}$ and $0 < \gamma_{2_i} < 1$. Additionally,

$$e^{-\gamma_{1_i}\tau\gamma_{2_i}^{\frac{1}{\alpha_{2_i}}}} < 1 \Leftrightarrow \ln(\gamma_{2_i}) - \gamma_{1_i}\tau\alpha_{2_i} < 0.$$

Since $\ln(\gamma_{2_i}) - \gamma_{1_i}\tau\vartheta_i < 0$ for any $\vartheta_i \in \{\varepsilon_{1_i}, \dots, \varepsilon_{2_i}\}$ and $\alpha_{2_i} > \varepsilon_{2_i}$, then $\ln(\gamma_{2_i}) - \gamma_{1_i}\tau\alpha_{2_i} < 0$. Consequently, $0 < \gamma_i < 1$. Hence, \mathcal{B}_i as in (5.4) is an A-CBC for $\mathcal{A}_i(\Phi_i)$, which completes the proof. \blacksquare

6. COMPUTATION OF CBC

Here, we employ sum-of-squares (SOS) optimization techniques [Par03] and search for a CBC and its corresponding controller for each Φ_i . To do so, we assume that f_{1_i} and f_{2_i} are polynomial functions. The next lemma provides the SOS formulation.

Lemma 6.1. *Suppose sets $X_{0_i}, X_{u_i}, X_i, U_i$, and W_i can be described by $X_{0_i} = \{x_i \in \mathbb{R}^{n_i} \mid g_{0_i}(x_i) \geq 0\}$, $X_{u_i} = \{x_i \in \mathbb{R}^{n_i} \mid g_{u_i}(x_i) \geq 0\}$, $X_i = \{x_i \in \mathbb{R}^{n_i} \mid g_i(x_i) \geq 0\}$, $U_i = \{U_i \subseteq \mathbb{R}^{m_i} \mid g_{\nu_i}(\nu_i) \geq 0\}$, and $W_i = \{W_i \subseteq \mathbb{R}^{p_i} \mid g_{w_i}(w_i) \geq 0\}$. Let there exist an SOS polynomial $\bar{\mathcal{B}}_i(x_i)$, constants $\gamma_{1_i} \in \mathbb{R}$, $\bar{\kappa}_i, \gamma_{2_i} \in \mathbb{R}^+$, $\bar{\mu}_i, \bar{\beta}_i, \bar{\varphi}_{i_1}, \bar{\varphi}_{i_2}, \bar{\eta}_{1_i}, \bar{\eta}_{2_i} \in \mathbb{R}_0^+$, polynomials $l_{\nu_{j_i}}(x_i), \hat{l}_{\nu_{j_i}}(x_i)$ corresponding to the j^{th} input in $\nu_i = (\nu_{1_i}, \nu_{2_i}, \dots, \nu_{m_i}) \in U_i \subseteq \mathbb{R}^{m_i}$ and $\bar{\nu}_i = (\bar{\nu}_{1_i}, \bar{\nu}_{2_i}, \dots, \bar{\nu}_{m_i}) \in U_i \subseteq \mathbb{R}^{m_i}$, respectively. Suppose there exist vectors of SOS polynomials $l_{0_i}(x_i), l_{u_i}(x_i), \tilde{l}_i(x_i), l_i(x_i, \nu_i, w_i), \hat{l}_i(x_i, \nu_i, w_i), l_{\nu_i}(x_i, \nu_i, w_i), \hat{l}_{\nu_i}(x_i, \nu_i, w_i), l_{w_i}(x_i, \nu_i, w_i), \hat{l}_{w_i}(x_i, \nu_i, w_i)$ of appropriate dimensions such that the following expressions are SOS polynomials:*

$$\bar{\mathcal{B}}_i(x_i) - \tilde{l}_i^\top(x_i)g_i(x_i) - \bar{\kappa}_i x_i^\top x_i, \quad (6.1a)$$

$$-\bar{\mathcal{B}}_i(x_i) - l_{0_i}^\top(x_i)g_{0_i}(x_i) + \bar{\mu}_i, \quad (6.1b)$$

$$\bar{\mathcal{B}}_i(x_i) - l_{u_i}^\top(x_i)g_{u_i}(x_i) - \bar{\beta}_i, \quad (6.1c)$$

$$\begin{aligned} & -\mathcal{L}\bar{\mathcal{B}}_i(x_i) - \gamma_{1_i}(\bar{\mathcal{B}}_i(x_i)) + \bar{\varphi}_{i_1} w_i^\top w_i + \bar{\eta}_{1_i} \sum_{j=1}^{m_i} (\nu_{j_i} - l_{\nu_{j_i}}(x_i)) - l_i^\top(x_i, \nu_i, w_i)g_i(x_i) \\ & - l_{\nu_i}^\top(x_i, \nu_i, w_i)g_{\nu_i}(\nu_i) - l_{w_i}^\top(x_i, \nu_i, w_i)g_{w_i}(w_i), \end{aligned} \quad (6.1d)$$

$$\begin{aligned} & -\mathbb{E}\left[\bar{\mathcal{B}}_i(f_{2_i}(x_i, \nu_i, w_i)) \mid x_i, \nu_i, w_i\right] + \gamma_{2_i}\bar{\mathcal{B}}_i(x_i) + \bar{\varphi}_{i_2} w_i^\top w_i + \bar{\eta}_{2_i} - \sum_{j=1}^{m_i} (\nu_{j_i} - \hat{l}_{\nu_{j_i}}(x_i)) \\ & - \hat{l}_i^\top(x_i, \nu_i, w_i)g_i(x_i) - \hat{l}_{\nu_i}^\top(x_i, \nu_i, w_i)g_{\nu_i}(\nu_i) - \hat{l}_{w_i}^\top(x_i, \nu_i, w_i)g_{w_i}(w_i). \end{aligned} \quad (6.1e)$$

Then $\bar{\mathcal{B}}_i(x_i)$ fulfills conditions (5.1a)-(5.1e) in Definition 5.1. Furthermore, $\nu_i = [l_{\nu_{1_i}}(x_i); \dots; l_{\nu_{m_i}}(x_i)]$ and $\hat{\nu}_i = [\hat{l}_{\nu_{1_i}}(x_i); \dots; \hat{l}_{\nu_{m_i}}(x_i)]$ are corresponding controllers in flow and jump cases, respectively.

Proof. Since $\bar{\mathcal{B}}_i(x_i) - \tilde{l}_i^\top(x_i)g_i(x_i) - \bar{\kappa}_i x_i^\top x_i$ is SOS and the term $\tilde{l}_i^\top(x_i)g_i(x_i)$ is non-negative over X_i , the new condition (6.1a) implies condition (5.1a) in Definition 5.1. Similarly, we can show that conditions (6.1b),(6.1c) imply (5.1b),(5.1c), respectively. Now we show that condition (6.1d) implies (5.1d), as well. By selecting inputs $\nu_{j_i} = l_{\nu_{j_i}}(x_i)$ and since $\bar{l}_i^\top(x_i, \nu_i, w_i)g_i(x_i)$, $\bar{l}_{\nu_i}^\top(x_i, \nu_i, w_i)g_{\nu_i}(w_i)$, and $\bar{l}_{w_i}^\top(x_i, \nu_i, w_i)g_{w_i}(w_i)$ are all non-negative, we have

$$\mathcal{L}\bar{\mathcal{B}}_i(x_i) \leq -\gamma_{1_i}\bar{\mathcal{B}}_i(x_i) + \bar{\varphi}_{i_1}\|w_i\|^2 + \bar{\eta}_{1_i}.$$

Similarly, one can also show that the new condition (6.1e) implies condition (5.1e) in Definition 5.1. Hence $\bar{\mathcal{B}}_i$ is a CBC, which concludes the proof. \blacksquare

Remark 6.2. The computational complexity of SOS is influenced by both the polynomial degree of CBC and the dimensionality of the state variables. Existing research indicates that when the degree of CBC is fixed, the computational demands increase polynomially as the network dimension grows [WTL15]. In contrast, our compositional data-driven approach significantly reduces this complexity, scaling linearly with the number of subsystems.

7. CASE STUDY

Here, we demonstrate the effectiveness of our proposed results by applying them to an interconnected stochastic hybrid system composed of 1000 nonlinear subsystems. The model of the interconnected SHS Φ is given as

$$\Phi: \begin{cases} dx(t) = (A_1 x^{\circ 3}(t) + B_1 \nu(t))dt + E d\mathbb{W}_t + F d\mathbb{P}_t, & t \in \mathbb{R}_0^+ \setminus \Delta, \\ x(t) = A_2 x^{\circ 3}(t^-) + B_2 \nu(t) + G \zeta(t), & t \in \Delta, \end{cases} \quad (7.1)$$

where A_1, A_2 are matrices with diagonal elements $\bar{a}_{1_{ii}} = a_1, \bar{a}_{2_{ii}} = a_2$, off-diagonal elements $\bar{a}_{1_{i,i+1}} = \bar{a}_{1_{i+1,i}} = \bar{a}_{1_{1,N}} = \bar{a}_{1_{N,1}} = d_1, \bar{a}_{2_{i,i+1}} = \bar{a}_{2_{i+1,i}} = \bar{a}_{2_{1,N}} = \bar{a}_{2_{N,1}} = d_2, i \in \{2, \dots, N-1\}$, and all other elements are identically zero. Moreover, $B_1 = \text{diag}(b_1), B_2 = \text{diag}(b_2), E = 0.6\mathbb{I}_N, F = 0.5\mathbb{I}_N, G = 0.5\mathbb{I}_N, x = [x_1; \dots; x_N], \nu(t) = [\nu_1(t); \dots; \nu_n(t)]$. Now by considering individual subsystems as Φ_i as

$$\Phi_i: \begin{cases} dx_i(t) = (a_1 x_i^3(t) + b_1 \nu_i(t) + d_1 w_i(t))dt + 0.6d\mathbb{W}_t + 0.5d\mathbb{P}_t, & t \in \mathbb{R}_0^+ \setminus \Delta_i, \\ x_i(t) = a_2 x_i^3(t^-) + b_2 \nu_i(t) + d_2 w_i(t) + 0.5\zeta_i(t), & t \in \Delta_i, \end{cases} \quad (7.2)$$

with $a_1, b_1, a_2, b_2 \in \mathbb{R}$, jump parameters $\tau = 0.1, \varepsilon_{1_i} = 1, \varepsilon_{2_i} = 7$, and rates of Poisson processes as $\lambda_i = 0.5$, one can readily verify that $\Phi = \mathcal{I}(\Phi_1, \dots, \Phi_N)$ where $w_i(t) = x_{i\pm 1}(t)$ (with $x_0 = x_N$ and $x_{N+1} = x_1$), i.e., circular interconnection topology.

The regions of interest are given as $X \in [0, 8]^{1000}$, $X_0 \in [0, 1.5]^{1000}$, $X_u = [7, 8]^{1000}$. The main goal is to design an A-CBC for the interconnected A-SHS and its corresponding safety controllers based on A-CSBCs of individual subsystems such that the state of the system remains in the comfort zone $[0, 7]^{1000}$. To do so, we first search for CBCs and accordingly design local controllers for Φ_i . Consequently, A-CSBCs can be constructed from CBCs according to Theorem 5.3. We show our results for different values of a_1, b_1, a_2, b_2 .

We employ the toolbox SOSTOOLS [PAV⁺13] and the SDP solver SeDuMi [Stu99] to compute CBC as described in Section 6. For $a_1 = -0.4, b_1 = 0.5, a_2 = 0.01, b_2 = 0.06$, based on Lemma 6.1, we compute a CBC of an order 4 as $\bar{\mathcal{B}}_i(x_i) = 0.0049x_i^4 - 0.0311x_i^3 + 0.0721x_i^2 - 0.0734x_i + 0.0557$ and corresponding controllers $\nu_i = -0.05152x_i + 3$ and $\hat{\nu}_i = -0.06145x_i + 2.6$ for flow and jump cases, respectively. Moreover, the corresponding constants in Definition 5.1 satisfying conditions (5.1a)-(5.1e) are quantified as $\bar{\mu}_i = 0.13, \bar{\beta}_i = 4.4, \bar{\kappa}_i = 0.005, \bar{\eta}_{1_i} = 0.0015, \bar{\eta}_{2_i} = 0.0012, \bar{\varphi}_{1_i} = 0.00001, \bar{\varphi}_{2_i} = 0.00001, \gamma_{1_i} = 0.01, \gamma_{2_i} = 0.99$. We now proceed with Theorem 5.3 to construct an A-CSBC for the augmented system using the obtained CBC. We select $\alpha_{1_i} = 0.1, \alpha_{2_i} = 8$. Since $\gamma_{1_i} = 0.01 > 0$ and $0 < \gamma_{2_i} = 0.99 < 1$, the results of Bound 1 are useful. One can readily verify that condition (5.3) is also met for all $\vartheta_i \in \{\varepsilon_{1_i}, \dots, \varepsilon_{2_i}\}$. Then one can conclude that $\mathcal{B}_i(x_i, \vartheta_i) := \bar{\mathcal{B}}_i(x_i)$ is a CSBC for the augmented SHS with $\gamma_i = \max\{e^{-\gamma_{1_i}\tau}, \gamma_{2_i}\} = 0.99, \varphi_i = \max\{e^{-\gamma_{1_i}\tau}\bar{\varphi}_{1_i}, \bar{\varphi}_{2_i}\} = 0.00001$ and $\eta_i = \max\{e^{-\gamma_{1_i}\tau}\bar{\varphi}_{1_i}\|w_i\|_\infty^2 + e^{-\gamma_{1_i}\tau}\bar{\eta}_{1_i}, \bar{\eta}_{2_i}\} = 0.0012$. We now proceed to construct an A-CBC based on A-CSBCs of individual subsystems according to compositionality Theorem 4.2. By selecting $\xi_i = 0.001, \forall i \in \{1, \dots, 1000\}$, one has $\xi_i\Gamma_i = -6 \times 10^{-6} < 0$, implying the satisfaction of condition (4.1a). Moreover, we compute $\beta = \sum_{i=1}^{1000} \xi_i\beta_i = 4.4$, and $\mu = \sum_{i=1}^{1000} \xi_i\mu_i = 0.13$, that imply condition (4.1b). Then, it can be concluded that, $\mathcal{B}(x, \vartheta) = \sum_{i=1}^{1000} \xi_i\mathcal{B}_i(x_i, \vartheta_i)$, satisfying conditions in (3.2) with $\eta = \sum_{i=1}^N \xi_i\eta_i = 0.0012$, and $\gamma = 1 + \Gamma = 0.994$.

For $a_1 = -0.3, b_1 = 0.2, a_2 = 1.01, b_2 = 1$, we compute a CBC of an order 4 as $\bar{\mathcal{B}}_i(x_i) = 0.006295x_i^4 - 0.04521x_i^3 + 0.1213x_i^2 - 0.1449x_i + 0.06662$ and corresponding controllers $\nu_i = -0.02152x_i^3 + 4$ (flow case) and $\hat{\nu}_i = -0.99x_i^3 + 2$ (jump case). Furthermore, the corresponding constants satisfying conditions (5.1a)-(5.1e) are obtained as $\bar{\mu}_i = 0.12, \bar{\beta}_i = 4.6, \bar{\kappa}_i = 0.0043, \gamma_{1_i} = 0.04547, \gamma_{2_i} = 1.00001, \bar{\varphi}_{1_i} = 1.7881 \times 10^{-5}, \bar{\varphi}_{2_i} = 1.4408 \times 10^{-5}, \bar{\eta}_{1_i} = 0.0028, \bar{\eta}_{2_i} = 0.003$. Since $\gamma_{1_i} = 0.04547 > 0$ and $\gamma_{2_i} = 1.00001 \geq 1$, Bound 2 is valid. Condition (5.3) is also met for all $\vartheta_i \in \{\varepsilon_{1_i}, \dots, \varepsilon_{2_i}\}$. Then $\mathcal{B}_i(x_i, \vartheta_i) := e^{4.54\vartheta_i}\bar{\mathcal{B}}_i(x_i)$ is a CSBC for the augmented SHS with $\gamma_i = \max\{e^{-\gamma_{1_i}\tau(1-\alpha_{1_i})}, e^{-\gamma_{1_i}\tau\alpha_{1_i}\varepsilon_{1_i}}\gamma_{2_i}\} = 0.9996, \varphi_i = \max\{e^{\gamma_{1_i}\tau\alpha_{1_i}\varepsilon_{2_i}}e^{-\gamma_{1_i}\tau}\bar{\varphi}_{1_i}, \bar{\varphi}_{2_i}\} = 1.4408 \times 10^{-5}$, and $\eta_i = \max\{e^{\gamma_{1_i}\tau\alpha_{1_i}\varepsilon_{2_i}}e^{-\gamma_{1_i}\tau}\bar{\varphi}_{1_i}\|w_i\|_\infty^2 + e^{\gamma_{1_i}\tau\alpha_{1_i}\varepsilon_{2_i}}e^{-\gamma_{1_i}\tau}\bar{\eta}_{1_i}, \bar{\eta}_{2_i}\} = 0.003$. We now proceed to construct an A-CBC based on A-CSBCs of individual subsystems according to compositionality Theorem 4.2. By choosing $\xi_i = 0.001, \forall i \in \{1, \dots, 1000\}$, one has $\xi_i\Gamma_i = -2.9745 \times 10^{-6} < 0$, implying the satisfaction of condition (4.1a). Moreover, we compute $\beta = \sum_{i=1}^{1000} \xi_i\beta_i = 4.6$, and $\mu = \sum_{i=1}^{1000} \xi_i\mu_i = 0.12$,

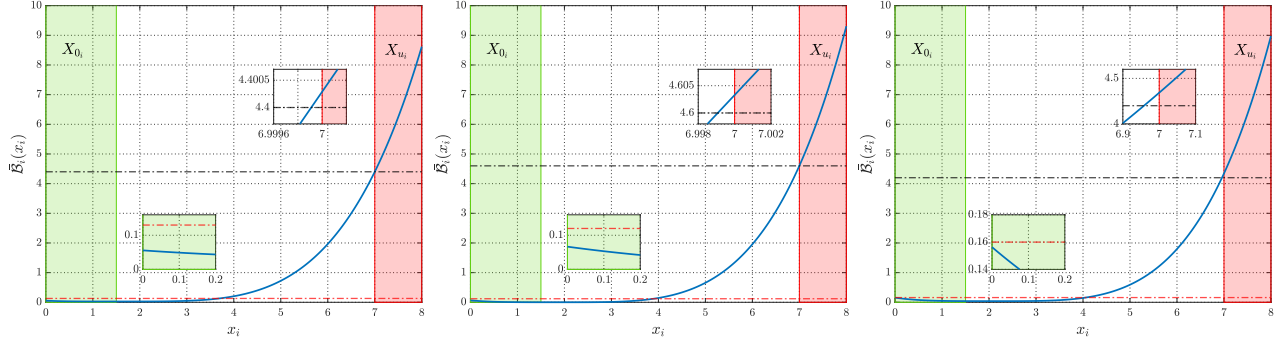

FIGURE 3. Control barrier certificate — of a representative subsystem within the interconnected SHS Φ for $a_1 = -0.4, b_1 = 0.5, a_2 = 0.01, b_2 = 0.06$ (left), $a_1 = -0.3, b_1 = 0.2, a_2 = 1.01, b_2 = 1$ (middle), $a_1 = 0.01, b_1 = 0.7, a_2 = 0.02, b_2 = 0.9$ (right). Initial and unsafe regions are depicted by green \blacksquare and red \blacksquare boxes. Moreover, $\bar{\mathcal{B}}_i(x_i) = \bar{\mu}_i$ and $\bar{\mathcal{B}}_i(x_i) = \bar{\beta}_i$ indicated by $- \cdot - \cdot -$ and $- \cdot - \cdot -$, respectively.

that imply the satisfaction of condition (4.1b). Hence, it can be concluded that $\mathcal{B}(x, \vartheta) = \sum_{i=1}^{1000} \xi_i \mathcal{B}_i(x_i, \vartheta_i)$, implying the satisfaction of conditions in (3.2) with $\eta = \sum_{i=1}^N \xi_i \eta_i = 0.003$, and $\gamma = 1 + \Gamma = 0.997$.

For $a_1 = 0.01, b_1 = 0.7, a_2 = 0.02, b_2 = 0.9$, we compute a CBC of an order 4 as $\bar{\mathcal{B}}_i(x_i) = 4.868 \times 10^{-11} x_i^6 + 2.007 \times 10^{-7} x_i^5 + 0.006941 x_i^4 - 0.05582 x_i^3 + 0.1685 x_i^2 - 0.2275 x_i + 0.1563$ and its corresponding controllers $\nu_i = -0.2852 x_i^3 + 2.5$ (flow case) and $\hat{\nu}_i = -0.09 x_i^3 + 3$ (jump case). In addition, the corresponding constants in Definition 5.1 are acquired as $\bar{\mu}_i = 0.16$, $\bar{\beta}_i = 4.2$, $\bar{\kappa}_i = 0.0043$, $\gamma_{1_i} = -0.0005$, $\gamma_{2_i} = 0.98$, $\bar{\varphi}_{1_i} = 1.7881 \times 10^{-5}$, $\bar{\varphi}_{2_i} = 1.4408 \times 10^{-5}$, and $\bar{\eta}_{1_i} = 0.004$, $\bar{\eta}_{2_i} = 0.004$. Since $\gamma_{1_i} = -0.0005 \leq 0$ and $0 < \gamma_{2_i} = 0.98 < 1$, Bound 3 is useful. Condition (5.3) is also met for all $\vartheta_i \in \{\varepsilon_{1_i}, \dots, \varepsilon_{2_i}\}$. Consequently, one can conclude that $\mathcal{B}_i(x_i, \vartheta_i) := 0.98^{\frac{\vartheta_i}{8}} \bar{\mathcal{B}}_i(x_i)$ is a CSBC for the augmented SHS with $\gamma_i = \max\{e^{-\gamma_{1_i} \tau} \gamma_{2_i}^{\frac{1}{\alpha_{2_i}}}, \gamma_{2_i}^{\frac{\alpha_{2_i} - \varepsilon_{2_i}}{\alpha_{2_i}}}\} = 0.9975$, $\varphi_i = \max\{\gamma_{2_i}^{\frac{1}{\alpha_{2_i}}} e^{-\gamma_{1_i} \tau} \tau \bar{\varphi}_{i1}, \bar{\varphi}_{i2}\} = 1.4408 \times 10^{-5}$, and $\eta_i = \max\{\gamma_{2_i}^{\frac{1}{\alpha_{2_i}}} e^{-\gamma_{1_i} \tau} \tau \bar{\varphi}_{i1} \|w_i\|_{\infty}^2 + \gamma_{2_i}^{\frac{1}{\alpha_{2_i}}} e^{-\gamma_{1_i} \tau} \tau \bar{\eta}_{1_i}, \bar{\eta}_{2_i}\} = 0.004$. We now proceed to construct an A-CBC based on A-CSBCs of individual subsystems according to compositionality Theorem 4.2. By selecting $\xi_i = 0.001, \forall i \in \{1, \dots, 1000\}$, one has $\xi_i \Gamma_i = -3.3007 \times 10^{-6} < 0$, implying the satisfaction of condition (4.1a). Moreover, we compute $\beta = \sum_{i=1}^{1000} \xi_i \beta_i = 4.2$, and $\mu = \sum_{i=1}^{1000} \xi_i \mu_i = 0.16$, that imply the fulfillment of condition (4.1b). Then, it can be concluded that $\mathcal{B}(x, \vartheta) = \sum_{i=1}^{1000} \xi_i \mathcal{B}_i(x_i, \vartheta_i)$, satisfying conditions in (3.2) with $\eta = \sum_{i=1}^N \xi_i \eta_i = 0.004$, and $\gamma = 1 + \Gamma = 0.9967$.

By employing Theorem 3.5, we guarantee that the state trajectory of Φ starting from initial conditions inside $X_0 = [0 \ 1.5]^{1000}$ remains in the safe set $[0 \ 7]^{1000}$ during the time steps $\mathcal{T} = 100$ with the probability of at least 0.973 (first bound), 0.9133 (second bound), and 0.873 (last bound). A control barrier certificate for a representative subsystem within the interconnected SHS Φ is depicted in Fig. 3. Closed-loop state trajectories

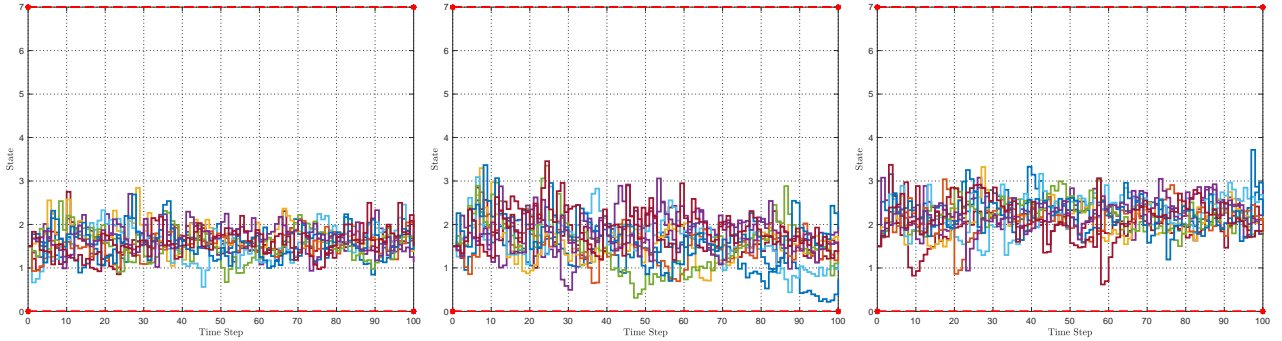

FIGURE 4. Closed-loop state trajectories of a representative subsystem within the interconnected SHS Φ with 10 noise realizations for $a_1 = -0.4, b_1 = 0.5, a_2 = 0.01, b_2 = 0.06$ (left), $a_1 = -0.3, b_1 = 0.2, a_2 = 1.01, b_2 = 1$ (middle), $a_1 = 0.01, b_1 = 0.7, a_2 = 0.02, b_2 = 0.9$ (right).

of the interconnected SHS Φ for different bounds with 10 noise realizations are depicted in Fig. 4. Note that we have only plotted trajectories at the discrete time steps since our guarantee is provided for them. The computation of CBC and its corresponding controllers for each bound took almost 5.3 seconds with a memory usage of 64.94 Mbit on a MacBook Pro M2 Max chip with 32 GB of memory.

8. CONCLUSION

In this work, we proposed a compositional framework for the safety controller synthesis of interconnected stochastic hybrid systems with both continuous and discrete evolutions. In our proposed setting, we first introduced an augmented framework to reformulate each stochastic hybrid subsystem with continuous and discrete evolutions with a unified framework covering both behaviours. We then introduced notions of augmented *control sub-barrier certificates*, constructed for each subsystem, by employing which we constructed augmented *control barrier certificates* for interconnected systems together with their safety controllers under some small-gain compositional conditions. By employing the constructed augmented control barrier certificate, we finally computed a guaranteed probabilistic bound on the safety of the interconnected stochastic hybrid systems. We verified the effectiveness of our proposed approaches by applying them to an interconnected system composed of 1000 nonlinear subsystems. Developing a compositional approach for stochastic hybrid systems capable of handling more complex logical properties beyond safety is being investigated as future work.

REFERENCES

- [ACE⁺19] A. D. Ames, S. Coogan, M. Egerstedt, G. Notomista, K. Sreenath, and P. Tabuada. Control barrier functions: Theory and applications. In *Proceedings of the 18th European Control Conference (ECC)*, pages 3420–3431, 2019.

- [ALZ22] M. Anand, A. Lavaei, and M. Zamani. From small-gain theory to compositional construction of barrier certificates for large-scale stochastic systems. *IEEE Transactions on Automatic Control*, 67(10):5638–5645, 2022.
- [APLS08] A. Abate, M. Prandini, J. Lygeros, and S. Sastry. Probabilistic reachability and safety for controlled discrete-time stochastic hybrid systems. *Automatica*, 44(11):2724–2734, 2008.
- [ASBA19] M. Ahmadi, A. Singletary, J. W. Burdick, and A. D. Ames. Safe policy synthesis in multi-agent POMDPs via discrete-time barrier functions. In *Proceedings of the 58th Conference on Decision and Control (CDC)*, pages 4797–4803, 2019.
- [BK08] C. Baier and J.-P. Katoen. *Principles of model checking*. MIT press, 2008.
- [BLE⁺06] H. AP. Blom, J. Lygeros, M. Everdij, S. Loizou, and K. Kyriakopoulos. *Stochastic hybrid systems: theory and safety critical applications*, volume 337. Springer, 2006.
- [BWAE15] U. Borrmann, L. Wang, A. D. Ames, and M. Egerstedt. Control barrier certificates for safe swarm behavior. *IFAC-PapersOnLine*, 48(27):68–73, 2015.
- [CL06] C. G. Cassandras and J. Lygeros. *Stochastic hybrid systems*. CRC Press, 2006.
- [Cla19] A. Clark. Control barrier functions for complete and incomplete information stochastic systems. In *Proceedings of the American Control Conference (ACC)*, pages 2928–2935, 2019.
- [Dyn65] E. B. Dynkin. Markov processes. pages 77–104. Springer, 1965.
- [Gro19] T. H. Gronwall. Note on the derivatives with respect to a parameter of the solutions of a system of differential equations. *Annals of Mathematics*, pages 292–296, 1919.
- [HHHK13] E. M. Hahn, A. Hartmanns, H. Hermanns, and J.-P. Katoen. A compositional modelling and analysis framework for stochastic hybrid systems. *Formal Methods in System Design*, 43(2):191–232, 2013.
- [JLZ22] N. Jahanshahi, A. Lavaei, and M. Zamani. Compositional construction of safety controllers for networks of continuous-space POMDPs. *IEEE Transactions on Control of Network Systems*, 10(1):87–99, 2022.
- [JP09] A. A. Julius and G. J. Pappas. Approximations of stochastic hybrid systems. *IEEE Transactions on Automatic Control*, 54(6):1193–1203, 2009.
- [Kus67] H. J. Kushner. *Stochastic Stability and Control*. Mathematics in Science and Engineering. Elsevier Science, 1967.
- [Lav24] A. Lavaei. Abstraction-based synthesis of stochastic hybrid systems. In *Proceedings of the 27th ACM International Conference on Hybrid Systems: Computation and Control*, pages 1–11, 2024.
- [LF24] A. Lavaei and E. Frazzoli. Scalable synthesis of safety barrier certificates for networks of stochastic switched systems. *IEEE Transactions on Automatic Control*, 2024.
- [LSAZ22] A. Lavaei, S. Soudjani, A. Abate, and M. Zamani. Automated verification and synthesis of stochastic hybrid systems: A survey. *Automatica*, 146, 2022.
- [LSF22] A. Lavaei, S. Soudjani, and E. Frazzoli. Safety barrier certificates for stochastic hybrid systems. In *American Control Conference (ACC)*, pages 880–885, 2022.
- [LZ22] A. Lavaei and M. Zamani. From dissipativity theory to compositional synthesis of large-scale stochastic switched systems. *IEEE Transactions on Automatic Control*, 67(9):4422–4437, 2022.
- [NPNS24] A. Nejati, S. Prakash Nayak, and A.-K. Schmuck. Context-triggered games for reactive synthesis over stochastic systems via control barrier certificates. In *Proceedings of the 27th ACM International Conference on Hybrid Systems: Computation and Control*, pages 1–12, 2024.
- [NZ20] A. Nejati and M. Zamani. Compositional construction of finite MDPs for continuous-time stochastic systems: A dissipativity approach. *IFAC-PapersOnLine*, 53(2):1962–1967, 2020.
- [NZ22] A. Nejati and M. Zamani. From dissipativity theory to compositional construction of control barrier certificates. *Leibniz Transactions on Embedded Systems (LITES) (Special Issue on Distributed Hybrid Systems)*, 8(2), 2022.

-
- [Oks13] B. Oksendal. *Stochastic differential equations: an introduction with applications*. Springer Science & Business Media, 2013.
- [ØS05] B. K. Øksendal and A. Sulem. *Applied stochastic control of jump diffusions*, volume 498. Springer, 2005.
- [Par03] P. A. Parrilo. Semidefinite programming relaxations for semialgebraic problems. *Mathematical programming*, 96(2):293–320, 2003.
- [PAV⁺13] A. Papachristodoulou, J. Anderson, G. Valmorbida, S. Prajna, P. Seiler, and P. Parrilo. SOSTOOLS version 3.00 sum of squares optimization toolbox for MATLAB. *arXiv:1310.4716*, 2013.
- [PJ04] S. Prajna and A. Jadbabaie. Safety verification of hybrid systems using barrier certificates. In *Proceedings of the International Workshop on Hybrid Systems: Computation and Control (HSCC)*, pages 477–492, 2004.
- [PJP07] S. Prajna, A. Jadbabaie, and G. J. Pappas. A framework for worst-case and stochastic safety verification using barrier certificates. *IEEE Transactions on Automatic Control*, 52(8):1415–1428, 2007.
- [SDC19] C. Santoyo, M. Dutreix, and S.I Coogan. Verification and control for finite-time safety of stochastic systems via barrier functions. In *Proceedings of the IEEE Conference on Control Technology and Applications*, pages 712–717, 2019.
- [Stu99] J. F. Sturm. Using SeDuMi 1.02, a MATLAB toolbox for optimization over symmetric cones. *Optimization methods and software*, 11(1-4):625–653, 1999.
- [WHL24] Ben Wooding, Viacheslav Horbanov, and Abolfazl Lavaei. PRoTECT: Parallelized construction of safety barrier certificates for nonlinear polynomial systems. *arXiv:2404.14804*, 2024.
- [WTL15] T. Wongpiromsarn, U. Topcu, and A. Lamperski. Automata theory meets barrier certificates: Temporal logic verification of nonlinear systems. *IEEE Transactions on Automatic Control*, 61(11):3344–3355, 2015.
- [ZRRH10] Z. Zhang, L. and She, S. Ratschan, H. Hermanns, and E. M. Hahn. Safety verification for probabilistic hybrid systems. In *CAV*, pages 196–211, 2010.