

A blueprint for large-scale quantum-network deployments

Alberto Sebastián-Lombrana, Hans H. Brunner, Juan P. Brito, Rubén B. Méndez, Rafael J. Vicente, Jaime S. Buruaga, Laura Ortiz, Chi-Hang Fred Fung, Momtchil Peev, José M. Rivas-Moscoso, Felipe Jiménez, Antonio Pastor, Diego R. López, Jesús Folgueira and Vicente Martín

Abstract—Quantum Communications is a field that promises advances in cryptography, quantum computing and clock synchronisation, among other potential applications. However, communication based on quantum phenomena requires an extreme level of isolation from external disturbances, making the transmission of quantum signals together with classical ones difficult. A range of techniques has been tested to introduce quantum communications in already deployed optical networks which also carry legacy traffic. This comes with challenges, not only at the physical layer but also at the operations and management layer. To achieve a broad acceptance among network operators, the joint management and operation of quantum and classical resources, compliance with standards, and quality and legal assurance need to be addressed.

This article presents a detailed account of solutions to the above issues, deployed and evaluated in the MadQCI (Madrid Quantum Communication Infrastructure) testbed. This network is designed to integrate quantum communications in the telecommunications ecosystem by installing quantum-key-distribution modules from multiple providers in production nodes of two different operators. The modules were connected through an optical-switched network with more than 130 km of deployed optical fibre. The tests were done in compliance with strict service level agreements that protected the legacy traffic of the pre-existing classical network. The goal was to achieve full quantum-classical compatibility at all levels, while limiting the modifications of optical transport and encryption and complying with as many standards as possible. This effort was intended to serve as a blueprint, which can be used as the foundation of large-scale quantum network deployments. To demonstrate the capabilities of MadQCI, end-to-end encryption services were deployed and a variety of use-cases were showcased.

Index Terms—Quantum networks, optical networks, quantum key distribution, quantum communications.

Alberto Sebastián-Lombrana, Juan P. Brito and Vicente Martín are with Universidad Politécnica de Madrid, Madrid, Spain; with Dept. LSIIIS, at the E.T.S.I.Inf, Boadilla del Monte, Spain; and with Center for Computational Simulation, Madrid, Spain.

Rubén B. Méndez, Rafael J. Vicente, and Jaime S. Buruaga are with Universidad Politécnica de Madrid, Madrid, Spain; and with Center for Computational Simulation, Madrid, Spain.

Laura Ortiz is with Universidad Politécnica de Madrid, Madrid, Spain; with Dept. DATSI, at the E.T.S.I.Inf, Boadilla del Monte, Spain; and with Center for Computational Simulation, Madrid, Spain.

Hans H. Brunner, Chi-Hang Fred Fung, and Momtchil Peev are with Munich Research Center, Huawei Technologies Duesseldorf GmbH, Munich, Germany.

José M. Rivas-Moscoso, Felipe Jiménez, Antonio Pastor, Diego R. López and Jesús Folgueira are with Telefónica gCTIO/TID, Madrid, Spain.

Manuscript created September, 2023.

I. INTRODUCTION

THERE is a growing interest in the use of quantum-enhanced services, mainly based on quantum key distribution (QKD) [1, 2]. However, this requires the ability to manipulate signals at the quantum level and, consequently, the deployment of new technologies with very demanding technical requirements.

The principles of quantum mechanics imply that the measurement of a quantum signal alters it. Passive networks, without active elements such as amplifiers, must be used for its transmission. The propagation of signals at the quantum level in physical media—typically the optical fibre—entails absorption probability that dramatically limits their range. If the medium is shared, other quantum or classical signals may limit the range even further. In the case of optical fibres, deployment is typically the most expensive part and co-propagation is essential. Until quantum repeaters are developed [3], it is necessary for QKD networks to handle these limitations.

Equally relevant to the success of quantum communications is the provision of quantum-enhanced services. This involves the joint operation and management of quantum and classical resources, which requires low-level enabling techniques allowing sharing the underlying physical infrastructure. To achieve widespread deployment, interoperability of deployed systems, standardisation, certification of quantum networks and devices, compliance with regulations, and quality assurance, are also a must. MadQCI [4] is designed to be heterogeneous at the quantum as well as at the classical network level, to comprehensively address these problems. It is also large and complex enough to significantly advance the state of the art. To date, with three years of continuous operation, MadQCI is the most complex, largest, and longest running testbed for quantum-communication technologies in Europe. To realise a diverse network and perform a comprehensive investigation, multiple technologies from various vendors were installed. The 26 QKD modules came from three different manufacturers, some using continuous-variable QKD (CV-QKD) and others discrete-variable QKD (DV-QKD). Table I summarises the main features of the network.

The complexity of the network was tackled using several administrative domains. The infrastructure was hosted in production premises of two network operators: Telefónica Innovación Digital (TID), the research and development division of the incumbent telecommunications operator in Spain, and the research and education network operator in the region

TABLE I: Summary of MadQCI features by domain.

Domain	Nodes	QKD links	Total link length	QKD modules	Encrypt. modules
TID	3	3 + border	38.4 km	7	3
RM	6	6 + border	91.4 km	9	2
Co-located	7	all-to-all	98.7 km	10	6

of Madrid, REDIMadrid (RM). In addition, a third (logical) domain was used to handle the testing of a switched QKD network. This specific sub-network is referred to as the “co-located domain” and contains all the devices that support switching [5, 6]. The network configuration resembles production networks—including the inter-domain border link—re-using already installed resources and adding new ones as required.

Regardless of the domain, the operation and management of the overall quantum network was based on a software-defined approach [4] to quantum networking. In the software-defined networking (SDN) paradigm, forwarding-plane resources are programmable and expose their capabilities through common and open interfaces [7]. In this way, the operation and management system not only configures and commands the resources, but also achieves the overall programming of the network for application-specific behaviour and performance. This design is very flexible and allows an easier integration of quantum resources in existing classical networks. In MadQCI, this paradigm enables the transparent operation and management of both the quantum and classical equipment, required for quantum-secure communications and services.

As a result, cryptographic keys could be distributed between any pair of nodes in the network, independently of the QKD manufacturer and network operator. These capabilities were exposed to applications through standardised interfaces, which benefited from the programmability of the network as a whole. The outcome allowed the execution of a wide variety of use cases [4, 8, 9] based on quantum-distributed keys. Specific hardware was installed to provide encryption at OSI layers 1 and 2. Software applications allow secure communication on higher OSI layers, such as an IPsec implementation [10] and one based on TLS [11].

The paper is organised as follows. In the next sections, the related work and an overview about quantum and optical communications is outlined and the coexistence and integration approach of classical and quantum optical networks is discussed. Then, a detailed description of the solutions implemented in MadQCI and its main performance are presented to serve as a blueprint for large-scale quantum network deployments. The paper finishes with conclusions and an outlook.

II. RELATED WORK

Quantum cryptography has been the first major technological realisation of quantum communication and QKD grew around the idea of using optical communications and networks since its earliest days. Examples include the Boston testbed [12], which already involved optical networking techniques such as switching or dense wavelength division multiplexing (DWDM). Other well-known examples are the Vi-

enna [13] and Tokyo [14] quantum networks, which used dark optical fibres deployed in the field. The first iterations of MadQCI also date back to that time [15], along with others such as the Hefei testbed [16].

Most of these practical exercises focused on showing the capabilities of quantum-communication developments, rather than on how to install these into existing infrastructures [17]–[21]. In contrast, the efforts in MadQCI have been aligned with this last goal since its early days. Novel optical networking approaches to quantum communication were proposed [22] and it was shown how a pioneering commitment to a software-defined approach for quantum networking enables a fast and flexible convergence of quantum and classical communication in production environments [23, 24]. Furthermore, the MadQCI team is a leading actor in the standardisation of QKD communication at ETSI ISG QKD [25], which promotes a dialogue between industrial actors such as manufacturers and network operators.

In parallel, numerous technological improvements over the last decade have brought QKD to a commercial status. Deployments such as the 2,000 km Beijing-Shanghai QKD link and further extensions of the China QKD Network [26, 27] as well as the 4,600 km long QKD space segment [28] have demonstrated the feasibility of quantum secured backbone networks. Other examples demonstrate the penetration of these technologies in specific niches, such as the ability of the Hefei quantum network to efficiently encrypt the institutional telephone traffic [29] or the efforts in Bristol to securely transport subscriber databases in 5G [30].

Since 2019, a broad effort is underway to establish the European Quantum Communications Infrastructure (EuroQCI), a pan-European quantum network based on the results of several projects funded by Quantum Flagship [31] and Digital Europe [32] research programmes, among others. Examples of these projects are OpenQKD [8], CIVIQ [33], and the current QSNP [34], which strongly contribute to results discussed in this paper. Currently, there are several efforts to deploy quantum communication infrastructures (QCI) in Europe. A list of these can be found in [35].

The next big step in the adoption of quantum communication is the leap to the space segment, since it would enable worldwide quantum connectivity. Also, further progress is being made in other types of quantum communications such as quantum entanglement distribution—to enable the so called “quantum internet” [36]—or other quantum-enhanced applications such as quantum clock synchronisation [37]. Communication infrastructures are being prepared to support any kind of quantum communication, beyond quantum cryptography.

III. QUANTUM AND OPTICAL COMMUNICATIONS OVERVIEW

This section introduces some topics in telecommunications and quantum technologies, particularly those transmitting in optical fibres that are needed in the subsequent discussion.

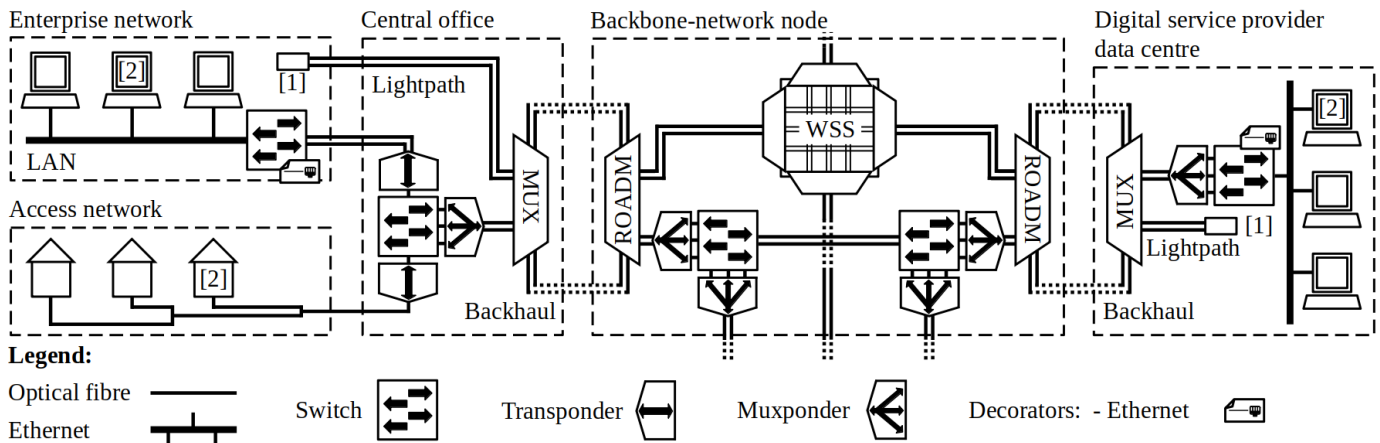

Fig. 1: This figure illustrates the complexity and diversity of optical communications. On the left, two access networks are shown, an enterprise and a home network based on passive optics. In the centre, two (highly simplified) nodes of a typical optical network are depicted, one dedicated to the aggregation of multi-purpose subscriber traffic—and possibly with FOADM optics—and one backbone for handling large volumes of traffic, typically with equipment such as ROADMs. On the right is a data centre of a digital service provider, operating over-the-top of the network operator. In terms of subscriber provision, the optical network is delivering two services: [1] provision of lightpaths and [2] carrying and processing of traffic. The target is to integrate quantum communication technology with all types of traditional (classical) optical fibre-based communication.

A. Production networks

When considering the realization of quantum technologies in optical networks, it is necessary to build on a suitable model, which may differ depending on the nature of the requirements [38].

The current networking landscape relies on several heterogeneous communication systems with different design, technology, and service fundamentals. Besides, each of them has a different degree of interoperability, often limited by the commercial strategy of the respective vendors. Examples are the more traditional Ethernet-based local area networks; the passive optical networks (PONs) for home access; or the optical networks for aggregation and backhaul, as depicted in Fig. 1. All operate over optical fibres and can carry the same type of traffic. However, they have different requirements for the deployment of new systems. In addition, network operators and service providers must comply with legal and regulatory requirements—e.g. critical infrastructure protection, lawful interception, and secrecy of communications—that prevent the deployment of novel devices without certification and industry-wide standardisation. The deployment of quantum communication adds additional requirements to these already overloaded designs, all of which have to be integrated to deliver cutting-edge services.

Different industrial and commercial approaches should also be taken into account when modelling the optical networks. Network operators focus their activities on the transport of information between their subscribers. Thus, their network design must deal with the complexity of equipment spread across customer sites and central offices, while assuring the aggregation and transport of multi-service traffic. Whereas, in the case of digital service providers, the complexity lies in their multi-tenant, distributed data centres, which are interconnected “over-the-top” of the network operator, abstracting

the complexity of many parts of the network. The notion of quantum communications and the service they provide can be fundamentally different in these scenarios, and involves aspects ranging from regulatory issues to how or whom to bill for these services.

A description of a network can be obtained by outlining its functionalities, usually classified in functional planes—i.e., the forwarding, control, management, application, etc. planes—. The previously explained context fixes how, when, and where those functionalities are executed. In this respect, a production network cannot be modeled as a naive graph of connected nodes. It is common for forwarding-plane functionalities, i.e., those functions that enable the transport of information over the different transmission media, to reside at all nodes of a network. However, the majority of the control-plane functionalities may reside in a single centralised component. In this case, the unavailability of a single node may compromise the connectivity of the entire graph. Furthermore, other elements, such as the facilities that physically host the forwarding devices and provide security and privacy to the system, are also functional to the network. Therefore, a more appropriate model should include which network functionalities are performed on which element, with a focus on the specific end use or application.

This paper attempts to incorporate these insights into discussions on the coexistence of classical and quantum technologies.

B. Optical networks

From a technological point of view, an optical network is a communication infrastructure capable of providing lightpaths. In this sense, circuits are more important than packets or datagrams for this model. Each lightpath carries optical signals that encode subscriber traffic. In some cases, a lightpath may

be managed and operated directly by the customer—e.g., a dark optical fibre is leased by a digital service provider to connect some remote data centres—.

The optical network typically uses wavelength division multiplexing (WDM). Although a bidirectional approach is possible, duplexing is usually achieved by using pairs of optical fibres, one for receiving and one for transmitting. Transceivers encode the subscriber traffic in optical signals for specific duplexing and WDM channels.

Multiple elements such as filters, multiplexers—e.g., optical add-drop multiplexers (OADM)—, cross-connection systems, etc., enable the steering of these signals. In order to achieve long range transmissions, signal re-amplification, re-shaping or re-timing techniques are implemented. In many cases it is not possible to separate these elements from the frame they carry. For example, a muxponder that aggregates and de-aggregates several information streams to optimise the transmission of large volumes of data may only work for a particular technology—for example, those specific to SDH/SONET—

Finally, several versions or generations coexist in industry to achieve a higher or lower reconfigurability of lightpaths, as also depicted in Fig. 1. A common approach is called “FOADM”, which stands for fixed OADM. In these designs, elements such as fixed filters and multiplexers prevail, i.e., without the possibility of changing their frequency selectivity. Re-tunable transceivers may be used, depending on the connectivity requirements in the assembly. The “ROADM” approach uses precisely reconfigurable OADMs or analogous elements. This means that the optical mesh can be reconfigured by means of frequency selective elements to establish new lightpaths on demand. The degree of meshing may not be all-with-all, and hybrid approaches are possible—e.g., FOADM in the access network and ROADM in the backbone, or vice versa—.

The result will be a meshed network capable of transmitting and receiving both information flows and lightpaths between nodes. The degree of meshing, the degree of reconfigurability of the lightpaths, the use of specific optics—such as passive optics for home access—, among other decisions, is determined by the design. The preferred design depends on the trade-off between performance—which includes not only throughput, but also latency, connectivity, availability—and cost.

C. Quantum key distribution and cryptographic applications

The main quantum communication technique currently exploited is QKD, due to its level of maturity. However, experiments are also being conducted with other primitives of quantum cryptography, e.g., quantum oblivious key distribution for performing oblivious transfer [9].

QKD provides synchronised sources of symmetric cryptographic keys between two remote systems [1, 2]. This technique relies on quantum physics to deliver information-theoretically secure (ITS) keys to a final cryptographic application [39], as Fig. 2 shows. Indeed, an ITS cryptosystem cannot be broken even if the adversary has unlimited (quantum)

computing power together with ultimately efficient algorithms. Therefore, in theory, QKD generates unpredictable and unbreakable cryptographic keys, immune to any cryptanalysis, even such that may arise by replacing the communication channel by an adversarial quantum computer, or, as a corollary, by any quantum computing algorithms, which do threaten traditional key-exchange systems [40].

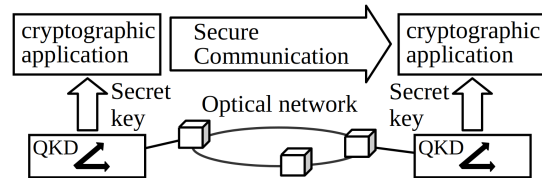

Fig. 2: Main scheme to deliver end-to-end quantum-secured cryptography using QKD. The symmetric quantum-distributed key is delivered to both ends of a cryptography system. For this, either a point-to-point QKD link exists, or an approach, based on trusted nodes, that allows hop-by-hop key forwarding is used.

Since optical quantum channels suffer from a series of limitations regarding throughput and range, a network is needed to provide any significant end-to-end service. The quantum information is carried embedded in quanta of energy which, by their nature, are extremely sensitive to interactions. A widely used approach to achieve end-to-end key distribution is using “trusted nodes”, intermediate trusted nodal sites where forwarding operations can be carried out without compromising the security as a consequence of the stated trustworthiness of the locations. In each node, a component named “forwarding module” (FM) performs a key transport protocol, consuming the generated key and using another ITS primitive—e.g., Vernam encryption [41]—for ciphering and deciphering the final distributed key in each hop. (Additionally ITS message authentication is employed, as discussed e.g. in [13].)

This enables end-to-end quantum-enhanced services both between remote subscribers and the optical network itself—e.g., by utilizing encryptors [42] for protecting the subscriber traffic—. In practice, cryptosystems based on QKD are not ITS. Any implementation requires assumptions which may not exactly reproduce a theoretical model. In any case, all elements of the network as a whole must be as secure as possible.

D. Management and operation. Software-defined networking

Central to the evolution of telecommunication networks is their operation, administration, and management functionality, as it determines the overall performance of the systems [38]. They are also essential to achieve the interoperability between systems.

As described above, current networks are heterogeneous, based on different technologies, generations or vendors, but their management should be integrated. Traditionally, the network management and operation is achieved using techniques such as signalling channels or the direct configuration of devices—e.g., with SNMP [43]—.

Software-defined networking enables network programmability for enhancing the service provided [7, 44]. Traditionally, network equipment was designed to save costs by limiting its configurability and focusing on performing specific tasks. Modern approaches promote the supply of more open and general-purpose equipment, often making use of software engineering techniques, such as exposing its functionality through software interfaces or domain-specific programming languages. This allows decoupling of functional planes, both the control and forwarding planes as well as the application plane; component disaggregation; and other software-enabled techniques such as virtualisation. In most cases, the SDN design assumes a logical centralisation of the control functions into a specific component called controller, which manages the underlying general-purpose infrastructure. The result is a network that can be programmed to meet the requirements of each application, either in concrete sense—e.g., each network usage per subscriber—or abstract—high-performance usage or low-energy impact usage—.

Analogously, quantum networks can adopt this approach. In fact, this work discusses and applies the concept of the “quantum forwarding plane” (QFP): functionalities that enables the end-to-end quantum-enhanced provision. This includes FMs that enable key forwarding in trusted nodes, as well as quantum information systems—e.g., QKD systems—and other infrastructure elements. All the elements in the QFP may be controlled by a unique control plane. This will be fundamental for the integration of quantum technologies in telecommunications. A proper and joint management of classical and quantum resources can address low-level issues, such as sharing the underlying infrastructure, as well as other already mentioned issues, such as security, legal requirements, and quality assurance.

These and other topics are the subject of standardization, which is a fundamental task for QKD networks. The work described in this manuscript benefits from the standardisation activities on SDN in quantum networking [23, 24] driven by the ETSI GS QKD industry specification group.

In this regard, the ETSI GS QKD 015 specification [45] describes a software-defined node in QKD networks as a set of components, including the QKD modules, which handle quantum signals and protocols, and the set of local key management systems (LKMS), that securely manage the key and invoke the (integrated) FMs that forward it. Fig. 3 depicts this design. This specification also determines an information model that enables controlling every nodal component in a software-defined way. The subscribers may request end-to-end QoS-driven QKD services by ETSI GS QKD 004 [46], passing the use-specific requirements to be fulfilled by the network. Other specifications, such as ETSI GS QKD 018 [47], enable inter-domain orchestration or key management inter-operation. The architecture of the network elements is also being standardized to include the definitions of the QFP and FM used above [48, 49].

Optical networks can be operated and managed this way using so-called SDN protocols—e.g., NETCONF [50]—, YANG modelling language [51], and information models such as Transport API [52] or OpenROADM [53]. This approach

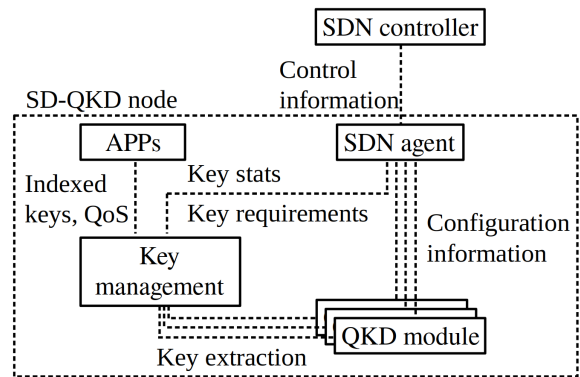

Fig. 3: The architecture of a node in a software-defined QKD network as specified in the ETSI GS QKD 015 specification and implemented in MadQCI.

enables the necessary compatibility to operate and manage both classical and quantum resources in a joint manner.

E. Optical quantum networks

This section connects what was described so far to discuss the coexistence and integration of quantum communications in optical networks.

Quantum signals are of very low power and sensitive to extremely weak interactions [18]. When transmitted in a shared optical fibre, the Raman effect and four-wave mixing of adjacent channels can cause disturbances in the quantum channels [54, 55]. As a consequence, the management of the quantum and classical channels allocation is fundamental [56]. Active components, such as signal amplifiers, are destructive for the quantum nature of signals, regardless of the re-amplification, re-shaping or re-timing technique that they implement. The possibility of using other signal inverse reshaping passive methods, such as polarisation or dispersion compensation, may depend on the nature of the quantum communication.

In optical networking, multiplexers and other elements are not perfect and their effects, e.g., crosstalk between channels, signal reflections, and backscattering might influence the guardband communications [18, 57, 58]. As a result, coexistence must be implemented with optical equipment with good inter-channel isolation and limited launch power of the classical signals. Networks adopting the ROADM approach often use equipment that integrates amplification by design, such as wavelength selective switches (WSS). The quantum channels have to be dropped, filtered and added outside of the WSS to comply with the requirements. These restrictions have a direct impact on both the design and technology selection for the network.

When adopting such solutions, the requirements on the classical signals need to be managed for enforcing protection of the quantum channel. The power control negatively influences the propagation of classical signals. In order not to disturb a quantum system, it might be necessary to reduce the launch power of a classical channel so that the received power falls below the sensitivity of the classical receiver. These

requirements could be met with better equipment or additional amplification on the receiver side once the channel has been dropped.

For many of the problems, noted above, interoperability between the control and management functionalities of all elements becomes critical. If the operation and management system for the quantum resources can interoperate with that of the optical infrastructure, information can be consolidated and decisions can be made to increase performance. However, it is fundamental that industry-wide standards are developed to facilitate such coexistence and integration.

F. Coexistence and integration approach

To conclude the discussion, a successful approach to integrate quantum elements in optical networks is presented, which is the one followed in the deployment of MadQCI. Two abstractions have been used primarily: functional planes, which are very common in SDN discussions, and network components, used in architectures such as the one described in ETSI GS QKD 015. Other abstractions are possible, such as describing the QKD network in terms of its layers—e.g., quantum, key management and communication layers [14]—, but this work does not do so.

In this respect, the architecture implied by ETSI GS QKD 015 focuses on the control plane and abstracts other elements. It explicitly includes the QKD modules and the controller-agent assembly, but it does not include other elements that enable them, such as the shared optical network or the IT systems. Furthermore, that specification does not deal explicitly with the FM. Therefore, this work provides a more detailed architecture clues than the ETSI GS QKD 015 specification.

The design of each node will be the set of components that performs all the network functionalities, both classical and quantum. In quantum cryptography, this involves both the key management functionalities and those that enable the networking. An example of the former can be a hardware security module (HSM) for the secure handling of cryptographic keys or the management of different subscribers. This type of equipment exists in other fields and is subject to highly demanding standards, so security should not be compromised [59]. The latter includes the QFP components that enable a controlled and managed forwarding of both quantum signals and quantum-distributed resources. Fig. 4 shows a general scheme of the architecture implied in this work, based on a set of components that allows quantum and optical technologies to coexist.

From top to bottom, the ensemble is arranged to allow both hardware and software-based subscriber traffic, both of which will require quantum-distributed keys. This distribution is made possible by components that simultaneously control and manage the key and infrastructure network elements (NE). In a complex case, this will be done holistically, in a single network control with a comprehensive view of the network, but several control and management systems may be necessary. Additionally, key management systems [59] will be needed to secure the generated keys, if they are not included in other elements.

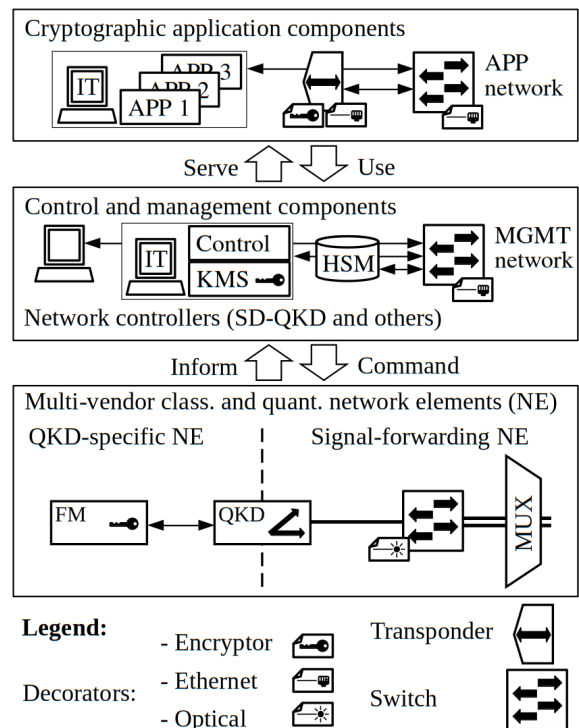

Fig. 4: The image shows the set of components that would enable the coexistence of quantum and classical communication technologies in optical networks. It includes all the elements necessary for the provision of the service: 1) the cryptographic applications that will consume the key, 2) the network and key control systems and 3) the network elements (NE) both QKD-specific and signal-forwarding NEs. These last elements that guide, aggregate or switch signals do not necessarily have to be located at the trusted nodes, since quantum protocols ensure security over the lightpath, but it is desirable to have control over them. Both NEs are called the (quantum) forwarding plane if the network is SD-QKD, as described in the text. It is also relevant that it includes the forwarding module (FM) that transports the key. Despite routing not being a key management functionality [59], it has been usually assumed to be part of the LKMS in the QKD literature.

Finally, at the bottom, the NEs that are the infrastructure for the rest of the components are represented. Those that are specific to the QKD, such as the FMs that carries the key, and those that forward the signals to enable the connectivity of the former —e.g., the shared optical components or the data network that communicates the FMs— are shown separately. QKD modules have been represented as part of both sets, since they perform both QKD functions —e.g., running QKD protocols such as BB84— and network functions: generating the signals adapted to the media or switching their emission frequency to route the signal in a FOADM network are examples.

If the network is SD-QKD, these infrastructure elements would be the programmable ones. With programmable interfaces, such as those defined by ETSI GS QKD 004 or

ETSI GS QKD 018, applications can request enhanced services from the network thanks to a heterogeneous set of resources.

The result is a node ready to be integrated an optical network with quantum technologies focusing on cryptographic applications, mainly based on QKD.

IV. MADQCI, A BLUEPRINT FOR QUANTUM NETWORKING

This section describes MadQCI as a model for the benefit of other QCI deployments. The fundamentals described so far were taken into account during its design and deployment, so it is a specific realization of those. The aim is to detail the problems that were addressed and the solutions applied to provide a blueprint for any large-scale quantum network deployment of the discussed SDN class.

In particular, these details concern the three years in which the testbed was running during the OpenQKD and CIVIQ projects. Its scope make it possible to describe features that had not been present so far in the state of the art, as it was the most complex, largest and longest running testbed for quantum communication technologies in Europe. Fig. 5 depicts the layout of MadQCI.

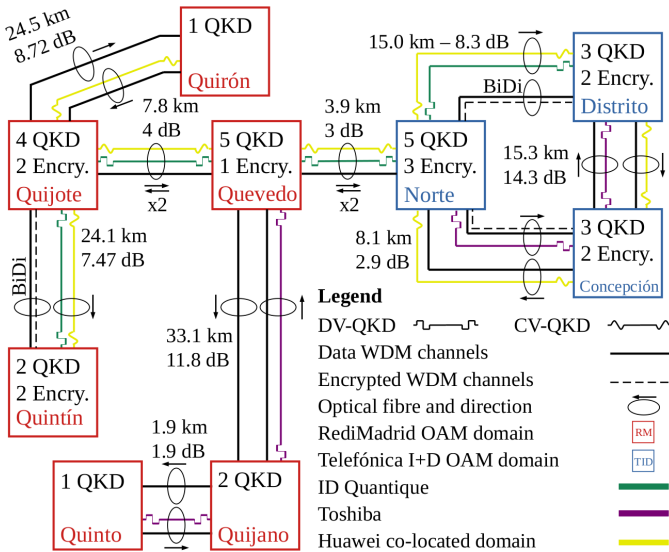

Fig. 5: MadQCI overview. 26 QKD modules from different manufacturers were installed in the 9 production facilities of RM and TID. More than 130 km of fibre optic pairs supported both classical and quantum signals including, in some cases, third party traffic. Three OSI level 1 encrypted links were deployed, as well as 6 level 2 Ethernet encrypting devices. A single pair of optical fibres was used in each inter-node connection, but different schemes of coexistence were implemented. The link between Quevedo and Norte was co-managed as a border connection.

Additionally, the key distribution and network operation and management was performed as much as possible in an SDN-aware manner. The approach followed was based on the general design outlined in section III-F. The level of integration with each component depended on its level of SDN-awareness.

The network supported several use cases and demonstrators of different projects. Specific hardware was installed to provide encryption at OSI levels 1 and 2 (ADVA and R&S respectively). A level 3 IPsec [10] and TLS [11] software implementations were also tested. The result allowed the execution of a wide variety of use cases [4, 8, 9] enhanced with quantum-distributed keys.

A. Premises and equipment

The uniqueness of MadQCI is that it resulted in a heterogeneous network installed in real-world production optical networks, with multi-vendor equipment and meeting the requirements of the two network operators involved.

1) *Classical-specific equipment*: REDIMadrid is the research and education network in the region of Madrid and provides connectivity services to several Madrilenian universities and research centres. Its infrastructure is meant for delivering IP-based connectivity services and it is outfitted with production-grade optical network devices—e.g., Ciena 6500 or Adva FSP 3000—. RM facilities are mainly central offices or communication rooms, which fulfilled the security requirements of trusted zones (i.e. trusted nodes). The network implements path diversity and redundant channels, so that quantum integration could be tested without risking the service delivery.

The premises available in the Telefónica Innovación Digital domain were production central offices. These facilities enabled the daily operation of communication services by connecting the wired and radio subscriber access networks to the backbone transport networks. As such, they were much more regulated critical infrastructures—e.g., taking pictures of the equipment once installed was not authorised—, suitable for being considered trusted locations (trusted nodes) and therefore for validating QKD-powered, secure communication solutions. This is also why the MadQCI network was designed in this segment from scratch and used dedicated equipment and non-illuminated fibres.

In both network domains, the quantum-communication technologies, both quantum and networking, were installed in regular 19" rack cabinets and had a power supply of 240 V, which fits the industrial standards. At the Norte and Concepción nodes—i.e., central offices of the TID domain—power inverters were used to adapt the direct current typically used in these facilities. In all the premises, there were regular cooling conditions. The optical transmission media were standard fibres—e.g., ITU-T G.652—and production-grade connectors were used, such as LC or SC with different polishes. Fig. 6 shows several examples of the deployed quantum and classical equipment.

For delivering the quantum-safe services, both software and hardware resources were deployed. The hardware devices were network encryption equipment consuming the quantum-distributed key to cipher the subscriber traffic while performing their network tasks. High-security Rohde & Schwarz SIT-Line ETH encryptors were deployed for supporting ciphered L2 connectivity services. Analogously, some ADVA 5TCE-PCTN-10GU+AES10G modules were installed to enable L1

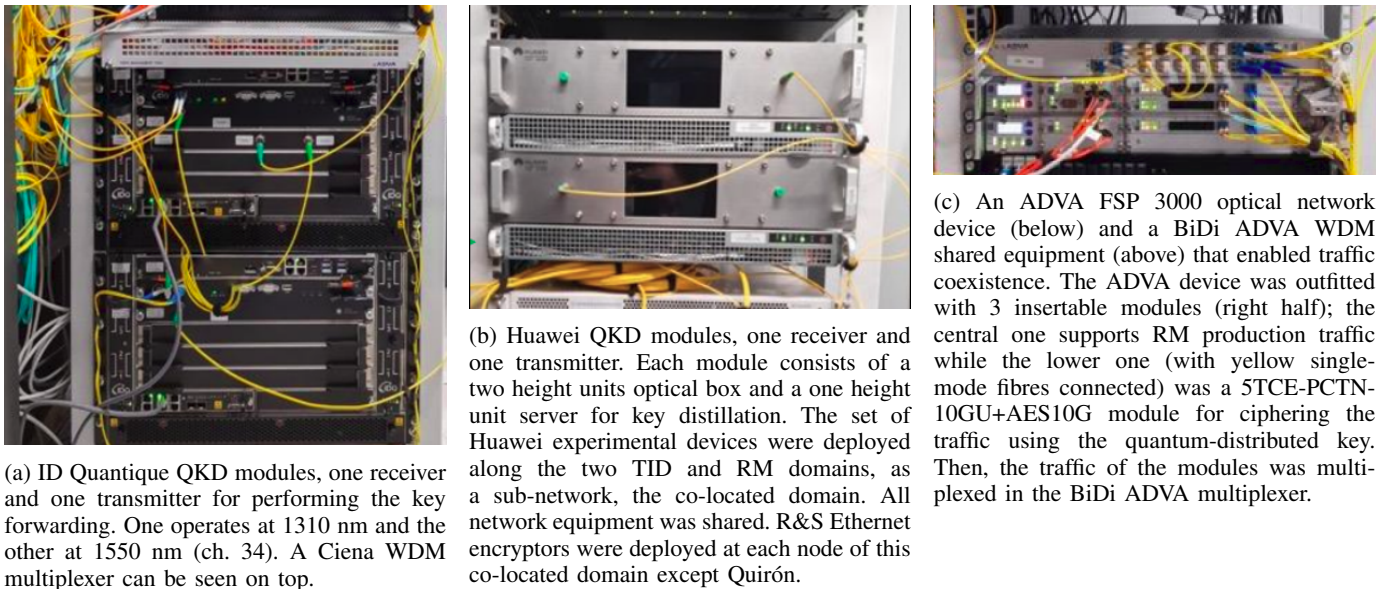

Fig. 6: Different examples of the equipment deployed in MadQCI, in the Quijote node in this case. All devices displayed here were mounted in the same 19" rack cabinet.

encryption [42]. Regarding the software applications, the domain-specific use cases were demonstrated using the same IT systems that ran the SDN-inspired control and management system, described in the section IV-C.

2) *Quantum-specific equipment*: Three different QKD vendors were present in MadQCI, namely Huawei, ID Quantique and Toshiba. An additional, experimental system, from AIT was also installed remotely in the network as a further demonstration of the integration capabilities of the network. The ID Quantique and Toshiba discrete-variable QKD systems were deployed in both domains. The former ones host, in the same chassis, several blade-like subsystems, such as the quantum devices themselves or optical equipment for the channel adding and dropping. The latter ones were designed to be connected in the middle of a fibre pair that connects a facility, in the nearest point to the ducts. It essentially by-passes every incoming or outgoing optical signal, with some losses, except for its own quantum and signaling channels. The co-located set of Huawei continuous-variable QKD systems [6] rely on external optical equipment, partially shared with the ID Quantique systems and partially standard one but provided by the vendor.

It should be noted that QKD technology is currently establishing itself in the market with multiple business models, which conditions their integration. Many manufacturers choose point-to-point solutions, such as HEQA, ID Quantique, QTI, ThinkQuantum or Toshiba in DV-QKD or KEEQuant and LuxQuanta in CV-QKD. Each one shows its specificities; for example, the way the Toshiba systems multiplex channels or the HEQA equipment that integrates a receiver and a transmitter to facilitate the key forwarding. Other ones take advantage of the new QKD techniques to offer alternative competitive advantages, such as, e.g. Q*Bird, which uses systems based on measurement-device-independent QKD to offer a configuration based on a central hub with multiple

emitters arranged in a star configuration. A potential QKD breakthrough will come when miniaturisation in on-chip photonics would enable other form factors, such as small form-factor pluggable (SFP) integrations and, particularly, lower equipment costs.

A separate discussion deserves quantum random number generation systems, the integration of Quside systems was tested remotely at MadQCI. In any case, there are also this type of resources from other manufacturers, such as ID Quantique or Quantum-Industries, with different technical approaches. For quantum networking, there are two main ones; those based on PCI cards for IT systems and rack-mounted solutions. In both cases, the delivered entropy rates are similar.

B. Quantum and classical coexistence and connectivity

This section details the deployments that enable quantum connectivity in each of the links. Note that it will be these QKD links that will enable the provision of the SDN-like end-to-end service that will be explained in the following section IV-C.

This network connectivity is fundamental in QKD since, together with the quantum resources allocated in the optical network, the cryptographic key material has to be securely managed and transported. Thus, there are different components that must co-operate for delivering a quantum-enabled service. However, this co-operation must happen in the trusted scenario required to allow for information-theoretically security. Secure design principles such as economy of mechanism or access control techniques, as L2/L3 slicing, helped to achieve this.

For achieving the quantum and optical integration, both quantum and classical channels were allocated in the DWDM grid using the most suitable equipment in each case as stated so far. However, in MadQCI several coexistence schemes were tested, both for quantum-classical and quantum-quantum

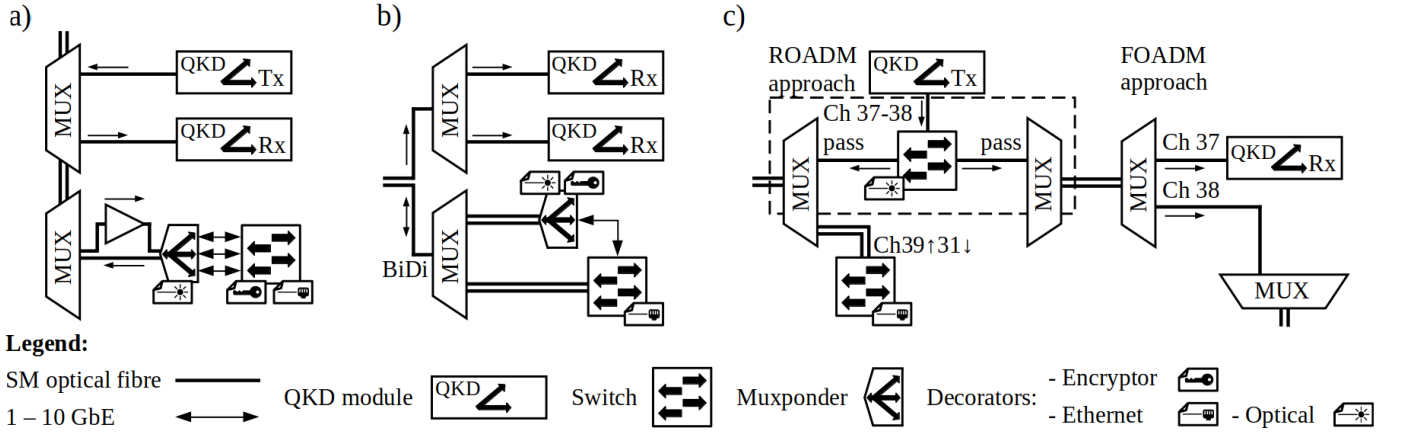

Fig. 7: Main coexistence schemes used in MadQCI. a) Duplex usage of a fibre pair with QKD and classical signals multiplexed in both directions. Several multiplexing stages are used to manage losses, but a single one could be used. The excess loss is compensated with an amplifier at the classical signal input. b) A bidirectional scheme is implemented with a BiDi-multiplexed fibre devoted to classical channels and the other to quantum signals. An additional approach, not depicted here, is using circulators and a unique fibre strand for a bidirectional coexistence [60]. c) Example of a switched QKD network as implemented by Huawei in the co-located domain. On the left, ROADM-type switching is achieved by combining optical fibre switching with multiplexing (enclosed by a dashed line). On the right, FOADM-style switching, where it would be sufficient to transmit on one or the other channel to reach different destinations. Finally, the classical part shows how the wide receive dynamic range of optical transceivers is exploited to pair a couple of transceivers with different channels, which allows better handling of guardbands.

coexistence. Fig. 7 shows the main coexistence schemes implemented in MadQCI.

In the RM domain, the legacy production equipment could be used for aggregation and routing of signals to the terminal equipment. Depending on the case, it was necessary to install ad hoc equipment for the final stages—e.g., a demultiplexer for splitting two quantum coexisting channels—. In addition, some QKD systems operated at 1310 nm instead of the 1550 nm window. Regarding the active components, any classical signal reconditioning was performed after the signal aggregation, e.g., placing the amplifiers near the transceivers. RM operates an IP-based network and the IT systems that supported the use cases were provided with connectivity by the RM network.

In the TID domain, the integration could be more flexible, as the equipment was not shared with other transmissions. In the three TID nodes a higher density of equipment was deployed and coexistence was more intensively tested. Additionally, attack or eavesdropping emulators were installed. Several connectivity technologies were also tested: switch-to-switch Ethernet connectivity using colored transceivers, both in the clear and encrypted (R&S encryptors); OTN-like muxponders by Huawei (OTU4 graming); and the multi-frame optical encryption by ADVA modules. On top of these, network logic was configured to ensure visibility between all QKD, IT and encrypting systems using L2/L3 network devices—e.g., ADVA FSP 150-XG304 or Huawei Quidway S6700 Series—.

Additionally, a border link was implemented between both domains to enable testing cross-domain use cases. An ID Quantique QKD system was deployed there and IP connectivity between the IT systems of both domains was provided in the last stage of the iteration. Note that the co-located domain, namely the Huawei and R&S devices, was deployed in both

networks from the very beginning.

TABLE II: Classical, quantum and encrypted channels that coexisted in the network per link. Distillation and synchronisation channels of the QKD systems are included as classical channels, as well as encrypted channels—e.g., in the Quintín-Quijote link there are 6 classical channels, 2 carrying encrypted information, and 2 quantum channels—. In all cases, the contribution of the co-located domain to the amount of quantum channels is a single quantum channel per link. However, due to the switching capabilities implemented by Huawei, it is possible to find up to four CV-QKD channels in a single fibre [5].

Link	Classical channels	Quantum channels	Encrypted channels
Quintín-Quijote	6	2	2
Quijote-Quirón	4	1	1
Quijote-Quevedo	5	2	1
Quevedo-Quijano	5	1	0
Quijano-Quinto	5	1	0
Distrito-Norte	3	2	1
Distrito-Concepción	4	2	1
Concepción-Norte	6	2	2
Quevedo-Norte	4	2	1

Regarding the co-located domain, Huawei implemented a switched QKD network [5]. The objective was to use transmitters and receivers between any two nodes in the network as needed, allowing for a lower number of modules to be installed. In addition, this approach makes it possible to avoid the need for trusted nodes in relatively low-loss scenarios, such as metropolitan or access networks with limited reach. For this purpose, a design closer to the ROADM style was followed.

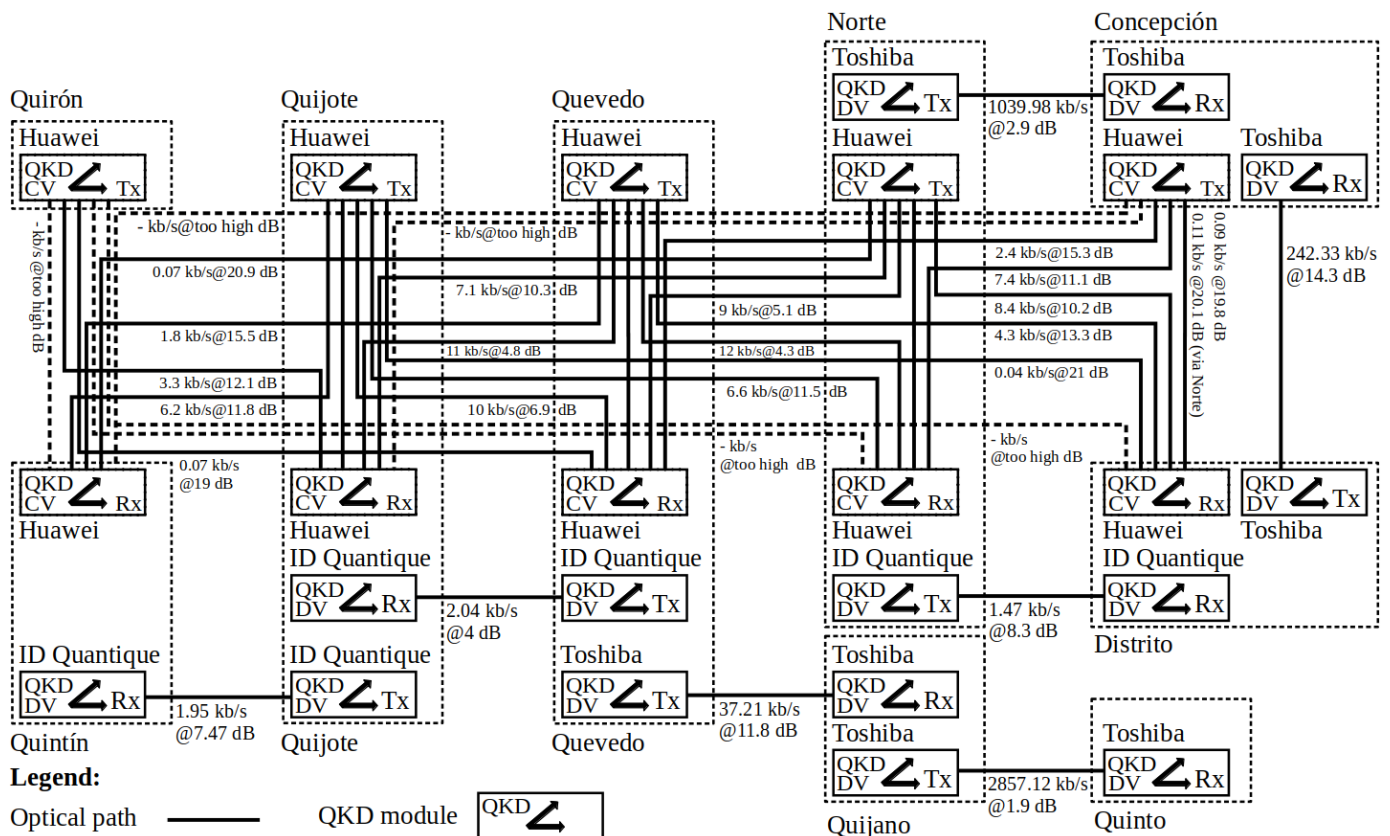

Fig. 8: Circuit diagram with the possible connectivity between the QKD modules in the network. Between each pair of nodes, all circuits are achieved using a single pair of optical fibres—and mostly the same optical equipment—including both the quantum and the classical signals. Both 1) the point-to-point connectivity of the ID Quantique and Toshiba systems and 2) the switched connectivity achieved by the Huawei systems in the co-located domain are shown. This last set of circuits is shown in the upper half and the best performing connectivity has been chosen from the possibilities—systems can broadcast on several channels, so different performances are obtained on the same path. See [5] for more detail—. Each circuit shown, together with the generated key rate, can be exploited by the SDN-like operation and management system as explained in the IV-C section.

Each node was equipped with a fibre optic switch between the fixed optical multiplexers which, in this case, allowed channels 34, 37 and 38 to pass through. This performance of the fixed multiplexers combined with that of the fibre optic switches allows to achieve a cross-connection comparable to that of a network based on ROADMs but without the amplification typical of the WSSs. In addition, the used CV-QKD systems could tune their lasers to any DWDM channel, so any connection could be established if a sufficiently low-loss optical path was available and, at the nodes in the path, any of the three channels was not being used by another connection.

As a result, this co-located domain was able to test a total of 34 possible direct QKD link combinations between the 10 CV-QKD modules installed at 7 nodes.

As a first metric of this integration, the number of classical, encrypted and quantum channels in each of the network links is shown in Table II. Achieving this coexistence is an outcome in itself and is therefore discussed in more detail in the section V.

More relevant to this discussion is the connectivity achieved

in the network, given that it was achieved with both point-to-point links and a switched approach. Figure 8 shows that connectivity and the achieved keyrate. It is relevant to note how the performance of the network must be evaluated according to the design objective. The point-to-point approach may perform better in terms of generated keyrate, while the switched approach would have worse numbers. However, if the design intention was to maximise connectivity between QKD modules, to satisfy certain requirements or operate the network in other manners, the switched approach achieves higher connectivity. Other performances can be evaluated on a case-by-case basis, such as end-to-end service latency. In all cases, this connectivity and generated key will be available to the operation and management system described in the next section to provide the enhanced end-to-end quantum services.

C. Operation, administration and management

In MadQCI, several operation, administration and management (OAM) mechanisms coexisted and were tested. Relevant to this paper is the software-defined management and operation based on ETSI GS QKD standards implemented at

UPM, named SD-QKD Stack here. It is based on the approach explained in section III-D and depicted in Fig. 3. However, there were also some QKD vendor-specific key and network management systems deployed, as well as the management systems of the classical resources.

The SD-QKD Stack enabled the end-to-end quantum services by consuming the QKD keys generated by the links described in the previous section. It is composed of the SDN controller, the set of its agents at the trusted nodes and a set of local key management systems (LKMS) to perform the key management and forwarding tasks, according to the ETSI GS QKD 015 specification. This system therefore implements both key management and networking functionalities. Thus, a joint management of both network and cryptographic key resources was achieved, and a QoS-driven service as specified in ETSI GS QKD 004 could be provided [4].

It operates as follows. First, when a service is requested via the ETSI GS QKD 004 interface at two endpoints—or using the ETSI GS QKD 014 ones—the agents at each node collect the necessary information and relay it to the controller, that decided which settings are suitable in each case. Then, it commands the agents to configure the resources of each node, both the LKMS and the QKD systems, to provide the service. The needed keys generated by the QKD systems on each link of the calculated path are then collected, independently of their manufacturer, and managed by each LKMS. As the latter component include and invokes the FM of each node, it consumes the keys to perform the key forwarding along all the required hops in a vendor agnostic way.

Regarding the classical resources, in general, the optical and connectivity infrastructure was manually or automatically managed and operated using the regular techniques in each domain. This included methods such as configuring the devices via command-line interface, using vendor-specific controllers or setting the configuration remotely.

In an ideal approach, this operation and management is combined with that of the QKD resources. Specifically, the ETSI GS QKD 015 specification defines some optical-networking related fields in its data model, thereby enabling integrated software-defined control. For instance, the SDN controller is able to configure the set of SDN agents the required wavelength and expected attenuation in each hop, to configure these requirements in the SDN-aware devices, both optical and QKD. This demonstrates network programmability that SDN promotes, since the optical-networking requirements may arise from the quality of service requested by a subscriber using the ETSI GS QKD 004 interface, together with all other connectivity and key management requirements.

However, each system has a different degree of maturity, so such integration is an ongoing task and only specific experiments have been performed, as the following section V explains. Another approach is using other interoperability mechanisms, such as the optical-quantum orchestration promoted by the ETSI-QKD-GS-018 specification, that it is also an ongoing task.

V. PERFORMANCE

This section details some of the most relevant results, especially with regard to coexistence and integration with optical networks in production.

1) *General overview:* In general terms, the installation and connection tasks were successful in every domain and had far exceeded the objectives of the associated research projects.

All designs were successfully deployed and only a few minor issues related to configurations or malfunctions of different equipment had to be resolved. Regarding the configuration, the usual complexity of any network deployment was faced, such as managing the network addresses of each device or configuring the keys or certificates for TLS-based connections. The most usual malfunction issues were related to the information systems attached to the network and QKD equipment, both those hosting the SDN software and those that run the key management systems of each vendor: permission and log management, software maintenance, hardware malfunctions... There was also a complete migration of a node to another installation—Almagro to Distrito site—, precisely because it was a production central office.

2) *Quantum and classical coexistence:* Regarding the co-propagation of quantum and classical signals, two examples are highlighted in this work. The most complex nodal schemes can be found in the Appendix .

The first one is shown in Fig. 9 and represents the performance of the link between Quijote and Quevedo nodes, in which two QKD links coexisted with classical data channels, both encrypted and in the clear—only the equipment supporting this link is showed—. The Huawei continuous-variable QKD link operated in the C band—channel 37 or 38 depending on the established link— while the ID Quantique discrete-variable QKD link was in the O band. The quantum-distributed key in both cases was delivered to the the SD-QKD Stack, to forward other key material and support the consuming applications. In this node, an Ethernet R&S encrypting device was installed, which is an example of these applications.

The other highlighted example includes subscribing channels. It is depicted in Fig. 10 and shows the performance of the Quintín-Quijote link. Again, only the devices which transmitted or received signals from that specific link are depicted. However, due to the switching capabilities of the co-located CV-QKD devices, it could exist quantum signals bypassing through the node. This link used a multiplexer for aggregating the signaling from two QKD links, Huawei and ID Quantique, both operating in C band—channels 34 for the DV link and 37 or 38 for the CV link—. In other MadQCI links, the Toshiba discrete-variable QKD systems operated at C band while the ID Quantique ones at both O and C bands—channel 32 the one not depicted—. For multiplexing the classical channels, a bidirectional multiplexed was installed, and supported the signaling channels of the QKD systems, the ciphered channels of R&S and ADVA encryptors and other RM third-party channels.

These are two examples of how the network was capable of delivering quantum-distributed keys in any link of the network while supporting third party communications in some links.

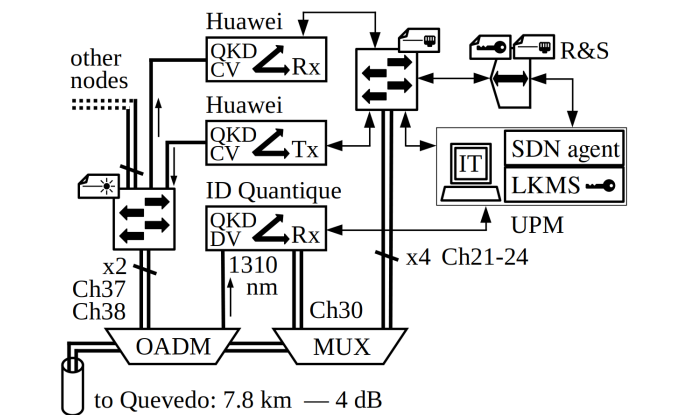

(a) Coexistence scheme that illuminates the Quijote-Quevedo link. It is based on the aggregation of the quantum and classical channels by means of two multiplexers in cascade, which minimises the optical losses of the former. The legend is the same as the one used in Fig. 7

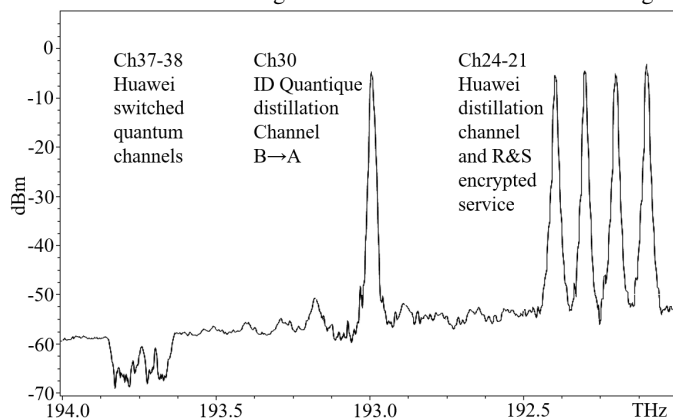

(c) Spectrum of one line outgoing from Quijote to Quevedo.

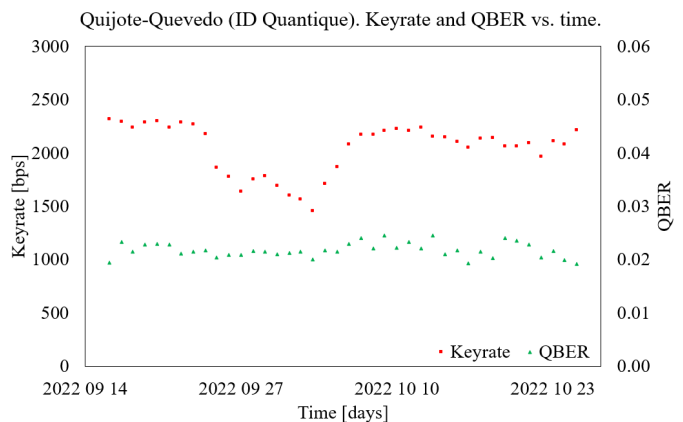

(b) QBER and keyrate of the ID Quantique QKD system installed in Quijote-Quevedo.

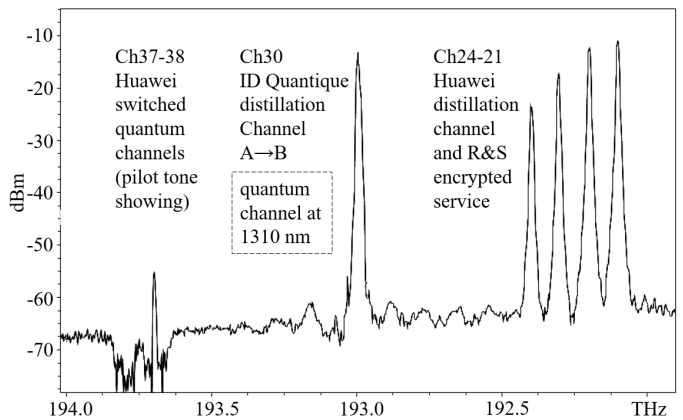

(d) Spectrum of the same line ingoing to Quijote from Quevedo.

Fig. 9: Coexistence in the Quijote-Quevedo link, outfitted with a Huawei CV-QKD link and a ID Quantique DV-QKD link.

For supporting QKD, both quantum and classical channels co-propagated over the network, including distillation and synchronisation channels and data channels for the uses cases. The SD-QKD Stack enabled the end-to-end connectivity, as showed in the following section.

3) *Management, administration and operation:* The operation and management of the quantum network resources and cryptographic key was performed by the SD-QKD Stack based on ETSI GS QKD standards described in section IV-C. The combined operation of the controller and the sets of agents and LKMS allowed the available resources to be operated in a holistic and end-to-end approach. This approach enabled different forwarding techniques, such as using path diversity—i.e. feeding a QKD service with several key streams—or combining keys from different vendors in each hop to provide a vendor-independent service.

Also, using the same approach, other quantum-enabled services have been trialed, such as quantum oblivious key distribution [9, 61] and quantum digital signature [62]. Of interest for this work is the first case, where some CV-QKD in the co-located domain were configured to deliver the raw key, without post-processing. Other DV-QKD still delivered symmetric distilled key. Using these two resources, key material suitable

for quantum oblivious transfer could be obtained. This is an example of the SDN-aware interoperability needed to perform the end-to-end service. The SD-QKD Stack was modified to provide this service using the same software components and, as far as possible, the same standard interfaces. When not, the syntax of the SDN models was overloaded in order to contain the new configurations. Also, the configuration of operating parameters, such as wavelength, was trialed in Huawei CV-QKD systems using the QuAM/QuAI novel technology [63], so that the switching capabilities in the co-located domain could be configured using the same SD-QKD Stack.

VI. CONCLUSION AND FUTURE WORK

The MadQCI testbed not only addressed the challenge of installing 26 QKD multi-vendor modules in coexistence with classical equipment and communications, at 9 sites and 130 km of optical fibres. It has also addressed some high-level issues needed for real-world quantum networking such as the joint operation and management of classical and quantum resources; the integration in production sites of network operators and the fulfilment of their needs; the standardisation; or the quality assurance of the quantum-enhanced services provided.

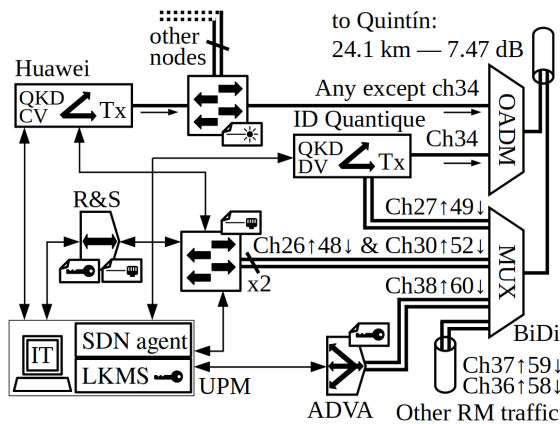

(a) Coexistence scheme that illuminates the Quijote-Quintín link. It is based on using one strand for classical signals, with a bidirectional multiplier, and the other one for quantum signals. The legend is the same as the one used in Fig. 7

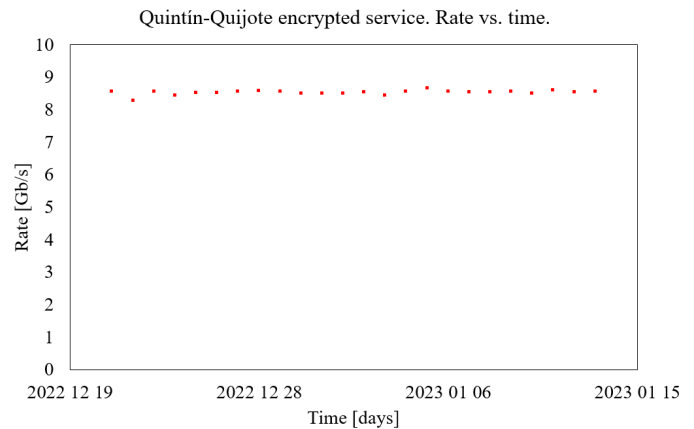

(b) Performance of the L1 encryption by ADVA measured with Iperf tool. In theory, the cipher fills the frames with exactly 10 GbE of information for security, but this is not reflected in the host-to-host measurements due to the peculiarities of the connection, such as headers or TCP retransmissions.

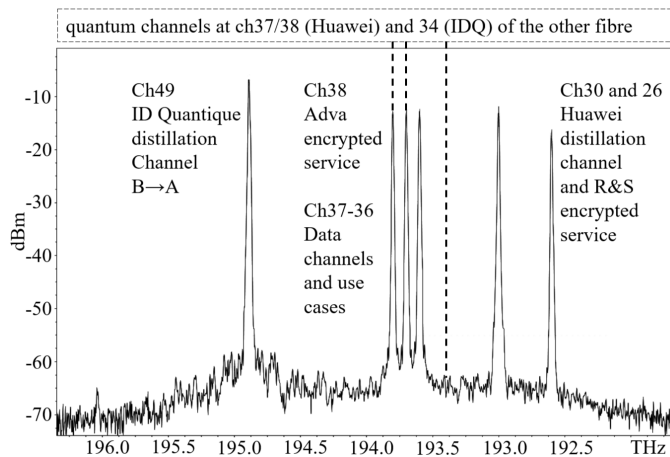

(c) Spectrum of one line outgoing from Quijote to Quintín. In dashed line, the position of the quantum channels at the other fibre of the BiDi multiplexer for illustrative purposes (in this link there is no quantum and classical coexistence).

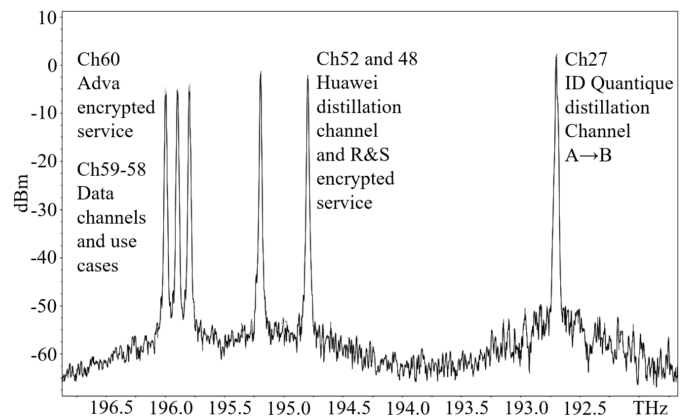

(d) Spectrum of the same line ingoing to Quijote from Quintín.

Fig. 10: Coexistence in the Quijote-Quintín link, outfitted with Huawei CV-QKD and a ID Quantique DV-QKD links, both at C band. The spectrum shows the fibre dedicated to the classical data channels, both encrypted (L1 by ADVA and L2 by R&S) and in the clear. Some of the latest are RM third-party channels.

In this way, it has been possible to present the results as a blueprint for large-scale quantum network deployments. The fundamentals of optical networking and quantum communications to support this goal have also been discussed. It has been important to characterise the networks in production, taking into account their complexity beyond the most basic components.

Indeed, MadQCI was deployed in a multi-domain scenario, with the support of REDIMadrid and Telefónica Innovación Digital. A multi-vendor quantum network—ID Quantique, Huawei, Toshiba, R&S and ADVA manufacturers—was installed with coexistence in production premises and real traffic examples. Several quantum and classical coexistence approaches were tested, ranging from more straightforward approaches to the testing of a switched QKD network. In all cases, the premises, infrastructure elements, classical equip-

ment and information systems were industrial and standard solutions, suitable for deployment in production sites. Firmware updates were needed to take the QKD-generated keys into the encryptors. The performance of two of these approaches has been presented, demonstrating their feasibility for larger deployments.

The quantum connectivity achieved on each link has allowed to show how the SDN operation and management approach can be used to extend the performance to end-to-end quantum-enhanced services. The SD-QKD Stack enabled the testing of a large number of use cases. This software implemented several ETSI-QKD standards, ensuring that it is a valid solution for deployments with a more ambitious scope. It is based on a centralised operation and management of resources through a logically centralized controller and a set of agents at each node, as well as of LKMS modules. Not only encryption ap-

plications have been supported, but also other less proliferated primitives, such as, e.g., oblivious transfer.

MadQCI, aims to be the reference instance in the deployment of other QCI and the pan-European quantum communication infrastructure EuroQCI. In fact, this network is now starting a new iteration thanks to investments of the Quantum Flagship and Digital Europe Programme, as well as the MADQuantum-CM project [64], financed by the Recovery and Resilience Facility funds managed by Spain. Design and procurement is underway and details are being finalised for collaboration with various partners to promote higher value-added use cases, including those involving the satellite segment.

APPENDIX A SCHEMES

This appendix gathers the most relevant node diagrams, which apply the described approach. The nodes not depicted do not contain additional relevant details and are the mirror image of the equipment that illuminates the fibre linking them. The legend used in figure 11 is the same for figures 12, 13, 14 and 15.

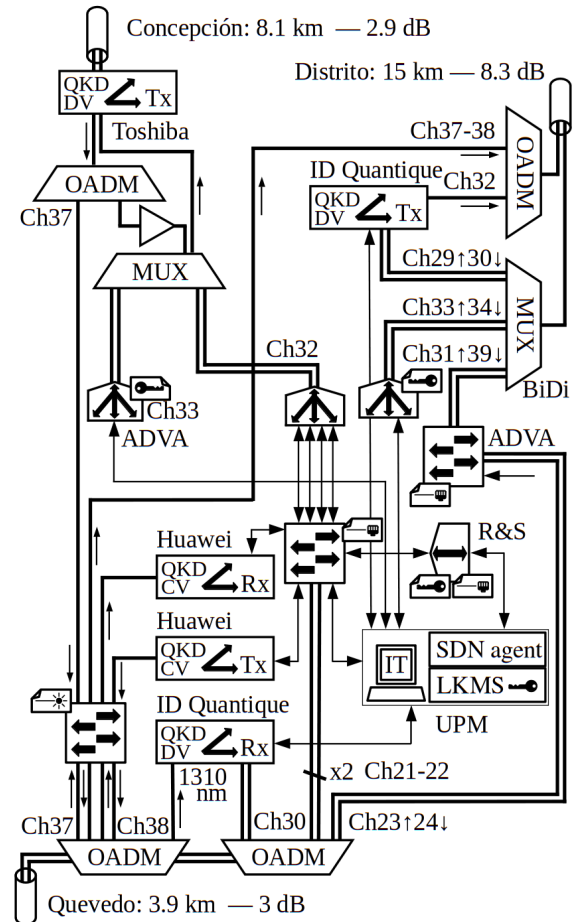

Legend:

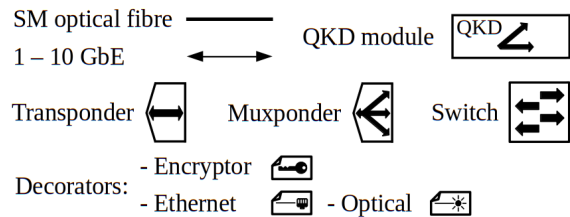

Fig. 11: Layout in Norte node.

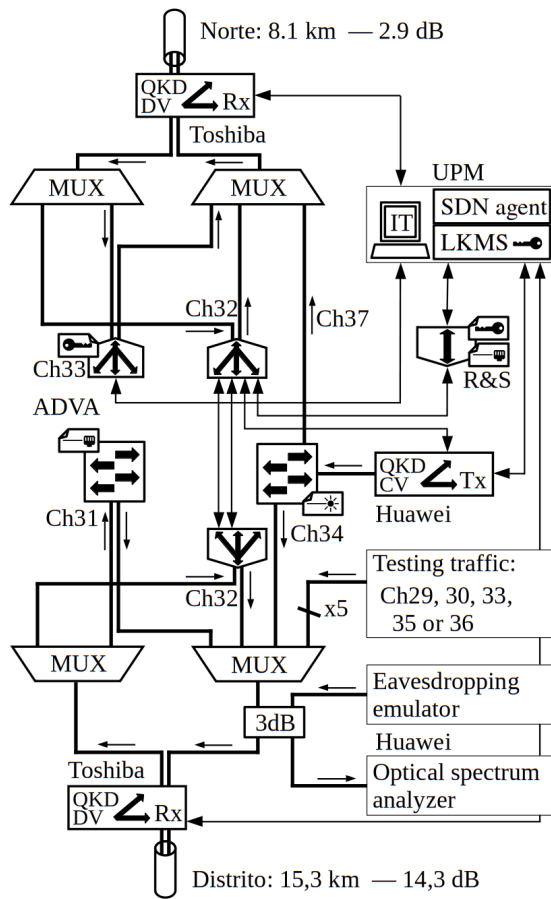

Fig. 12: Layout in Concepción node.

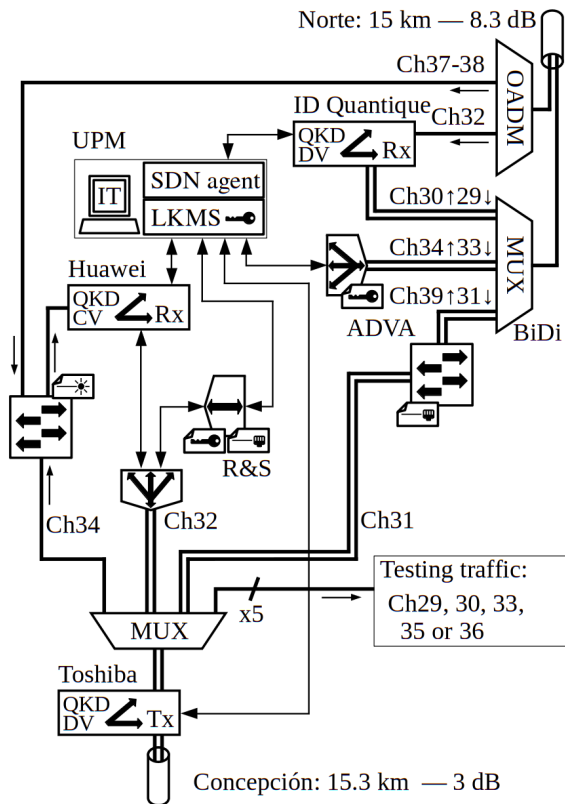

Fig. 13: Layout in Distrito node.

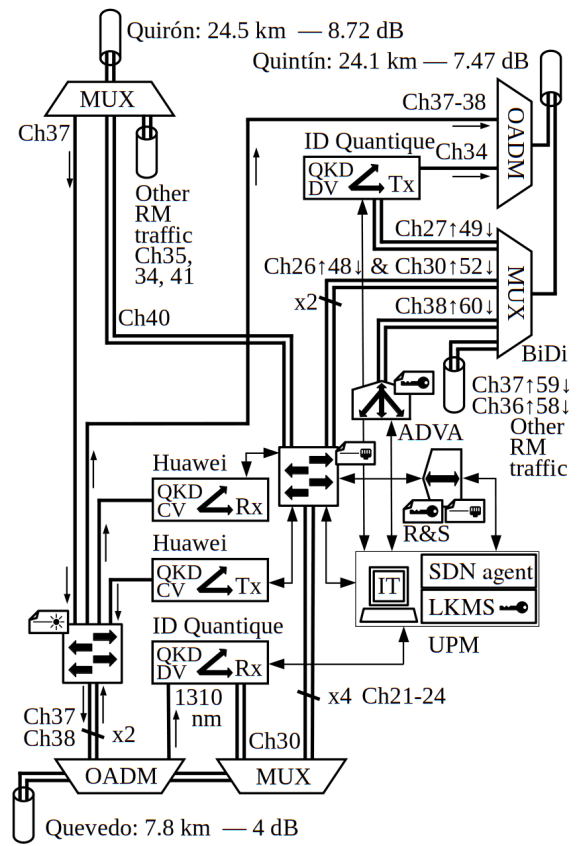

Fig. 14: Layout in Quijote node.

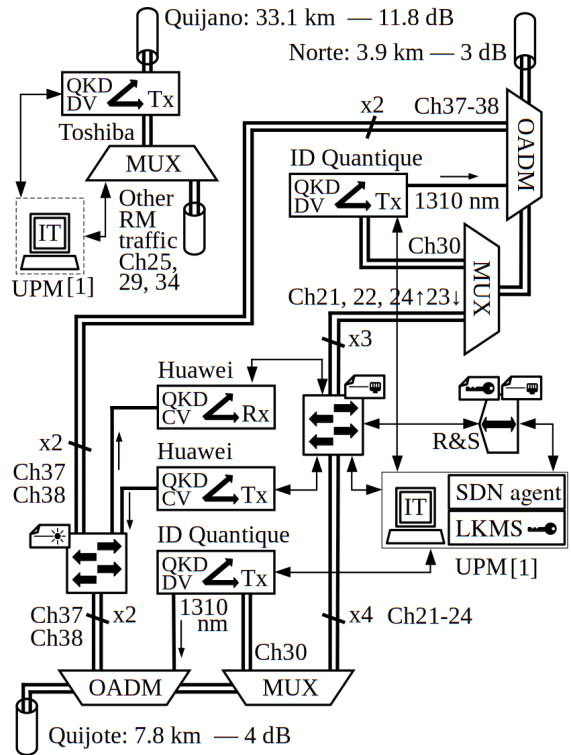

Fig. 15: Layout in Quevedo node.

ACKNOWLEDGMENTS

The authors would like to thank projects MADQuantum-CM, funded by Comunidad de Madrid (Programa de Acciones Complementarias) and by the Recovery, Transformation and Resilience Plan—Funded by the European Union—(NextGenerationEU, PRTR-C17.I1); the EU Horizon Europe project “Quantum Security Networks Partnership” (QSNP), grant 101114043; and EuroQCI-Spain, DEP grant 101091638.

REFERENCES

- [1] N. Gisin, G. Ribordy, W. Tittel, and H. Zbinden, “Quantum cryptography,” *Rev. Mod. Phys.*, vol. 74, pp. 145–195, Mar 2002. [Online]. Available: <https://link.aps.org/doi/10.1103/RevModPhys.74.145>
- [2] V. Martin, J. Martinez-Mateo, and M. Peev, “Introduction to quantum key distribution,” in *Wiley Encyclopedia of Electrical and Electronics Engineering*, J. G. Webster, Ed. John Wiley & Sons, 2017.
- [3] H.-J. Briegel, W. Dür, J. I. Cirac, and P. Zoller, “Quantum repeaters: The role of imperfect local operations in quantum communication,” *Phys. Rev. Lett.*, vol. 81, pp. 5932–5935, Dec 1998. [Online]. Available: <https://link.aps.org/doi/10.1103/PhysRevLett.81.5932>
- [4] V. Martin, J. P. Brito, L. Ortíz, R. B. Méndez, J. S. Buruaga, R. J. Vicente, A. Sebastián-Lombrana, D. Rincón, F. Pérez, C. Sánchez, M. Peev, H. H. Brunner, F. Fung, A. Poppe, F. Fröwis, A. J. Shields, R. I. Woodward, H. Griesser, S. Roehrich, F. de la Iglesia, C. Abellán, M. Hentschel, J. M. Rivas-Moscoso, A. Pastor-Perales, J. Folgueira, and D. López, “Madqci: a heterogeneous and scalable sdn-qkd network deployed in production facilities,” *npj Quantum Information*, vol. 10, no. 1, p. 80, Sep 2024. [Online]. Available: <https://doi.org/10.1038/s41534-024-00873-2>
- [5] H. H. Brunner, C.-H. F. Fung, M. Peev, R. B. Méndez, L. Ortíz, J. P. Brito, V. Martín, J. M. Rivas-Moscoso, F. Jiménez, A. A. Pastor, and et al., “Demonstration of a switched cv-qkd network - epj quantum technology,” Sep 2023. [Online]. Available: <https://epjquantumtechnology.springeropen.com/articles/10.1140/epjqt/s40507-023-00194-x>
- [6] H. H. Brunner, L. C. Comandar, F. Karinou, S. Bettelli, D. Hillerkuss, F. Fung, D. Wang, S. Mikroulis, Q. Yi, M. Kuschnerov, A. Poppe, C. Xie, and M. Peev, “A low-complexity heterodyne cv-qkd architecture,” in *2017 19th International Conference on Transparent Optical Networks (ICTON)*, 2017, pp. 1–4.
- [7] D. Kreutz, F. Ramos, P. Verissimo, C. Esteve Rothenberg, S. Azodolmoly, and S. Uhlig, “Software-defined networking: A comprehensive survey,” *ArXiv e-prints*, vol. 103, 06 2014.
- [8] “Openqkd project website,” 2024. [Online]. Available: <https://openqkd.eu/>
- [9] A. N. Pinto, M. B. Santos, N. A. Silva, N. J. Muga, and P. Mateus, “Oblivious keys for secure multiparty computation obtained from a cv-qkd,” in *2023 23rd International Conference on Transparent Optical Networks (ICTON)*, 2023, pp. 1–4.
- [10] R. B. Méndez, J. P. Brito, L. Ortíz, and V. Martín, “Ipsec usage in madqci during 2018-2022,” *Pending*, vol. pending, no. pending, pending.
- [11] J. S. Buruaga, H. H. Brunner, F. Fung, M. Peev, A. Pastor, D. R. López, L. Ortíz, V. Martín, and J. P. Brito, “Vpn protection with qkd-derived keys using standard interfaces,” in *2023 23rd International Conference on Transparent Optical Networks (ICTON)*, 2023, pp. 1–4.
- [12] C. Elliott, D. Pearson, and G. Troxel, “Quantum cryptography in practice,” in *Proceedings of the 2003 Conference on Applications, Technologies, Architectures, and Protocols for Computer Communications*, ser. SIGCOMM '03. New York, NY, USA: Association for Computing Machinery, 2003, p. 227–238. [Online]. Available: <https://doi.org/10.1145/863955.863982>
- [13] M. Peev, A. Poppe, O. Maurhart, T. Lorunser, T. Langer, and C. Pacher, “The secoqc quantum key distribution network in vienna,” in *2009 35th European Conference on Optical Communication*, 2009, pp. 1–4.
- [14] M. Sasaki, M. Fujiwara, H. Ishizuka, W. Klaus, K. Wakui, M. Takeoka, S. Miki, T. Yamashita, Z. Wang, A. Tanaka, and et al., “Field test of quantum key distribution in the tokyo qkd network,” *Optics Express*, vol. 19, no. 11, p. 10387, May 2011. [Online]. Available: <http://dx.doi.org/10.1364/OE.19.010387>
- [15] D. Lanco, J. Martinez, D. Elkouss, M. Soto, and V. Martin, “Qkd in standard optical telecommunications networks,” in *Quantum Communication and Quantum Networking*, A. Sergienko, S. Pascasio, and P. Villoresi, Eds. Berlin, Heidelberg: Springer Berlin Heidelberg, 2010, pp. 142–149.
- [16] T.-Y. Chen, J. Wang, H. Liang, W.-Y. Liu, Y. Liu, X. Jiang, Y. Wang, X. Wan, W.-Q. Cai, L. Ju, L.-K. Chen, L.-J. Wang, Y. Gao, K. Chen, C.-Z. Peng, Z.-B. Chen, and J.-W. Pan, “Metropolitan all-pass and inter-city quantum communication network,” *Opt. Express*, vol. 18, no. 26, pp. 27217–27225, Dec 2010. [Online]. Available: <https://opg.optica.org/oe/abstract.cfm?URI=oe-18-26-27217>
- [17] T. E. Chapuran, P. Toliver, N. A. Peters, J. Jackel, M. S. Goodman, R. J. Runser, S. R. McNow, N. Dallmann, R. J. Hughes, K. P. McCabe, J. E. Nordholt, C. G. Peterson, K. T. Tyagi, L. Mercer, and H. Dardy, “Optical networking for quantum key distribution and quantum communications,” *New Journal of Physics*, vol. 11, no. 10, p. 105001, oct 2009. [Online]. Available: <https://dx.doi.org/10.1088/1367-2630/11/10/105001>
- [18] A. Bahrami, A. Lord, and T. Spiller, “Quantum key distribution integration with optical dense wavelength division multiplexing: a review,” *IET Quantum Communication*, vol. 1, no. 1, pp. 9–15, 2020. [Online]. Available: <https://ietresearch.onlinelibrary.wiley.com/doi/abs/10.1049/iet-qt.2019.0005>
- [19] A. Ciurana, J. Martínez-Mateo, M. Peev, A. Poppe, N. Walenta, H. Zbinden, and V. Martín, “Quantum metropolitan optical network based on wavelength division multiplexing,” *Opt. Express*, vol. 22, no. 2, pp. 1576–1593, Jan 2014. [Online]. Available: <http://www.osapublishing.org/oe/abstract.cfm?URI=oe-22-2-1576>
- [20] Y. Cao, Y. Zhao, Y. Wu, X. Yu, and J. Zhang, “Time-scheduled quantum key distribution (qkd) over wdm networks,” *Journal of Lightwave Technology*, vol. 36, no. 16, pp. 3382–3395, 2018.
- [21] B.-X. Wang, S.-B. Tang, Y. Mao, W. Xu, M. Cheng, J. Zhang, T.-Y. Chen, and J.-W. Pan, “Practical quantum access network over a 10 gbit/s ethernet passive optical network,” *Opt. Express*, vol. 29, no. 23, pp. 38582–38590, Nov 2021. [Online]. Available: <https://opg.optica.org/oe/abstract.cfm?URI=oe-29-23-38582>
- [22] A. Ciurana, V. Martín, J. Martínez Mateo, B. Schrenk, M. Peev, and A. Poppe, “Entanglement distribution in optical networks,” *IEEE Journal of Selected Topics in Quantum Electronics*, vol. 21, 09 2014.
- [23] A. Aguado, V. Martín, D. Lopez, M. Peev, J. Martinez-Mateo, J. Rosales, F. de la Iglesia, M. Gomez, E. Hugues Salas, A. Lord, R. Nejabati, and D. Simeonidou, “Quantum-aware software defined networks,” in *6th International Conference on Quantum Cryptography (QCRYPT 2016)*, QCrypt, Sep. 2016, 42nd European Conference on Optical Communication, ECOC 2016 : 42nd European Conference and Exhibition on Optical Communication ; Conference date: 18-09-2016 Through 22-09-2016.
- [24] V. Martín, A. Aguado, J. P. Brito, A. L. Sanz, P. Salas, D. R. López, V. López, A. Pastor-Perales, A. Poppe, and M. Peev, “Quantum aware sdn nodes in the madrid quantum network,” in *2019 21st International Conference on Transparent Optical Networks (ICTON)*, 2019, pp. 1–4.
- [25] “Industry specification group (isg) on quantum key distribution (qkd),” 2024. [Online]. Available: <https://www.etsi.org/committee/qkd>
- [26] Q. Zhang, F. Xu, L. Li, N.-L. Liu, and J.-W. Pan, “Quantum information research in china,” *Quantum Science and Technology*, vol. 4, no. 4, p. 040503, nov 2019. [Online]. Available: <https://doi.org/10.1088/2058-9565/ab4bea>
- [27] Wei Qi, “A brief introduction to the latest progress of china’s qkd industry. 9th ETSI/IQC Quantum Safe Cryptography Event, 13-15.02.2023.” [Online]. Available: https://docbox.etsi.org/Workshop/2023/02_QuantumSafeCryptography/TechnicalTrack/Worldtour/CASQuantumNetwork_Qi.pdf
- [28] Y.-A. Chen, Q. Zhang, T.-Y. Chen, W.-Q. Cai, S.-K. Liao, J. Zhang, K. Chen, J. Yin, J.-G. Ren, Z. Chen, S.-L. Han, Q. Yu, K. Liang, F. Zhou, X. Yuan, M.-S. Zhao, T.-Y. Wang, X. Jiang, L. Zhang, W.-Y. Liu, Y. Li, Q. Shen, Y. Cao, C.-Y. Lu, R. Shu, J.-Y. Wang, L. Li, N.-L. Liu, F. Xu, X.-B. Wang, C.-Z. Peng, and J.-W. Pan, “An integrated space-to-ground quantum communication network over 4,600 kilometres,” *Nature*, vol. 589, no. 7841, pp. 214–219, Jan 2021. [Online]. Available: <https://doi.org/10.1038/s41586-020-03093-8>
- [29] T.-Y. Chen, X. Jiang, S.-B. Tang, L. Zhou, X. Yuan, H. Zhou, J. Wang, Y. Liu, L.-K. Chen, W.-Y. Liu, H.-F. Zhang, K. Cui, H. Liang, X.-G. Li, Y. Mao, L.-J. Wang, S.-B. Feng, Q. Chen, Q. Zhang, L. Li, N.-L. Liu, C.-Z. Peng, X. Ma, Y. Zhao, and J.-W. Pan, “Implementation of a 46-node quantum metropolitan area network,” *npj Quantum Information*, vol. 7, no. 1, p. 134, Sep 2021. [Online]. Available: <https://doi.org/10.1038/s41534-021-00474-3>
- [30] O. Alia, R. S. Tessinari, E. Hugues-Salas, G. T. Kanellos, R. Nejabati, and D. Simeonidou, “Dynamic dv-qkd networking in trusted-node-free

- software-defined optical networks,” *Journal of Lightwave Technology*, vol. 40, no. 17, p. 5816–5824, Sep. 2022. [Online]. Available: <https://dx.doi.org/10.1109/JLT.2022.3183962>
- [31] “Quantum flagship website,” 2024. [Online]. Available: <https://qt.eu/>
- [32] “The digital europe programme website,” 2024. [Online]. Available: <https://digital-strategy.ec.europa.eu/en/activities/digital-programme>
- [33] “Civiq project website,” 2024. [Online]. Available: <https://civiquantum.eu/>
- [34] “Qsnp project website,” 2024. [Online]. Available: <https://qsnp.eu/>
- [35] “National euroqci,” 2024. [Online]. Available: <https://petrus-euroqci.eu/national-euroqci/>
- [36] Y. Cao, Y. Zhao, Q. Wang, J. Zhang, S. X. Ng, and L. Hanzo, “The evolution of quantum key distribution networks: On the road to the qinternet,” *IEEE Communications Surveys & Tutorials*, vol. 24, no. 2, pp. 839–894, 2022.
- [37] P. Kómár, E. M. Kessler, M. Bishof, L. Jiang, A. S. Sørensen, J. Ye, and M. D. Lukin, “A quantum network of clocks,” *Nature Physics*, vol. 10, no. 8, pp. 582–587, Aug. 2014.
- [38] R. Ramaswami and K. N. Sivarajan, *Optical Networks: A Practical Perspective*. San Francisco, CA, USA: Morgan Kaufmann Publishers Inc., 1998.
- [39] R. Renner, N. Gisin, and B. Kraus, “Information-theoretic security proof for quantum-key-distribution protocols,” *Phys. Rev. A*, vol. 72, p. 012332, Jul 2005. [Online]. Available: <https://link.aps.org/doi/10.1103/PhysRevA.72.012332>
- [40] V. Mavroicidis, K. Vishi, M. D. Zych, and A. Jøsang, “The impact of quantum computing on present cryptography,” *International Journal of Advanced Computer Science and Applications*, vol. 9, no. 3, 2018. [Online]. Available: <http://dx.doi.org/10.14569/IJACSA.2018.090354>
- [41] G. S. Vernam, “Cipher printing telegraph systems for secret wire and radio telegraphic communications,” *Transactions of the American Institute of Electrical Engineers*, vol. XLV, pp. 295–301, 1926.
- [42] J. Y. Cho, J.-J. Pedreno-Manresa, S. Patri, A. Sergeev, J.-P. Elbers, H. Griesser, C. White, and A. Lord, “Demonstration of software-defined key management for quantum key distribution network,” in *2021 Optical Fiber Communications Conference and Exhibition (OFC)*, 2021, pp. 1–3.
- [43] M. Fedor, M. L. Schoffstall, J. R. Davin, and D. J. D. Case, “Simple Network Management Protocol (SNMP),” RFC 1157, May 1990. [Online]. Available: <https://www.rfc-editor.org/info/rfc1157>
- [44] M. Casado, M. J. Freedman, J. Pettit, J. Luo, N. McKeown, and S. Shenker, “Ethane Taking control of the enterprise,” in *Proceedings of the 2007 Conference on Applications, Technologies, Architectures, and Protocols for Computer Communications*, ser. SIGCOMM ’07. New York, NY, USA: Association for Computing Machinery, 2007, p. 1–12. [Online]. Available: <https://doi.org/10.1145/1282380.1282382>
- [45] I. S. G. Q. K. Distribution, “Quantum Key Distribution (QKD); Control Interface for Software Defined Networks,” European Telecommunications Standards Institute, Sophia Antipolis, CH, Standard, Apr. 2022.
- [46] —, “Quantum Key Distribution (QKD); Application Interface,” European Telecommunications Standards Institute, Sophia Antipolis, CH, Standard, Aug. 2020.
- [47] —, “Quantum Key Distribution (QKD); Orchestration Interface for Software Defined Networks,” European Telecommunications Standards Institute, Sophia Antipolis, CH, Standard, Apr. 2022.
- [48] V. Martin, M. Peev, J. Brito, L. Ortíz, R. Méndez, R. Vicente, J. Saez-Buruaga, A. S.-L. I, M. García-Cid, J. Faba, J. Setien, P. Salas, C. Escribano, L. Mengual, F. Fung, J. Morales, A. Muñiz, A. Pastor-Perales, and D. Lopez., “Towards large scale qkd networks,” in *2024 24rd International Conference on Transparent Optical Networks (ICTON)*, 2024, pp. 1–5.
- [49] M. Peev *et al.*, “Quantum Key Distribution Network Architectures,” in *2024 International Conference on Quantum Communications, Networking, and Computing (QCNC)*, 7 2024.
- [50] R. Enns, M. Björklund, A. Bierman, and J. Schönwälder, “Network Configuration Protocol (NETCONF),” RFC 6241, Jun. 2011. [Online]. Available: <https://www.rfc-editor.org/info/rfc6241>
- [51] M. Björklund, “YANG - A Data Modeling Language for the Network Configuration Protocol (NETCONF),” RFC 6020, Oct. 2010. [Online]. Available: <https://www.rfc-editor.org/info/rfc6020>
- [52] “Github - opennetworkingfoundation/tapi,” 2024. [Online]. Available: <https://github.com/OpenNetworkingFoundation/TAPI>
- [53] “Open roadm msa - home,” 2024. [Online]. Available: <https://http://openroadm.org/>
- [54] T. Ferreira da Silva, G. B. Xavier, G. P. Temporão, and J. P. von der Weid, “Impact of raman scattered noise from multiple telecom channels on fiber-optic quantum key distribution systems,” *Journal of Lightwave Technology*, vol. 32, no. 13, pp. 2332–2339, 2014.
- [55] P. Toliver, R. J. Runser, T. E. Chapuran, M. S. Goodman, J. Jackel, S. McNown, R. J. Hughes, C. G. Peterson, K. McCabe, J. Nordholt, K. Tyagi, P. Hiskett, and N. Dallman, “Demonstration of 1550 nm qkd with roadm-based dwdm networking and the impact of fiber fwm,” in *2007 Conference on Lasers and Electro-Optics (CLEO)*, 2007, pp. 1–2.
- [56] P. Eraerds, N. Walenta, M. Legré, N. Gisin, and H. Zbinden, “Quantum key distribution and 1 gbps data encryption over a single fibre,” *New Journal of Physics*, vol. 12, no. 6, p. 063027, jun 2010. [Online]. Available: <https://dx.doi.org/10.1088/1367-2630/12/6/063027>
- [57] D. Subacius, A. Zavriyev, and A. Trifonov, “Backscattering limitation for fiber-optic quantum key distribution systems,” *Applied Physics Letters*, vol. 86, no. 1, p. 011103, 12 2004. [Online]. Available: <https://doi.org/10.1063/1.1842862>
- [58] G. B. Xavier, G. V. de Faria, G. P. Temporão, and J. P. von der Weid, “Scattering Effects on QKD Employing Simultaneous Classical and Quantum Channels in Telecom Optical Fibers in the C-band,” *AIP Conference Proceedings*, vol. 1110, no. 1, pp. 327–330, 04 2009. [Online]. Available: <https://doi.org/10.1063/1.3131339>
- [59] N. I. of Standards and Technology, “Recommendation for key management: Part 1 – general,” U.S. Department of Commerce, Washington, D.C., Tech. Rep. NIST SP 800-57 Part 1 Rev. 5, 2020.
- [60] M. Avesani, G. Foletto, M. Padovan, L. Calderaro, C. Agnesi, E. Baz-zani, F. Berra, T. Bertapelle, F. Picciariello, F. B. L. Santagiustina, D. Scalco, A. Scriminich, A. Stanco, F. Vedovato, G. Vallone, and P. Villoresi, “Deployment-ready quantum key distribution over a classical network infrastructure in padua,” *Journal of Lightwave Technology*, vol. 40, no. 6, pp. 1658–1663, 2022.
- [61] A. N. Pinto, L. Ortiz, M. Santos, A. C. Gomes, J. P. Brito, N. J. Muga, N. A. Silva, P. Mateus, and V. Martin, “Quantum enabled private recognition of composite signals in genome and proteins,” in *2020 22nd International Conference on Transparent Optical Networks (ICTON)*, 2020, pp. 1–4.
- [62] M. I. García Cid, D. G. Aguado, L. O. Martín, and V. M. Ayuso, “Simulated multiparty quantum digital signature in cyberspace operations,” in *2023 International Conference on Military Communications and Information Systems (ICMCIS)*, 2023, pp. 1–9.
- [63] R. B. Mendez, J. P. Brito, R. J. Vicente, A. Aguado, A. Pastor, D. Lopez, V. Martin, and V. Lopez, “Quantum abstraction interface: Facilitating integration of qkd devices in sdn networks,” in *2020 22nd International Conference on Transparent Optical Networks (ICTON)*, 2020, pp. 1–4.
- [64] “Madquantum-cm project website,” 2024. [Online]. Available: <https://madqci.es/>

Alberto Sebastián-Lombráña is doctoral candidate at the U. Politécnica de Madrid and predoctoral assistant professor with Dept. LSIIS, E.T.S.I.Inf. He collaborates in the field of Quantum Communications Infrastructures (QCI) with the Quantum Information and Computation Group and the Center of Computational Simulation of that university. Previously, while graduating in Telecommunications Engineering (M.Sc.) at the U. Autónoma de Madrid, he collaborated with the modelling & software engineering research group of the Computer Science Dept. of that university.

Hans H. Brunner is a principal research engineer at the Munich Research Center of Huawei Technologies Duesseldorf GmbH (HWDU). He is the architect and leading engineer of the CV-QKD prototypes developed at HWDU, his research focuses on CV-QKD implementations and networks. Brunner received the B.Sc., Dipl.-Ing. (M.Sc.), and Dr.-Ing. (Ph.D.) degrees in electrical engineering from Technical University of Munich (TUM) in 2005, 2007, and 2016, respectively.

Juan P. Brito is PhD in Computer Science and currently Assistant Professor at Universidad Politécnica de Madrid. He has participated in more than 20 QKD research projects, several of them included in the FET Flagships. On these projects, his research lines have evolved around Quantum Technologies integration into modern telco infrastructures following new network paradigms like Software Defined Networking (SDN) and Network Function Virtualization (NFV). He has over 30 international publications, holds an accepted patent and is a member of the European Telecommunications Standards Institute.

Rubén B. Méndez received his Computer Engineering degree from the University of Las Palmas de Gran Canaria (UPLGC) in 2016 and then his Master's degree in 2021 from the Polytechnic University of Madrid (UPM). He is currently collaborating with the research group on quantum communications at the UPM Center of Computational Simulation where he has developed some publications in recent years. His main areas of interest are related to the insertion of technologies such as QKD in real networks through standards and tools such as SDN in order to update current protocols of classical cryptography, he also studies new ways to introduce QKD in SDN networks in a standard and transparent way for telcos.

Rafael J. Vicente received the Computer Engineer and the Computer Science Degrees from the Universidad Rey Juan Carlos (URJC) in 2018, Master's Degree in Computer Graphics, Games and Virtual Reality from the URJC in 2021 and was admitted in the Ph.D. in Software, Systems and Computing (DSSC) program from the Universidad Politécnica de Madrid (UPM) in 2021. Since 2019, he has been a Research Developer within the Group of Investigation in Quantum Information (GIICC) for the Center of Computational Simulation (CCS) of the UPM. During this period, his research has been focused on the development and implementation of standards to enable the next generation of quantum communication networks, participating in European initiatives and projects such as CIVIQ and OPENQKD. His Ph.D. thesis focuses on the study of Quantum Key Management Systems (QKMS) in Software Defined Networks (SDN) and the acceleration of QKD-assisted cryptographic algorithms.

Jaime S. Buruaga received the B.S degree in Informatic Engineering from the Complutense University of Madrid (UCM), and the M.S. degree in Networking Engineering from the Politecnica University of Madrid (UPM), in 2022. He started his PhD in 2022 in the field of Quantum Communications research group in quantum communications with the Quantum Information and Computation Group and the Center of Computational Simulation (CCS), where he is currently working as a Networking Engineer. His PhD topic is the integration of Quantum Communications in today's cryptographic networks, with several international publications. Currently, his research interest is related to the integration of standards that implement Quantum Key Distribution into current cryptographic protocols.

Laura Ortiz (PhD in Physics, U. Complutense de Madrid) is currently an assistant professor at the U. Politécnica de Madrid. Her research interests covers from topological quantum Computing to quantum metrology with nitrogen vacancies. Her line of research focuses on protocols beyond quantum key distribution. She has gained experience with post-quantum cryptography algorithms recently.

Chi-Hang Fred Fung is a principal scientist at the Munich Research Center of Huawei Technologies Duesseldorf GmbH (HWDU). He is the leading designer of QKD protocols and processes developed at HWDU. His research focuses on QKD security, QKD theory and quantum information and communications.

Montchil Peev studied mathematics and physics at the University of Sofia, Bulgaria. Ph.D. in 1993. Lise-Meitner post-doctoral Fellow at the Vienna University of Technology (1993-95) and at ARCS (resp AIT, 1995-97). Research associate at ARCS until 2010 and then senior scientist and thematic coordinator for QKD. Since 2015 he is senior expert and project leader in the Optical and Quantum Communications Laboratory at the Munich Research Center of Huawei Technologies Duesseldorf GmbH. M. Peev led the development of a QKD network prototype in the European project SECOQC (2004-2008), and coordinated the effort of the Huawei Munich Group in the SDN-QKD demonstration of Telefonica-UPM-Huawei in Madrid (2018).

José M. Rivas-Moscoso obtained his PhD in Physics from the University of Santiago de Compostela, Spain, in 2004. From 2004 to 2010 he worked as a postdoctoral researcher at the Cambridge University Engineering Department, UK, and the School of Telecommunication of the Technical University of Madrid, Spain. In 2011 he joined the Network Core Evolution group at Telefónica I+D, Spain, focusing on beyond-100G transport technologies, and in 2014 he started his collaboration with the Network and Optical Communications group at AIT, Greece, where he investigated elastic optical networks, flexible optical switching and SDM. Since 2017, he has been with Telefónica CTIO, initially as an optical transport network architect and more recently, taking on the role of optical transport innovation expert. His research interests include multiband and SDM transmission, and QKD.

Felipe Jiménez Arribas holds an electronic physics degree from UCM. He joined Telefónica I+D in 1994 on a Ph.D. student scholarship, becoming part of the staff in 1995. He started working on the development of the Telefónica Spain nationwide IP network, and since then has been involved in many projects related to access and core architectures as well as in field trials of advanced fiber technologies. He has also worked on relevant EU projects, like the FP6 MUSE, FP7 Accordance, TREND, Discuss, Idealist and INSPACE projects.

Antonio Pastor is Industrial Engineer from the Carlos III University of Madrid (1999). He joined Telefónica I+D in 1999 working on the design and deployment of different networks worldwide. Since 2006 he has been working as an expert in network security in Telefónica. He is currently the expert responsible for security research in the network transport area in Telefonica Global CTIO Unit. He has participated in many security research programs, holding several security certifications and patents.

Diego R. López joined Telefonica in 2011 as a Senior Technology Expert, and he is currently in charge of the Technology Exploration activities within the GCTIO Unit. Before joining Telefónica he spent some years in the academic sector, dedicated to research on network services, and was appointed member of the High-Level Expert Group on Scientific Data Infrastructures by the European Commission. Diego is currently focused on applied research in network infrastructures, with a special emphasis on data-driven management, new architectures, security, and quantum communications. Diego is an ETSI Fellow and chairs the ETSI ISG ZSM.

Jesús Folgueira is MSc in Telecommunications Engineering from UPM (1994) and MSc in Telecommunication Economics from UNED (2015). He joined Telefónica I+D in 1997. Head of Transport and IP Networks within Telefonica Global CTO unit, he leads Network Planning, Technology and Innovation. He is focused on Optical, Metro & IP Networks, network virtualization (SDN/NFV) and advanced switching. His expertise includes Broadband Access, R&D Management, and network deployment.

Vicente Martín is a Full Professor of Computational Sciences at the Universidad Politécnica de Madrid, where he leads the Research Group on Quantum Information and coordinates the Madrid Quantum Communications Infrastructure. He has contributed to standards in Quantum Key Distribution (QKD) through organizations like ETSI and CEN, where he has been vice-chair and rapporteur in the ISG-QKD and convener in the JTC22. His research focuses on integrating Quantum Communications into telecommunications networks and security infrastructures, pioneering the use of SDN for QKD networks.