

Contracting Self-Similar Groups in Group-Based Cryptography

Delaram Kahrobaei¹, Arsalan Akram Malik², and Dmytro Savchuk²

¹Computer Science and Mathematics Departments, The City University of New York, Queens College, CUNY, The Initiative for the Theoretical Sciences, CUNY Graduate Center, Department of Computer Science, University of York (UK), Department of Computer Science and Engineering, Tandon School of Engineering, New York University, Delaram.Kahrobaei@qc.cuny.edu

²Department of Mathematics and Statistics, University of South Florida, 4202 E Fowler Ave, Tampa, FL 33620-5700, arsalanakram@usf.edu, savchuk@usf.edu

Abstract

We propose self-similar contracting groups as a platform for cryptographic schemes based on simultaneous conjugacy search problem (SCSP). The class of these groups contains extraordinary examples like Grigorchuk group, which is known to be non-linear, thus making some of existing attacks against SCSP inapplicable. The groups in this class admit a natural normal form based on the notion of a nucleus portrait, that plays a key role in our approach. While for some groups in the class the conjugacy search problem has been studied, there are many groups for which no algorithms solving it are known. Moreover, there are some self-similar groups with undecidable conjugacy problem. We discuss benefits and drawbacks of using these groups in group-based cryptography and provide computational analysis of variants of the length-based attack on SCSP for some groups in the class, including Grigorchuk group, Basilica group, and others.

Contents

1	Introduction	2
2	Cryptosystems Based on Variants of the Conjugacy Search Problem in Groups	5
2.1	Commutator key exchange: a.k.a. Anshel-Anshel-Goldfeld (AAG) protocol	5
2.2	Non-commutative Diffie-Hellman: a.k.a. Ko-Lee protocol	6
2.3	Non-commutative ElGamal key-exchange: a.k.a. Kahrobaei-Khan Protocol	6
2.4	Non-commutative digital signature: a.k.a. Kahrobaei-Koupparis DSS	6
3	Automaton Groups	7
3.1	Trees	7
3.2	Automaton and self-similar groups	8

4	Contracting Groups	10
4.1	Basic definitions and properties	11
4.2	Computations with nucleus portraits	13
4.3	An explicit example of AAG key generation using nucleus portraits	14
5	Recovering Words from Nucleus Portraits	18
6	Length-Based Attack	22
6.1	Complexity estimate for the LBA	23
6.2	Length functions for LBA	23
6.2.1	Portrait depth length function	23
6.2.2	Portrait boundary size length function	24
7	Experimental Results for LBA against SCSP in Contracting Groups	24
7.1	Notation for the attack	25
7.1.1	Simultaneous Conjugacy Search Problem (SCSP)	25
7.1.2	Runtime	25
7.1.3	Parameters	26
7.2	The group $\mathbb{G}(\mathcal{A}_{750}) \cong \mathbb{Z} \wr C_2$	26
7.3	The group $\mathbb{G}(\mathcal{A}_{775}) \cong IMG\left(\left(\frac{z-1}{z+1}\right)^2\right) \rtimes C_2$	27
7.4	The group $\mathbb{G}(\mathcal{A}_{2277}) \cong (\mathbb{Z} \times \mathbb{Z}) \rtimes C_2$	28
7.5	The group $\mathbb{G}(\mathcal{A}_{2287}) \cong IMG\left(\frac{z^2+2}{1-z^2}\right)$	28
7.6	The group $IMG(z^2 + i)$	30
7.7	Grigorchuk group \mathcal{G}	31
7.8	Universal Grigorchuk group \mathcal{G}_U	32
7.9	Basilica group $\mathcal{B} \cong IMG(z^2 - 1)$	33

1 Introduction

Group-based cryptography is a relatively new area in post-quantum cryptography that started to develop in 1990's and rapidly grew in the recent 20 years. Several sources covering main developments in the area include [MSU11, DKRH16, KFN23, KFN⁺24].

Among many cryptographic schemes that were proposed based on non-abelian groups, there are several that are based on the complexity of various problems related to conjugacy in groups, such as conjugacy search problem, simultaneous conjugacy search problem, and other problems related to them. The conjugacy decision problem asks whether or not two given elements a, b of a group G are conjugate. The conjugacy search problem (CSP), on the other hand, given two elements a, b of a group G that are conjugate, asks to find at least one $r \in G$ such that $a^r = r^{-1}ar = b$. And the simultaneous conjugacy search problem (SCSP) similarly asks, given two tuples (a_1, a_2, \dots, a_n) and (b_1, b_2, \dots, b_n) of elements in G , such that there is $r \in G$ satisfying $a_i^r = b_i$ for all $1 \leq i \leq n$, to find at least one such r . The first protocol in this family was proposed by Anshel-Anshel-Goldfeld (AAG) commutator key exchange protocol was proposed in [AAG99]. Later Ko, Lee et al in [KLC⁺00] introduced a non-commutative version of Diffie-Hellman key exchange protocol. This was followed by Kahrobaei-Koupparis digital signature scheme [KK12] and Kahrobaei-Khan

non-commutative ElGamal public key encryption scheme [KK06]. All of these schemes are generic protocols that require a choice of an appropriate platform group or a class of groups to operate. For example, the original Ko-Lee and AAG protocols were proposing to use braid groups as platform groups. A generalization of a conjugacy search problem, called the decomposition problem, was used by Shpilrain and Ushakov in [SU06] to construct another key exchange protocol. Other generalizations of AAG and Ko-Lee protocols were recently proposed by Habeeb [Hab23]. However, several cryptanalysis attacks were suggested [KMU14, BZKT18] that showed certain vulnerabilities of the schemes in the case when the group has efficient matrix representations.

Automaton groups have been proposed as platform for some cryptographic protocols with history described in detail in a recent paper [KNR24]. The first protocol of this type was based on Grigorchuk groups [GZ91], although it was shown to be insecure in [Pet03]. In [GG19a], Grigorchuk and Grigoriev suggested some specific families of automaton groups, known as branch groups, as platforms for Anshel-Anshel-Goldfeld key-agreement. Among others, they suggest the aforementioned Grigorchuk group and the Basilica group [GZ02a, BGK⁺08].

In most cases the groups generated by automata possess very peculiar and interesting characteristics. They provide a range of new examples that essentially do not have a simpler description than the one given by automaton. They include groups with properties such as torsion infinite finitely generated, or being of intermediate growth, and thus non-linear by Tits alternative [Tit72]. The class of automaton groups is also very interesting from algorithmic viewpoint. These groups admit effective calculations with group elements as the word problem is decidable (with exponential time complexity in general and polynomial time complexity in the case of contracting groups). However, many standard algorithmic problems are either undecidable or their decidability status is unknown. For example, Šunić and Ventura showed that the conjugacy problem is undecidable [ŠV12] and Gillibert showed that the finiteness of an automaton semigroups is undecidable [Gil14], and so is the order problem [Gil18, BM20].

These algorithmic properties make the class of automaton groups a good candidate for group-based cryptography. Moreover, many automaton groups possess naturally commuting subgroups, which is a requirement for some protocols, such as Ko-Lee key exchange protocol. However, there are some positive results regarding the solutions of conjugacy (search) problem in automaton groups. For example, it was proved that the conjugacy problem in Grigorchuk group \mathcal{G} is decidable by Leonov [Leo98] and Rozhkov [Roz98]. These ideas were used by Grigorchuk and Wilson to construct an algorithm solving the conjugacy problem in the certain class of branch groups [GW00]. Later polynomial time algorithm solving the conjugacy problem in \mathcal{G} was constructed by Lysenok, Myasnikov, and Ushakov [LMU10] and very recently a linear time algorithm was developed by Modi, Seedhom, and Ushakov in [MSU21]. One more large group for which the conjugacy problem is decidable is the group B_d of all bounded automata over a d -letter alphabet [BBSZ13]. This group, as well as the notion of polynomially and exponentially growing automata, was introduced by Sidki [Sid04] who proved that finite automata of polynomial growth do not generate free groups. Note that group B_d is very large and not finitely generated, and the solution of the conjugacy problem in B_d does not yield a solution of this problem in any subgroup of B_d . Additionally, Scuderi, Seekamp, and the third author implemented an effective heuristic attack against SCSP in the case of contracting groups acting on binary tree [SSS24] when the length of the secret conjugator is known. The paper containing the detailed result of this attack is under preparation.

In this paper we study a possibility to use the class of contracting automaton groups for cryptographic protocols based on variants of conjugacy search problem. This class includes many famous

groups, such as Grigorchuk group, Gupta-Sidki group, Basilica group, etc. As mentioned above, it allows for effective calculations with group elements since there is a polynomial time algorithm solving the word problem that goes back to calculations of Grigorchuk [Gri84] and whose complexity was estimated by the third author in [Sav03]. The class of contracting groups was formally introduced by Nekrashevych who discovered a deep connection between automaton groups and holomorphic dynamics via the notion of iterated monodromy groups (see [Nek05]). Contracting groups can either be defined through their actions on regular rooted trees or directly using the structure of automata defining group elements.

Each element of a contracting group can be identified with a, so-called, nucleus portrait that is a finite tree whose non-leaf vertices are labelled by permutations of the input alphabet, and the leaves are labelled by the elements of a finite subset of a group called the nucleus. Such a representation can be used as an analogue of the normal form (which is generally not defined for automaton). Using nucleus portraits instead of words to represent elements of a group potentially offers additional security for cryptographic protocols. For example, it was pointed out by Dehornoy [Deh04] that while using cryptographic protocols based on the conjugation in braid groups, the (word) length of the secret conjugator can be inferred from the publicly transmitted data as a consequence of the fact that the normal form in braid groups does not significantly change the length of any reduced word. The size and the structure of a nucleus portrait are much less predictable under conjugation in the case of contracting groups. Moreover, to the best of our knowledge there is no algorithm for a general contracting group that recovers some word in generators that represents a given nucleus portrait. However, we present a polynomial time algorithm in the case of regular branch contracting groups:

Theorem 5.6. *Let G be a contracting self-similar regular branch group generated by set S that contains the nucleus of G . Suppose that $g \in G$ is an element represented by a word in $S^{\pm 1}$ of length n . Then there is a polynomial-time algorithm that, given the nucleus portrait of g , constructs a word in $S^{\pm 1}$ of polynomial in n length, representing g .*

Note, that the words obtained as the outcome of the algorithm in the above theorem are very different from the input words, so even in the case of regular branch contracting groups nucleus portraits significantly obfuscate input words.

We explore the techniques used for cryptanalysis of AAG protocol known as length-based Attack (LBA) on SCSP. This attack was initially introduced by Hughes and Tannenbaum in [HT02] in the context of braid groups and its various forms were studied in several classes of groups, including free groups and groups with generic free basis property [MU08, MU07] and Kahrobaei-Garber-Lam did the analysis for polycyclic groups [GKL15]. The LBA on SCSP attempts to find a secret conjugator heuristically by subsequently find a sequence of “partial conjugators” r_k , $k \geq 1$ that decrease the “length” of a tuple $(a_1^{r_k} b_1^{-1}, a_2^{r_k} b_2^{-1}, \dots, a_n^{r_k} b_n^{-1})$, where the length function can be defined in multiple ways. In our implementation we found that the most reasonable choice for the length function is the sum of the depths of nucleus portraits of the entries of a given tuple. There are several more adjustable parameters of the version of LBA that we implemented that are discussed in detail in Section 6.

Myasnikov and Ushakov suggested in [MU08] that the LBA should work well in groups that have generically free subgroups. By the result of Nekrashevych [Nek10] contracting groups have no free nonabelian subgroups, so they constitute a natural class where LBA may not be effective.

For our statistical analysis we have chosen several contracting groups and included the test results for 8 of them in this paper. These include Grigorchuk group \mathcal{G} , Basilica group $\mathcal{B} \cong IMG(z^2 -$

1), $IMG(z^2 + i)$, Universal Grigorchuk group (acting on 6-ary regular rooted tree), two virtually abelian groups, and 2 groups associated with iterated monodromy groups of quadratic rational functions. We found that the LBA variant against SCSP that we studied is mostly ineffective for groups which are not virtually abelian, but works quite well for 2 groups that contain \mathbb{Z}^2 as a subgroup of index 2.

The paper is organized as follows. In Section 2 we recall several group-based cryptosystems and the algorithmic problems they are based upon. Sections 3 and 4 we introduce the basic notions related to automaton and contracting groups. Our main theoretical result is contained in Section 5, in which we develop an algorithm of recovering a word representing a given nucleus portrait of an element of a contracting regular branch group. Section 6 describes in detail the variant of the length-based attack that we study, and Section 7 contains the results of our statistical analysis of the effectiveness of the proposed length-based attack.

Acknowledgement. The authors would like to express sincere gratitude to Rostislav Grigorchuk for fruitful discussions that helped to improve the paper. The first author conducted this work partially with the support of ONR Grant 62909-24-1-2002. The first author thanks Institut des Hautes Études Scientifiques - IHES for providing stimulating environment while this project was partially done. The second and the third authors greatly acknowledge the support of American Institute of Mathematics (AIM). Part of this work was done in June 2024 during the workshop “Groups of dynamical origin” funded by AIM.

2 Cryptosystems Based on Variants of the Conjugacy Search Problem in Groups

In this section we provide an overview of several well-studied cryptography protocols that are based on variants of conjugacy search problem.

2.1 Commutator key exchange: a.k.a. Anshel-Anshel-Goldfeld (AAG) protocol

As usual, we use two entities, called Alice and Bob, for presenting the two parties which plan to communicate over an insecure channel.

Let G be a group with generators g_1, \dots, g_n . First, Alice chooses her public set $\bar{a} = (a_1, \dots, a_{N_1})$, where $a_i \in G$, and Bob chooses his public set $\bar{b} = (b_1, \dots, b_{N_2})$, where $b_i \in G$. They both publish their sets. Alice then chooses her private key $A = a_{s_1}^{\varepsilon_1} \dots a_{s_L}^{\varepsilon_L}$, where $a_{s_i} \in \bar{a}$ and $\varepsilon_i \in \{\pm 1\}$. Bob also chooses his private key $B = b_{t_1}^{\delta_1} \dots b_{t_M}^{\delta_M}$, where $b_{t_i} \in \bar{b}$ and $\delta_i \in \{\pm 1\}$. Alice computes $b'_i = A^{-1}b_iA$ for all $b_i \in \bar{b}$ and sends it to Bob. Bob also computes $a'_i = B^{-1}a_iB$ for all $a_i \in \bar{a}$ and sends it to Alice. Now, the shared secret key is $K = A^{-1}B^{-1}AB$. Alice can compute this key by:

$$\begin{aligned} K_A &= A^{-1}(a_{s_1}^{\varepsilon_1} \dots a_{s_L}^{\varepsilon_L}) = A^{-1}(B^{-1}a_{s_1}B)^{\varepsilon_1} \dots (B^{-1}a_{s_L}B)^{\varepsilon_L} = \\ &= A^{-1}B^{-1}(a_{s_1}^{\varepsilon_1} \dots a_{s_L}^{\varepsilon_L})B = A^{-1}B^{-1}AB = K. \end{aligned}$$

Similarly, Bob can compute $K_B = B^{-1}(b_{t_1}^{\delta_1} \dots b_{t_M}^{\delta_M}) = B^{-1}A^{-1}BA$, and then he knows the shared secret key by $K = K_B^{-1}$.

We note that solving the simultaneous conjugacy problem is generally not enough to break AAG protocol as the secret conjugators A and B must be found in the respective public subgroups $\langle a_1, \dots, a_{N_1} \rangle$ and $\langle b_1, \dots, b_{N_2} \rangle$. Thus, attacking the protocol requires solving the membership search

problem in addition to the SCSP. The security of the AAG protocol is based on the assumption that the subgroup-restricted simultaneous conjugacy search problem is hard. For more details, see [AAG99].

2.2 Non-commutative Diffie-Hellman: a.k.a. Ko-Lee protocol

Originally specified by Ko, Lee, et al. [KLC⁺00] using braid groups, their non-commutative analogue of Diffie-Hellman key exchange can be generalized to work over other platform groups. Let G be a finitely presented group, with $A, B \leq G$ such that all elements of A and B commute.

An element $g \in G$ is chosen, and g, G, A, B are made public. A shared secret can then be constructed as follows:

- Alice chooses a random element $a \in A$ and sends g^a to Bob.
- Bob chooses a random element $b \in B$ and sends g^b to Alice.
- The shared key is then g^{ab} , as Alice computes $(g^b)^a$, which is equal to Bob's computation of $(g^a)^b$ as a and b commute.

The security of Ko-Lee rests upon solving the conjugacy search problem within the subgroups A, B .

2.3 Non-commutative ElGamal key-exchange: a.k.a. Kahrobaei-Khan Protocol

In the 2006 paper by the first author and Khan [KK06], the authors proposed two adaptations of the ElGamal asymmetric key encryption algorithm for use in non-commutative groups. Let S, T be finitely generated subgroups such that all elements of S and T commute. In any exchange, the triple $\langle G, S, T \rangle$ is made public.

- Bob chooses $s \in S$ as his private key, a random element $b \in G$, and publishes as his public key the tuple $\langle b, c \rangle$, with $c = b^s$.
- To create a shared secret $x \in G$, Alice chooses x and a $t \in T$. Using Bob's public key, she publishes $\langle h, E \rangle$, with $h = b^t$ and $E = x^{c^t}$.
- To recover x , Bob first computes h^s , which, as elements of S and T commute, yields

$$h^s = (b^t)^s = (b^s)^t = c^t.$$

Bob can then calculate $x = E^{(c^t)^{-1}}$.

The security of this scheme relies upon the conjugacy search problem in G .

2.4 Non-commutative digital signature: a.k.a. Kahrobaei-Koupparis DSS

The following digital signature scheme was proposed in a paper by Kahrobaei and Koupparis [KK12]. The platform group G must be infinite. The scheme uses two functions: $f: G \rightarrow \{0, 1\}^*$, which encodes elements of the group as binary strings; and $H: \{0, 1\}^* \rightarrow G$, a collision-resistant hash function. Using these functions (which are made public along with G), a message can be signed and verified as follows:

- *Key Generation:* The signer first chooses an element $g \in G$, whose centralizer, the set of elements that commute with g , contains 1_G and powers of g exclusively. The private key consists of $s \in G$ and $n \in \mathbb{N}$, where n is chosen to be highly composite. The public key $x = g^{ns}$ is then published.
- *Signing Algorithm:* To sign a message m , the signer chooses a random element $t \in G$ and a random factorization $n_i n_j$ of n , and computes the following (with \parallel denoting concatenation):

$$\begin{aligned} y &= g^{n_i t} \\ h &= H(m \parallel f(y)) \\ \alpha &= t^{-1} s h y \end{aligned}$$

The signature $\sigma = \langle y, \alpha, n_j \rangle$ and the message m are then send to the message recipient.

- *Verification:* To verify, the recipient computes $h' = H(m \parallel f(y))$, and accepts the message as authentic if and only if the following equality holds:

$$y^{n_j \alpha} = x^{h' y}.$$

The security of the signature scheme is based on the collision resistance of the hash function, the conjugacy search problem in G , and the Diffie-Hellman assumption. Moreover, Alice must maintain a public list of previously used factors of n , and regenerate s and n after a few uses.

3 Automaton Groups

This section provides an overview of automaton groups. We discuss the motivation behind their various geometric descriptions and establish the notation required to analyze them.

3.1 Trees

Automaton groups act by automorphisms on regular rooted trees. We begin with setting up the terminology.

Definition 3.1. A connected graph with no cycles is called a *tree*. A tree T is called *rooted* if one of its vertices, called the *root* is selected.

The trees are endowed with a combinatorial metric in which the distance between two vertices is equal to the number of edges in the shortest path connecting them.

Definition 3.2. The *n-th level* of a rooted tree T is the set of vertices whose distance from the root is n .

Given that trees have no cycles, each vertex v at level n is connected to the root by a unique path. The vertex v' in this path that lies in level $n - 1$ is called the *parent* of v . The vertex v in this case is called a *child* of v' . Thus every vertex except the root has exactly one parent and may have several children.

Definition 3.3. A rooted tree T is called *regular* (or *d-regular*, or *d-ary*) if there is $d \geq 1$ such that each vertex of T has exactly d children. In case when $d = 2$ such a tree is called *binary*.

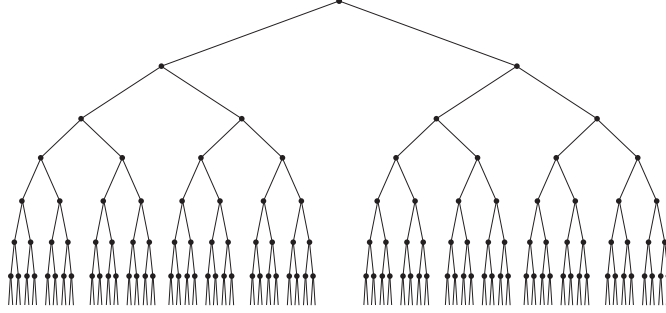

Figure 1: Binary tree

Throughout our discussion, trees grow from top to bottom. Root is the highest vertex and the children of each vertex v are located right under v . We will use T_d as the standard notation to denote the d -ary tree. Figure 1 depicts a binary tree.

Definition 3.4. The group of all graph automorphisms of the regular rooted tree T_d with the operation of composition is called the *full group of automorphisms of T_d* and is denoted $\text{Aut } T_d$.

Let X be a finite set of cardinality d and let X^* denote the set of all finite words over X (that can be thought as the free monoid generated by X). This set can be naturally endowed with a structure of a rooted d -ary tree by declaring that v is adjacent to vx for any $v \in X^*$ and $x \in X$. So the vertices of T_d are labelled by finite words over X . The empty word corresponds to the root of the tree T_d and X^n corresponds to the n -th level of the tree. Given this interpretation, we will often write $\text{Aut } X^*$ for $\text{Aut } T_d$. Thus, we view X^* as a tree and consequently its automorphisms as those of a tree instead of a free monoid on X .

Definition 3.5. For an automorphism g of the tree X^* and $x \in X$, we have that for any $v \in X^*$, $g(xv) = g(x)v'$ for some $v' \in X^*$. Then the map $g|_x: X^* \rightarrow X^*$ given by $g|_x(v) = v'$ defines an automorphism of X^* called *section of g at vertex x* . Furthermore, for any $w = x_1x_2 \dots x_n \in X^*$ we define the section $g|_w$ of g at w as

$$g|_w = g|_{x_1}|_{x_2} \dots |_{x_n}.$$

3.2 Automaton and self-similar groups

Automorphisms of the tree X^* can be described using the language of Mealy automata.

Definition 3.6. A *Mealy automaton* (or simply *automaton*) is a tuple (Q, X, π, λ) , where Q is a set (a set of *states*), X is a finite alphabet, $\pi: Q \times X \rightarrow Q$ is the *transition function* and $\lambda: Q \times X \rightarrow X$ is the *output function*. If the set of states Q is finite the automaton is called *finite*. If for every state $q \in Q$ the output function $\lambda(q, x)$ induces a permutation of X , the automaton \mathcal{A} is called *invertible*. Selecting a state $q \in Q$ produces an *initial automaton* \mathcal{A}_q .

Automata are often represented by the *Moore diagrams*. The Moore diagram of an automaton $\mathcal{A} = (Q, X, \pi, \lambda)$ is a directed graph in which the vertices are the states from Q and the edges have form

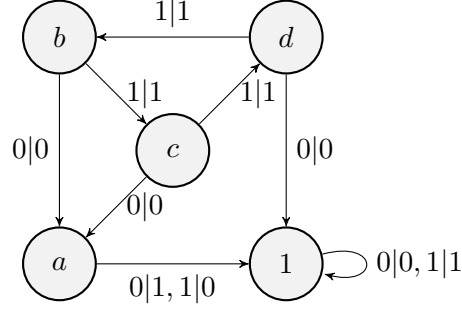
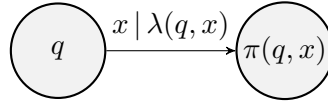

Figure 2: Five-state Automaton $\mathcal{A}_{\mathcal{G}}$ generating the Grigorchuk group \mathcal{G}



for $q \in Q$ and $x \in X$. If the automaton is invertible, then it is common to label vertices of the Moore diagram by the permutation $\lambda(q, \cdot)$ and leave just first components from the labels of the edges. Figure 2 shows Moore diagram for automaton generating the Grigorchuk group \mathcal{G} .

The action of an initial automaton \mathcal{A}_q on X^* is informally defined as follows. Given a word $v = x_1x_2x_3 \dots x_n \in X^*$, the automaton \mathcal{A}_q scans its first letter x_1 and outputs $\lambda(q, x_1)$. The rest of the word is handled in a similar fashion by the initial automaton $\mathcal{A}_{\pi(q, x_1)}$. Formally speaking, the functions π and λ can be extended to $\pi: Q \times X^* \rightarrow Q$ and $\lambda: Q \times X^* \rightarrow X^*$ via

$$\begin{aligned} \pi(q, x_1x_2 \dots x_n) &= \pi(\pi(q, x_1), x_2x_3 \dots x_n), \\ \lambda(q, x_1x_2 \dots x_n) &= \lambda(q, x_1)\lambda(\pi(q, x_1), x_2x_3 \dots x_n). \end{aligned}$$

The invertible initial automata define automorphisms of X^* . Moreover, any automorphism g of X^* can be encoded by the action of an invertible initial automaton with the following construction. Define an initial automaton \mathcal{A}_g whose action on X^* coincides with that of g as follows. The set of states of \mathcal{A}_g is the set $\{g|_v: v \in X^*\}$ of different sections of g at the vertices of the tree. The transition and output functions are defined by

$$\begin{aligned} \pi(g|_v, x) &= g|_{vx}, \\ \lambda(g|_v, x) &= g|_v(x), \end{aligned} \tag{1}$$

and the initial state of \mathcal{A}_g is g . We note that \mathcal{A}_g does not need to be finite.

Definition 3.7. The group generated by all states of an invertible automaton \mathcal{A} is called an *automaton group* and denoted by $\mathbb{G}(\mathcal{A})$.

Figure 2 shows the five-state automaton $\mathcal{A}_{\mathcal{G}}$ that generates the Grigorchuk group \mathcal{G} acting on X^* for $X = \{0, 1\}$.

Often the language of self-similar groups is used to describe automorphisms of a tree X^* as well.

Definition 3.8. A subset S of $\text{Aut } X^*$ is *self-similar* if all sections (as defined in Definition 3.5) of each element in S are in S again. A group $G < \text{Aut } X^*$ is called *self-similar* if it is self-similar as a set.

Clearly, a self-similar set S has a structure of an automaton with transitions defined by:

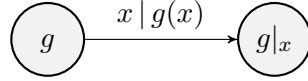

for each $g \in S$ and $x \in X$.

An automaton group can be naturally defined as a group generated by a self-similar set. On the other hand, the whole self-similar group G defines an automaton $\mathcal{A}(G)$ whose states are elements of the group.

The following trivial observation relates self-similar and automaton groups.

Proposition 3.9. *A group G is self-similar if and only if it is generated by (possibly infinite) automaton.*

The group $\text{Aut}(X^*)$ is naturally isomorphic to $\text{Aut}(X^*) \wr \text{Sym}(d)$ via the map

$$G \ni g \mapsto (g|_0, g|_1, \dots, g|_{d-1})\sigma_g \in G \wr \text{Sym}(X), \quad (2)$$

where $\sigma_g \in \text{Sym}(d)$ is the permutation of X induced by the action of g on the first level of X^* . We will often identify g with its image under this embedding and write

$$g = (g|_0, g|_1, \dots, g|_{d-1})\sigma_g.$$

The right-hand side of the last expression is called the *wreath recursion* of g . If σ_g is the trivial permutation, it is customary to omit it in the wreath recursion.

The language of wreath recursion allows us to do effective calculations with elements of $\text{Aut}(X^*)$. To state this precisely, we adopt the following convention throughout the paper: If g and h are elements of some group acting on a set Y and $y \in Y$, then $gh(y) = h(g(y))$. In other words, we agree to consider only right actions of groups.

Now, if $g = (g_0, g_1, \dots, g_{d-1})\sigma_g$ and $h = (h_1, h_2, \dots, h_d)\sigma_h$ are two elements of $\text{Aut } X^*$, then by the definition of the wreath product we get:

$$gh = (g_0 h_{\sigma_g(0)}, g_1 h_{\sigma_g(1)}, \dots, g_{d-1} h_{\sigma_g(d-1)}) \sigma_g \sigma_h \quad (3)$$

and

$$g^{-1} = \left(g_{\sigma_g^{-1}(0)}^{-1}, g_{\sigma_g^{-1}(1)}^{-1}, \dots, g_{\sigma_g^{-1}(d-1)}^{-1} \right) \sigma_g^{-1}. \quad (4)$$

The last two equalities form the basis for effective calculations in groups generated by automata.

4 Contracting Groups

In this section we provide an overview of the class of contracting groups. In particular we recall the notion of a *nucleus portrait* of an element of a contracting group that will play a role of the normal form of an element and that we propose to use as the way to transmit elements of these groups through communication channels. We refer the reader to [Nek05] for details.

4.1 Basic definitions and properties

Definition 4.1. A self-similar group $G < \text{Aut } X^*$ is called *contracting* if there exists a finite set $\mathcal{N} \subset G$ such that for each $g \in G$ there is a level $l \geq 0$ so that for all $k \geq l$ we have $g|_v \in \mathcal{N}$ for all $v \in X^k$. The minimal set \mathcal{N} is called the *nucleus* of G . Any finite subset of G containing the nucleus is called *quasinucleus*.

The following proposition can be considered as a second definition of contracting groups (see [Nek05, Lemma 2.11.12]) and justifies the term “contracting”. For an element g of a group G generated by a set S we will denote by $|g|_S$ the length of g with respect to S , i.e., the length of the shortest word in $S^{\pm 1}$ representing g .

Proposition 4.2. *A self-similar group G generated by a self-similar generating set S is contracting if and only if there exist $C > 0$ and level $N \geq 1$ such that for any element g of G*

$$|g|_S < \frac{1}{2}|g|_S + C$$

for each vertex $v \in X^N$.

For the first time contracting type arguments were applied by Grigorchuk in his construction of the first Burnside group of intermediate growth (a.k.a. Grigorchuk group) \mathcal{G} [Gri80, Gri84]. It is contracting with the nucleus consisting of five elements $\mathcal{N} = \{1, a, b, c, d\}$. We note that in this case the nucleus coincides with the set of states of the automaton generating \mathcal{G} , but in general it need not be the case. The term “contracting” was coined by Nekrashevych [Nek05], who developed the theory of Iterated Monodromy Groups, in which contracting groups play a key role.

Every element g of G can be uniquely described by its nucleus portrait that we define below. By definition, there is some minimal level $l \geq 0$ so that for all $k \geq l$ we have $g|_v \in \mathcal{N}$ for all $v \in X^k$. Therefore, we can identify g with a finite tree of depth l whose vertices are labelled by permutations of X and leaves are labelled by the elements of the nucleus.

Definition 4.3. Let g be an element of a contracting group G acting on a d -ary rooted tree X^* with the nucleus \mathcal{N} . The *nucleus portrait* $\pi(g)$ of $g \in G$ is a labelled tree obtained recurrently as follows. If $g \in \mathcal{N}$ then the nucleus portrait of g is a single vertex labelled by g . Otherwise the nucleus portrait of g starts with a single vertex labelled by the permutation induced by g on the first level of X^* that is connected to d children on the first level that are roots of the portraits of $g|_x$ for $x \in X$.

Note that the contracting property of the groups guarantees that the nucleus portrait of every element is finite. If two words in the generators of a contracting group give rise to two identical nucleus portraits then they represent the same element of the group.

When we will describe multiplication of nucleus portraits in Subsection 4.2 we will also need a bit more general notion of a *portrait* of an element of a self-similar group, which is defined similarly to the nucleus portrait, but without the requirement that the leaves must be labelled by the elements of the nucleus. In other words, a portrait of g is any finite subtree of X^* containing the root whose internal vertices are labelled by the permutations induced by g at these vertices, and whose leaves are labelled by the sections of g at the corresponding vertices. Clearly, unlike in the case of nucleus portraits, there are many portraits representing the same element of a group.

One of the main computational advantages of contracting group is that the word problem is decidable in polynomial time [Nek05] (with the main idea of the algorithm consisting in comparing nucleus portraits of the input words). Additionally, one can bound the degree of a polynomial solving the word problem by $(|\mathcal{N}|^2 - 1) \log_2 d + \varepsilon$ as shown in [Sav03].

Definition 4.4. For an element g of a contracting group G the *depth* of g , denoted by $\partial(g)$ is the depth of $\pi(g)$ (i.e., the number of levels of $\pi(g)$). We will also call the number of leaves of $\pi(g)$ the *portrait boundary size* of g and denote by $s(g)$.

The notion of the depth of an element was introduced by Sidki in [Sid87]. The nucleus portraits were introduced for the first time by Grigorchuk in [Gri05] under the name of *core portraits*. Additionally, Grigorchuk defined the portrait growth function and provided some bounds for this function for Grigorchuk group. Šunić and Uria-Albizuri in a recent paper [ŠUA23] derived asymptotic behaviour of this function for Grigorchuk group (that turns out to be double-exponential) and obtained recursive formulas for the portrait growth of any finitely generated contracting regular branch group.

If G is a contracting group generated by a finite set S , there is a direct relation between the length $|g|_S$ of $g \in G$ with respect to S and both $\partial(g)$ and $s(g)$.

Proposition 4.5. *Suppose G is a contracting group generated by a finite self-similar set S containing the nucleus of G . Then there is $R > 0$ such that for each $g \in G$*

$$\partial(g) \leq \lceil R \log_2 |g|_S + R \rceil.$$

Proof. By applying Proposition 4.2 $\lceil \log_2 |g|_S \rceil$ times we obtain that for any vertex v of level $\lceil N \log_2 |g|_S \rceil$:

$$|g|_v|_S < \frac{1}{2^{\lceil \log_2 |g|_S \rceil}} |g|_S + \sum_{i=0}^{\lceil \log_2 |g|_S \rceil - 1} \frac{C}{2^i} \leq 1 + \sum_{i=0}^{\infty} \frac{C}{2^i} = 1 + 2C.$$

Let

$$M = \max\{\partial(h) : h \in G, |h|_S \leq 1 + 2C\}$$

be the level at which all elements in G of length up to $1 + 2C$ contract to the nucleus. Then g will contract to the nucleus at level $\lceil N \log_2 |g|_S \rceil + M = \lceil N \log_2 |g|_S + M \rceil$. Thus, we can choose $R = \max\{N, M\}$. \square

Corollary 4.6. *Suppose G is a contracting group generated by a finite self-similar set S containing the nucleus of G . Then the portrait boundary size of an element $g \in G$ is at most polynomial in $|g|_S$.*

Proof. The portrait boundary size $s(g)$ of $g \in G$ is bounded from above by the number of leaves of the d -ary tree of depth $\partial(g)$, so we get by Proposition 4.5 that there is $R > 0$ such that

$$\begin{aligned} s(g) &\leq d^{\partial(g)} \leq d^{\lceil R \log_2 |g|_S + R \rceil} \leq d^{R \log_2 |g|_S + R + 1} \\ &= d^{R+1} d^{\frac{\log_d |g|_S^R}{\log_d 2}} = d^{R+1} d^{\log_d |g|_S^{R \log_2 d}} = d^{R+1} |g|_S^{R \log_2 d}. \end{aligned}$$

\square

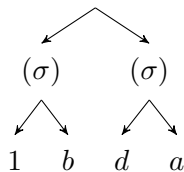

Figure 3: Nucleus portrait for $acab \in \mathcal{G}$

The last corollary shows that the amount of information required to transmit the portrait is polynomial in the length of a word representing that element. However, in most cases the actual contracting depth of an element is much smaller than the theoretical bound from Proposition 4.5 and the number of the nodes in the portraits is very similar (and in many cases, like in Grigorchuk group is actually much smaller) than the length of the word defining the element.

We have also computed, in the case of Grigorchuk group, the average portrait depths and the ratios of portrait boundary sizes to the number of vertices at the contracting depth levels. More precisely, given a contracting group G acting on a d -ary tree, for $g \in G$, we define the ratio $\mathcal{R}_g = \frac{s(g)}{d^{\partial(g)}}$. Table 1 displays variation of average \mathcal{R}_g and average portrait depth $\partial(g)$ against the reduced word length for randomly generated elements of Grigorchuk group. Each average value is calculated using 100 randomly generated elements for the respective word length.

Group	Grigorchuk Group						
Reduced word length	100	200	500	1000	2000	5000	10000
Average ratio \mathcal{R}_g	0.47	0.41	0.38	0.35	0.33	0.30	0.32
Average portrait depth	5.49	6.18	6.97	7.64	8.11	8.95	9.42

Table 1: Variation in average \mathcal{R}_g and average $\partial(g)$ against reduced word length for Grigorchuk group. Each average is calculated using 100 randomly generated elements for the respective word length.

4.2 Computations with nucleus portraits

In this section, we show that the nucleus portraits can be used effectively for computations in contracting groups. Following a description of performing basic computations using nucleus portraits, we provide a specific simple example of deploying contracting groups as platforms for AAG cryptosystem. Each step of the key-generation process is demonstrated using examples from Grigorchuk group. The described routines are implemented in the GitHub repository [KMS24].

Let G be a contracting group with nucleus \mathcal{N} and let $g, h \in G$ be arbitrary given by their portraits $\pi(g)$ and $\pi(h)$. Below we show how to construct portraits of gh and g^{-1} .

1. Multiplication of two nucleus portraits $p = \pi(g)$ and $q = \pi(h)$:
 - (a) Let $L = \max\{\partial(g), \partial(h)\}$ be the maximum of the depths of the portraits of g and h .

- (b) Extend the portraits of p and q to the new portrait depth L by adding missing branches and labelling new internal vertices by permutations of X induced by the corresponding sections of g and h at these vertices, and also labelling new leaves by the elements of the nucleus corresponding to the sections of g and h at these vertices (this information is immediately derived from the portraits since we assumed the nucleus is a self-similar set). We denote these extended portraits by p' and q' respectively.
- (c) Using the labelling of p' and q' , determine the permutations σ and τ induced by g and h at the level L . These permutations, together with the labels of the leaves of p' and q' , yield the representation of g and h as elements $(g_1, g_2, \dots, g_{d^L})\sigma$ and $(h_1, h_2, \dots, h_{d^L})\tau$ in $G \wr \text{Sym}(d^L)$.
- (d) Compute the wreath recursion of gh on level L as

$$gh = (g_1 h_{\sigma(1)}, g_2 h_{\sigma(2)}, \dots, g_{d^L} h_{\sigma(d^L)})\sigma\tau.$$

- (e) From the permutation $\sigma\tau$ of $\{1, 2, \dots, d^L\}$ inductively obtain the action of gh at the vertices of all levels up to $L - 1$, thus compute portrait of gh on level L with leaves labelled by $g_i h_{\sigma(i)}$, $1 \leq i \leq d^L$.
 - (f) (Portrait extension) For each leaf label $g_i h_{\sigma(i)}$ check if it belongs to \mathcal{N} . If it is equal to $n \in \mathcal{N}$ then replace this label by n . Otherwise attach the portrait of $g_i h_{\sigma(i)}$ to the portrait of gh by connecting its root to the this leaf.
 - (g) (Portrait pruning) For each tuple of d consecutive leaves (n_1, n_2, \dots, n_d) whose labels are in \mathcal{N} that are children of the same vertex v check if there is an element $n \in \mathcal{N}$ whose wreath recursion at the first level coincides with $(n_1, n_2, \dots, n_d)\sigma_v$, where σ_v is the permutation of gh at vertex v . If this is the case, delete leaves (n_1, n_2, \dots, n_d) from the portrait of gh and label the new leaf at v by n .
 - (h) Repeat the last step while possible.
 - (i) The obtained portrait is the nucleus portrait of gh .
2. Inverse of nucleus portrait p (see Figure 4 for illustration):
- (a) Act on the portrait of p by permutations that are the labels of the internal vertices. Namely, at each internal vertex v of p labelled by a permutation σ permute the portraits attached to this vertex according to this permutation.
 - (b) Replace all the labels (both internal labels and the labels of the leafs) by their inverses. Note that the nucleus is always closed under taking inverses since it is the self-similar closure of all the cycles in the automaton of the whole group.
 - (c) The obtained portrait is the nucleus portrait of g^{-1} .

Other elementary computations such as conjugation for nucleus portraits can be performed following a sequence of the aforementioned procedures for multiplication and taking inverse.

4.3 An explicit example of AAG key generation using nucleus portraits

The key generation process for the AAG protocol described in Subsection 2.1 requires computations using nucleus portraits. We illustrate here the techniques from the previous subsection using the

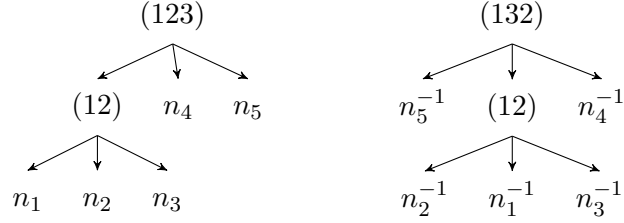

Figure 4: An example of nucleus portraits of inverse group elements

example of Grigorchuk group \mathcal{G} to demonstrate the steps of AAG protocol. In this example, the public keys of Alice and Bob comprise of 3 elements of \mathcal{G} represented by reduced words of length 10 each.

Following AAG key-generation mechanism using contracting automaton group G :

1. Given set of states $Q = \{q_1, \dots, q_N\}$ of automaton \mathcal{A} generating the contracting group G , Alice chooses a set $\bar{a} = (a_1, \dots, a_{N_1})$ where a_i are reduced words over Q . Then she develops nucleus portraits for each element of the set and publishes them as her public key.

For example, let Alice choose the following tuple from Grigorchuk group:

$$\bar{a} = (a_1 = (daba)^2ba, a_2 = b(ad)^2abada, a_3 = (ad)^3abac).$$

The nucleus portraits for this set as shown in Table 2 will be published as her public key.

2. Bob chooses a set, $\bar{b} = (b_1, \dots, b_{N_2})$ where b_i are reduced words over states Q of the automaton \mathcal{A} that generates G . Then he develops the nucleus portraits for each element of the set and publishes them as his public key.

For example, let Bob choose the the following tuple from Grigorchuk group:

$$\bar{b} = (b_1 = d(ab)^2acada, b_2 = cab(ad)^3a, b_3 = bac(ab)^3a).$$

Then he develops the nucleus portrait for each word and publishes them as his public key. This is shown in Table 3.

3. Alice then chooses $A = a_{s_1}^{\varepsilon_1} \dots a_{s_L}^{\varepsilon_L}$ where $a_{s_i} \in \bar{a}$ and $\varepsilon_i \in \{\pm 1\}$. The nucleus portrait of A is her private key.

For our example, Alice chooses her private key to be nucleus portrait of $A = a_1a_2a_3$ as shown in Figure 5.

4. Bob chooses $B = b_{t_1}^{\delta_1} \dots b_{t_M}^{\delta_M}$ where $b_{t_i} \in \bar{b}$ and $\delta_i \in \{\pm 1\}$. Then he develops the nucleus portrait of B that serves as his private key.

In our example, Bob choose his private key to be nucleus portrait of $B = b_1b_2b_3$ as shown in Figure 6.

5. Using the nucleus portraits, Alice computes $b'_i = A^{-1}b_iA$ for all $b_i \in \bar{b}$ and sends them to Bob (as nucleus portraits). Similarly, Bob computes $a'_i = B^{-1}a_iB$ for all $a_i \in \bar{a}$ as nucleus

portraits and sends them to Alice. Now the shared secret key is the nucleus portrait of $K = A^{-1}B^{-1}AB$.

To conclude our example, the shared secret key is the nucleus portrait of $K = A^{-1}B^{-1}AB$ as shown in Figure 7.

We emphasize that the public keys of Alice and Bob comprise only of nucleus portraits and all computations and communication between the parties takes place in this form. The reduced words used to develop those portraits are never in public domain at any stage of the key generation process.

Group element	$a_1 = (daba)^2ba$	$a_2 = b(ad)^2abada$	$a_3 = (ad)^3abac$
Nucleus portrait			

Table 2: Nucleus portraits for a_1, a_2 and a_3 that constitute the public key of Alice.

Group element	$b_1 = d(ab)^2acada$	$b_2 = cab(ad)^3a$	$b_3 = bac(ab)^3a$
Nucleus portrait			

Table 3: Nucleus portraits for b_1, b_2 and b_3 that constitute the public key of Bob.

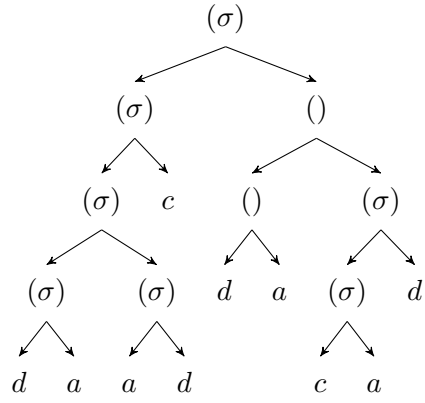

Figure 5: Nucleus portrait of Alice's private key $A = a_1a_2a_3$.

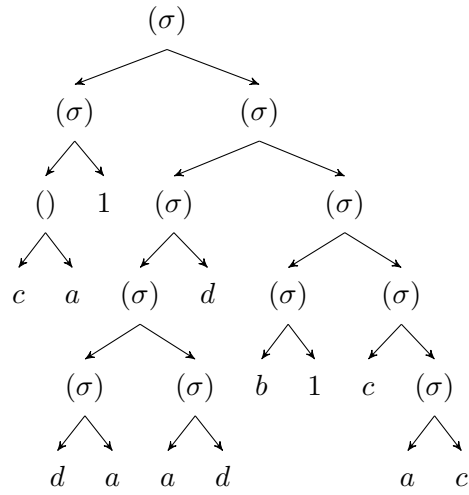

Figure 6: Nucleus portrait of Bob's private key $B = b_1b_2b_3$.

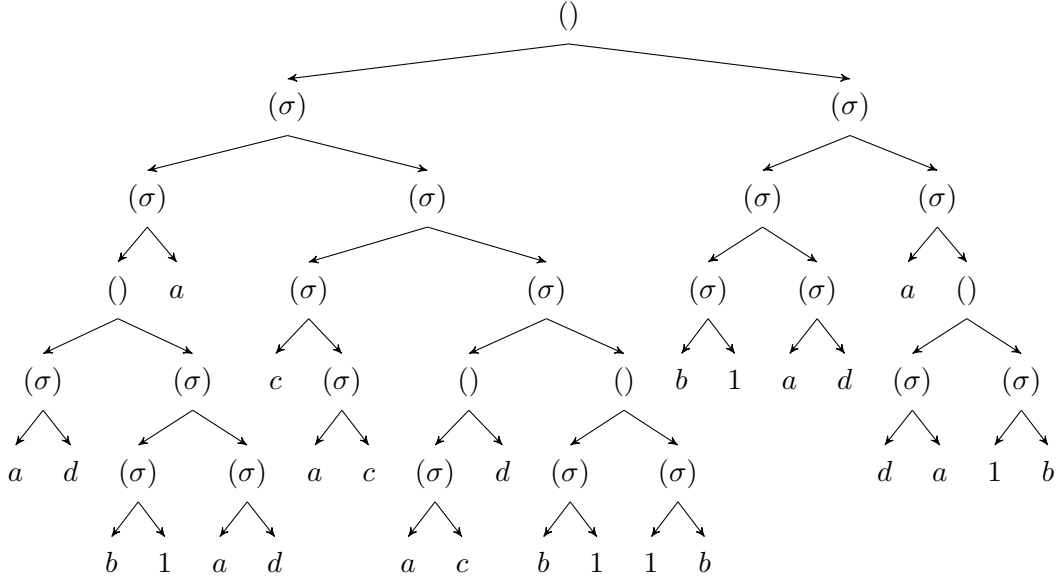

Figure 7: Nucleus portrait of the shared key $K = A^{-1}B^{-1}AB$.

5 Recovering Words from Nucleus Portraits

In this section we provide an algorithm that recovers a word representing an element g of a regular branch group G from its portrait of a fixed depth or, if a group is contracting, from its nucleus portrait. Moreover, we show that if G is contracting, then, given the nucleus portrait of an element g of length n in G , this algorithm constructs a word of polynomial in n length. The algorithm is a generalization of a similar algorithm for Grigorchuk group described in [Gri05, LMU10]. The authors are grateful to Rostislav Grigorchuk for pointing out the connection to the original algorithm that served as a basis for the result below.

We begin from recalling the definition of regular branch groups. Consider a self-similar group G and its normal subgroup $\text{St}_G(1)$ consisting of all elements in G that stabilize the first level of X^* . There is a natural embedding

$$\Psi: \text{St}_G(1) \hookrightarrow G \times G \times \cdots \times G$$

given by

$$g \xrightarrow{\Psi} (g|_0, g|_1, \dots, g|_{d-1}).$$

Definition 5.1. Let K, K_0, \dots, K_{d-1} be subgroups of a self-similar group G acting on X^* . We say that K *geometrically contains* $K_0 \times \cdots \times K_{d-1}$ and write

$$K_0 \times \cdots \times K_{d-1} \preceq K$$

if $K_0 \times \cdots \times K_{d-1} \leq \Psi(\text{St}_G(1) \cap K)$.

Definition 5.2. A group G of tree automorphisms of X^* that acts transitively on the levels of the tree X^* is called a *regular weakly branch group* over its nontrivial subgroup K if

$$K \times \cdots \times K \preceq K.$$

If, in addition, $[G : K] < \infty$ and $[\Psi(\text{St}_G(1) \cap K) : K \times \cdots \times K] < \infty$ (i.e., K geometrically contains $K \times \cdots \times K$ as a subgroup of finite index), then G is called a *regular branch group* over K . The group K is then called a *branching subgroup* in G .

Lemma 5.3. *Let G be a regular branch group generated by a finite set S acting on a d -ary rooted tree X^* with a branching subgroup K . Then, given a tuple $(g_1, g_2, \dots, g_d) \in K^d$, where g_i 's are given as words in $S^{\pm 1}$, there is a word w in $S^{\pm 1}$ of length at most $C \sum_{i=1}^d |g_i|_S$ that represents $(g_1, g_2, \dots, g_d) \in K < G$ for some $C > 0$ not depending on g_i 's.*

Proof. We first construct the Schreier graph $\Gamma = \Gamma(G, K, S)$ of K in G with respect to S (which is finite since $[G : K] < \infty$) and use it to construct a finite generating set $S_K = \{a_1, a_2, \dots, a_r\}$ of K via the Reidemeister-Schreier process. For each $1 \leq i \leq r$ and $1 \leq j \leq d$ we define

$$a_{i,j} = (1, \dots, 1, a_i, 1, \dots, 1) \in K \times \cdots \times K,$$

where the nontrivial component a_i is located in the j -th coordinate. By construction

$$K \times \cdots \times K = \langle a_{i,j} : 1 \leq i \leq r, 1 \leq j \leq d \rangle.$$

Since $K \times \cdots \times K \preceq K$, for each $a_{i,j}$ there is a word $w_{i,j}$ in $S_K^{\pm 1}$ representing $a_{i,j}$. Let

$$L = \max_{i,j} |w_{i,j}|_{S_K}.$$

Let $M = \max_i |a_i|_S$ be the maximal length of generators a_i . Then for every $h \in H$

$$|h|_S \leq M|h|_{S_K}. \quad (5)$$

On the other hand, since S_K is the generating set constructed by the Reidemeister-Schreier process, every word w in $S^{\pm 1}$ representing an element of K corresponds to the loop in Γ that starts and ends at the coset K . Following this loop and recording labels of edges that are not in the spanning tree of Γ that was used to construct S_K , yields a word in S_K representing the same element of K as w represents of length not larger than the length of w . Therefore, for each $h \in K$

$$|h|_{S_K} \leq |h|_S. \quad (6)$$

Now, given $(g_1, g_2, \dots, g_d) \in K^d$, where g_i 's are given as words in $S^{\pm 1}$, we can rewrite each of g_i 's as a word in $S_K^{\pm 1}$ of length at most $|g_i|_S$, then lift every letter $a_{i,j}$ in each of these words to a word $w_{i,j}$ of length at most L in S_K and obtain a word w' in $S_K^{\pm 1}$ of length at most

$$|w'|_{S_K} = L \sum_{i=1}^d |g_i|_S$$

representing (g_1, g_2, \dots, g_d) . Finally, rewriting w' as a word in $S^{\pm 1}$ will create a word w in $S^{\pm 1}$ of length at most $ML \sum_{i=1}^d |g_i|_S$ by (5). We finish the proof by setting $C = ML$. \square

Lemma 5.4. *Let G be a regular branch group generated by a finite set S acting on a d -ary rooted tree X^* with a branching subgroup K . Suppose $(u_1, \dots, u_d), (v_1, \dots, v_d) \in G^d$ be such that $Ku_i = Kv_i$ for all $1 \leq i \leq d$. If there is $u \in \text{St}_G(1)$ such that $\Psi(u) = (u_1, \dots, u_d)$, then there is $v \in \text{St}_G(1)$ such that $\Psi(v) = (v_1, \dots, v_d)$.*

Proof. By assumption since u_i and v_i lie in the same K -coset, there is $k_i \in K$ such that $u_i = k_i v_i$. Then

$$\Psi(u) = (u_1, \dots, u_d) = (k_1 v_1, \dots, k_d v_d) = (k_1, \dots, k_d)(v_1, \dots, v_d).$$

Since $K \times \dots \times K \preceq K$, there is $k \in K$ such that $\Psi(k) = (k_1, \dots, k_d)$ and thus, for $v = k^{-1}u$ we have

$$\Psi(v) = \Psi(k)^{-1}\Psi(u) = (v_1, \dots, v_d)$$

as required. \square

The key component of the algorithm is the following Lemma

Lemma 5.5. *Suppose G is a regular branch group generated by a finite set S acting on a d -ary rooted tree X^* . Then, given a tuple $(g_1, g_2, \dots, g_d) \in G^d$ and $\sigma \in \text{Sym}(X)$ there is an algorithm deciding in a linear time of $\sum_{i=1}^d |g_i|_S$ if there is $g \in G$ such that $g = (g_1, g_2, \dots, g_d)\sigma$, and finding a word in $S^{\pm 1}$ representing g of length at most $D \cdot \left(\sum_{i=1}^d |g_i|_S\right) + D$ for some $D > 0$ not depending on g_i 's.*

Proof. Suppose K is the branching subgroup in G . We first observe

$$K \times \dots \times K < \Psi(\text{St}_G(1)) < G \times \dots \times G. \quad (7)$$

Since $[G : K] < \infty$ we get $[G \times \dots \times G : K \times \dots \times K] < \infty$ and thus (7) yields $[G \times \dots \times G : \Psi(\text{St}_G(1))] < \infty$. Consider the Schreier graph $\tilde{\Gamma} = \Gamma(G^d, \Psi(\text{St}_G(1)), \tilde{S})$ of $\Psi(\text{St}_G(1))$ in G^d with respect to the generating set \tilde{S} of G^d :

$$\tilde{S} = \{(1, \dots, 1, s, 1, \dots, 1) : s \in S, 1 \leq i \leq d\},$$

where the nontrivial component in the expression above is at position i .

With the help of $\tilde{\Gamma}$ we can determine if for a tuple $(g_1, \dots, g_d) \in G^d$, where g_i 's are given by words over $S^{\pm 1}$, there exists $g \in \text{St}_G(1)$ with $\Psi(g) = (g_1, \dots, g_d)$. This can be done in a linear time in $\sum_{i=1}^d |g_i|_S$ as we have to follow the path in $\tilde{\Gamma}$ of that length. Moreover, for each particular tuple $(g_1, \dots, g_d) \in \Psi(\text{St}_G(1))$ we can find $g \in \Psi^{-1}(G^d)$ as a word in $S^{\pm 1}$ simply by enumerating all elements in $\text{St}_G(1)$ and checking whether their images under Ψ coincide with (g_1, \dots, g_d) .

Let \mathcal{T} denote the right transversal of K in G and let also L be the maximal length of words representing elements of \mathcal{T} . Then $\mathcal{T}^d < G^d$ is a finite list of tuples such that for each (t_1, \dots, t_d) we can precompute if there exists $g \in \text{St}_G(1)$ such that $\Psi(g) = (t_1, \dots, t_d)$ and find the corresponding word in $S^{\pm 1}$ representing such a g . Let N denote the maximal length of all of such words.

Let P be the finite subgroup of $\text{Sym}(X)$ generated by permutations on the first level of the tree X^* of all generators of G . For each $\sigma \in P$ we find an element $h_\sigma \in G$ as a word in $S^{\pm 1}$ that induces permutation σ on the first level of X^* . Let also K be the maximal length of all h_σ , $\sigma \in P$ and of all their sections on the first level.

Now, suppose we have a tuple $(g_1, \dots, g_d) \in G^d$, where g_i 's are given as words in $S^{\pm 1}$, and $\sigma \in \text{Sym}(X)$. This defines an automorphism $g = (g_1, \dots, g_d)\sigma$ of X^* that may or may not be in G . If $\sigma \notin P$, then obviously $g \notin G$. Otherwise, let $h = h_\sigma = (h_1, \dots, h_d)\sigma \in G$ and let w_1 be a precomputed word in $S^{\pm 1}$ of length at most K representing h with the sections of h also given by words of length at most K . By construction, $g \in G$ if and only if

$$gh^{-1} = (g_1 h_{\sigma(1)}^{-1}, \dots, g_d h_{\sigma(d)}^{-1}) \in \text{St}_G(1).$$

Using the Schreier graph Γ of K in g for each $1 \leq i \leq d$ we can find in a linear time in $|g_i h_{\sigma(i)}^{-1}|_S \leq |g_i|_S + K$ the coset representative t_i of $K g_i h_{\sigma(i)}^{-1}$ and define $k_i = g_i h_{\sigma(i)}^{-1} t_i^{-1} \in K$ and note that k_i are words in $S^{\pm 1}$ with

$$|k_i|_S = |g_i h_{\sigma(i)}^{-1} t_i^{-1}|_S \leq |g_i|_S + |h_{\sigma(i)}|_S + |t_i^{-1}|_S \leq |g_i|_S + K + L.$$

Then we can write

$$gh^{-1} = (k_1 t_1, \dots, k_d t_d) = (k_1, \dots, k_d)(t_1, \dots, t_d).$$

By Lemma 5.4 $gh^{-1} \in G$ if and only if $(t_1, \dots, t_d) \in G$, which, as described above, can be precomputed. If $(t_1, \dots, t_d) \notin G$ then $gh^{-1} \notin G$ and $g \notin G$. Otherwise, there exists a (precomputed) word w_2 in $S^{\pm 1}$ of length at most N such that

$$\Psi(w_2) = (t_1, \dots, t_d) \tag{8}$$

By Lemma 5.3 there is a constant $C > 0$ (not dependent on k_i 's) and a word w_3 in $S^{\pm 1}$ of length

$$|w_3|_S \leq C \sum_{i=1}^d |k_i|_S \leq C \sum_{i=1}^d (|g_i|_S + K + L) = C \sum_{i=1}^d |g_i|_S + dC(K + L),$$

such that

$$\Psi(w_3) = (k_1, \dots, k_d). \tag{9}$$

Finally, since

$$g = gh^{-1} \cdot h = (k_1, \dots, k_d)(t_1, \dots, t_d)h$$

we obtain a word $w = w_3 w_2 w_1$ in $S^{\pm 1}$ representing g of length

$$|w|_S \leq |w_3|_S + |w_2|_S + |w_1|_S \leq C \sum_{i=1}^d |g_i|_S + (dC(K + L) + N + K).$$

We finish the proof by setting

$$D = \max\{C, dC(K + L) + N + K\}.$$

□

Theorem 5.6. *Let G be a contracting self-similar regular branch group generated by the set S that contains the nucleus of G . Suppose that $g \in G$ is an element represented by a word in $S^{\pm 1}$ of length n . Then there is a polynomial-time algorithm that, given the nucleus portrait of g , constructs a word in $S^{\pm 1}$ of polynomial in n length, representing g .*

Proof. Since G is contracting, by Proposition 4.5 there is $R > 0$ such that for each element of length n the depth of nucleus portrait of this element is at most $t = \lceil R \log_2 n + R \rceil$. We will build the word representing g from bottom up using Lemma 5.5. At the level t all sections belong to the nucleus, so their length with respect to S is equal to 1. For every vertex of level $t - 1$ by Lemma 5.5 we can construct words of length $Dd + D$ representing section of g at that vertex. Applying Lemma 5.5 on each level, we inductively construct words of length up to

$$(Dd)^i + (Dd)^{i-1}D + (Dd)^{i-2}D + \dots + (Dd)D + D = (Dd)^i \left(1 - \frac{D}{1 - Dd}\right) + \frac{D}{1 - Dd}$$

that represent the sections of g at vertices of level $t - i$, $0 \leq i \leq t$.

Therefore, at level 0, for $i = t$, we get a word w representing g of length

$$\begin{aligned} |w|_s &\leq (Dd)^t \left(1 - \frac{D}{1 - Dd}\right) + \frac{D}{1 - Dd} \leq (Dd)^{R \log_2 n + R + 1} \left(1 - \frac{D}{1 - Dd}\right) + \frac{D}{1 - Dd} \\ &= (Dd)^{\log_{Dd} n^{R \log_2(Dd)}} (Dd)^{R + 1} \left(1 - \frac{D}{1 - Dd}\right) + \frac{D}{1 - Dd} \\ &= n^{R \log_2(Dd)} (Dd)^{R + 1} \left(1 - \frac{D}{1 - Dd}\right) + \frac{D}{1 - Dd}. \end{aligned}$$

The polynomial-time complexity estimate also follows from iterative applications of Lemma 5.5. \square

6 Length-Based Attack

The length-based attack (LBA) is a probabilistic attack that can be applied against many computational problems and cryptographic protocols, in particular those that are based on the variants of the SCSP, such as AAG and Ko-Lee protocols described in Section 2.

Different variants of LBA against SCSP and other related problems were studied in the cases of braid groups [HT02, GKT⁺05, GKT⁺06, MU07], Thompson's group [RST07], free groups and groups with generic free basis property [MU08], and polycyclic groups [GKL15].

Let G be a finitely generated group. By a *length function* on G^n we will call a function $l: G^n \rightarrow \mathbb{N} \cup \{0\}$ satisfying $l((g_1, \dots, g_n)) = 0$ if and only if $g_i = 1_G$ for all i . The idea of LBA against the SCSP in G (respectively, AAG problem over G) is the following. Given two conjugated tuples of group elements $\bar{a} = (a_1, \dots, a_n)$ and $\bar{b} = (b_1, \dots, b_n)$ LBA tries to find a conjugator r in G (respectively, in $\langle a_1, \dots, a_n \rangle$) that conjugates \bar{a} to \bar{b} by iteratively choosing elements r_1, r_2, \dots, r_t from a precomputed finite set \mathcal{R} such that for some predefined length function l :

$$l(\bar{a}^{r_1 r_2 \dots r_k r_{k+1}} \bar{a}^{-1}) < l(\bar{a}^{r_1 r_2 \dots r_k} \bar{b}^{-1})$$

for all $0 \leq k \leq t$ and such that

$$l(\bar{a}^{r_1 r_2 \dots r_t} \bar{b}^{-1}) = 0,$$

in which case $r = r_1 r_2 \dots r_t$ is the required conjugator.

Since the set \mathcal{R} is finite and $l(\bar{a}^{r_1 r_2 \dots r_k} \bar{b}^{-1})$ decreases discretely by at least 1 every time, the whole attack represents a finite search. Note that under the assumption that the search is completed in its entirety, there is no difference in the success rates of the attacks but there may be some differences in time required to conduct these attacks depending on implementation details. In Algorithm 1 we recurrently go through all possible branches as soon as the length is decreased. Some of the cited implementations also impose additional memory restrictions that will affect the success rate, but also limit the time/space required for the attack. In our implementation we do not have any such limitations.

We will call elements of \mathcal{R} *conjugator factors*. The choice of the set \mathcal{R} varies in different versions of LBA to improve the speed or effectiveness of the attack. In some versions of the attack only finite amount of memory is allocated, so that the search is not done over the entire search space. The algorithm for LBA that we implement and analyze in this paper, Algorithm 1, does not make any assumptions on the finite memory size and includes one additional parameter $R = \text{SearchRadius}$

controlling the set \mathcal{R} of conjugating factors. Namely, before running the attack we precompute \mathcal{R} as the set of nontrivial elements in the ball \mathcal{B}_R of radius R in G . Thus, for $R = 3$, our attack covers all of the attacks listed in [GKL15] in the sense that the percentage of successes will be not smaller than the one in the listed attacks. We will also refer to the set \mathcal{B}_R as the *search ball* of the attack. Our source code for the attack written in GAP can be found in the GitHub repository [KMS24].

6.1 Complexity estimate for the LBA

Suppose we are given an instance of SCSP with the initial value of the length function $l(\overline{ab}^{-1}) = L$. To estimate the worst case complexity of LBA we observe that each step of the attack can be parameterized by a word over \mathcal{R} of length at most L since every additional conjugator $r \in \mathcal{R}$ reduces the length function by at least 1. Therefore, the total number of steps that the attack can take is at most

$$\sum_{i=0}^L |\mathcal{R}|^i = \frac{|\mathcal{R}|^{L+1} - 1}{|\mathcal{R}| - 1}. \quad (10)$$

Thus, the worst time complexity will be exponential in L . In practice the number of steps is much smaller as the worst case complexity estimate assumes that each additional conjugator $r \in \mathcal{R}$ will decrease the length function exactly by 1, so that we have to go through all possible branches of the algorithm. However, if r does not reduce the length, then the whole branch of the algorithm will be terminated at this stage.

In our implementation of LBA, as stated above, we use $\mathcal{R} = \mathcal{B}_R$ for some radius $R \geq 1$. Estimate (10) suggests that the LBA may generally work faster for larger values of R for groups that have smaller \mathcal{B}_R (for example, if the group grows subexponentially or when the generators are involutions). However, we observed that this is not a sufficient condition as we found some instances of SCSP in $IMG(z^2 + i)$ with $|r| = 20$, $|a| = 10$, and $R = 5$ (with $|\mathcal{B}_5| = 421$) that were terminated due to longer than 24 hour computation time.

6.2 Length functions for LBA

In the implementation of LBA, the choice of the length function is important (see, for example, [GKT⁺05, HT10]). Historically, the sum of the word lengths of the elements of was the main length function used in LBA attacks in the literature. However, since we propose to use nucleus portraits to uniquely identify elements of contracting groups, this length function is not available in this situation. Instead, we propose 2 length functions that can be computed from nucleus portraits of the involved elements.

6.2.1 Portrait depth length function

The main length function that we study here is the *portrait depth length function*:

$$l_d((g_1, \dots, g_n)) = \sum_{i=1}^n \partial(g_i), \quad (11)$$

which is just the sum of the depths of the nucleus portraits of all the g_i 's.

6.2.2 Portrait boundary size length function

Another candidate for complexity function when group elements are given as nucleus portraits is the *portrait boundary size length function* based on the number of leaves of a nucleus portrait $s(g)$ as defined in Definition 4.4:

$$l_b((g_1, \dots, g_n)) = \sum_{i=1}^n s(g_i). \quad (12)$$

While the range of values of this function is significantly larger than the one for the portrait depth length function (for the same input size), our experimental results showed that using l_b for LBA was infeasible for even relatively short tuples $(g_1, \dots, g_n) \in G^n$. The attack took too much time as there was a lot of branching of the algorithm involved.

Algorithm 1 The function LengthBasedAttack implementing the LBA

```

1: function LENGTHBASEDATTACK( $a, b, SearchRadius$ )
2:    $B \leftarrow$  (List of nontrivial elements in  $G$  of length  $\leq SearchRadius$ )  ▷ compute conjugator
   factors
3:    $InitialConjugator \leftarrow 1$   ▷ Initiate the candidate for the conjugator
4:    $InitialLength \leftarrow$  LENGTH( $a^{InitialConjugator} b^{-1}$ )

5:   function LENGTHBASEDATTACKRECURSIVE( $CurrentConjugator, CurrentLength$ )
6:     if  $CurrentLength = 0$  then
7:       return  $CurrentConjugator$ 
8:     end if
9:     for  $ConjugatorFactor$  in  $B$  do
10:       $NewConjugator \leftarrow CurrentConjugator * ConjugatorFactor$ 
11:       $NewSize \leftarrow$  LENGTH( $a^{NewConjugator} b^{-1}$ )
12:      if  $NewLength < CurrentLength$  then
13:         $Outcome \leftarrow$  LENGTHBASEDATTACKRECURSIVE( $NewConjugator, NewSize$ )
14:        if  $Outcome \neq$  Fail then
15:          return Outcome
16:        end if
17:      end if
18:    end for
19:    return Fail
20:  end function

21:  return LENGTHBASEDATTACKRECURSIVE( $InitialConjugator, InitialLength, SearchRadius$ )
22: end function

```

7 Experimental Results for LBA against SCSP in Contracting Groups

In this section we present experimental results for LBA against SCSP when group elements are only provided as nucleus portraits. The results incorporate variations in parameters of the SCSP

and LBA such as the size of conjugator and radius R of search ball \mathcal{B}_R among others. Furthermore, groups are chosen to ensure variation in nucleus size and in complexity of algebraic structure to identify conspicuous associations between these parameters and degree of success of the attacks. In this regard, we performed iterations for groups with nucleus size ranging from 5 to 26 and the algebraic structure varying from virtually abelian groups to more complex group structures. Some of the selected groups are taken from the classification of groups generated by 3-state automata over 2-letter alphabet [BGK⁺08]. In that paper every 3-state automaton over 2-letter alphabet is assigned a number m from 1 to 5832 and is denoted by \mathcal{A}_m . The group generated by \mathcal{A}_m is denoted by $\mathbb{G}(\mathcal{A}_m)$. Note, that the notation in [BGK⁺08] was different: unlike in the present paper, left actions were used there, which explains the difference in group descriptions (e.g., the groups $(\mathbb{Z} \times \mathbb{Z}) \rtimes C_2$ and $\mathbb{Z} \wr C_2$, where C_2 is the acting group, are denoted in [BGK⁺08] by $C_2 \rtimes (\mathbb{Z} \times \mathbb{Z})$ and $C_2 \wr \mathbb{Z}$, respectively). Additionally, all words in generators given in [BGK⁺08] need to be reversed in the notation of the present paper.

7.1 Notation for the attack

7.1.1 Simultaneous Conjugacy Search Problem (SCSP)

We will describe our results using the notation for SCSP given in the Introduction. Namely, we assume that we have two n -tuples (a_1, a_2, \dots, a_n) and (b_1, b_2, \dots, b_n) of elements of G that are conjugate by an element $r \in G$ (i.e., $a_i^r = b_i$ for $1 \leq i \leq n$). Following the description of LBA in Section 6, radius of the search ball \mathcal{B}_R is referred to as R .

7.1.2 Runtime

We report the time taken for iterations as GAP-seconds. This is the *runtime* in GAP (recorded in milliseconds) converted into seconds and rounded to the nearest integer. As per GAP-Reference Manual, Section 7.6, this is the time spent by the Central Processing Unit (CPU) with GAP functions (without child processes). We note that both, the overall time taken and GAP-seconds for an iteration vary depending on the system specifications.

Table 4 provides specifications of the system used for running the LBA and a comparison of runtime in GAP with the actual time taken for the computations.

Processor-specifications	Intel(R) Core(TM)i7-5500U CPU @ 2.40GHz				
RAM	Installed RAM = 8.00 GB - Usable RAM = 7.89 GB				
System type	64-bit operating system, x64 - based processor				
GAP-Runtime	263562	206844	253406	116250	191781
Overall time (ms)	264938	207710	253660	116424	191931
Time difference (ms)	1376	866	254	174	150
Time difference as % of GAP- Runtime	0.52%	0.42%	0.10 %	0.15 %	0.08%

Table 4: Comparison of GAP-Runtime with overall time taken in milliseconds to complete computations.

7.1.3 Parameters

We use the following set of parameters for each computation (corresponding to each table entry) recorded in the following Subsections:

- In all experiments in this section we use the portrait depth length function l_d defined in (11).
- In all experiments we set $n = 5$, i.e., computations are performed using randomly generated 5-tuples (a_1, a_2, \dots, a_5) from the respective groups.
- Random elements of groups are generated by random freely reduced words over the symmetric generating sets of groups with additional general reduction that for each generator s of a group of order 2, s^{-1} is replaced by s . Additionally, in the case of Grigorchuk group and Universal Grigorchuk group, the random words are reduced further using the fact that $\langle b, c, d \rangle \cong K_4$ to the standard reduced words of the form $(*)a * a * \dots * a(*)$ with $* \in \{b, c, d\}$.
- The reduced word length of each a_i , that we denote by $|a_i|$, was set to either 10 or 100.
- Based upon the automaton group, the radius R of search ball \mathcal{B}_R is varied to analyze efficacy of the attack. Overall, the search radius varies from 1 to 5 in our study. Larger values of R increase the success rate of the attack but considerably slow down the calculations.
- The reduced word length $|r|$ of the conjugator r is varied from 5 up to 100 to examine effectiveness of the attack.

7.2 The group $\mathbb{G}(\mathcal{A}_{750}) \cong \mathbb{Z} \wr C_2$

The automaton generating this group is shown in Figure 8 and is of exponential growth in the sense of Sidki. The nucleus size $|\mathcal{N}|$ is 9. The group itself is virtually abelian with all the sections of generators belonging to an abelian subgroup $\langle a, c \rangle$. The nucleus \mathcal{N} can be found using `AutomGrp` as follows:

```
G_750:= AutomatonGroup("a = (c,a)(1,2), b = (c,a), c = (a,a)");
< a, b, c >
gap> GeneratingSetWithNucleus(G_750);
[ 1, a, b, c, a^-1, b^-1, c^-1, c*a^-1, a*c^-1 ]
```

Experimental results for LBA attack for $\mathbb{G}(\mathcal{A}_{750})$ are recorded in Table 5.

We note that, given the parameters, the smallest non-trivial ball \mathcal{B}_1 (that only contains the generators and their inverses) succeeds about half of the time in finding the conjugator r . Moreover, increasing the radius R of the search ball \mathcal{B}_R from 1 to 2 increases the success of attack by at least 20 percentage points resulting in at least 70 percent success. This shows that the attack works very well for this contracting group. Given the very high success rate across our choice of parameters for SCSP, we have omitted results for search balls with larger radii for this group. The time taken to perform iterations for \mathcal{A}_{750} is relatively small compared to most other contracting groups in our study (when compared with similar test parameters of course).

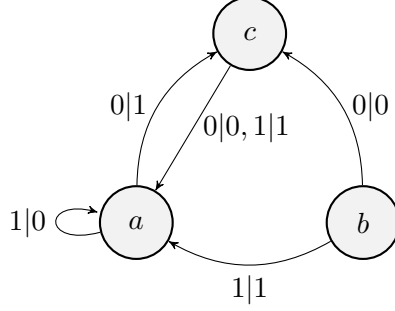

Figure 8: Automaton \mathcal{A}_{750} generating the group $\mathbb{Z} \wr C_2$

Automaton group	$\mathbb{G}(\mathcal{A}_{750}) \cong \mathbb{Z} \wr C_2$					
Reduced word length of conjugator r	20		30		100	
Radius R of the search ball \mathcal{B}_R	1	2	1	2	1	2
Percentage of success (%)	70.00	96.67	60.00	86.67	46.67	70.00
GAP-Seconds (average)	10.87	13.53	8.26	965.33	157.73	525.63

Table 5: Average time taken and success rate for 30 iterations each for different radii of search ball \mathcal{B}_R and reduced word length of conjugator for the contracting automaton group $\mathbb{Z} \wr C_2$ generated by \mathcal{A}_{750} ; $|a| = 10$ and $n = 5$ for all iterations.

7.3 The group $\mathbb{G}(\mathcal{A}_{775}) \cong \text{IMG} \left(\left(\frac{z-1}{z+1} \right)^2 \right) \rtimes C_2$

The automaton generating this group is shown in Figure 9 and is of exponential growth in the sense of Sidki. The nucleus size $|\mathcal{N}|$ is 8. The nucleus \mathcal{N} can be found using `AutomGrp` as follows:

```

G_775 := AutomatonGroup("a = (a,a)(1,2), b = (c,b), c = (a,a)");
< a, b, c >
gap> GeneratingSetWithNucleus(G_775);
[ 1, a, b, c, a*b, a*c, b^-1*a^-1, a*b^-1*a^-1 ]

```

Experimental results for LBA attack for $\mathbb{G}(\mathcal{A}_{775})$ are recorded in Table 6.

Although both contracting groups, generated by automata \mathcal{A}_{750} and \mathcal{A}_{775} have comparable nucleus sizes $|\mathcal{N}|$, there is a notable difference in the success of the LBA. This is evident by little to no success when the conjugator has a relatively large reduced word length such as $|r| = 100$. Here we observe that although there is increase in the success rate and time taken for LBA as we increase the search radius R , the pairs of search balls $\{\mathcal{B}_2, \mathcal{B}_3\}$, and $\{\mathcal{B}_4, \mathcal{B}_5\}$ produce very similar results.

Given the low success rate of LBA for the aforementioned parameters, we performed further simulations for a different set of parameters that have significantly greater reduced length $|a|$ of conjugated elements. These results are recorded in Table 7. In our simulations LBA is completely unsuccessful for these parameters for $\mathbb{G}(\mathcal{A}_{775})$.

Automaton group	$\mathbb{G}(\mathcal{A}_{775}) \cong \text{IMG} \left(\left(\frac{z-1}{z+1} \right)^2 \right) \rtimes C_2$											
Reduced word length of conjugator r	20				30				100			
Radius R of the search ball \mathcal{B}_R	2	3	4	5	2	3	4	5	2	3	4	5
Percentage of success (%)	10	13.33	46.67	46.67	13.33	13.33	33.33	36.67	0	0	3.33	0.00
GAP-seconds (average)	3.7	9.97	32.67	47.9	7.23	10.93	62.5	83.8	11.3	28.23	72.47	234

Table 6: Average time taken and success rate for 30 iterations each for different radii of search ball \mathcal{B}_R and reduced word length of conjugator for the automaton group $\text{IMG} \left(\left(\frac{z-1}{z+1} \right)^2 \right) \rtimes C_2$ generated by \mathcal{A}_{775} ; $|a| = 10$ and $n = 5$ for all iterations.

Automaton group	$\mathbb{G}(\mathcal{A}_{775}) \cong \text{IMG} \left(\left(\frac{z-1}{z+1} \right)^2 \right) \rtimes C_2$		
Reduced word length of conjugator r	100	100	100
Reduced word length of conjugated elements, $ a $	100	100	100
Radius R of the search ball \mathcal{B}_R	2	3	4
Percentage of success (%)	0	0	0
GAP-seconds (average)	64.6	274.17	3009.33

Table 7: Average time taken and success rate for 30 iterations each for different radii of search ball \mathcal{B}_R and SCSP parameters for the automaton group $\text{IMG} \left(\left(\frac{z-1}{z+1} \right)^2 \right) \rtimes C_2$ generated by \mathcal{A}_{775} . Number of conjugated elements $n = 5$ for all iterations.

7.4 The group $\mathbb{G}(\mathcal{A}_{2277}) \cong (\mathbb{Z} \times \mathbb{Z}) \rtimes C_2$

The automaton generating this group is shown in Figure 10 and is of exponential growth in the sense of Sidki. The nucleus size $|\mathcal{N}|$ is 16. The group contains \mathbb{Z}^2 as a subgroup of index 2. The nucleus \mathcal{N} can be found using `AutomGrp` as follows:

```
gap> G_2277:= AutomatonGroup("a = (c,c)(1,2), b = (a,a)(1,2), c = (b,a)");
< a, b, c >
gap> GeneratingSetWithNucleus(G_2277);
[ 1, a, b, c, a*b, c*a, b*c, a*c, c*b, b*a, b*c*a, a*b*c, c*a*b, a*c*a, c*a*c, c*b*c ]
```

Experimental results for LBA attack for $\mathbb{G}(\mathcal{A}_{2277})$ are recorded in Table 8.

Similarly to $\mathbb{G}(\mathcal{A}_{750})$, the smallest non-trivial ball \mathcal{B}_1 succeeds every time in finding the conjugator r . Given the hundred percent success rate across all SCSP parameters displayed in the Table 8, no further simulations were performed using search balls with larger radii.

7.5 The group $\mathbb{G}(\mathcal{A}_{2287}) \cong \text{IMG} \left(\frac{z^2+2}{1-z^2} \right)$

The automaton generating this group is shown in Figure 11 and is of exponential growth in the sense of Sidki. The nucleus size $|\mathcal{N}|$ is 26 which is the largest among groups generated by 3-state automata in our

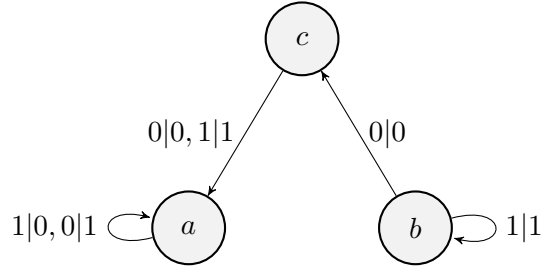

Figure 9: Automaton \mathcal{A}_{775} generating the group $IMG\left(\left(\frac{z-1}{z+1}\right)^2\right) \rtimes C_2$.

Automaton group	$\mathbb{G}(\mathcal{A}_{2277}) \cong (\mathbb{Z} \times \mathbb{Z}) \rtimes C_2$		
Reduced word length of conjugator r	20	30	100
Radius R of the search ball \mathcal{B}_R	1	1	1
Percentage of success (%)	100	100	100
GAP-seconds (average)	3.93	11.3	23.97

Table 8: Average time taken and success rate for 30 iterations each for different radii of search ball \mathcal{B}_R and SCSP parameters for the automaton group $(\mathbb{Z} \times \mathbb{Z}) \rtimes C_2$ generated by \mathcal{A}_{2277} ; $|a| = 10$ and $n = 5$ for all iterations.

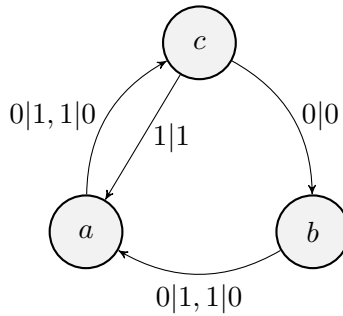

Figure 10: Three-state Automaton \mathcal{A}_{2277} generating the group $(\mathbb{Z} \times \mathbb{Z}) \rtimes C_2$

Automaton group	$\mathbb{G}(\mathcal{A}_{2287}) \cong IMG\left(\frac{z^2+2}{1-z^2}\right)$		
Reduced word length of conjugator r	5	10	20
Radius of the search ball \mathcal{B}_R	2	2	2
Percentage of success (%)	36.67	3.33	0.00
GAP-seconds (average)	103.13	154.67	235.7

Table 9: Average time taken and success rate for 30 iterations each for different radii of search ball \mathcal{B}_r and reduced word length of conjugator for the contracting group $IMG\left(\frac{z^2+2}{1-z^2}\right)$ generated by automaton \mathcal{A}_{2287} ; $|a| = 10$ and $n = 5$ for all iterations.

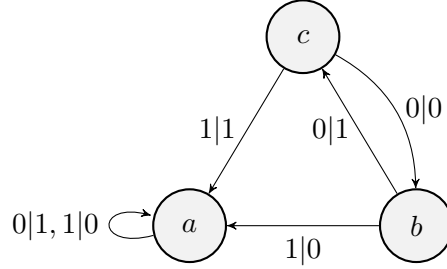

Figure 11: Automaton \mathcal{A}_{2287} generating the group $IMG\left(\frac{z^2+2}{1-z^2}\right)$

study. There is not much information about the algebraic structure of this group. The nucleus \mathcal{N} can be found using `AutomGrp` as follows:

```
gap> G_2287:= AutomatonGroup("a = (a,a)(1,2), b = (c,a)(1,2), c = (b,a)");
< a, b, c >
gap> GeneratingSetWithNucleus(G_2287);
[ 1, a, b, c, b^-1, c^-1, a*b, a*c, b^-1*a^-1, c^-1*a^-1, a*b^-1, a*c^-1,
  b*a^-1, c*a^-1, a*b^-1*a^-1, a*c^-1*a^-1, a*b*a^-1, a*c*a^-1, b*a*c^-1,
  a*b*a*c^-1, c*a^-1*b^-1*a^-1, a*c*a^-1*b^-1*a^-1, b^-1*c, c^-1*b, a*b^-1*c,
  a*c^-1*b ]
```

Experimental results for LBA attack for $\mathbb{G}(\mathcal{A}_{2287})$ are recorded in Table 9. Among the 3-state automaton generated groups in our study, the simulations take the greatest time to complete for this group. One reason for this is the big nucleus size $|\mathcal{N}|$. We note that the attack is not successful for modest SCSP parameters. The simulations involving greater search radius R and conjugator reduced length $|r|$ were terminated after 24 hours. We conclude that this group has the highest cost of running LBA attack simulations.

7.6 The group $IMG(z^2 + i)$

The group G generated by a 4-state automaton in Figure 12 of bounded growth in the sense of Sidki, is isomorphic to $IMG(z^2 + i)$ and was shown to have intermediate growth by Bux and Pérez in [BP06]. A finite L -presentation of G was explicitly calculated by Grigorchuk, Šunić, and the third author in [GSS07]. In the last paper it was also shown that G is regular branch. The nucleus \mathcal{N} has size 4 and can be found using `AutomGrp` as follows:

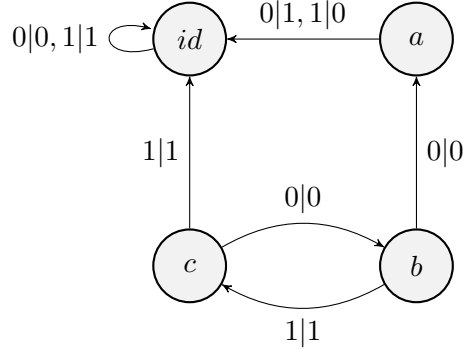

Figure 12: Automaton generating the group $IMG(z^2 + i)$

```
G := AutomatonGroup("a = (1,1)(1,2), b = (a,c), c = (b,1)");
< a, b, c >
gap> GeneratingSetWithNucleus(G);
[ 1, a, b, c ]
```

Experimental results for LBA attack for $IMG(z^2 + i)$ are recorded in Table 10. We also note that we ran some tests for this group for $|r| = 20$, $|a| = 10$, and $R = 5$ and observed a higher success rate (up to 30%), but also a large time variability. While some of the runs finished successfully, there was one run that we had to terminate after about 50 hours of computation without. The initial length function value for that instance was 38.

Automaton group	$IMG(z^2 + i)$					
Reduced word length of conjugator r	10		20		30	
Radius R of the search ball \mathcal{B}_R	3	4	3	4	3	4
Percentage of success (%)	16.67	33.33	0.00	3.33	0.00	0.00
GAP-seconds (average)	42.27	115.63	50.6	660.2	111.87	355.1

Table 10: Average time taken and success rate for 30 iterations each for different radii of search ball \mathcal{B}_R and reduced word length of conjugator for the contracting group $IMG(z^2 + i)$; $|a| = 10$ and $n = 5$ for all iterations.

7.7 Grigorchuk group \mathcal{G}

Grigorchuk group \mathcal{G} is with no doubt the most famous and studied automaton group. We refer the reader to [Gri05] for a detailed survey of properties and problems related to this group. We will point out here that it is not a linear group as a group of intermediate growth. It was suggested as a possible platform group for AAG cryptosystem in [GG19b]. It is generated by the bounded (in the sense of Sidki) automaton displayed in Figure 2 and has the nucleus of size 5. The nucleus \mathcal{N} can be found using `AutomGrp` as follows:

```
gap> G := AG_Groups.GrigorchukGroup;
< a, b, c, d >
gap> AssignGeneratorVariables(G);
```

Automaton group	Grigorchuk group \mathcal{G}								
Reduced word length of conjugator r	20			30			100		
Radius R of the search ball \mathcal{B}_R	2	3	4	2	3	4	2	3	4
Percentage of success (%)	0.00	3.33	0.00	0.00	3.33	3.33	0.00	0.00	0.00
GAP-seconds (average)	3.63	14.5	40.53	4.5	22.23	39.8	6.7	13.9	88.13

Table 11: Average time taken and success rate for 30 iterations each for different radii of search ball \mathcal{B}_R and reduced word length of conjugator for the Grigorchuk group; $|a| = 10$ and $n = 5$ for all iterations.

```
#I Assigned the global variables [ a, b, c, d ]
gap> GeneratingSetWithNucleus(G);
[ 1, a, b, c, d ]
```

Experimental results for LBA attack for \mathcal{G} are recorded in Table 11. Given the wide interest in Grigorchuk group, we ran further simulations for additional set of parameters that have significantly greater reduced length $|a|$ of conjugated elements. These results are recorded in Table 12. In these simulations LBA fails to find a conjugator for SCSP.

Automaton group	Grigorchuk Group		
Reduced word length of conjugator r	100	100	100
Reduced word length of conjugated elements, $ a $	100	100	100
Radius R of the search ball \mathcal{B}_R	2	3	4
Percentage of success (%)	0.00	0.00	0.00
GAP-seconds (average)	8.2	59.53	200.2

Table 12: Average time taken and success rate for 30 iterations each for different radii of search ball \mathcal{B}_R and SCSP parameters for the Grigorchuk group. Number of conjugated elements $n = 5$ for all iterations.

7.8 Universal Grigorchuk group \mathcal{G}_U

The Universal Grigorchuk group \mathcal{G}_U was introduced in [Gri05, Problem 9.5] as the group that has all Grigorchuk groups G_ω from [Gri84] as quotients. Therefore, it is not a linear group as it has a quotient \mathcal{G} of intermediate growth. Moreover, it is generated by an automaton of exponential growth, so the results from [BBSZ13] cannot be used to construct a conjugator in a larger group. It was observed by Nekrashevych that \mathcal{G}_U has a self-similar action on the 6-ary tree defined by the following wreath recursion:

$$\begin{aligned}
a &= (1, 1, 1, 1, 1, 1)(1, 4)(2, 5)(3, 6), \\
b &= (a, a, 1, b, b, b), \\
c &= (a, 1, a, c, c, c), \\
d &= (1, a, a, d, d, d).
\end{aligned}$$

The nucleus \mathcal{N} can be found using `AutomGrp` as follows:

```

gap> G_U := AG_Groups.UniversalGrigorchukGroup;
< a, b, c, d >
gap> GeneratingSetWithNucleus(G_U);
[ 1, a, b, c, d ]

```

Experimental results for LBA attack for \mathcal{G}_U are recorded in Table 13. We note that due to the large degree of the tree on which \mathcal{G}_U acts, the simulations for this group are the most time consuming among all contracting groups in our study. Some of the reported simulations took over 48 hours to complete. Therefore, the experimental results are reported for relatively small range of parameters.

Automaton group	Universal Grigorchuk Group			
	5		7	
Reduced word length of conjugator r				
Radius R of the search ball \mathcal{B}_R	2	3	3	4
Percentage of success (%)	0.00	50.00	0.00	30.00
GAP-seconds (average)	458.79	2174.71	4009.83	9408.09

Table 13: Average time taken and success rate for 30 iterations each for different radii of search ball \mathcal{B}_R and reduced word length of conjugator for the Universal Grigorchuk group; $|a| = 10$ and $n = 5$ for all iterations.

7.9 Basilica group $\mathcal{B} \cong IMG(z^2 - 1)$

Basilica group $\mathcal{B} = IMG(z^2 - 1)$ is among the automaton groups proposed as platform for AAG protocol in [GG19b]. The group was first studied in [GŻ02a, GŻ02b] and has been an important example in many situations. It is torsion free, has exponential growth, amenable but not elementary (and not even subexponentially) amenable [BV05], has trivial Poisson boundary, is weakly branch, and has many other interesting properties. It is generated by bounded automaton in the The automaton generating the Basilica group is shown in Figure 13.

The nucleus \mathcal{N} can be found in GAP using the package `AutomGrp` as follows:

```

gap> B := AutomatonGroup("u = (v,1)(1,2), v = (u,1)");
< u, v >
gap> GeneratingSetWithNucleus(B);
[ 1, u, v, u^-1, v^-1, u^-1*v, v^-1*u ]

```

Experimental results for LBA attack for \mathcal{B} are recorded in Table 14, which shows that the attack had no success for conjugatros of length at least 20. We note that there is no essential time difference for computations with search radius 2 even when the reduced word length of conjugator r is increased from 30 to 100. This is because in most cases iterations terminate with relatively little search for the conjugator since very few (if any) elements in \mathcal{B}_R tend to decrease the value of the length function.

Moreover, the time taken for LBA iterations to conclude significantly increases as the radius of search ball \mathcal{B}_R is increased from 2 to 3. In particular, for $|r| = 30$ and $R = 3$, a set of 10 iterations was terminated after running for over 60 hours without conclusion.

Automaton group	Basilica Group \mathcal{B}					
Reduced word length of conjugator r	10		20		30	100
Radius R of the search ball \mathcal{B}_R	2	3	2	3	2	2
Percentage of success (%)	6.67	33.33	0.00	0.00	0.00	0.00
GAP-seconds (average)	41.04	6871.21	62.6	5089.57	80.1	51.77

Table 14: Average time taken and success rate for 30 iterations each for different radii of search ball \mathcal{B}_R and reduced word length of conjugator for the Basilica group; $|a| = 10$ and $n = 5$ for all iterations.

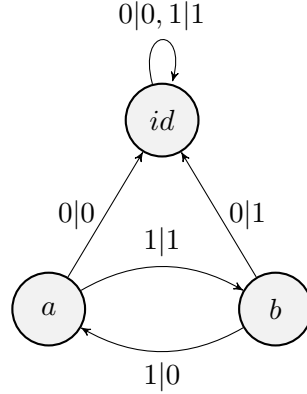

Figure 13: Automaton $\mathcal{A}_{\mathcal{B}}$ generating the Basilica group.

References

- [AAG99] I. Anshel, M. Anshel, and D. Goldfeld. An algebraic method for public-key cryptography. *Math. Res. Lett.*, 6:287–291, 1999.
- [BBSZ13] Ievgen V. Bondarenko, Natalia V. Bondarenko, Said N. Sidki, and Flavia R. Zapata. On the conjugacy problem for finite-state automorphisms of regular rooted trees. *Groups Geom. Dyn.*, 7(2):323–355, 2013. With an appendix by Raphaël M. Jungers.
- [BGK⁺08] Ievgen Bondarenko, Rostislav Grigorchuk, Rostyslav Kravchenko, Yevgen Muntyan, Volodymyr Nekrashevych, Dmytro Savchuk, and Zoran Šunić. On classification of groups generated by 3-state automata over a 2-letter alphabet. *Algebra Discrete Math.*, (1):1–163, 2008. (available at <http://arxiv.org/abs/0803.3555>).
- [BM20] Laurent Bartholdi and Ivan Mitrofanov. The word and order problems for self-similar and automata groups. *Groups Geom. Dyn.*, 14(2):705–728, 2020.
- [BP06] Kai-Uwe Bux and Rodrigo Pérez. On the growth of iterated monodromy groups. In *Topological and asymptotic aspects of group theory*, volume 394 of *Contemp. Math.*, pages 61–76. Amer. Math. Soc., Providence, RI, 2006. (available at <http://www.arxiv.org/abs/math.GR/0405456>).
- [BV05] Laurent Bartholdi and Bálint Virág. Amenability via random walks. *Duke Math. J.*, 130(1):39–56, 2005. (available at <http://arxiv.org/abs/math.GR/0305262>).
- [BZKT18] Adi Ben-Zvi, Arkadiusz Kalka, and Boaz Tsaban. Cryptanalysis via algebraic spans. In *Advances in cryptology—CRYPTO 2018. Part I*, volume 10991 of *Lecture Notes in Comput. Sci.*, pages 255–274. Springer, Cham, 2018.

- [Deh04] Patrick Dehornoy. Braid-based cryptography. In *Group theory, statistics, and cryptography*, volume 360 of *Contemp. Math.*, pages 5–33. Amer. Math. Soc., Providence, RI, 2004.
- [DKRH16] Volker Diekert, Manfred Kufleitner, Gerhard Rosenberger, and Ulrich Hertrampf. *Discrete algebraic methods*. De Gruyter Textbook. De Gruyter, Berlin, 2016. Arithmetic, cryptography, automata and groups.
- [GG19a] R.I. Grigorchuk and D. Grigoriev. Key agreement based on automaton groups. *Groups Complex. Cryptol.*, 11(2):77–81, 2019.
- [GG19b] Rostislav Grigorchuk and Dima Grigoriev. Key agreement based on automaton groups. *Groups Complex. Cryptol.*, 11(2):77–81, 2019.
- [Gil14] Pierre Gillibert. The finiteness problem for automaton semigroups is undecidable. *Internat. J. Algebra Comput.*, 24(1):1–9, 2014.
- [Gil18] Pierre Gillibert. An automaton group with undecidable order and Engel problems. *J. Algebra*, 497:363–392, 2018.
- [GKL15] David Garber, Delaram Kahrobaei, and Ha T. Lam. Length-based attacks in polycyclic groups. *J. Math. Cryptol.*, 9(1):33–43, 2015.
- [GKT⁺05] D. Garber, S. Kaplan, M. Teicher, B. Tsaban, and U. Vishne. Probabilistic solutions of equations in the braid group. *Adv. in App. Math.* 35, pages 323–334, 2005.
- [GKT⁺06] D. Garber, S. Kaplan, M. Teicher, B. Tsaban, and U. Vishne. Length-based conjugacy search in the braid group. *Contemp. Math.* 418, pages 75–87, 2006.
- [Gri80] R. I. Grigorchuk. On Burnside’s problem on periodic groups. *Funktsional. Anal. i Prilozhen.*, 14(1):53–54, 1980.
- [Gri84] R. I. Grigorchuk. Degrees of growth of finitely generated groups and the theory of invariant means. *Izv. Akad. Nauk SSSR Ser. Mat.*, 48(5):939–985, 1984.
- [Gri05] Rostislav Grigorchuk. Solved and unsolved problems around one group. In *Infinite groups: geometric, combinatorial and dynamical aspects*, volume 248 of *Progr. Math.*, pages 117–218. Birkhäuser, Basel, 2005.
- [GSŠ07] Rostislav Grigorchuk, Dmytro Savchuk, and Zoran Šunić. The spectral problem, substitutions and iterated monodromy. In *Probability and mathematical physics*, volume 42 of *CRM Proc. Lecture Notes*, pages 225–248. Amer. Math. Soc., Providence, RI, 2007.
- [GW00] R. I. Grigorchuk and J. S. Wilson. The conjugacy problem for certain branch groups. *Tr. Mat. Inst. Steklova*, 231(Din. Sist., Avtom. i Beskon. Gruppy):215–230, 2000.
- [GZ91] M. Garzon and Y. Zalcstein. The complexity of Grigorchuk groups with application to cryptography. *Theoret. Comput. Sci.*, 88(1):83–98, 1991.
- [GŽ02a] Rostislav I. Grigorchuk and Andrzej Żuk. On a torsion-free weakly branch group defined by a three state automaton. *Internat. J. Algebra Comput.*, 12(1-2):223–246, 2002.
- [GŽ02b] Rostislav I. Grigorchuk and Andrzej Żuk. Spectral properties of a torsion-free weakly branch group defined by a three state automaton. In *Computational and statistical group theory (Las Vegas, NV/Hoboken, NJ, 2001)*, volume 298 of *Contemp. Math.*, pages 57–82. Amer. Math. Soc., Providence, RI, 2002.
- [Hab23] Maggie E. Habeeb. Oblivious transfer using non-abelian groups. In *Frontiers in industrial and applied mathematics*, volume 410 of *Springer Proc. Math. Stat.*, pages 29–36. Springer, Singapore, 2023.

- [HT02] J. Hughes and A. Tannenbaum. Length-based attacks for certain group based encryption rewriting systems. *Workshop SECI02 Securite de la Communication sur Internet*, 2002.
- [HT10] M. Hock and B. Tsaban. Solving random equations in Garside groups using length functions. *Combinatorial and Geometric Group Theory*, pages 149–169, 2010.
- [KFN23] Delaram Kahrobaei, Ramon Flores, and Marialaura Noce. Group-based cryptography in the quantum era. *Notices of the American Mathematical Society*, 70(5):752–763, 2023.
- [KFN⁺24] D. Kahrobaei, R. Flores, M. Noce, M. Habeeb, and C. Battarbee. *Applications of Group Theory in Cryptography: Post-quantum Group-based Cryptography*. The Mathematical Surveys and Monographs series of the American Mathematical Society, 2024.
- [KK06] Delaram Kahrobaei and Bilal Khan. Nis05-6: A non-commutative generalization of elgamal key exchange using polycyclic groups. In *IEEE Globecom 2006*, pages 1–5, 2006.
- [KK12] D. Kahrobaei and C. Koupparis. Non-commutative digital signatures using non-commutative groups. *Groups, Complexity, Cryptology*, 4, 2012.
- [KLC⁺00] K. H. Ko, S. J. Lee, J. H. Cheon, J. W. Han, J. Kang, and C. Park. New public-key cryptosystem using braid groups. *Advances in cryptology — CRYPTO 2000 (Santa Barbara, CA), LNCS, vol. 1880*, pages 166–183, 2000.
- [KMS24] D. Kahrobaei, A. Malik, and D. Savchuk. LBA: A variant of the length-based attack on the simultaneous conjugacy search problem in contracting groups. https://github.com/Arsalan-A-M/LBA_SCSP_Contracting_Groups, August 2024.
- [KMU14] M. Kreuzer, A. D. Myasnikov, and A. Ushakov. A linear algebra attack to group-ring-based key exchange protocols. In *Applied cryptography and network security*, volume 8479 of *Lecture Notes in Comput. Sci.*, pages 37–43. Springer, Cham, 2014.
- [KNR24] Delaram Kahrobaei, Marialaura Noce, and Emanuele Rodaro. Applications of automaton groups in cryptography. *International Journal of Computer Mathematics: Computer System Theory*, pages 96–106, 2024.
- [Leo98] Yu. G. Leonov. The conjugacy problem in a class of 2-groups. *Mat. Zametki*, 64(4):573–583, 1998.
- [LMU10] Igor Lysenok, Alexei Myasnikov, and Alexander Ushakov. The conjugacy problem in the Grigorchuk group is polynomial time decidable. *Groups Geom. Dyn.*, 4(4):813–833, 2010.
- [MSU11] Alexei Myasnikov, Vladimir Shpilrain, and Alexander Ushakov. *Non-commutative cryptography and complexity of group-theoretic problems*, volume 177 of *Mathematical Surveys and Monographs*. American Mathematical Society, Providence, RI, 2011. With an appendix by Natalia Mosina.
- [MSU21] Mitra Modi, Mathew Seedhom, and Alexander Ushakov. Linear time algorithm for the conjugacy problem in the first Grigorchuk group. *Internat. J. Algebra Comput.*, 31(4):789–806, 2021.
- [MU07] Alex D. Myasnikov and Alexander Ushakov. Length based attack and braid groups: cryptanalysis of Anshel-Anshel-Goldfeld key exchange protocol. In *Public key cryptography—PKC 2007*, volume 4450 of *Lecture Notes in Comput. Sci.*, pages 76–88. Springer, Berlin, 2007.
- [MU08] Alexei G. Myasnikov and Alexander Ushakov. Random subgroups and analysis of the length-based and quotient attacks. *J. Math. Cryptol.*, 2(1):29–61, 2008.
- [Nek05] Volodymyr Nekrashevych. *Self-similar groups*, volume 117 of *Mathematical Surveys and Monographs*. American Mathematical Society, Providence, RI, 2005.
- [Nek10] Volodymyr Nekrashevych. Free subgroups in groups acting on rooted trees. *Groups Geom. Dyn.*, 4(4):847–862, 2010.

- [Pet03] G. Petrides. Cryptanalysis of the public key cryptosystem based on the word problem on the Grigorchuk groups. In *Cryptography and coding*, volume 2898 of *Lecture Notes in Comput. Sci.*, pages 234–244. Springer, Berlin, 2003.
- [Roz98] A. V. Rozhkov. The conjugacy problem in an automorphism group of an infinite tree. *Mat. Zametki*, 64(4):592–597, 1998.
- [RST07] D. Ruinskiy, A. Shamir, and B. Tsaban. Length-based cryptanalysis: the case of Thompson’s group. *Journal of Mathematical Cryptology* 1, pages 359–372, 2007.
- [Sav03] Dmytro M. Savchuk. On word problem in contracting automorphism groups of rooted trees. *Visn. Kyiv. Univ. Ser. Fiz.-Mat. Nauky*, (1):51–56, 2003.
- [Sid87] Said Sidki. On a 2-generated infinite 3-group: subgroups and automorphisms. *J. Algebra*, 110(1):24–55, 1987.
- [Sid04] Said Sidki. Finite automata of polynomial growth do not generate a free group. *Geom. Dedicata*, 108:193–204, 2004.
- [SSS24] Dmytro Savchuk, Luciana Scuderi, and Kerry Seekamp. Portrait-based attack on the simultaneous conjugacy problem in contracting groups acting on a binary tree, GitHub repository. <https://github.com/11scuderi/Portrait-Based-Attack-on-SCSP-in-Contracting-Groups>, August 2024.
- [SU06] Vladimir Shpilrain and Alexander Ushakov. A new key exchange protocol based on the decomposition problem. In *Algebraic methods in cryptography*, volume 418 of *Contemp. Math.*, pages 161–167. Amer. Math. Soc., Providence, RI, 2006.
- [ŠUA23] Zoran Šunić and Jone Uria-Albizuri. Portrait growth in contracting, regular branch groups. *J. Algebra Appl.*, 22(8):Paper No. 2350180, 18pp., 2023.
- [ŠV12] Zoran Šunić and Enric Ventura. The conjugacy problem in automaton groups is not solvable. *J. Algebra*, 364:148–154, 2012.
- [Tit72] J. Tits. Free subgroups in linear groups. *J. Algebra*, 20:250–270, 1972.