

Reinforcement Learning for an Efficient and Effective Malware Investigation during Cyber Incident Response

Dipo Dunsin *, Mohamed Chahine Ghanem, Karim Ouazzane, Vassil Vassilev,

Abstract—Our research focused on enhancing post-incident malware forensic investigation using reinforcement learning (RL). We reviewed existing literature to identify the limitations of RL, heuristics, and signature-based methods, emphasizing RL’s potential to overcome these limitations. We proposed an advanced RL-based post-incident malware forensics investigation model and framework to expedite post-incident forensics. We developed a robust malware workflow diagram and datasets, examining both uninfected and infected memory dumps for anomalies and artefacts. We created a unified Markov decision-process (MDP) model to guide an RL agent through well-defined state and action spaces. We elaborated distinct MDP environments for each of the 13 malware variants. We then implement our RL Post- Incident Malware Investigation Model based on structured MDP within the proposed framework. To identify malware artefacts, the RL agent acquires and examines forensics evidence files, iteratively improving its capabilities using Q-table and temporal difference learning. The Q-learning algorithm significantly improved the agent’s ability to identify malware. An epsilon-greedy exploration strategy and Q-learning updates enabled efficient learning and decision-making. Our experimental testing revealed that optimal learning rates depend on the MDP environment’s complexity, with simpler environments benefiting from higher rates for quicker convergence and complex ones requiring lower rates for stability. Our model’s performance in identifying and classifying malware reduced malware analysis time compared to human experts, demonstrating robustness and adaptability. The study highlighted the significance of hyper-parameter tuning and suggested adaptive strategies for complex environments. Our RL-based approach produced promising results and is validated as an alternative to traditional methods notably by offering continuous learning and adaptation to new and evolving malware threats which ultimately enhance the post-incident forensics investigations.

Index Terms—Cyber Incident, Digital Forensics, Artificial Intelligence, Reinforcement Learning, Markov Chain, MDP, DFIR, Malware, Incident Response.

I. INTRODUCTION

Malware, also known as malicious software, is a type of software that infiltrates and compromises data and information,

performing harmful and unauthorised functions. Its presence can lead to severe consequences, such as data theft, information destruction, extortion, and the crippling of organisational systems. In today’s digital landscape, investigating malware has become an urgent and paramount concern due to its potential for significant damage and loss. Recent studies reveal a startling reality: malicious software is proliferating at an alarming rate, with some strains employing deceptive tactics to evade cyber forensics investigations. According to Quertier et al., [1], AV-TEST estimates the daily discovery of approximately 450,000 new malware instances, 93 per cent of which are Windows-based malicious files, primarily in the form of portable executable (PE) files. This underscores the critical need for swift malware investigations when an attack occurs to prevent widespread damage and mitigate the risk of malware evolving into more sophisticated and destructive forms. Quertier et al., [1] also describe various malware investigation approaches, demonstrate the use of machine learning in malware analysis, and highlight how reinforcement learning improves malware models’ performance and accuracy.

The heuristic-based malware technique is a widely employed approach that analyses various system files, categorising them as normal, unusual, or potentially harmful. Aslan and Samet [2], emphasise that while signature-based methods struggle with new malware, a combination of heuristic and signature-based approaches offers a reliable and expeditious means of identifying malicious software. In contrast, deep learning-based approaches exhibit remarkable capabilities in identifying both known and previously unseen malicious software, surpassing the performance of behaviour-based and cloud-based techniques. Malware analysis and classification heavily rely on machine learning algorithms trained to distinguish between malware and benign files. Machine learning-based approaches, according to Akhtar [3], face several challenges, including the frequent return of false positives and the ability of new malware with polymorphic traits to alter their file signatures and evade identification. To overcome these challenges, machine learning techniques train algorithms to better identify and classify various forms of malware based on patterns and features found in extensive databases. By equipping algorithms to identify and classify different types of malware, machine-learning approaches enhance the security of computer systems and networks [4].

While many malware instances exhibit distinct features and static structures that differentiate them from benign soft-

* Dipo Dunsin is the corresponding author.

Mr. D. Dunsin is with the Cyber Security Research Centre, London Metropolitan University, London, UK. email: d.dunsin@londonmet.ac.uk

Dr. M.C. Ghanem is with the Cyber Security Research Centre, London Metropolitan University and the Department of Computer Science, University of Liverpool, Liverpool, UK. email: m.ghanem@londonmet.ac.uk

Prof. K. Ouazzane is with the Cyber Security Research Centre, London Metropolitan University, London, UK. email: k.ouazzane@londonmet.ac.uk

Prof. V. Vassilev is with the Cyber Security Research Centre, London Metropolitan University, London, UK. email: v.vassilev@londonmet.ac.uk

ware, some possess characteristics that make them challenging to identify accurately [5]. Even with advances in machine learning, complex, evolving malware can evade these models and remain hidden, particularly when it is novel or highly adaptable. Reinforcement learning becomes a valuable tool in these scenarios, as it enables the creation of new malware samples capable of evading machine learning identification. These new samples retrain the malware models to identify more unknown threats [6]. Reinforcement learning distinguishes itself from conventional machine learning models by embracing uncertainty and extensive trial and error as opposed to predefined mappings [7]. This quality makes reinforcement learning particularly effective in situations where specific answers are elusive, such as in the analysis of new and unknown malware threats [8]. During the implementation of reinforcement learning algorithms, exploration plays a pivotal role. Through exploration, the model actively explores various features, expanding the breadth of knowledge about different malware types. Subsequently, exploitation comes into play, enhancing the model's performance by selecting the most beneficial attributes [9].

In reinforcement learning, the reward techniques set it apart from other machine learning approaches. Reinforcement learning provides the agent with either negative or positive evaluation feedback, which may not necessarily indicate the correct actions in the environment. Generally, we depict the agent as capable of choosing a specific set of features that, when applied, enhance the model's accuracy. The ever-changing environment, shaped by the agent's actions, facilitates the collection of relevant features for classification. According to Fang et al., [10], 'the accuracy of the classifier serves as a reward,' with the DQFSA architecture being a noteworthy example that employs reinforcement learning for feature selection. Reinforcement learning typically involves an agent that interacts with the malware analysis environment, introducing modifications to files to relate them to expected performance outcomes. Recent research, such as REINFORCE and Deep Q-Network (DQN), has harnessed reinforcement learning to enhance malware investigations by leveraging past knowledge, according to Quertier et al., [1]. This is particularly advantageous, as traditional machine learning models often lack the ability to incorporate background knowledge into their malware analysis. Reinforcement algorithms can reduce trial-and-error efforts and rely on past experiences to analyse and classify malware more efficiently using verified knowledge [7].

A. Research Aim

The goal of this research is to improve malware forensics investigations by leveraging reinforcement learning techniques. Specifically, the research aims to identify, analyse, and enhance malware forensics investigation models to enhance their accuracy in post-incident investigations. This, in turn, should expedite malware forensics investigations and mitigate the current '*miscarriage of justice*' within the UK justice system. In addition, the study concentrates on enhancing heuristic- and signature-based analysis techniques using reinforcement learning in the event of a post-incident forensic investigation.

The study aims to enhance and optimise malware forensics investigation by implementing a reinforcement learning model and effectively handling new and unknown types of malware. This, in turn, should ultimately improve overall cybersecurity measures in the aftermath of an incident.

B. Research Objectives

- *Investigate Reinforcement Learning Methodologies:* The primary objective is to investigate and develop reinforcement learning-based methodologies for automating a human forensics expert's routine task, specifically identifying malware artefacts following a security incident.
- *Introduce Reinforcement Learning Model for Malware Forensics:* Develop a sophisticated reinforcement learning model that can efficiently analyze malware. This model aims to: 1. Precisely identify and classify malware samples. 2. Adapt seamlessly to new malware types and their variants. 3. Enhance performance in post-incident scenarios. 4. Improve the overall effectiveness of post-incident malware forensics investigations.
- *Develop a Multi-Approaches Malware Forensics Framework:* Enhance current manual post-incident forensics analysis by leveraging AI techniques combined with heuristic and signature-based approaches to introduce a comprehensive post-incident malware forensics investigations framework.
- *Produce an Empirical Evaluation of the Proposed Model and Framework:* Test the developed MDP model and Framework using real-world data to validate their effectiveness in identifying malware compared to traditional methods.

C. Related Work

In our research, we use Q-learning in a set action and state space to train RL agents on how to investigate for malware in post-incident malware forensics. We improve the agent's performance by continuously providing it with feedback on its performance in the MDP environment. Similarly, Binxiang

[11] leveraged deep reinforcement learning to overcome the limitations of traditional signature-based methods, using Q-learning to adapt to evolving malware threats, demonstrating the superiority of RL over static approaches. In a similar approach, Fang et al., [10] extended this by proposing the DQEAF model, which uses deep Q-networks to evade anti-malware engines, emphasising the creation of evasive malware that bypasses traditional malware analysis methods. The Markov Decision Process (MDP) model helped us organise our research even more. It helped us compile a list of the states and actions that make up the proposed reinforcement learning post-incident malware investigation framework. For instance, it assisted us in acquiring live memory images and identifying the operating systems in use. In a related study, Quertier et al., [1], used the DQN and REINFORCE algorithms in an MDP framework to test machine learning-based malware analysis engines and find actions that could turn malware into undetected files. In defining our action and state space, we identified 67 unique states and

up to 10 actions within our RL model, facilitating a thorough malware forensics investigation. This detailed mapping is similar to the work of Ebrahimi et al., [12], who used action and state spaces in their AMG- VAC model to improve static malware analysis in black-box attack scenarios. Their study showed the pros and cons of using separate action spaces for various malware identification needs.

Additionally, we integrated various machine learning techniques, including static and behavioural analysis, to enhance our proposed framework's robustness. This integration was adapted from Wu et al. work [6], who emphasised the enhancement of malware analysis models using reinforcement learning by incorporating past knowledge into RL algorithms to improve malware identification and classification. In parallel, Piplai et al., [7] also explored the use of knowledge graphs to inform RL algorithms for malware identification, highlighting the benefits of incorporating historical data into machine learning processes. In addition, we evaluated the performance of the RL model in our research methodology based on its ability to reduce the time required for post-incident malware forensic investigations and its accuracy in identifying malware. We measure this by conducting extensive experimental testing in simulated real-world scenarios. Similarly, in the broader literature, performance metrics often include the accuracy of malware identification and the time efficiency of the forensic process. For example, a study by Raff et al., [13] evaluates their RL-based malware identification system on similar parameters, emphasising the efficiency of the RL agent in real-time scenarios. While the related work provides a solid foundation in malware analysis and MDP modelling, our research methodology builds upon this foundation by offering practical, detailed methodologies and demonstrating their application in real-world scenarios. This progression from theoretical concepts to practical implementation marks a significant contribution to the field of cybersecurity and post-incident malware forensics investigation.

D. Research Contribution

This research aims to answer the following research question:

- **RQ1:** How effective are current reinforcement learning models in distinguishing between benign and malicious software, and what improvements are necessary to enhance their accuracy? This question seeks to evaluate the performance of existing reinforcement learning-based malware analysis models and identify areas where these models may require refinements or completely new approaches to improve their effectiveness.
- **RQ2:** What role can reinforcement learning play in enhancing malware analysis capabilities against known and novel malware threats during post-incident malware forensics investigations? This question explores the potential of using reinforcement learning to identify malware patterns that traditional malware analysis tools

struggle to investigate. This could help find and stop a wider range of threats.

- **RQ3:** Can post-incident malware forensics investigations effectively integrate reinforcement learning and adapt to evolving malware signatures? The question seeks to explore whether reinforcement learning can constantly improve and update RL model algorithms, thereby improving the model's ability to handle new types of malware during post-forensics investigations.
- **RQ4:** How can hybrid models combining heuristic and reinforcement learning approaches improve the reliability and speed of post-incident malware forensics investigation? This question seeks to determine the feasibility and effectiveness of blending traditional heuristic-based methods with reinforcement learning techniques to create a robust framework for analysing post-incident malware more efficiently and with greater accuracy.

Our research significantly enhances post-incident malware forensics investigations through reinforcement learning, offering a robust framework for combating complex cyber threats. Our contributions include:

- **RC1:** We created a comprehensive malware analysis workflow diagram that incorporates a variety of malware analysis techniques. We designed the malware workflow diagram to examine and analyse malware from live memory dumps using methods like static analysis, signature-based analysis, behavioural analysis, and machine learning algorithms. This malware workflow diagram increases adaptability and robustness in malware analysis, improves overall information security, and aids in forensic investigations post-incident.
- **RC2:** We implemented a unified MDP model that combines several MDP subsections into one holistic overview. This model includes states, actions, rewards, and transition probabilities, providing a structured approach for the RL agent to identify and isolate suspicious files. The unified MDP model offers a systematic method for malware analysis, enabling the RL agent to perform optimally by understanding the environment through a series of well-defined steps.
- **RC3:** We successfully developed sophisticated reinforcement learning Framework. This Framework outperform any existing automation or human expert in investigating malware infection requiring little time and resources and resulting in higher accuracy.
- **RC4:** We implemented an new approach using AWK module and Volatility 3 to extract specific data from memory dumps, which we then analyzed to identify active processes and potential malware. This approach improves malware investigations by providing detailed insights into the memory dump and facilitating the identification of anomalies and compromise indicators.
- **RC5:** We Elaborated an important malware forensics analysis dataset made out real-world malware scenarios.

TABLE I: Summary of Related Works.

Reference	Contribution	Benefits	Drawbacks
Ebrahimi et al., [12]	Proposed an AMG detector against black-box attacks	RL-based models improve malware analysis against evasion tactics.	Discrete actions may not suit all detectors, limiting universality.
Birman et al., [20]	Introduces real-time malware analysis using deep RL.	Enhances computer security with effective malware analysis.	Requires a large amount of training data.
Fang et al., [10]	Develops DQFSA for automated malware classification with deep Q-learning.	DQFSA streamlines feature selection using RL, saving time and effort.	Lacks details on restrictions imposed on the AI agent in the action space.
Anderson et al., [17]	Uses RL innovatively to evade PE-based malware models.	Strengthens ML-based malware analysis against adversarial threats.	Focuses on static PE models, ignoring dynamic and behavioural analysis.
Wu et al., [6]	Trains RL agents for optimal malware investigation models.	Improves the accuracy of ML-based malware investigations.	The need for extensive training data may hinder practical use.
Song et al., [16]	Proposes Mab-Malware, an RL framework for evading static classifiers.	Aids in examining evasive malware samples.	Potential misuse by malicious actors complicates analysis.
Rakhsha et al., [28]	Presents a practical environment poisoning algorithm for RL.	Helps develop better defenses against poisoning attacks.	Does not thoroughly address all aspects of poisoning attacks.

This comprehensive dataset enabled us a comprehensive evaluation not only proves the effectiveness of the models but also ensures their reliability and robustness in practical applications as well as being available for future research use.

E. Paper Outline

We organise this research paper as follows: The abstract summarises the study’s primary focus on leveraging RL to expedite and improve post-incident forensic processes. As mentioned in **Section I**, the introduction sets the stage by emphasising the critical need for rapid and efficient malware investigations in light of the increasing prevalence of cyber threats. Following this, the literature review in **Section II** presents a thorough examination of existing malware analysis methods, underscoring the limitations of traditional approaches and highlighting the promise of RL. Furthermore, **Section III** and **Section IV** detail the research methodology development and implementation of the RL-based model, describing the design of the Markov decision-process (MDP) environments, the integration of reinforcement learning techniques, and the testing and evaluation of the RL agent in **Section V**. In addition, the results and discussion **Section VI** illustrate and describe the experimental findings, demonstrating the RL model’s superior performance in terms of speed and accuracy compared to traditional methods and human forensics experts capabilities.

Moreover, the conclusion **Section VII** encapsulates the key findings, reiterating the study’s significant contributions to cybersecurity and malware forensics. It emphasises the potential of RL to revolutionise post-incident investigations, providing faster and more accurate results. Additionally, the research offers a comparative analysis, highlighting the advantages of RL over heuristic and signature-based methods. Notably, the hybrid approach integrating heuristic and RL methods shows promising results. Finally, the paper suggests some artificial intelligence techniques for future research, such as exploring

advanced RL techniques and refining hybrid models, while emphasising the need for continuous learning and adaptation in RL models. The comprehensive references section supports the study, citing relevant literature on RL, malware analysis, and cybersecurity, thus providing a solid foundation for the research.

II. LITERATURE REVIEW AND BACKGROUND

A. Reinforcement Learning for Malware Analysis

Quertier et al., [1] research highlights the challenges of machine learning classifiers in identifying potential malware, especially when there is limited insight into the malware output. The study suggests using reinforcement learning with REINFORCE and DQN algorithms to test the effectiveness of EMBER and MalConv machine learning analysis on commercial antivirus solutions. The study found that REINFORCE has a higher evasion rate and better performance than DQN, especially when tested against a commercial antivirus. However, a more comprehensive approach could have included training these models on a broader array of diverse models.

B. Deep RL for Malware Analysis

In 2019, Binxiang, Gang, and Ruoying [11], introduced a deep reinforcement learning-based technique for malware identification, aiming to address the vulnerabilities of traditional signature-based and machine learning-based approaches. The research demonstrated that deep reinforcement learning outperformed traditional methods based on static signatures and demonstrated the ability to quickly adapt to the ever-changing landscape of malware. However, the study had limitations, including a lack of comprehensive details about the experimental design, datasets used, and evaluation metrics. Expanding the training dataset and incorporating domain-specific knowledge could improve malware analysis. Notably, expanding the training dataset’s size and diversity, as suggested by Szegedy et al., [14], could significantly enhance the effectiveness of the malware investigation. Researchers like Silver

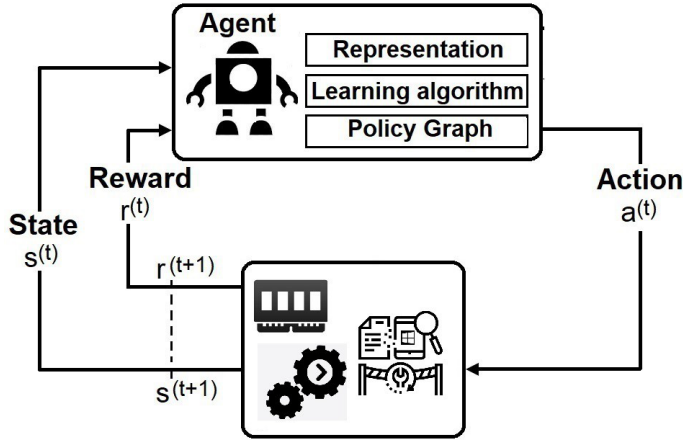

Fig. 1: RL Framework Environment

et al., [15], emphasise the value of incorporating domain-specific knowledge into deep reinforcement learning systems. While the authors assert their method's superiority, more comprehensive comparative analyses and statistical evidence could have provided more support for their claims.

C. RL-Based Attacks on Static Malware Detectors

Ebrahimi et al., [12] research aims to improve the effectiveness of static malware detectors in countering black-box cyberattacks. They propose using reinforcement learning (RL) to optimise the decision-making process of static malware detectors in the presence of black-box attacks. They create the Variational Actor-Critic for Discrete Adversarial Malware Generation (AMG-VAC) using discrete operations and an approximate sampling operator. They use RL to optimise the decision-making process, adjusting the neural network's weights based on the reward signal. In terms of accuracy, the RL-based AMG detector outperforms the original detector, particularly in the presence of black-box attacks. In addition, their results show that the RL-based AMG detector is much more accurate than the original detector when it comes to black-box attacks. However, RL in discrete action spaces may not align with all types of malware detectors, and its effectiveness depends on factors like the training dataset quality and the neural network's architecture.

D. Malware Analysis Using Intelligent Feature Selection

Fang et al., [10] developed a specialised architectural solution called DQFSA to address the shortcomings of traditional malware classification methods. The architecture uses deep Q-learning to identify crucial features, reducing human intervention and allowing data selection and analysis across various cases and data volumes. The methodology incorporates multi-view features, focusing on high classification accuracy during the validation phase. The key difference lies in exposing an AI agent to sample features with minimal human intervention. Experiments validated the DQFSA architecture by comparing its performance against various classifiers and related works.

However, the DQFSA framework imposes restrictions on the AI agent within the action space that remains unexplored.

E. Modern Incident Response Enhanced by AI

Dunsin et al., [18] present a study on the application of artificial intelligence (AI) and machine learning (ML) in digital forensics, focusing on enhancing malware investigation through innovative methodologies. The paper highlights the integration of AI and ML techniques to improve investigative precision and efficacy in digital forensics, leveraging advanced computational models to automate the investigation and analysis of cyber threats. Another focus is memory forensics, which focuses on machine learning algorithms to analyse memory dumps and malware, enhancing the reliability of forensic investigations by extracting and analysing multiple artefacts.

The study highlights the advantages of AI and ML in digital forensics, such as data mining techniques, reinforcement learning, and Markov decision process (MDP) for automated malware analysis. However, the study acknowledges challenges such as data validity, appropriate tools for memory dump retrieval, and adhering to ethical and legal standards. The study also proposes reinforcement learning, modelled as a Markov decision process (MDP), as a method for investigating malware in digital forensics. The MDP framework allows for systematic evaluation of different states and actions, facilitating the development of effective RL models for malware investigation, as illustrated in **Figure 1**.

F. ML and Knowledge Based System for Malware Analysis

Piplai et al., [7]) propose a framework that uses reinforcement learning and open-source knowledge to enhance malware analysis. The framework consists of two components: reinforcement learning for malware analysis and knowledge from open sources detailing past cyberattacks. The research experiments create 99 distinct processes during data collection, enabling the model to identify new malware. In similar research, Gallant [19] conducted a malware investigation experiment in which the researchers trained and employed multiple machine learning algorithms, including Perceptrons, and rigorously tested their performance. However, Piplai et al., [7] leave unspecified aspects, such as determining which prior knowledge is relevant for new malware analysis and whether prior knowledge might introduce biases from previous cases. Despite these concerns, the framework's incorporation of prior knowledge remains valuable, guiding new models with increased efficiency and accuracy.

G. RL for Malware Investigations

Reinforcement learning in malware forensics investigations involves an agent that seeks to optimise cumulative rewards by effectively managing the trade-off between exploration and exploitation. Our research's primary focus is on using reinforcement learning techniques to automate the process of conducting post-incident malware forensics investigations following a security incident. The agent performs actions within the environment, leading to changes in its state. The

objective is to gradually enhance the agent’s performance, enabling it to precisely identify portable executables as either malicious or benign. In the context of the proposed post-incident malware forensics investigations, the reinforcement learning agent begins at *state zero (0)*, takes guided actions, and receives rewards or penalties. With each action and reward, it enhances its strategy through iterative learning until it attains an optimal approach.

TABLE II: Malware Names Against the Operating Systems

Malware Variant	Target Windows OS
1 - WannaCry	Windows 7 Professional SP2.
2 - Cerber	Windows 7 All in One AIO (32/64-bit).
3 - DeriaLock	Windows 11 ISO 22H2 - 64bit.
4 - LuckyLcoker	Windows 8.1 Pro 6.3.9600 - 64bit
5 - Dharmia	Windows 8.1 Pro 6.3.9600 - 32bit.
6 - SporaRansomware	Windows 10 2022 - 32bit.
7 - GandCrab	Windows 10 2022 - 64bit.
8 - GoldenEye	Windows 10-64bit.
9 - Locky.AZ	WinDev2303Eval.
10 - InfinityCrypt	MSEdge – Windows 10.
11 - Win32.BlackWorm	Windows 7 Professional SP1 v6.1.7601.
12 - PowerLoader	Windows 7 Starter SP1 v6.1.7601.
13 - W32.MyDoom.A	Windows 7 Ultimate SP1 v6.1.7601.

III. RESEARCH METHODOLOGY

A. Experimental Setup and Dataset Generation

To implement and validate our proposed reinforcement learning malware investigation framework, we took a systematic approach to creating a comprehensive malware dataset using the *London Metropolitan University Digital Forensics Laboratory*. First, we established thirteen virtual machines within an isolated network to ensure a secure and controlled environment for our experiments and the eduroam network. This setup was critical to preventing the spread of unintended malware and maintaining the integrity of our data collection process. Next, we uploaded 13 different ISO files, each representing various versions of the Windows operating system. This diverse selection of operating systems allowed us to test our framework across a broad spectrum of environments.

Next, we introduced a variety of malware to infect each of these operating systems. We specifically chose each malware type to represent different attack vectors and behaviours, providing a robust challenge for our investigation framework. For each *ISO* file installed on the virtual machine, we took an initial snapshot of the environment and saved the live memory dump. Following this, we infected the virtual machine with the chosen malware and took another snapshot. This process resulted in pairs of snapshots, one uninfected and one infected, for each operating system. This methodology yielded 13 *RAM files* from the uninfected environments and another 13 from the infected ones. To analyse these files, we used the Volatility framework, a powerful tool for memory forensics. We manually examined both the infected and uninfected RAM files, which, as a result, enabled us to identify significant changes and behaviours indicative of malware presence. To ensure replication and verification of our procedures, we diligently documented each stage of the analysis. This documentation was critical for maintaining the integrity of our research, as well as for future reference. Finally, based on our analysis of the 26 files, we created a detailed malware workflow

diagram. This diagram mapped out the typical processes and behaviours associated with the malware samples, providing a visual and analytical aid for understanding how different malware affects system memory. This workflow diagram is a crucial component of our proposed reinforcement learning post-incident malware forensics investigation framework, serving as a foundational element for training and validating our model. The visual diagram in *Figure 2* illustrates the steps we took to create the dataset, outlining each component, from setting up the virtual machine to creating the malware workflow diagram.

B. Malware Workflow Diagram Creation

The research methodology extends from our comprehensive experimental setup and dataset generation process to the development of a detailed malware analysis workflow diagram, as depicted in *Figure 3*. This diagram is integral to our reinforcement learning malware investigation framework, encompassing various malware analysis techniques, including data collection, examination, and analysis. Our dataset, comprising live memory dumps from 13 different versions of Windows operating systems—both infected and uninfected—provides the foundation for this workflow. We examined these dumps to detect anomalies, indicators of compromise, and potential malware artefacts by using the Volatility framework for memory forensics. The analysis phase incorporates a diverse array of techniques such as static analysis, signature-based analysis, behavioural analysis, and machine learning algorithms. The resulting malware workflow analysis diagram not only maps out the typical processes and behaviours associated with our chosen malware samples, but it also serves as a crucial tool for improving information security and post-incident malware forensic investigations. Our structured approach rigorously trains and validates our reinforcement learning model, strengthening our malware investigation capabilities.

C. Markov Decision Process (MDP) Formulation

In our problem, the Malware Investigation associated Markov Decision Process (MDP) provides a mathematical framework for modelling decision-making in situations where outcomes are partly random and partly under the control of a decision-maker. Our MDP is defined by the following components:

- **States (S):** In this case, $|S| = 67$ states.
- **Actions (A):** In this case, $|A| = 10$ actions.
- **Transition Function (T):** $T(s, a, s')$ represents the probability to transition from state s to state s' under action a .
- **Reward Function (R):** $R(s, a)$ represents the immediate reward received after performing action a in state s .
- **Discount Factor (γ):** A factor $\gamma \in [0, 1]$ that discounts future rewards.

Step 1: Define States and Actions

- Let $S = \{s_0, s_1, s_2, \dots, s_{66}\}$ where each s represents a unique state in the malware investigation model process.

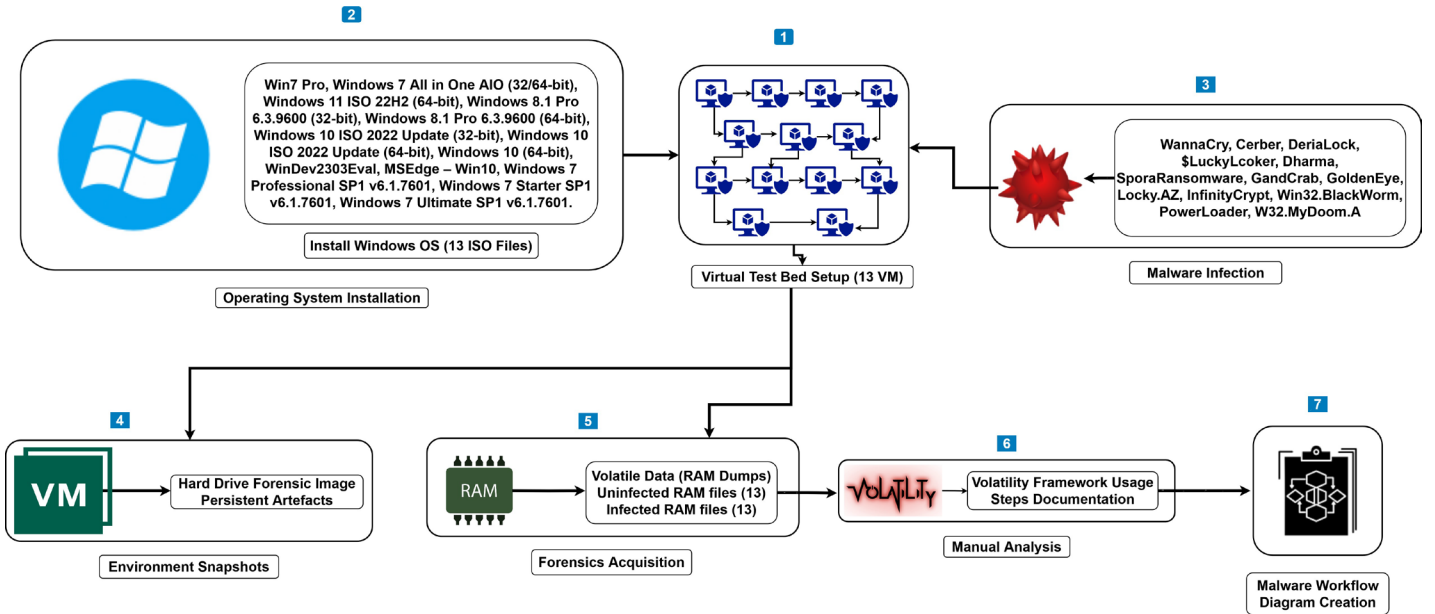

Fig. 2: Experimental Setup and Dataset Generation

- Let $A = \{a_0, a_1, a_2, \dots, a_9\}$ where each a represents a possible action.

Step 2: Define Transition Function $T(s, a, s')$

- The transition function $T(s, a, s')$ gives the probability of moving from state s to state s' when action a is taken.
- Example: If taking action a_2 in state s_5 has a 0.8 probability of transitioning to state s_{10} , then $T(s_5, a_2, s_{10}) = 0.8$.

Step 3: Define Reward Function $R(s, a)$

- The reward function $R(s, a)$ provides the immediate reward received after taking action a in state s .
- Example: If taking action a_3 in state s_8 gives a reward of 10, then $R(s_8, a_3) = 10$.

Step 4: Define Discount Factor γ

- Choose a discount factor γ (typically between 0.9 and 1) to weigh future rewards.

D. Leveraging Reinforcement Learning

In the context of our proposed Reinforcement Learning (RL), the agent learns the optimal policy π^* by interacting with the three proposed MDP environments. A common algorithm used is Q-learning, which updates the Q-values based on the Bellman equation.

1) *Value Function and Policy*: The value function for policy π is given by:

$$V^\pi(s) = \sum_a \pi(a | s) \sum_{s'} T(s, a, s') [R(s, a) + \gamma V^\pi(s')]$$

- $V^\pi(s)$: Expected cumulative reward starting from state s and following policy π .

- $\pi(a | s)$: Probability of taking action a given state s under policy π .

2) *Reinforcement Learning (RL) with Q-Learning*: subsection Leveraging Reinforcement Learning In the context of our proposed Reinforcement Learning (RL), the agent learns the optimal policy π^* by interacting with the three proposed MDP environments. A common algorithm used is Q-learning, which updates the Q-values based on the Bellman equation.

The Q-learning update rule is given by:

$$Q(s, a) \leftarrow Q(s, a) + \alpha \left(r + \gamma \max_{a'} Q(s', a') - Q(s, a) \right)$$

Where:

- α is the learning rate.
- r is the reward received after taking action a in state s .
- s' is the next state resulting from action a .
- $\max_{a'} Q(s, a)$ is the maximum estimated future reward from state s' .

Using the specifications as a result of the workflow diagram:

- We have 67 states and 10 actions.
 - The transition and reward functions would be defined based on the specific malware identification tasks.
- 3) *Q-Learning Update Rule*:

$$Q(s, a) \leftarrow Q(s, a) + \alpha \left(r + \gamma \max_{a'} Q(s', a') - Q(s, a) \right)$$

Step 1: Initialize Q-Table

- Initialize $Q(s, a)$ for all $s \in S$ and $a \in A$ to some arbitrary values (e.g., 0).

Step 2: Choose Learning Rate α and Discount Factor γ

- Example: $\alpha = 0.1$, $\gamma = 0.9$.

Step 3: Implement the Q-Learning Algorithm

- Initialize state s .
- Repeat:
 - Select an action a using an exploration-exploitation strategy (e.g., ϵ -greedy).
 - Take action a , observe reward r and next state s' .
 - Update Q-Table using the Q-learning update rule:

$$Q(s, a) \leftarrow Q(s, a) + \alpha \left(r + \gamma \max_a Q(s', a) - Q(s, a) \right)$$
 - Update state $s \leftarrow s'$.
- **Until convergence or a specified number of episodes.**

E. Setting the Parameters for MDPs

The Reinforcement Learning Post-Incident Malware Investigative Model uses the malware workflow diagram to define parameters for action and state spaces. The agent uses live memory dumps to analyse and identify malware artefacts, with **109** distinct actions within a defined environment. The state array aligns with the malware workflow diagram, encompassing **67** unique states. To achieve this alignment, we follow steps such as installing WinPmem, obtaining live memory images, understanding the operating system, extracting process information, listing DLLs, tracking open handles, collecting network data, figuring out registry hives, listing keys, duplicating processes into executable files, and sending them to Known Files Filters Servers.

F. The Motivation behind Implementing Q-Learning

The proposed Reinforcement Learning Post-Incident Malware Investigation Framework uses Q-learning, an off-policy, model-free algorithm. We use it because it employs a value-based approach to determine the optimal actions based on the current state. The algorithm learns the relative value of different states and actions through experiential knowledge without relying on explicit transition or reward functions. This approach is suited for the proposed RL model for analysing malware artefacts. In this context, ‘**Q**’ signifies quality, representing the action’s value in terms of optimising future rewards. On the other hand, model-based algorithms employ transition and reward functions to estimate the optimal policy and construct a model, whereas model-free algorithms acquire knowledge about action outcomes experientially, without explicit transition or reward functions. In our proposed implementation, we opt for the value-based approach, which entails training the value function in order for the agent to learn the relative value of different states and take actions accordingly. Conversely, policy-based methods directly train the policy to determine the appropriate action for a given state. On the other hand, in off-policy methods, the algorithm assesses and improves a policy that is different from the action execution policy. In contrast, on-policy algorithms evaluate and refine the same policy employed for action execution.

G. Q-Learning Terminologies

In the following sections, we will implement the proposed Reinforcement Learning Post-Incident Malware Investigation Model. The following terminologies are defined and explained in brief. An **Environment** is the space or world in which the agent operates and takes actions. An **Agent** is the entity that learns and makes decisions by interacting with the environment. **States** (s) signify the agent’s present location within the environment. An **Action** (a) is the set of all possible moves or decisions the agent can make in the environment. Every action the agent takes results in either a positive reward or a penalty. **Episodes** mark the end of a stage, indicating that the agent cannot perform further actions. This occurs when the agent either accomplishes its objective or faces failure.

For each state-action pair, the agent uses a **Q-Table** to manage or store **Q-values**. We use **Temporal Differences (TD)** to estimate the expected value by comparing the current state and action with the previous state and action. The **learning rate** is a parameter that determines how much new information overrides old information. A **policy** is a strategy or mapping from states to actions that defines an agent’s behaviours. The **Discount Factor** is a parameter that determines the importance of future rewards. The **Bellman Equation** is a fundamental equation in Q-Learning that expresses the relationship between the Q-value of a state-action pair and the Q-values of the subsequent state-action pairs. The **Epsilon-Greedy** Strategy is a method for balancing *exploration* and *exploitation*.

H. Q-Table and Q-Function

As previously mentioned, the *Q-table* is one of the key components that facilitate the agent’s decision-making. It guides the agent in selecting the most favourable action based on expected rewards within the provided environments. The *Q-learning* algorithm updates the values of a *Q-table*, which essentially functions as a structured repository encapsulating sets of actions and states. However, defining the state and action spaces is a crucial preliminary step in effectively setting up the *Q-table*, a task that the malware workflow diagram facilitates. Furthermore, the *Q-function* plays a central role, using the *Bellman equation* and considering the *state(s)* and *action (a)* as its input. This equation significantly streamlines the calculation of both state values and state-action values.

I. Subsections of the Markov Decision Process Model

The proposed subsection of the *Markov Decision Process (MDP)* represents a segment of the comprehensive and *unified MDP model*. Each subsection of the *Markov Decision Process (MDP) model* contains states, actions, rewards, and a transition probability function. These subsections are crucial components of the unified MDP that provide an agent with the capabilities of identifying and isolating suspicious portable executable files for further investigations. This approach sets a benchmark for processes such as recognising process identities, analysing process DLLs and handles, examining network artefacts, and checking for evidence of code injection.

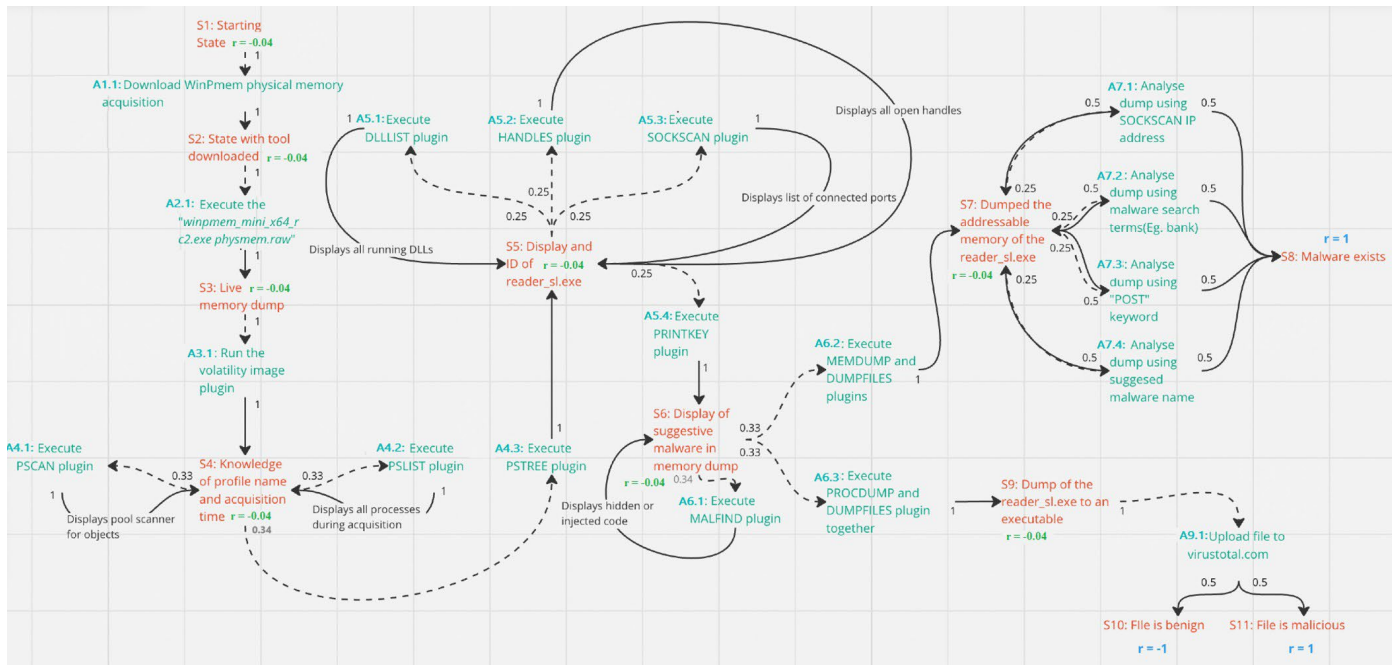

Fig. 3: Malware Workflow Diagram

- WinPmem Installation:** The WinPmem MDP subset represents the different states and actions involved in the installation process, including troubleshooting and resetting if errors or corruption occur during the installation. The ultimate goal is to reach *State 5*, indicating a successful installation of WinPmem. Each action is associated with a transition between states, either progressing through the installation, returning to a previous state for debugging, or starting over. The MDP helps model and understand the decision-making process involved in WinPmem installation.
- Acquiring Live Memory Image:** **Figure 4** outlines a decision-making process that involves actions, states, and transitions to achieve the goal of acquiring a live memory image, with the possibility of encountering errors and debugging them along the way. However, we structure it as a Markov decision process, where the actions taken in each state determine the state transitions. Additionally, the objective is to attain a desired state, specifically *State 10*, where successful live memory acquisition occurs.
- Identifying the Operating System:** In this sequence, the subset MDP illustrated in **Figure 5** entails the transition between states and the implementation of actions aimed at identifying the operating systems. States represent the system's status, and actions are taken to achieve the goal of identifying the operating system, including debugging steps to handle errors and crashes. In *state 15*, the agent successfully identifies the suggested profile name, date, and time information using the Volatility Image Plugin, indicating successful operating system identification.
- Identifying Process Information:** **Figure 6** illustrates the various states and actions available in MDP for retrieving

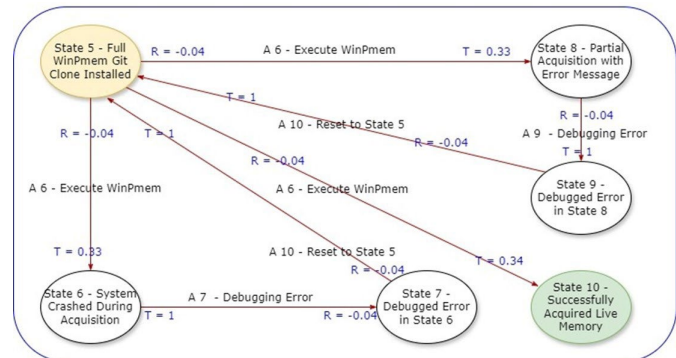

Fig. 4: Live Memory Acquisition

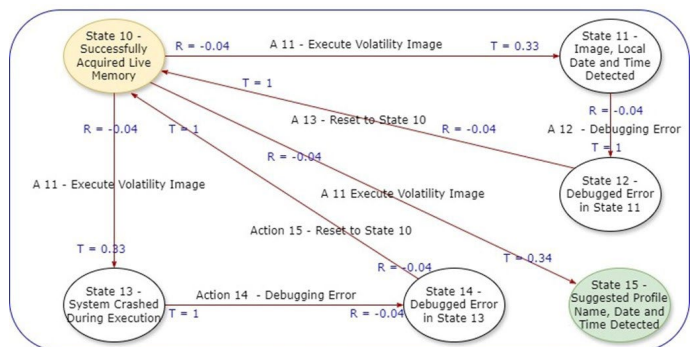

Fig. 5: Identifying Operating System

process information. This includes using different plugin functions, debugging to fix problems, and being able to choose from different ways to collect data about the process.

- AWK Module Features Extractions and Print List of**

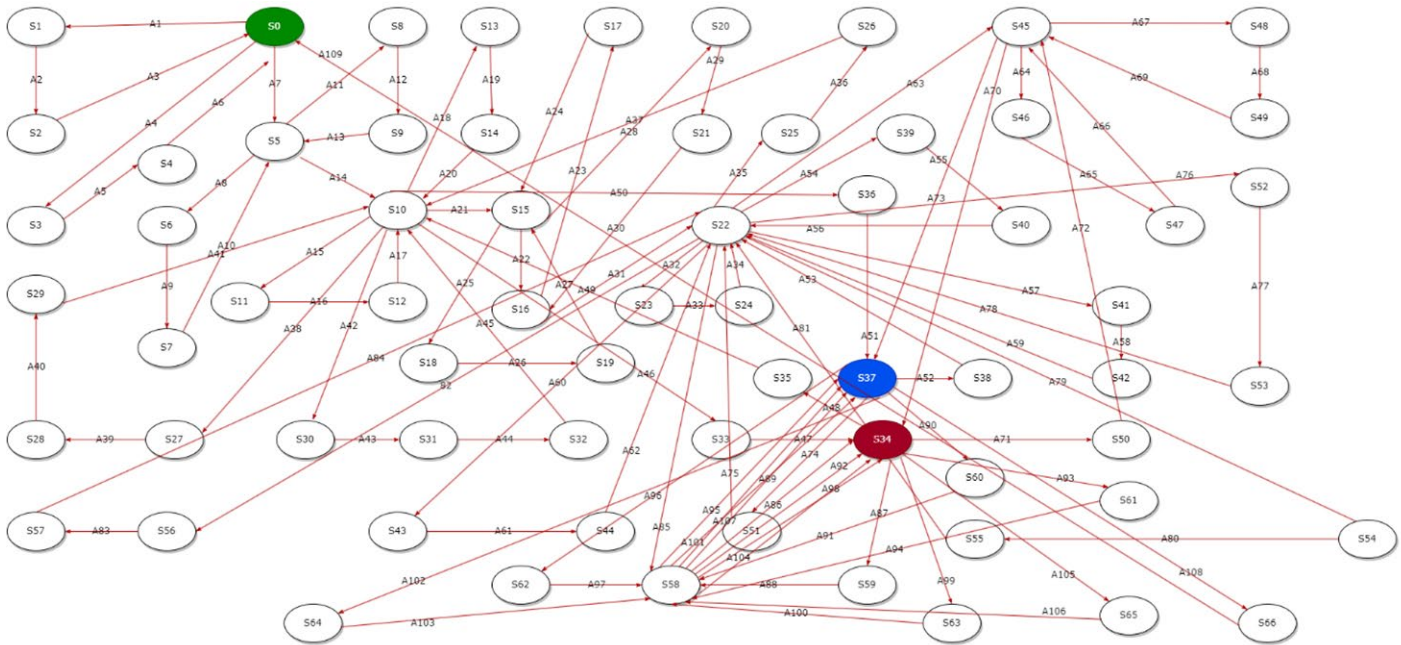

Fig. 8: Unified Markov Decision Process (MDP) Model

that estimates the expected cumulative reward from taking a particular action in a given state, following a particular policy. The agent observes the current state of the environment. The agent selects an action based on this state and its policies. The environment transitions to a new state and provides a reward to the agent. The agent updates its policy and value functions based on the reward received and the new state. This iterative process continues until the agent learns an optimal policy that maximises the cumulative reward over time.

M. Algorithm 1 - Implementation of the Q-Learning Algorithm

Algorithm 1 implements the Q-learning algorithm, a reinforcement learning technique, to train an agent to make optimal decisions in an environment. The code initially initialises a Q-table with zeros, symbolising the agent's understanding of the environment, where rows represent states and columns represent actions.

The code establishes key parameters such as the learning rate, discount factor, and exploration probability (*initially set to 0.9*), as well as decay schedules and structures for storing data (*storage, storage new, reward list*). The main loop runs for a specified number of episodes, resetting the environment and relevant variables at the start of each episode to obtain the initial state, reset the episodic reward, and initialise a step counter. A *'greedy policy'* selects actions within each episode: if the probability is high, it selects a random action (*exploration*); if not, it selects the action with the highest Q-value for the current state (*exploitation*). The environment executes the selected action, providing the next state, reward, and a done flag indicating the episode's end. The *Bellman equation* updates the Q-value, accounting for the immediate reward and the maximum future Q-value from the next state. The Q-table then stores the updated Q-value. Certain condi-

tions trigger the recording of specific Q-value updates. The state is then updated to the next state, and the current and new Q-values, along with the episode number and action taken, are appended to the storage list. A predefined schedule decays the exploration probability. We optionally check convergence by comparing the absolute difference between the new and current Q-values, and if the difference falls below a threshold but the values are not equal, we can terminate the loop early. We append the episodic reward, episode number, and step count to the reward list after each episode, thereby further decaying the episode. Finally, we return the Q-table, storage, reward list, and storage new, which summarise the learned policy and the data gathered during training. The process begins with the initialization phase, where three custom environments (*env new1, env new2, and env new3*) are defined using a defined *MDP function*. The algorithm then iterates over a list of names (*'name list'*), and for each name, it assigns the appropriate environment by configuring the Markov Decision Process (MDP) with specific transition probabilities and rewards.

N. Algorithm -2 Iterating Learning Rates Variation over MDP Environments

Algorithm 2 is an algorithm that *trains* and *stores* models using different *learning rates (LRs)* across multiple environments. The initialization phase initiates the process, defining various environments (envs) and creating an empty dictionary named *'final dict'* to store results.

Next, we set the training parameters, which include a list of learning rates ranging from *'0.001 to 0.9'*, and store the resulting Q-tables, intermediate storage, rewards, and additional storage collections. For each learning rate (*'lr'*) in the list of learning rates (*'lrs'*), the algorithm executes the *'new q learning'* algorithm. Finally, the algorithm stores the results

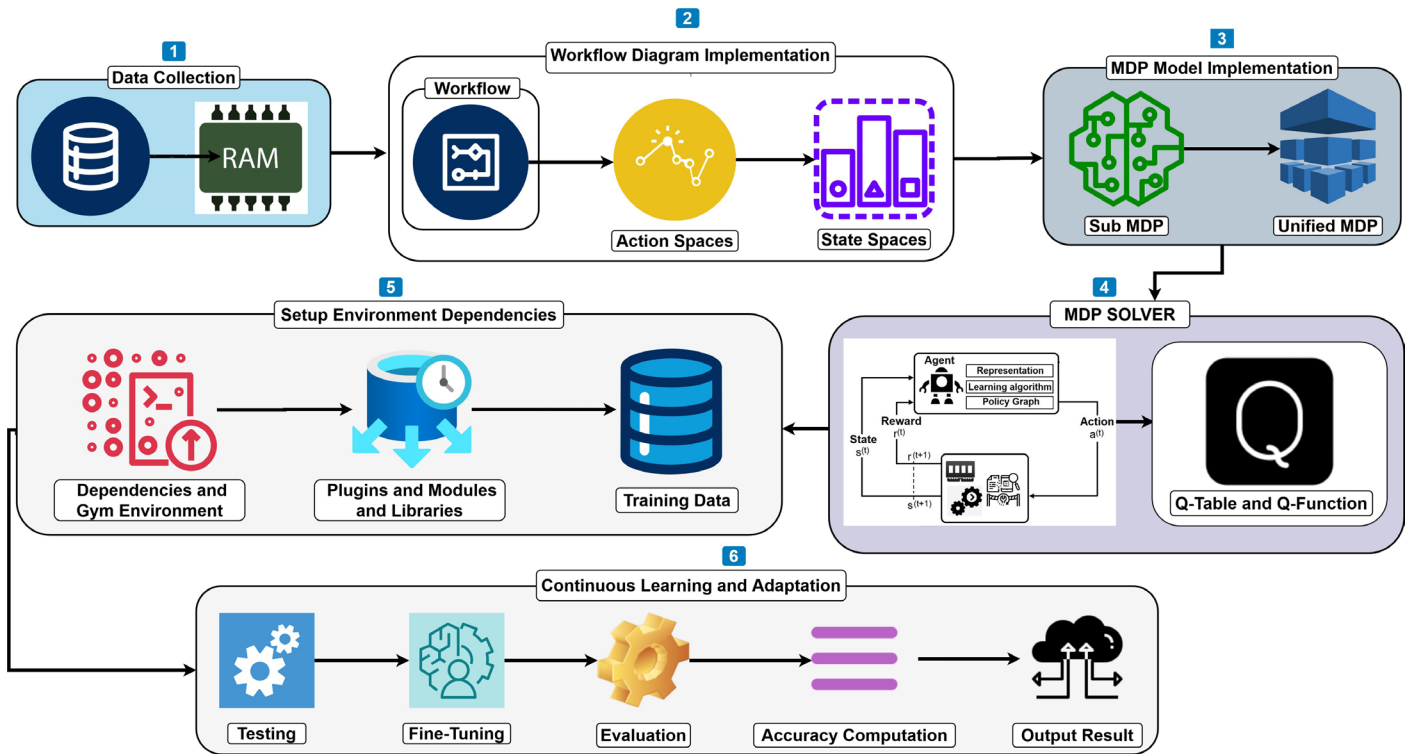

Fig. 9: The Proposed RL Post-Incident Malware Investigation Framework

by appending them to the *'final dict'*. This structured approach guarantees systematic model training and result storage for varying learning rates in different environments.

IV. MDP MODELS INTEGRATION AND IMPLEMENTATION

A. An Overview of Our Three Proposed MDP Environments

The *BlankEnvironment* models the proposed Markov Decision Process using the Malware Workflow Diagram, incorporating *states*, *actions*, *rewards*, *transition probabilities*, and *episode completion status*. It features a discrete action space with **10** actions and an observation space with **67** observations, assigning a standard step penalty of **-0.04** and a reward of **2** for identifying malware. The *BlankEnvironment_with_Rewards* gives a reward of **2** for all terminal states upon accurate malware identification and **4** for early-stage accurate identification, encouraging correct classifications. Conversely, the *BlankEnvironment_with_Time* imposes a harsher penalty of **-0.01** per step to incentivize efficient malware identification by discouraging the agent from taking unnecessary actions. Rewards serve as hyperparameters in both environments, refined for optimal agent performance.

B. Implementing MDP Environments Key Python Libraries

We begin by creating the *'Environment'* dependencies, importing essential libraries like *NumPy*, *Random*, *Time*, and *Gym* modules. We use *NumPy* for numerical computations, *Random* for generating random numbers, and *Time* for measuring code execution time. These measurements help optimise performance and compare our RL-based post-incident

malware investigation model with human experts. The *Gym* library, commonly used in reinforcement learning, defines environments, agents, and evaluates their performance, with its *'spaces'* module representing possible observations and actions in an RL environment.

C. Initialising the State and Action Variables

We assign values to two variables: *'noS = 67'* assigns the value **'67'** to the variable *'noS'*, implying that *'noS'* represents the *'number of states'*, with a value of **67**. The variable *'noA = 10'* assigns the value **'10'** to *'noA'*, signifying the *'number of actions'*, with a value of **10**. Q-Learning will continue to use these variables to define the dimensions of data structures.

D. Implementation of the BlankEnvironment

As shown in *Figure 10*, we define a new class named *'BlankEnvironment'*, which inherits from *'gym.Env'*, indicating its intended use as a gym environment. For the *BlankEnvironment* class, the constructor method initialises the class instance. The next variable defines the environment's action space and observation space. The action space is discrete, with **10** possible actions, whereas the observation space is discrete, with **67** possible observations. The next variable, *'self.state = 0'*, sets the initial state of the environment to **'0'**. We initialize *'self.P = dict()'* as an empty dictionary to store transition probabilities in the subsequent code block.

E. Defining Reset and Step Function

The *'def reset(self)'* function resets the environment to an initial state, returning the initial observation with *'self.state*

Algorithm 1 *Q-Learning Implementation*

```

1: Initialization:
  · Initialize Q-table with zeros. (defines the state of the agent)
  · Set parameters: learning rate ( $\alpha$ ), discount factor ( $\gamma$ ), exploration probability ( $\epsilon = 0.9$ ), decay schedule.
  · Initialize storage structures: storage, storage_new, reward_list.
2: for episode = 0, 1, ..., episodes do
3: Reset environment and variables:
  · Reset environment to obtain initial state.
  · Initialize episodic reward and step counter.
  · Store current epsilon value.
4: while not done do
5: Select action using  $\epsilon$ -greedy policy:
  · if  $\epsilon < \text{rand}()$  then
  · action  $\sim$  Uniform(noA)
  · else
  · action =  $\max_a Q(\text{state}, a)$ 
6: Execute action:
  · Perform the action in the environment and observe the next state, reward, and done flag.
  · Update episodic reward.
  · Increment steps counter.
7: Update Q-value using Bellman equation
8: Compute the maximum future Q-value for the next state.
9: Calculate the new Q-value
10: Update the Q-table with the new Q-value.
11: Store Q-value updates if specific conditions (e.g., state, action) are met.
12: Update state: Set the current state to the next state.
13: Append the (current_q, new_q, episode, action) to the storage list.
14: Decay  $\epsilon$ : Reduce epsilon based on the decay schedule.
15: Check convergence: if  $|\text{new\_q} - \text{current\_q}| < \text{threshold}$  and  $\text{new\_q} \neq \text{current\_q}$  then
16: Break the loop
17: Append (episodic_reward, episode, steps) to reward_list.
18: Update  $\epsilon$ :
  ·  $\epsilon \leftarrow \epsilon - (\epsilon_{\text{decay\_value}} \times 0.5)$ 
19: Return results:
  · Return Q-table, storage, reward_list, and storage_new.
20: end for

```

```

class BlankEnvironment(gym.Env):
    def __init__(self):
        # Define action space and observation space
        self.action_space = gym.spaces.Discrete(10)
        self.observation_space = gym.spaces.Discrete(67)

        #self.action_space = np

        self.state = 0

        self.P = dict()

```

Fig. 10: *Initialise and Implement the BlankEnvironment Class***Algorithm 2** *Iterating Learning Rates Variation over MDP Environments*

```

1: Initialization: Defining different envs and empty final dict
2: for name in name_list do
  1) Assigning the right env (MDP): Using diff transition probs and rewards to create the MDP
  2) Defining and resetting the training params:
    · Learning rates list
    · outputs, store and rewards dictionaries
  3) for lr in lrs do
    a) Performing the new_q_learning algorithm
    b) Storing everything by appending in the final_dict
  4) end for
3: end for

```

```

class BlankEnvironment_with_rewards(gym.Env):
    def __init__(self):
        # Define action space and observation space
        self.action_space = gym.spaces.Discrete(10)
        self.observation_space = gym.spaces.Discrete(67)

        #self.action_space = np

        self.state = 0

        self.P = dict()

    done = k[3]
    if done == True:
        reward = +4
        k = (k[0],k[1],reward,k[3])

```

Fig. 11: *Initialise and Implement the BlankEnvironment with Rewards Class*

= 0'. The 'def step(self, action)' method simulates a step in the **BlankEnvironment** based on the action, assigning a random number to 'temp' using 'np.random.rand(1)'. If the current state is between 0 and 66 and the action is between 0 and 5, the tuple 'k' is updated with the current state, 1, a reward of -0.04, and False.

F. Implementation of the BlankEnvironment with Rewards

The **BlankEnvironment_with_Rewards** is a completely different implementation compared to **BlankEnvironment**. As illustrated in **Figure 11**, in the **BlankEnvironment_with_Rewards**, actions leading to terminal states are assigned a reward of 2, in contrast to the -0.04 reward assigned in the **BlankEnvironment**. The reward function in **BlankEnvironment_with_Rewards** is modified when an episode ends, as indicated by the done flag. The done flag assigns the value of the fourth element to the variable done, which contains information about episode completion. The done flag checks if the done variable equals True, and the reward variable is set to a positive value of 4. This update considers the consequences of changing the reward when the episode ends.

G. Implementation of the BlankEnvironment with Time

In `BlankEnvironment_with_Time`, the agent incurs a more severe negative reward of -0.1 per step, compared to the standard penalty of -0.04 in the other two environments. This technique aims to incentivise the agent to efficiently identify malicious files by taking the most direct path, thereby discouraging any superfluous actions. When the agent extends episodes by taking additional steps, significant penalties are incurred. Notably, this incentive is considered a hyperparameter, as it is subject to continuous refinement. The expression `'done = k[3]'` assigns the fourth element of the tuple `'k'` to `'done'`, indicating whether the episode is complete. If `'done'` is `'True'`, a reward of $+4$ is assigned; otherwise, a penalty of -0.1 is given to the agent. The tuple `'new k'` is then created, keeping the original values of `'k'` but updating the reward value. We return this updated tuple for future interactions with the environment.

H. Iterating MDP Environments over Learning Rates

We implemented a Python code and iterated the three MDP environments over a range of learning rates ($0.001-0.9$). The `name_list = ['env_new1', 'env_new2', 'env_new3']` defines a list containing the names of the environments. We initialise an empty dictionary to store the final results and iterate over each environment using a `for` loop. We use the *Q-learning function* to convert the current learning rate to a float and store the results in dictionaries. We convert the output into a list and save it in the output dictionary. Finally, we group the collected data into a tuple and store it in the final dictionary, consolidating all results for further insight.

V. TESTING AND EVALUATION

A. Retrieving Data from final-dict

We implemented a Python code and defined several variables, including Q-tables for different learning rates (`q1`, `q2`, `q3`), changes in Q-values (`store1`, `store2`, `store3`), cumulative rewards (`reward1`, `reward2`, `reward3`), and Q-values for multiple states (`store_new1`, `store_new2`, `store_new3`) for environments `env_new1`, `env_new2`, and `env_new3`. It initializes these variables by retrieving data from `final_dict`, ensuring each set of variables corresponds to a specific environment. This consistent structure allows for efficient tracking and storage of Q-learning outcomes across multiple environments.

B. Comparing the Speed of Convergence

We implemented a Python code to visualise the speed of convergence across the three MDP environments, (`env_new1`, `env_new2`, and `env_new3`) representing `BlankEnvironment`, `BlankEnvironment_with_Rewards()`, and `BlankEnvironment_with_Time()`, respectively. Each dictionary maps learning rates to the number of episodes required for convergence. The code line `x = [float(key) for key in env_new1.keys()]` creates a list of floating-point learning rates from `env_new1`. The command

`plt.figure(figsize=(10, 6))` initialises a 10x6-inch plot, where we create scatter plots for each environment, using different colours (blue, red, and green) for distinction and adding lines to illustrate convergence trends. **Figure 12** shows that `BlankEnvironment_with_Rewards (env_new2)` has the smoothest and fastest convergence. In contrast, `BlankEnvironment_with_Time (env_new3)` converges slowly due to a higher negative reward function, necessitating larger learning rates and more computational time. `BlankEnvironment (env_new1)` also performs well, but it converges slower due to learning rate fluctuations. As a result, `BlankEnvironment_with_Rewards` is the best MDP environment, with a 0.4 learning rate.

C. Using Argmax to iterate over different learning rates and mdp environments

We implemented a Python code that initialises a list `lrs` with various learning rates and creates empty dictionaries `q1_dct` and `q1_dict` to store results for three different environments, `env1`, `env2`, and `env3`. The code then outputs a message indicating the processing of `env1`, then iterates over each learning rate in `lrs`, initializing lists within the dictionaries and retrieving the corresponding *Q-values* from `q1`. Within a nested loop running 67 times for different states, it prints the state index and the action index with the highest *Q-value* using `np.argmax(q_new[i])`, appending this information as a string to `q1_dct` and as an integer to `q1_dict`.

D. Using Softmax to iterate over different learning rates and mdp environments

We implemented a Python code that defines a `stable_softmax` function to calculate the softmax of an input array `x` in a numerically stable manner. It initialises a list of learning rates ($0.001-0.9$) and empty dictionaries for three environments: `env1`, `env2`, and `env3`. The code then iterates over the learning rates for each environment, processes *Q-values*, and converts them into probability distributions using the `stable_softmax` function. It then samples actions for 67 states, appending the action with the highest *Q-value* to the respective dictionary, and prints the *current environment* and *learning rate* at each step. Upon completion, it prints a `done` message, ensuring consistent performance across different environments and learning rates for further comparative analysis.

E. Evaluating rewards dynamics using learning rates and MDP environments

We implemented a Python code that examines reward changes in the three *MDP environments* (`env_new1`, `env_new2`, and `env_new3`), with learning rates ranging from 0.001 to 0.9 . To create interactive plots, it imports the `plotly.graph_objects` module as `go`. The code extracts cumulative rewards, episode numbers, steps per episode, and average rewards per step from episodes 3 to 100 for each environment. We create a new figure object `fig` using Plotly

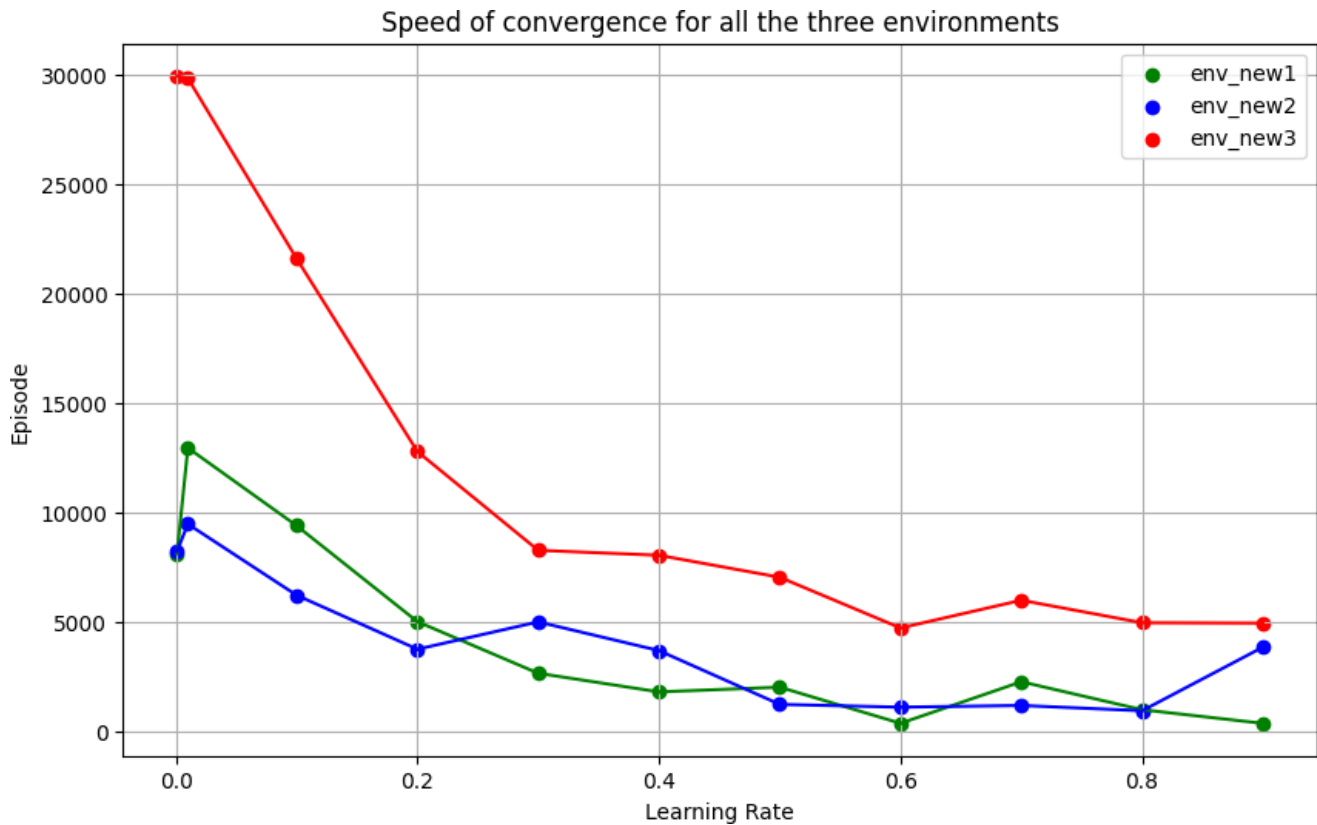

Fig. 12: The speed of convergence across the three MDP environments

and add three traces, each representing an environment with unique colours (green for `env_new1`, blue for `env_new2`, and red for `env_new3`). We update the plot layout with a centred title, axis labels, a legend title, and a hover mode that displays data for all traces at the same x-coordinate. To render and display the interactive plot, we call the `fig.show()` function, which compares the *average rewards per episode* for the three environments at different learning rates. However, the graph for *learning rate 0.4* is displayed in *Figure 13*.

F. Command Definitions for State-Based Actions

We imported the `Subprocess` module to allow the Python script to spawn new processes and manage their input/output/error pipes and return codes. We initialise and populate an empty dictionary, `my_dict`, with *key-value* pairs, each representing a *state* and each value a list of *commands* for that state. For example, state 0 includes a command to clone a GitHub repository, while state 10 has commands for Windows system information and the registry. States 15 to 45 have various commands, some including special characters and options like `-pid` and `-o`.

G. Implementing Command Logic in Python

We implemented a Python function `create_command` that takes three arguments: `command_dict`, `state`, and `action`. A dictionary (`command_dict`) is used to create a command based on the given *state* and *action*. The function

initialises a variable `pid` with the value 340 and uses the process ID, `pid`, in the command generation logic. The `if state == 1` block checks if the state parameter is equal to 1. If so, the code executes the next block. If the action parameter is greater than or equal to the length of the list of commands associated with the current state in `command_dict`, it is invalid. If the action is out of bounds, the code assigns the string `action out of list size` to the command variable. If the action is within bounds, the code starts an `else` block where the actual command generation takes place. The function also checks if the state variable is not in the dictionary, assigns the string `transitional state`, and checks if the action variable is greater than the list length.

H. Defining the 'commands timings' dictionary

We set up a nested dictionary called `commands_timings` to organise the different commands that were run on the Google Collaborative Environment for WannaCry, Cerber, and Cridex malware analysis families, along with the times at which they were run (shown by variables like `ta`, `tb`, etc.). Each malware family includes specific forensic commands for analysing aspects of system memory dumps, such as process lists (`windows.pslist`), registry scans, module analysis, and network statistics. Our research relies on these commands and timings to compare the time required by a human forensics expert with the Proposed Reinforcement Learning Post-Incident Malware Investigation Framework.

Avrs vs Episodes for Different Environments using 0.4 learning rate

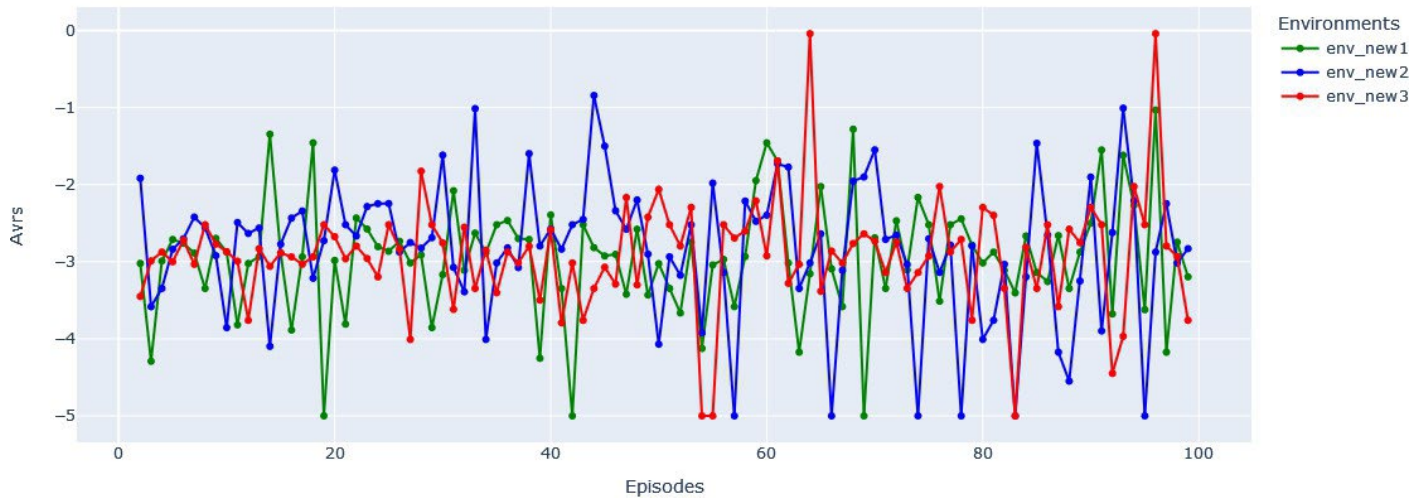

Fig. 13: Average Rewards vs Episodes for Different Environment using 0.4 learning rate

VI. RESULTS AND DISCUSSION

A. The Agent Decision-Making Processes

We implemented a Python script that initializes two lists, *ideal_list* and *pred_list*, containing integer values representing **actions** for specific **states** within our reinforcement learning MDP environment. The *ideal_list* assigns optimal actions for states 0 to 66, while the *pred_list* contains predicted actions for the same states. For example, *state 0* has an ideal action of 0 and a predicted action of 2. Each index in both lists corresponds to a specific state, facilitating the comparison of predicted actions against ideal outcomes to measure model performance across the three environments using varying learning rates.

B. Python Function to Evaluate Predictive Model Accuracy

To compare the accuracy of predicted actions against ideal actions, we implemented a Python function named *get_acc*. Initially, the function sets two variables, *true* and *false*, to zero to count correct and incorrect predictions, respectively. It iterates through the *ideal_list* and *pred_list* simultaneously using the *zip()* method, comparing each element; if they match, it increments *true*; otherwise, it increments *false*. After the iteration, the function computes the accuracy by dividing *true* by the total number of comparisons (*true* + *false*), formats the result to five decimal places, and prints the **accuracy**. This function is useful for evaluating prediction accuracy in reinforcement learning settings, and upon execution, it shows an accuracy of 94%.

C. Calling the *get_acc* function for accuracy computation

The implemented Python function named *get_acc* process multiple environments (*env1*, *env2*, and *env3*) represented

by dictionaries (*q1_dict*, *q2_dict*, and *q3_dict*). We defines *x* and *y* coordinates for three sets of data representing different environments: *env1*, *env2*, and *env3*. Each environment's data is stored in respective lists, such as *env1_x* and *env1_y*, *env2_x* and *env2_y*, and *env3_x* and *env3_y*. The code then creates three scatter plot traces using *go.Scatter*, specifying the data points, mode (lines and markers), names, and marker colors for each environment. A layout is defined for the plot, including a title, x-axis and y-axis labels, and hover mode configuration. A figure object is created by combining the traces and the layout, and the plot is displayed using *fig.show()*. This code effectively visualises the accuracy computation for different learning rates across *three* MDP environments, as seen in **Figure 14**. Consequently, it demonstrates that *env2*, with a **learning rate of 0.4**, is the best performing environment.

D. State transitions in our RL Post-Incident Malware Investigation Model

We implemented a Python function to simulate state transitions in the **BlankEnvironment_with_Rewards()** environment, using a **learning rate of 0.4** and driven by *actions* and *landing states*. Starting with the initial state *i* set to 0, the loop runs 20 iterations, printing the current state (*i*) and the associated action (*ideal_list_new[i]*). To determine the next state, we call the function *return_action_state* with *i*, *ideal_list_new[i]*, and *landing_list[i]*. If *i* reaches 66, the loop breaks. Finally, the code prints the final state (*i*) and its corresponding action (*ideal_list_new[i]*) after completing the loop or breaking out due to reaching state 66. This code structure allows for simulating and tracking state transitions based on predefined actions and conditions, providing insight into how the agent

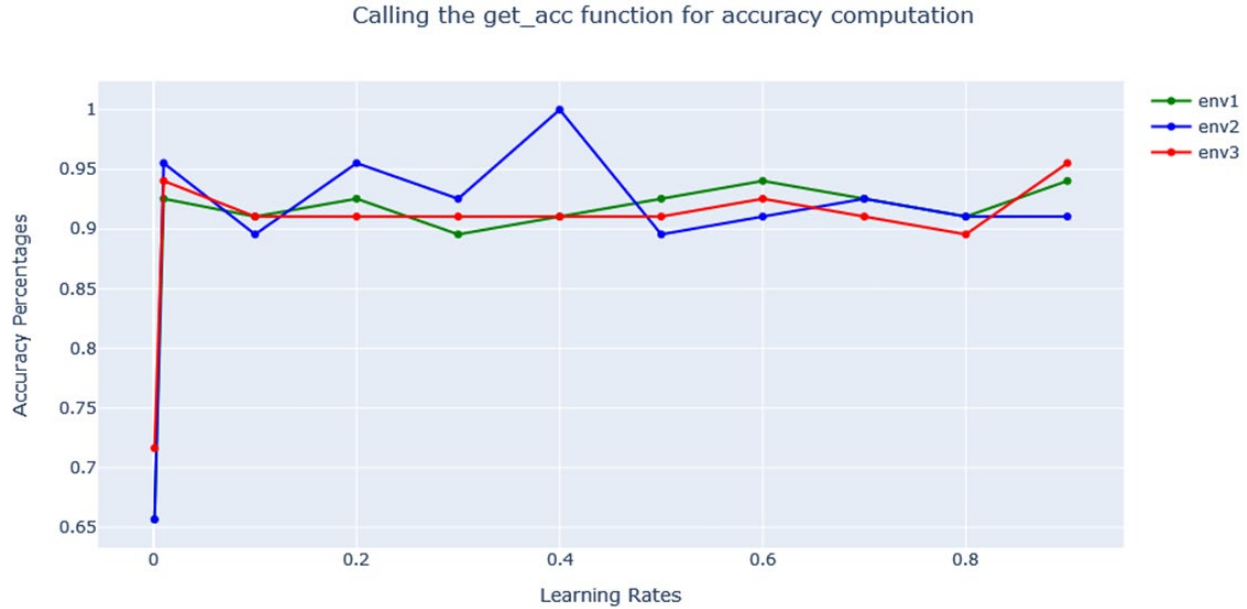

Fig. 14: Calling the `get_acc` function for accuracy computation

navigates through our proposed RL Post-Incident Malware Investigation Model.

E. Plotting the proposed Model command execution timings

As a result of keeping track of state changes using our proposed reinforcement learning post-incident malware investigation model, we obtain a trajectory based on actions and landing states, which control a series of state changes in the environment. We utilised the Google Collaborative Environment’s execution timings to plot the proposed model’s command execution timings. We created a new `command_timings_dict` to store keys and values related to states and action trajectories. We then defined new Python code to create a multi-plot figure using Plotly to analyze the execution time of different malware commands (WannaCry, Cerber, and Cridex). This code initializes a figure with three vertical subplots, each with a title and increased vertical spacing. We add line plots for WannaCry, Cerber, and Cridex to the first, second, and third subplots, respectively, ensuring each has distinct colors and markers. We update the figure’s layout to set its dimensions and center the title. The X-axis labels are customized for each subplot, and the y-axes are labeled with ‘Time (seconds)’. The resulting graph is displayed using `fig.show()`, as illustrated in **Figure 15** below.

F. Plotting Collab and PowerShell Environment Command Execution Timings

We created a Python script to visualise the execution timings of various commands executed on Google Collaborative environments and Fast Windows Machine. The script examined WannaCry, Cerber, and Cridex to design the malware work



Fig. 15: Malware Analysis Execution Time for Different Commands Executed Using the Agent (RL Model)

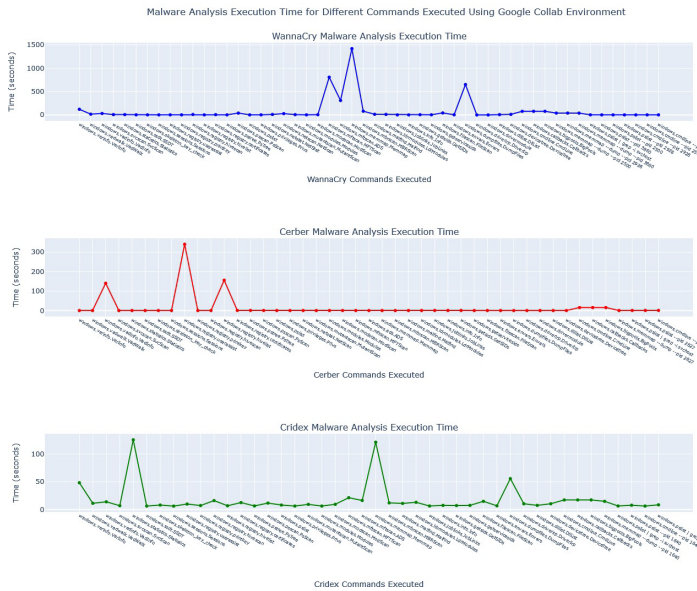

Fig. 16: Malware Analysis Execution Time for Different Commands Executed Using Google Collab Environment

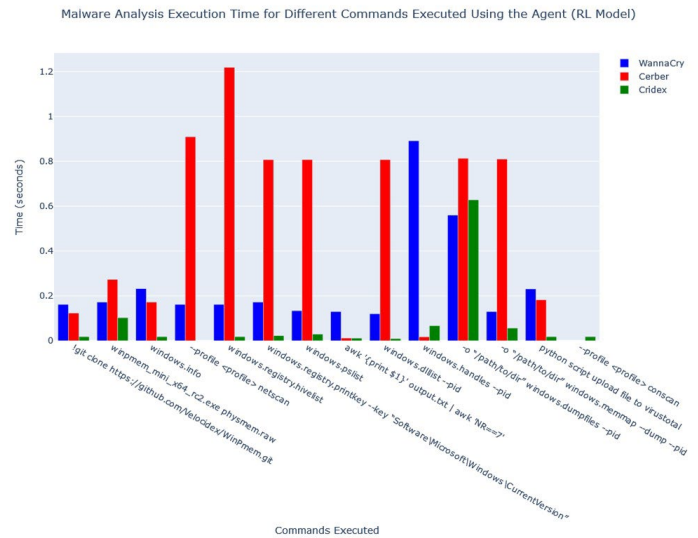

Fig. 18: Malware Analysis Execution Time for Different Commands Executed Using the Agent (RL Model)



Fig. 17: Malware Analysis Execution Time for Different Commands Executed using the PowerShell Environment

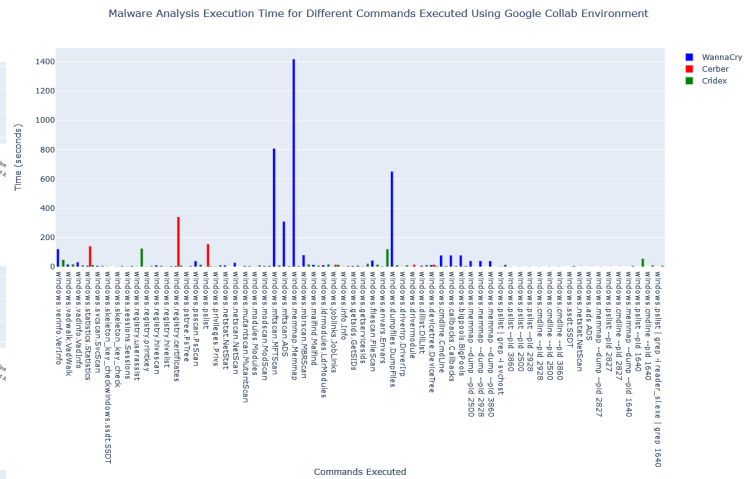

Fig. 19: Malware Analysis Execution Time for Different Commands Executed Using Google Collab Environment

flow diagram. The script used the Plotly library to create a multi-subplot figure, with scatter plots for each type. The graph provided a clear comparison of execution times for the three malware types. **Figure 16–17** display a graph that provides a clear visual comparison of the execution times for various commands executed on the three malware types using the Google Collab environments and Fast Windows Machine in the PowerShell.

G. Interactive Analysis of Malware Execution Times

We implemented a Python code using Plotly for interactive plotting, which allows us to visualise the execution times of

various commands performed by the agent when analysing different malware, specifically WannaCry, Cerber, and Cridex. We also used the same code to sample malware analysis execution times for commands executed in both the Google Collaborative Environment and a Fast Windows Machine in the PowerShell Environment. Consequently, we initialize a Plotly figure and add three separate bar plots for each malware type, with each bar representing the execution time of a specific command. Bars for WannaCry are blue, for Cerber are red, and for Cridex are green. The plot’s layout is customized to include a horizontally centered title, labels for the x-axis (*Commands Executed*) and y-axis (*Time (seconds)*), and grouped bars. Using `fig.show()`, we presented a visual comparison of command execution times across different malware types and environments, as illustrated in **Figure 18–20**.

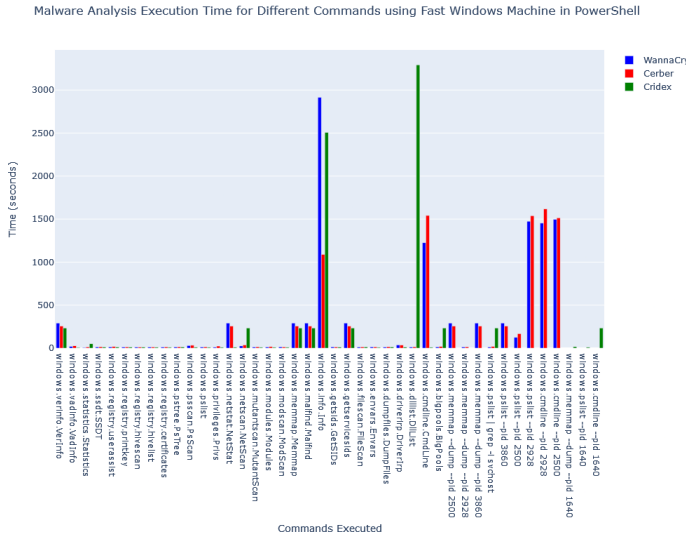

Fig. 20: Malware Analysis Execution Time for Different Commands Executed Using PowerShell Environment

H. Visualising execution times across multiple machines

We implemented a Python script that uses Plotly to display the total execution times for malware analysis across various machines. We iterate over the different machines and add up the execution times for each type of malware analysed (WannaCry, Cerber, and Cridex). We present the data as scatter plots with lines and markers, with each machine represented by a correspondingly designated trace. The layout contains a centred title and marked axes to help with data understanding. As a result, the chart provides a comparison view of the malware analysis execution timings of different machines, as shown in **Figure 21**.

I. Research Findings and Recommendations

This research explores the domain of post-incident malware forensics investigation using reinforcement learning (RL) techniques. The study highlights the growing significance of advanced reinforcement learning techniques in cybersecurity, specifically in their ability to adapt to the ever-changing nature of malware threats. The study focuses on finding malware artefacts after an incident and creates a structured workflow for implementing RL models that uses Q-learning. The goal is to automate the tasks of a human forensics investigator's process, increasing efficiency and speeding up investigation times. As a result, we develop the RL model, aligning its states and actions with the proposed malware workflow diagram. This structured approach ensures that the RL agent can explore and exploit data from various phases of the malware workflow diagram, learning how to identify and classify malware artefacts efficiently. The model's efficacy in navigating through different states, ranging from data collection to the analysis of potential threats, demonstrates its capability to adapt to new and emerging malware.

Despite the advanced capabilities of the proposed RL model, the study acknowledges certain inherent challenges. The

model's performance is contingent on the quality and diversity of the malware samples, which can significantly influence its accuracy and reliability. We recommend including a wider variety of malware samples in the training datasets to bolster the model's robustness. This diversity will help the model develop a more comprehensive understanding of different malware behaviours and evasion techniques, potentially increasing its effectiveness across various scenarios. Given the resource-intensive nature of RL models, research into optimising them for computational efficiency is critical. To make the RL model work better in a constrained environment, especially in places with limited resources, we could look into model pruning, quantization, or using more efficient neural network architectures.

Instead of operating in isolation, the RL model should integrate with existing security tools and infrastructure. Such integration could leverage the strengths of existing post-incident forensic processes as well as RL's adaptive learning capabilities to provide a more layered and robust defence mechanism against malware forensics. Cyber threats continually evolve, necessitating ongoing updates and evaluations of the RL model. Implementing a mechanism for continuous learning and adaptation will ensure that the model remains effective against new and emerging malware. It's important to consider the ethical implications and security vulnerabilities inherent in deploying AI in cybersecurity. Since our implemented environments are 'living environments' that can easily change due to new workflow processes, we should address the potential for adversarial attacks against the model itself to ensure that the security measures keep up with advancements in AI technology. Implementing these recommendations can enhance the identification of malware samples and adapt to evolving cyber threat investigations. This will not only expedite the examination and analysis of evidence, but it will also reduce the frequency of significant errors and 'miscarriages of justice' in the UK's justice system.

The Moore article [30], "*Rethinking Miscarriages of Justice: Beyond the Tip of the Iceberg*," explores the systemic flaws within the UK's criminal justice system that lead to frequent miscarriages of justice. The author highlights that these errors are more pervasive than commonly recognised due to fundamental limitations in legal procedures and evidence handling. To address these issues, the developed post-incident malware forensic investigation model and framework could introduce a data-driven, unbiased approach to digital forensic analysis. As a result of leveraging reinforcement learning and comprehensive open-source knowledge, this model could enhance the accuracy and reliability of forensic investigations, reducing the risk of wrongful convictions and improving judicial outcomes.

VII. CONCLUSION

This paper proposes a new model and framework for advanced reinforcement learning post-incident malware forensics investigations. This model and framework can not only speed up malware forensics investigations beyond what a human forensic expert can do, but it can also find

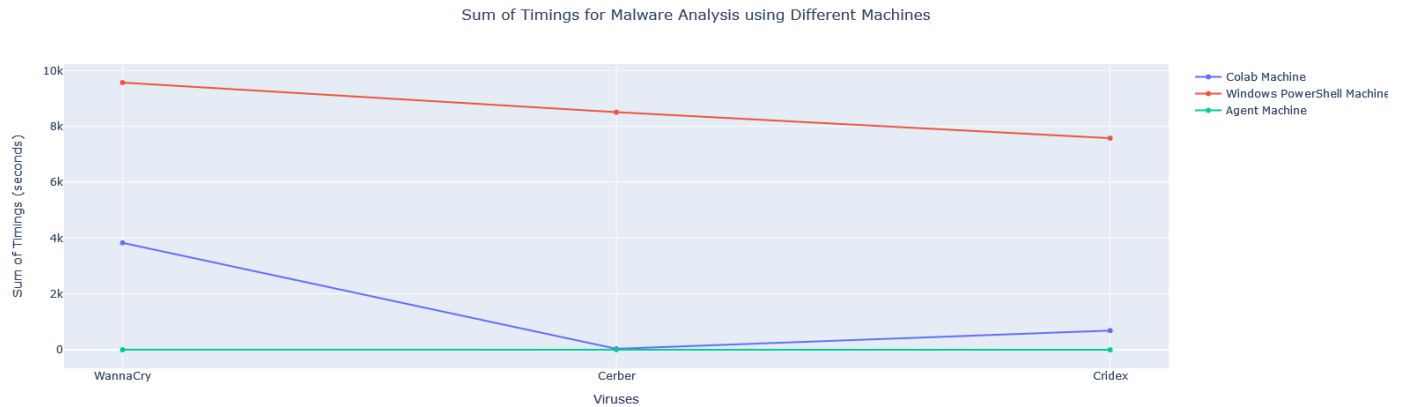

Fig. 21: Total time spent on malware analysis using Collab, PowerShell, and RL Agent

both known and unknown malware threats. We design the model to support various malware analysis techniques and data collection methods, including live memory dumps from Windows systems. We generated a malware dataset and created a robust malware workflow diagram. We develop a unified Markov Decision Process (MDP) model that integrates multiple MDPs into a comprehensive framework. We create three MDP environments: **BlankEnvironment**, **BlankEnvironment_with_Rewards**, and **BlankEnvironment_with_Time**, each featuring unique reward mechanisms to encourage the learning agent to perform optimal malware analysis. **BlankEnvironment** uses a standard reward system, assigning negative rewards for each step and positive rewards for identifying malware. **BlankEnvironment_with_Rewards** provides higher positive rewards for accurate early-stage malware identification across all terminal states, whereas **BlankEnvironment_with_Time** imposes severe penalties for unnecessary steps to promote efficiency.

The Reinforcement Learning Post-Incident Malware Investigation Model operates in a structured MDP environment, allowing the reinforcement learning agent to move between the different states of the malware analysis workflow diagram. The model links each state and action to specific parts of the malware analysis workflow diagram, enabling the agent to estimate the expected value of actions and refine its policy over time. In these environments, we implement a Q-learning algorithm, demonstrating significant improvements in the agent's ability to identify malware by performing various actions in different states. Actions range from collecting and analysing data to making decisions based on the processed information. This approach leverages exploration and exploitation principles inherent to RL, allowing the model to adapt and improve its malware analysis capabilities through iterative learning. The epsilon-greedy exploration strategy and Q-learning updates facilitated efficient learning and decision-making processes, as evidenced by the stored values used to get more insights on how the agent decision-making process plays out. The model uses a Q-table for managing state-action

pairs, combined with temporal difference learning, enabling the agent to update its knowledge base iteratively. This method allowed the agent to estimate the expected value of actions and refine its policy over time, leading to improved performance in malware identification tasks.

Extensive experimental testing evaluates the effectiveness of the developed models, revealing that the optimal learning rate depends on the environment's complexity. Simpler environments benefit from moderate to high learning rates for quicker convergence, while more complex environments require a lower learning rate to ensure stability and prevent the agent from oscillating between suboptimal policies. In post-incident malware forensic investigations, we simulated real-world scenarios to evaluate the models' ability to identify and classify malware, aiming to reduce analysis time compared to human experts. We measured the models' performance across metrics like accuracy and adaptability to new malware types, which was essential for refining the models to meet performance criteria. We tested the models against various malware types, such as WannaCry, Cerber, and Cridex, to analyse execution times and the agent's ability to converge to an optimal policy, thereby showcasing their robustness. We achieved continuous learning and adaptation through rigorous testing and hyperparameter tuning, thereby enhancing the models' long-term effectiveness. The research used feedback from experimental results to iterate on the three environments, resulting in the validation of the developed Reinforcement Learning Post-Incident Malware Investigation Framework. This iterative process highlighted the importance of hyperparameter tuning, particularly the learning rate, which significantly affects performance and efficiency in various environments. The reinforcement learning-based approach for post-incident malware forensics investigations offers a promising alternative to traditional methods, as it can adapt to new and evolving malware threats. The positive results suggest potential for further research and development, particularly in optimising reward mechanisms, state space design, and integrating additional features.

- [1] Quertier, T., Marais, B., Morucci, S. and Fournel, B., 2022. MERLIN—Malware Evasion with Reinforcement Learning. arXiv preprint arXiv:2203.12980. Available at: <https://arxiv.org/abs/2203.12980>
- [2] Aslan, Ö.A. and Samet, R., 2020. A comprehensive review on malware detection approaches. *IEEE access*, 8, pp.6249-6271. <https://ieeexplore.ieee.org/document/8949524>
- [3] Akhtar, M.S. and Feng, T. 2022. Malware Analysis and Detection Using Machine Learning Algorithms. *Symmetry* 14(11), p. 2304. Available at: <http://dx.doi.org/10.3390/sym14112304>
- [4] Dunsin, D., Ghanem, M.C. and Ouazzane, K., 2022. The use of artificial intelligence in digital forensics and incident response in a constrained environment. *International Journal of Information and Communication Engineering*, 16(8), pp.280-285.
- [5] Fang, Z., Wang, J., Li, B., Wu, S., Zhou, Y. and Huang, H. (2019). Evading Anti-Malware Engines With Deep Reinforcement Learning. *IEEE Access* 7, pp. 48867–48879. Available at: <https://ieeexplore.ieee.org/document/8676031>
- [6] Wu, C., Shi, J., Yang, Y. and Li, W., 2018, November. Enhancing machine learning based malware detection model by reinforcement learning. In *Proceedings of the 8th International Conference on Communication and Network Security* (pp. 74-78). <https://dl.acm.org/doi/abs/10.1145/3290480.3290494>
- [7] Piplai, A., Ranade, P., Kotal, A., Mittal, S., Narayanan, S.N. and Joshi, A., 2020, December. Using knowledge graphs and reinforcement learning for malware analysis. In *2020 IEEE International Conference on Big Data (Big Data)* (pp. 2626-2633). IEEE. <https://ieeexplore.ieee.org/document/9378491>
- [8] Farzaan, M.A., Ghanem, M.C. and El-Hajjar, A., 2024. AI-Enabled System for Efficient and Effective Cyber Incident Detection and Response in Cloud Environments. <https://arxiv.org/abs/2404.05602>
- [9] Ghanem, M.C., Mulvihill, P., Ouazzane, K., Djemai, R. and Dunsin, D., 2023. D2WFP: a novel protocol for forensically identifying, extracting, and analysing deep and dark web browsing activities. *Journal of Cybersecurity and Privacy*, 3(4), pp.808-829. Available at: <https://doi.org/10.3390/jcp3040036>.
- [10] Fang, Z., Wang, J., Geng, J. and Kan, X. 2019. Feature Selection for Malware Detection Based on Reinforcement Learning. *IEEE Access* 7, pp. 176177–176187. Available at: <https://ieeexplore.ieee.org/document/8920059>.
- [11] Binxiang, L., Gang, Z., and Ruoying, S. (2019, December). A deep reinforcement learning malware detection method based on PE feature distribution. In *2019 6th International Conference on Information Science and Control Engineering (ICISCE)* (pp. 23-27), Shanghai, China, 2019, pp. 23-27, <https://ieeexplore.ieee.org/document/9107644>
- [12] Ebrahimi, M., Pacheco, J., Li, W., Hu, J. L., and Chen, H. (2021, May). Binary Black-Box Attacks Against Static Malware Detectors with Reinforcement Learning in Discrete Action Spaces. In *2021 IEEE Security and Privacy Workshops (SPW)*, San Francisco, CA, USA, 2021, pp. 85-91, <https://ieeexplore.ieee.org/document/9474314>
- [13] Raff, E., Barker, J., Sylvester, J., Brandon, R., Catanzaro, B. and Nicholas, C.K., 2018, June. Malware detection by eating a whole exe. In *Workshops at the thirty-second AAAI conference on artificial intelligence*. <https://doi.org/10.13016/m2rt7w-bkok>
- [14] Szegedy, C., Zaremba, W., Sutskever, I., Bruna, J., Erhan, D., Goodfellow, I., and Fergus, R. (2013). Intriguing properties of neural networks. *ArXiv: Computer Vision and Pattern Recognition*. <http://export.arxiv.org/pdf/1312.6199>
- [15] Silver, D., Huang, A., Maddison, C.J., Guez, A., Sifre, L., den Driessche, G. van, Schrittwieser, J., Antonoglou, I., Panneershelvam, V., Lanctot, M., Dieleman, S., Grewe, D., Nham, J., Kalchbrenner, N., Sutskever, I., Lillicrap, T., Leach, M., Kavukcuoglu, K., Graepel, T., Hassabis, D., 2016. Mastering the game of Go with deep neural networks and tree search. *Nature* 529(7587), pp. 484–489. Available at: <http://dx.doi.org/10.1038/nature16961>
- [16] Song, W., Li, X., Afroz, S., Garg, D., Kuznetsov, D., and Yin, H. (2020). Mab-malware: A reinforcement learning framework for attacking static malware classifiers. <https://arxiv.org/abs/2003.03100>
- [17] Anderson, H. S., Kharkar, A., Filar, B., Evans, D., and Roth, P. (2018). Learning to evade static PE machine learning malware models via reinforcement learning. <https://arxiv.org/abs/1801.08917>
- [18] Dunsin, D., Ghanem, M.C., Ouazzane, K., Vassilev, V., 2024. A comprehensive analysis of the role of artificial intelligence and machine learning in modern digital forensics and incident response. *Forensic Science International. Digital Investigation* 48, 301675. <https://doi.org/10.1016/j.fsidi.2023.301675>
- [19] Gallant, S.I., 1990. Perceptron-based learning algorithms. *IEEE Transactions on Neural Networks* 1, 179–191. <https://doi.org/10.1109/72.80230>
- [20] Birman, Y., Hindi, S., Katz, G., and Shabtai, A. (2020, May). Cost-effective malware detection as a service over serverless cloud using deep reinforcement learning. In *2020 20th IEEE/ACM International Symposium on Cluster, Cloud and Internet Computing (CCGRID)*, Melbourne, VIC, Australia, 2020, pp. 420-429, doi: <https://ieeexplore.ieee.org/document/9139646>
- [21] Anderson, H.S., Kharkar, A., Filar, B. and Roth, P., 2017. Evading machine learning malware detection. *black Hat*, 2017, pp.1-6. Available at: <https://www.blackhat.com/docs/us-17/thursday/us-17-Anderson-Bot-Vs-Bot-Evading-Machine-Learning-Malware-Detection-wp.pdf>
- [22] Molloy, C., Ding, S. H., Fung, B. C., and Charland, P. (2022, July). H4rm0ny: A Competitive Zero-Sum Two-Player Markov Game for Multi-Agent Learning on Evasive Malware Generation and Detection. In *2022 IEEE International Conference on Cyber Security and Resilience (CSR)* (pp. 22-29). <https://ieeexplore.ieee.org/document/9850345>
- [23] Chen, Z., Hu, J., and Min, G. (2019, May). Learning-Based Resource Allocation in Cloud Data Center using Advantage Actor-Critic. In *ICC 2019-2019 IEEE International Conference on Communications (ICC)* (pp. 1-6). <https://ieeexplore.ieee.org/document/8761309>
- [24] Yuan, X., He, P., Zhu, Q. and Li, X. 2019. Adversarial Examples: Attacks and Defenses for Deep Learning. *IEEE Transactions on Neural Networks and Learning Systems* 30(9), pp. 2805–2824. Available at: <http://dx.doi.org/10.1109/tnnls.2018.2886017>
- [25] Liu, Y., Tantithamthavorn, C., Li, L., and Liu, Y. (2022). Deep Learning for Android Malware Defenses: A Systematic Literature Review. *ACM Computing Surveys*, 55(8), 1–36. <https://doi.org/10.1145/3544968>
- [26] Zhou, Y., Kantarcioglu, M., and Xi, B. (2018). A survey of game theoretic approach for adversarial machine learning. *WIREs Data Mining and Knowledge Discovery*, 9(3). <https://doi.org/10.1002/widm.1259>
- [27] Anderson, H.S., Woodbridge, J., and Filar, B., (2016). DeepDGA: Adversarially-tuned domain generation and detection. In *Proceedings of the 2016 ACM workshop on artificial intelligence and security* (pp. 13-21). <https://dl.acm.org/doi/10.1145/2996758.2996767>
- [28] Rakhsha, A., Radanovic, G., Devidze, R., Zhu, X. and Singla, A., (2021). Policy teaching in reinforcement learning via environment poisoning attacks. *The Journal of Machine Learning Research*, 22(1), pp.9567-9611. <https://arxiv.org/abs/2003.12909>
- [29] Adamov, A. and Carlsson, A., 2020, September. Reinforcement learning for anti-ransomware testing. In *2020 IEEE East-West Design and Test Symposium (EWDTS)* (pp. 1-5). IEEE. Available at: <https://ieeexplore.ieee.org/abstract/document/9225141>
- [30] Moore, L., 2009. Review: Rethinking Miscarriages of Justice: Beyond the Tip of the Iceberg Michael Naughton Palgrave Macmillan, Houndsmills, 2008, 233pp, ISBN 978—0—230—01906—5, £45.00 (hbk). *Critical Social Policy* 29, 296–297. <https://doi.org/10.1177/02610183090290020702>