

Crosstalk Attacks and Defence in a Shared Quantum Computing Environment

Benjamin Harper,^{1,2} Behnam Tonekaboni,² Bahar Goldozian,² Martin Sevier,¹ and Muhammad Usman^{1,2}

¹*School of Physics, The University of Melbourne, Parkville, 3010, Victoria Australia*

²*Quantum Systems, Data61, CSIRO, Clayton, 3168, Victoria Australia*

Quantum computing has the potential to provide solutions to problems that are intractable on classical computers, but the accuracy of the current generation of quantum computers suffer from the impact of noise or errors such as leakage, crosstalk, dephasing, and amplitude damping among others. As the access to quantum computers is almost exclusively in a shared environment through cloud-based services, it is possible that an adversary can exploit crosstalk noise to disrupt quantum computations on nearby qubits, even carefully designing quantum circuits to purposely lead to wrong answers. In this paper, we analyze the extent and characteristics of crosstalk noise through tomography conducted on IBM Quantum computers, leading to an enhanced crosstalk simulation model. Our results indicate that crosstalk noise is a significant source of errors on IBM quantum hardware, making crosstalk based attack a viable threat to quantum computing in a shared environment. Based on our crosstalk simulator benchmarked against IBM hardware, we assess the impact of crosstalk attacks and develop strategies for mitigating crosstalk effects. Through a systematic set of simulations, we assess the effectiveness of three crosstalk attack mitigation strategies, namely circuit separation, qubit allocation optimization via reinforcement learning, and the use of spectator qubits, and show that they all overcome crosstalk attacks with varying degrees of success and help to secure quantum computing in a shared platform.

I. INTRODUCTION

In the pursuit of achieving scalability and performance in quantum computing, efficient control and mitigation of noise are essential for the high-fidelity implementation of quantum algorithms of practical interest. Noise in quantum computers may take several forms including environmental noise that causes decoherence in qubits via dephasing and relaxation processes; also, computational gates and measurement operations on qubits may result in imperfect fidelities [1, 2]. In addition to the aforementioned sources of noise, qubits connectivity—which is essential in executing multi-qubit gates—could lead to the emergence of unwanted correlated dynamics. These correlated dynamics give rise to an important type of noise known as crosstalk noise [3–6], which results in a decline in quantum coherence and the introduction of errors in quantum computations.

It is noted that the word *crosstalk* is often used in the fields of electrical engineering and communication theory to describe the phenomenon of unwanted signal coupling across different pathways [7]. However, in quantum computing, the term is adapted to describe a variety of physical phenomena when an undesired influence is exerted by one subsystem of an experimental apparatus, such as a qubit or control pulse, on another qubit. Consider superconducting qubits, such as those used in IBM devices, as an example. The qubits in these devices are placed in a certain topology, with each qubit connected to one, two, or more neighbor qubits. A cross-resonance pulse will then be utilized to apply a two-qubit gate to a pair of linked qubits [5, 6]. While this *always-on* coupling, utilises the two-qubit gates, they also result in an undesirable crosstalk effect. This is depicted in the top image of FIG. 1(a), where a single qubit gate pulse targets only the center qubit, but due to physical coupling, there is

undesired crosstalk on the neighbor qubits. Even with quantum platforms without always-on coupling, such as atomic qubits, the profile of the laser gate pulse may leak to the side atoms and adversely affect them [8]. The bottom image of FIG. 1(a) illustrates this mechanism.

While crosstalk is expected to be present in all quantum devices and suppressing crosstalk in quantum computers is an active topic of research (see [9–11] as examples), here we investigate crosstalk as a substantial security concern. It is almost certain that functional quantum computers will be operated as multi-user facilities, executing circuits for multiple users simultaneously, including public access through cloud platforms. Since the operations of neighboring circuits affect each other through crosstalk, it is possible to craft an algorithm that can interfere with nearby normal operations, causing programs to fail, provide faulty results, or leak information. This could be exploited by an adversary or deployed against an adversary’s quantum computer operations [12]. An illustration of one such scenario is shown in FIG. 1(b) exhibiting a malicious actor interfering with an algorithm employed on a multi-user quantum computer.

To demonstrate a crosstalk attack, we executed a three-qubit Grover algorithm with a target answer of ‘110’, on an IBM device. The experiment encompassed two scenarios: one without any external interference and the other with the imposition of a crosstalk attack. The crosstalk attack was implemented through a series of CNOT gates on two proximate qubits. Top row of FIG. 1(c) shows the circuit diagram of the experiment and the histogram in this figure shows the results of the experiment. In the absence of any attack, the majority of counts are the target answer. In contrast, when subjected to the attack, the target result is wiped out and the histogram shows an approximately uniform distribution of counts.

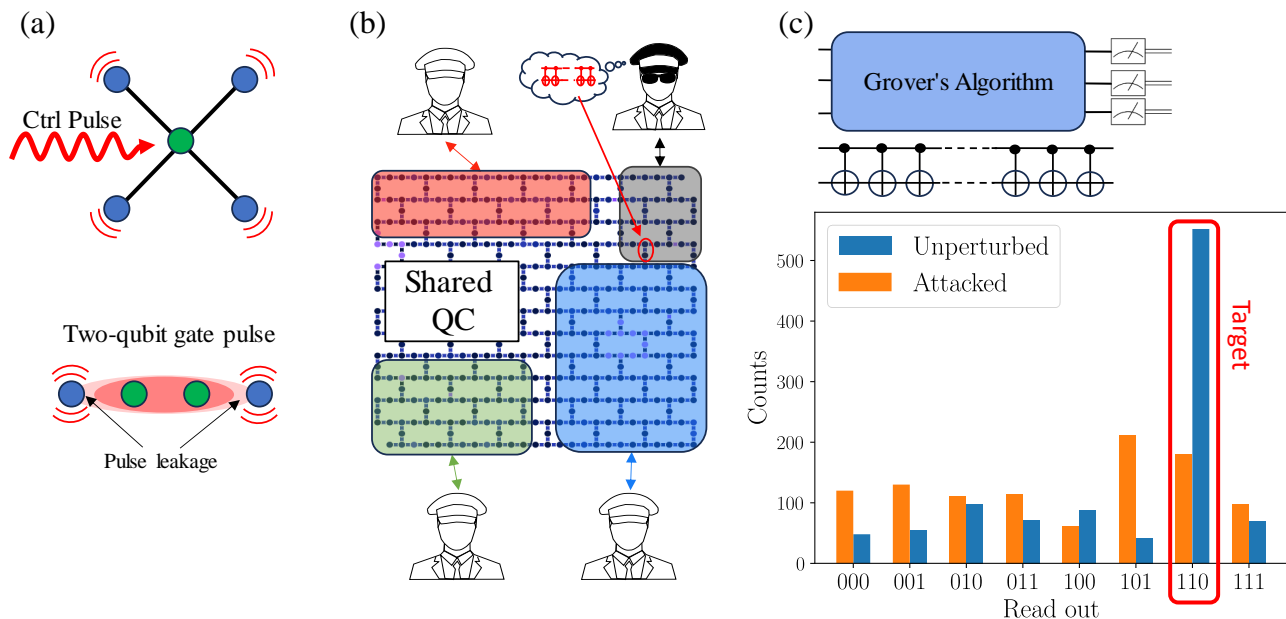

FIG. 1. (a) Illustration of crosstalk effect mechanism. (Top) shows the crosstalk effect due to the always on coupling between qubits, the coupling is demonstrated with solid lines. Although the control pulse (red wavy arrow) aims only the target qubit (green) in the middle, neighbour qubits (blue) are affected. (Bottom) depicts the leakage of a two-qubit gate that aims only two middle qubits (green). Although there is no link between the qubits, the leakage of the two-qubit gate affects the neighbour qubits. (b) Illustration of a future shared Quantum Computer with multiple users each running their own programs. A malicious actor has gained access and can employ crosstalk attacks against other programs (background is IBM 433-Qubit Osprey device). (c) Top: We implement Grover’s algorithm with the target of “6” on a real 5-qubit IBM Quantum computer. Qubits 0-2 implement Grover’s algorithm while on qubits 3 and 4 we implement a series of CNOT gates. (Bottom) When the qubits 3 and 4 are not operating, the circuit returns the blue histogram, showing normal operation. When we also apply CNOT operations on qubits 3 and 4, we instead observe the orange histogram showing crosstalk from the CNOT gates completely overwhelming the operation of the circuit.

It is important to note that crosstalk attacks are distinctly different from malware-based attacks on conventional computers. Crosstalk noise is inherent in the actual physics of the operation of the quantum computer and this kind of attack vector is simply not possible in conventional computers. Therefore, defending against these attacks requires strategies in addition to normal security procedures.

Despite significant evidence highlighting the potential security implications of crosstalk attacks on quantum processors, there is currently a lack of quantitative modelling and practical mitigation strategies for real devices. Addressing this gap is the primary objective of this paper. The structure of the paper is as follows. First in Sec. II, we characterize crosstalk noise on an IBM device. This characterization will be the framework for simulating circuits under the effects of crosstalk noise in the rest of the paper. Then, in Sec. III, we present three techniques to detect and mitigate the effects of a crosstalk attack on a circuit. The first technique (Sec. IIIA) employs unused buffer qubits to distance the circuits from potential crosstalk attacks. This technique also provides an indication of the extent of crosstalk noise in an IBM device, laying the foundation for basic understanding of the severity of such noise mechanism. The second technique

(Sec. IIIB) employs a reinforcement machine learning approach and uses the noise model of the device to position circuits such that the potential for crosstalk noise to impact their performance is minimised. The final technique (Sec. IIIC) employs extra qubits, but in contrast to first technique these extra qubits are used as spectator qubits. By measuring the spectator qubits at the correct interval, it is possible to detect the presence of an attack with a high level of confidence. Finally, in Sec. IV, we discuss the importance of the security implications of crosstalk attacks and our successful strategies to mitigate them.

II. CHARACTERISING AND SIMULATION OF CROSSTALK ON IBM DEVICES

Essential to our work in this paper is a realistic characterisation of the noise due to crosstalk in a physical device. For this, we opted to use idle tomography [13]. The Python library PyGSTi [14] is used to perform the idle tomography calculations, and also simulate circuits with crosstalk noise. We benchmark crosstalk on a real quantum device, `ibm.hanoi`, and use this data to prepare the crosstalk simulator. We then run validation circuits on the crosstalk simulator, the real device, and

other existing quantum software simulators to verify that the crosstalk simulator is an accurate representation of real devices.

A. Idle Tomography

Idle tomography (IDT) [13], as the name suggests, seeks to characterise the idle error rates of qubits on a physical device. To do this, a family of tomography circuits is prepared. The circuits we used consist of three parts; preparation, idling and un-preparation, as shown in FIG. 2(a). In the preparation step, each circuit initialised in the $|0\rangle$ state and is prepared in a unique Pauli basis. In the second phase, the qubits are left to idle for a variable period of time (measured in gate lengths). Finally, the state preparation is undone. In a noise-free quantum computer, this returns the state to $|0\rangle^n$. In a noisy device, however, the measurement results will be perturbed away from the target distribution. A large number of circuits in this form are generated, where only the Pauli state preparation is changed.

The noise channel modelled by idle tomography in PyGSTi is the reduced HSA model [13],

$$\mathcal{L} = \mathcal{H} + \mathcal{S} + \mathcal{A}. \quad (1)$$

This model has three components; Hamiltonian errors (\mathcal{H}) are the rate of over (under) rotation induced on a specific Pauli axis. The stochastic error rate (\mathcal{S}) is the probability of a random Pauli X , Y or Z error. Finally affine errors (\mathcal{A}) correspond to non-unitary noise processes.

The information contained in the probability distribution of a circuit's output scales exponentially with the number of qubits — as there are an exponential number of outcomes. Conversely, the number of parameters in the reduced HSA model scales polynomially with the number of qubits in the device. As such, the number of experiments which need to be performed to benchmark a device increases logarithmically with the number of qubits [13], though the number of shots for each experiment to obtain a good probability distribution increases exponentially.

When considering the noise due to gates on a quantum computer, we typically look at the qubits on which the gate is applied. In crosstalk noise, we are interested in the noise that a gate causes on *other* qubits around it. In effect, we want to know the idle error rate of qubits in the device when a gate is being applied to neighbouring qubits. Thus, to quantify the crosstalk error rates due to an m -qubit gate U on an n -qubit device, we choose m qubits on which we want to benchmark the gate. On the remaining $n - m$ qubits, idle tomography is performed. While the IDT qubits are idling, the gate U is performed in parallel. The presence of crosstalk in the device means that U will cause errors in the IDT qubits.

In this work, we benchmark a 27-qubit IBM device — `ibm.hanoi`. We benchmark crosstalk due to the 2-qubit

CNOT gate, which requires running 165 benchmark circuits per CNOT benchmarked. These results were then postprocessed classically to produce a realistic simulator with crosstalk noise.

B. Simulation of Crosstalk

Having created a crosstalk-aware classical simulator, it is necessary that we validate that its performance matches that of the real device it is based on. To perform this validation of the crosstalk simulator, we ran five benchmark circuits and compared the results to the real quantum device, as well as other simulation methods. Ideally, our simulator will be a better model of the real device in circuits with a large amount of crosstalk, induced by CNOT gates. The output of these experiments is a set of counts, which is used to approximate the probability distribution of that quantum circuit. A good simulator should have a similar probability distribution to the output distribution of the real device. The metric used to measure performance is the Total Variational Distance (TVD) [15], which measures the distance between probability distributions in the L_∞ metric. The TVD is explained further in appendix A.

In FIG. 2(b) we show TVD relative to the real device for three scenarios: 1) *No Noise*, a noise free simulation of the circuit, 2) *Dephasing Noise*, simulation using dephasing noise from the builtin noise model in IBM's QISKIT package which does not include crosstalk, and 3) *Crosstalk Noise*, the noisy simulation that we developed for this paper. The TVD is measured relative to the results from running each circuit on the real device. As such, a lower TVD means that the simulator is a better representation of the real device. In this case, crosstalk noise is a significant source of noise in the device, hence the crosstalk simulator is closest in TVD to the real device. We then compare these three scenarios on five different test cases: 1) The *syn10* and 2) *syn30* test cases are synthetic circuits of a repeated CNOT next to an idling qubit — similar to the idle tomography circuits used to derive the noise models, 3) the *grover3* test is a 3-qubit Grover's algorithm with two iterations, 4) the *toffoli* test is a sequence of repeated Toffoli gates, which is itself decomposed into CNOT gates and single qubit rotations, 5) the *attack* test case is a Grover's algorithm circuit in the presence of a CNOT attack. Circuit diagrams for these test circuits are given in appendix B. FIG. 2(c) and (d) show the simulated probability distribution for two of these test cases, illustrating how the crosstalk simulator counts are much closer to the real device than other simulation techniques.

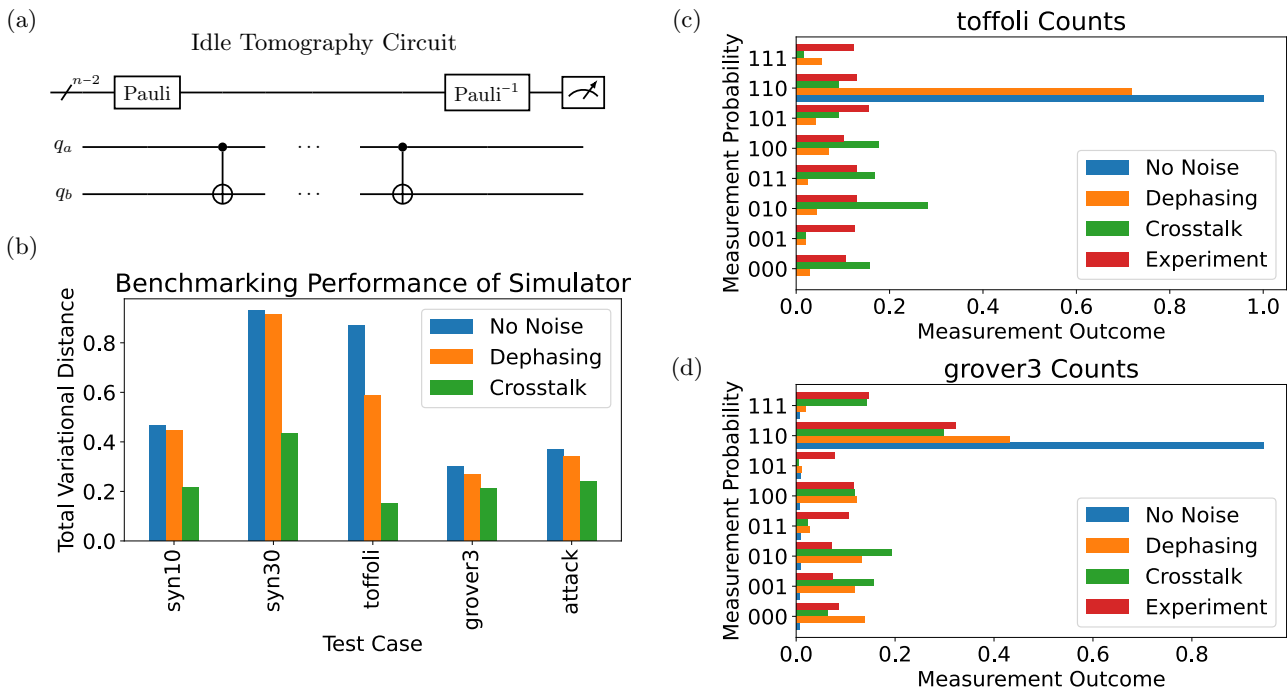

FIG. 2. (a) Example of an idle tomography circuit for benchmarking crosstalk. Here we are benchmarking the crosstalk due to a CNOT between qubits q_a and q_b , with idle tomography being performed on the remaining $n - 2$ qubits on the device. The tomography qubits are prepared into a Pauli basis state, then left to idle while CNOTs are applied between qubits q_a and q_b . At the end of the circuit, the state preparation is undone, leaving the qubits in the $|000\rangle$ state in a noise-free environment. (b) We now investigate the performance of our simulator through benchmarking. A variety of benchmark circuits are run on a real device, and three simulators. A description of the simulation techniques and benchmark circuits is provided in the main text. Performance of the simulation techniques is judged using Total Variational Distance (see text), with the device noise at 0 used as a reference point. Lower is better. (c) and (d) present the measured counts in two of the test cases, (c) Toffoli, (d) Grover. In both cases the target circuit output is $|110\rangle$. The target output distribution for each simulation technique is to match the experiment results.

III. CROSSTALK DETECTION AND MITIGATION

In this section we explore various techniques to detect and/or mitigate a crosstalk attack. For all the techniques discussed, we use the same model of attack; that is, a hostile user with the ability to craft a repeated CNOT circuit (illustrated in FIG. 1(c)) maximising crosstalk. We note that in principle a variety of attacks can be designed by using different types of quantum gates or their combinations, as many quantum gates can induce crosstalk [16]. However, in this work we use only CNOT gates as a proof-of-concept demonstration.

A. Mitigation by Circuit Separation

We begin with a study of how the strength of crosstalk changes across the device. While generally crosstalk is a non-local effect, such that quantum gates may affect neighbouring qubits, we expect it to be relatively local, i.e. the qubits most affected by crosstalk from an

operation are the ones physically closest to that operation. Here we define the radius of separation, r , to be the number of idle qubits on the shortest path between two algorithms on a device's graph of connectivity. Note that this may not correspond perfectly to the physical distance between qubits, it is a useful approximation. A recent study [16] has found that while adjacent computations can adversely affect each other, only a small radius of separation is required to mitigate this. Our work extends further, by exploring the effect when one of the computations is not useful, but in fact a CNOT-dense attack designed specifically to disrupt neighbouring computations.

To test this, we created a circuit containing Grover's algorithm, and placed next to it a repeated CNOT attack as described above, where every layer in the Grover circuit is accompanied by a CNOT gate on the neighbouring attack qubits. The distance of separation between the algorithm and the attack was then increased progressively, and the resulting probability distributions are compared in FIG. 3. The results show a high level of variance in the effect of crosstalk on the device — while some configura-

tions with a separation of zero between the circuit and the attack show a significant deterioration in performance, some configurations are nearly unaffected. Increasing the radius of separation between circuits increases the average fidelity, and also reduces the variance between outcomes. This indicates that the radius of separation is unnecessarily heavy handed — FIG. 3(a) shows how a significant fraction of the device must be left idle for even a small radius of separation, while FIG. 3(b) shows that for some configurations, only a small or zero separation is necessary to prevent interference. This implies that intelligent selection of qubits could allow circuits to be placed close to each other without crosstalk interference between them. To address these issues, a machine learning approach is developed below, which will scale to larger devices and automate the process of identifying good qubits.

B. Mapping Circuits with Reinforcement Learning

As discussed in the introduction, crosstalk error arises from the unwanted effects of controls on nearby qubits. Consequently, the allocation of physical qubits for a given algorithm will influence the impact of crosstalk error. Thus, finding the optimal qubit allocation is a crucial task to achieve the optimal accuracy of computation. In this section, we utilize reinforcement learning (RL) to mitigate crosstalk noise by optimizing qubit allocation. The proposed method improves circuit fidelity by identifying and implementing practical mapping computations onto qubits that show reduced crosstalk errors.

Our method uses RL, a process in which an algorithm iteratively refines its decision-making through feedback from a structured training regimen [17]. In our specific context, the algorithm learns to map a target circuit to physical qubits, taking into account the quantum computer’s noise profile, particularly crosstalk, and identifying the mapping that minimizes errors. Previous studies [18, 19] have demonstrated the effectiveness of RL in reducing such errors. The proposed method will be discussed in more detail in the following section.

1. Methodology and Definition of Framework Components

Our framework aims to develop a trained policy network capable of effectively mapping quantum circuits to physical qubits, which is illustrated in FIG. 4. The main components of an RL method are *action*, *RL-state* and *policy*. In our model these components are as follows.

The “action” in our RL model represents the allocation of qubits to physical qubits on the quantum computer. These actions are constrained by the hardware’s topological limitations, dictating the possible interactions between qubits. The number of actions is a hyperparameter of our model. Central to our RL model’s framework is the “RL-state,” which represents the current configuration of

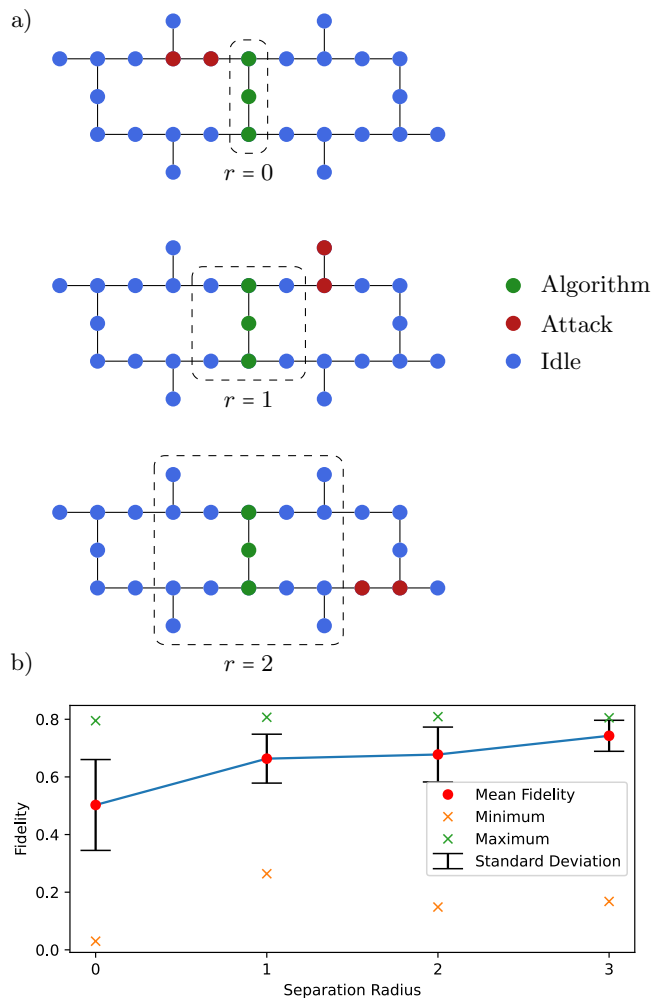

FIG. 3. a) Circuits may be placed on the device with a separation radius between them. Here we place a circuit performing Grover’s algorithm in green, while in red is a repeated CNOT attack. Attacks may be placed anywhere outside the radius of separation. b) When the circuits are directly adjacent, the output fidelities of Grover’s algorithm are largely noise. If the separation radius between the circuits is increased, the output fidelities return towards the ideal distribution.

the quantum circuit. The RL state includes factors such as the number of qubits and the sequence of quantum gates.

The policy network acts as the decision-making component within the reinforcement learning framework. Our policy is represented by a neural network with two layers, which through the use of gradient descent, learns to optimize the mapping of qubits to their physical counterparts. Through an iterative process shown in FIG. 4, or as pseudocode in algorithm 1, the neural network continuously learns by processing the current state of the quantum circuit and evaluating each mapping’s effectiveness.

The effectiveness of each action is assessed through a designed reward function. The reward is calculated in

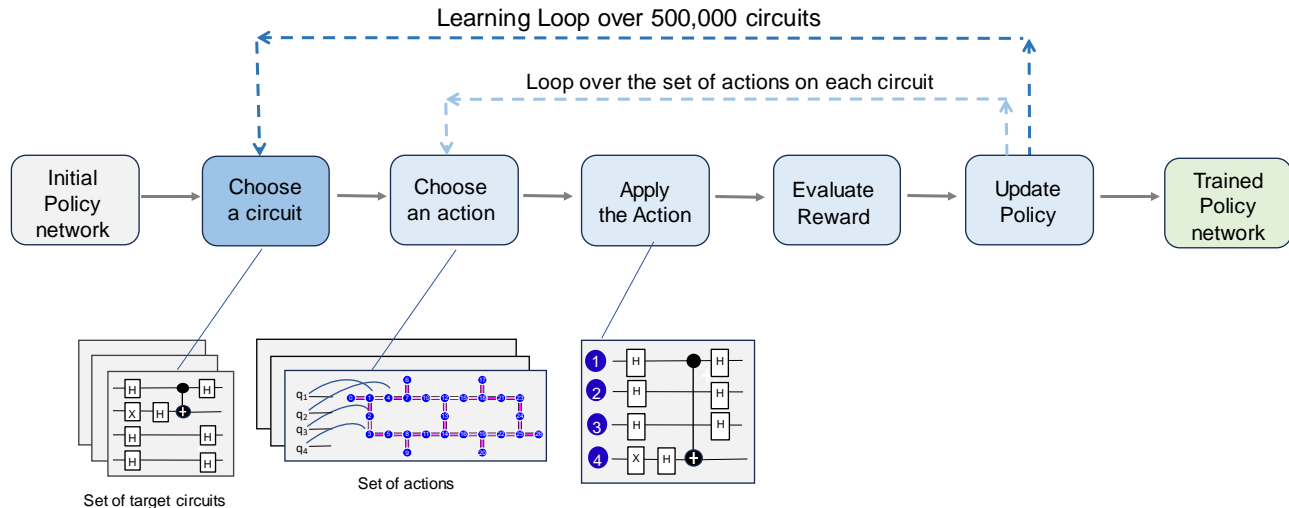

FIG. 4. The flowchart shows the learning cycle for optimizing quantum circuit mapping. It begins with an initial, untrained policy network. In each iteration, the network picks a circuit, and for each circuit, it evaluates different mappings (actions). The number of actions is defined as a hyperparameter within the policy network. The efficacy of each action is assessed through a reward system, which informs the policy network. After training, the trained policy network can be applied to a new circuit, using its learned strategies to predict the optimal qubit mapping. Pseudocode describing the learning cycle is also shown in algorithm 1

terms of the fidelity of the executed circuit. This reward guides the policy network to identify the optimal mappings. Over time, the network learns to choose mappings that enhance circuit performance consistently. After the policy network has completed a set of actions and received the corresponding feedback, it updates its policy using gradient descent. Once the policy is updated, the network proceeds to the next quantum circuit. The dark blue loop shown in the FIG. 4 encircles the set of target circuits, which are the training data for our model. In each loop a new quantum circuit is introduced to the policy network. The network processes this circuit to decide which action to take. Once an action is taken, the network reviews the results to learn from its decision. This review process is critical because it provides feedback that the policy network uses to refine its parameters. As a result, the policy network’s ability to select the most rewarding actions is progressively enhanced through this iterative learning.

Once training is complete, the trained policy network can receive any quantum circuit and efficiently predict its optimal mapping. This is a critical feature of the model, as it allows for practically applying the policy network’s learned strategies to new, unseen quantum circuit configurations.

Another significance of our method is its adaptability to varying noise. Since noise landscape in quantum computers changes on daily basis adaptability to is essential. Therefore, the ability to update mappings without complete re-training is crucial. This process begins with a trained reinforcement learning model familiar with a specific noise environment. The model then undergoes

partial re-training using data that reflects the latest noise profiles, which could influence qubit allocation.

2. Results

To achieve the objective of having a robust model, we need a large set of data. Note that covering every possible permutation of circuits is time consuming and impractical due to the massive variety of potential quantum circuit combinations. Despite this barrier, our data set is sufficient for our object as we discuss below.

The number of circuits that the model trains are defined as a hyperparameter, we trained on a dataset containing 500,000 different circuits. These training circuits were randomly generated, with a uniform distribution of gates, and a uniform random number of up to 5 qubits and 20 gates chosen. We included various circuit configurations with different numbers of qubits, gates, and types of gates to ensure our dataset was comprehensive. It allows our model to learn how to handle a wide selection of quantum circuit setups effectively. A repository of these circuits is available upon request.

Examples of our trained model are illustrated in FIG. 5. In this figure, we compare the performance of the RL-based circuit mapping to that of an initial mapping. The initial mapping we refer to is a linear mapping approach where the first qubit is mapped onto the first physical qubit (qubit 0), the second qubit to the second physical qubit (qubit 1), and so on sequentially. This comparison highlights the effectiveness of RL-based circuit mapping over initial mapping under various noise

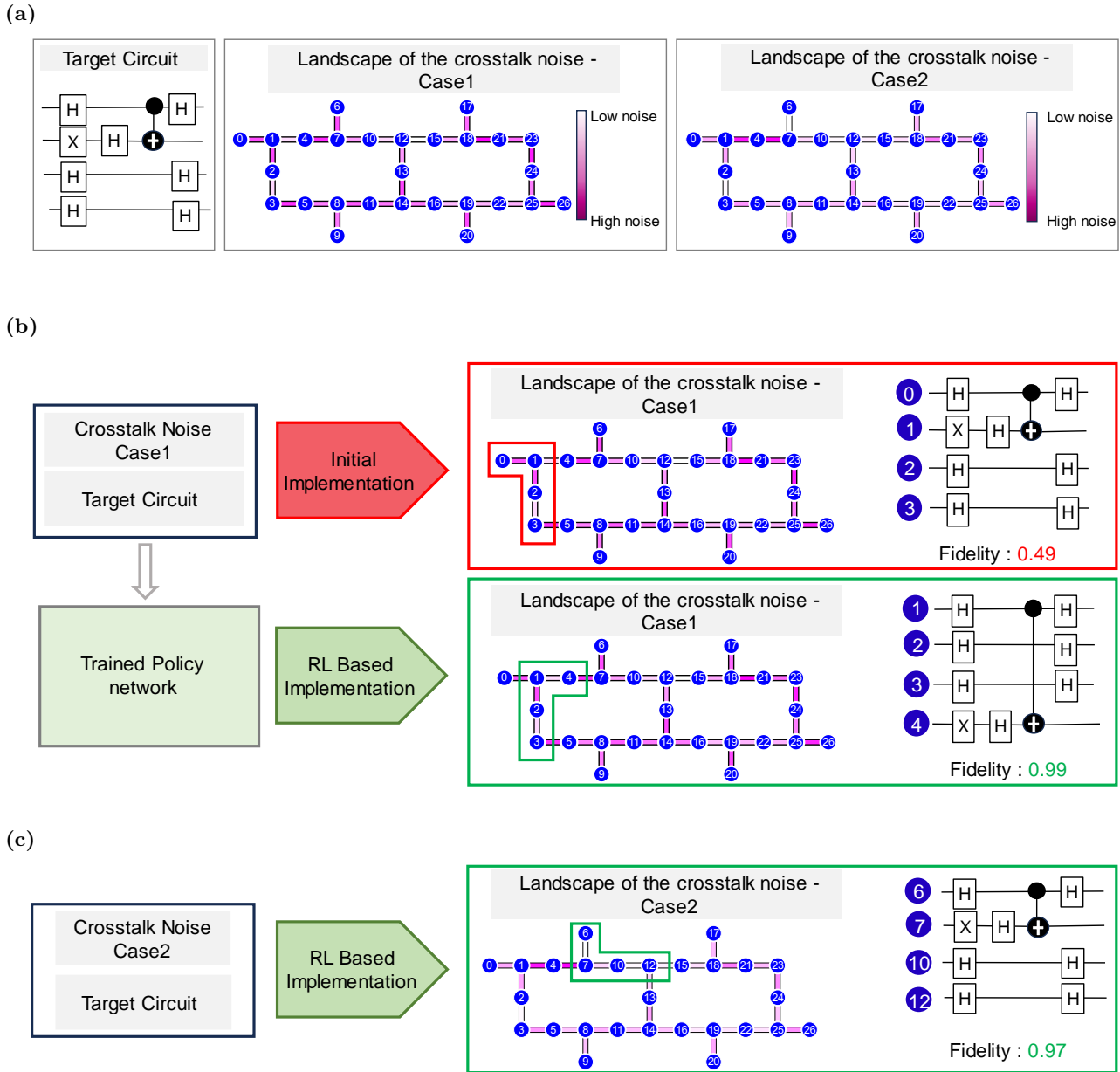

FIG. 5. Comparison of circuit mapping strategies in the presence of two different noise landscapes. (a) Displays the target circuit with two noise scenarios, Case1 depicting an intrinsic noise landscape and Case2 an altered noise profile. (b) A target circuit is introduced, and an initial mapping shows poor fidelity. In contrast, utilizing the reinforcement learning (RL) method, the circuit is strategically placed on the device, causing a significantly improved fidelity. (c) Demonstrates RL’s robustness in achieving optimal fidelity despite varied noise conditions in Case 2.

conditions. FIG. 5(a) presents the target circuit for implementation on a physical quantum computer. The study employs two distinct noise scenarios: Case1 is the intrinsic noise environment of an IBM quantum computer, while Case2 introduces an intentionally modified noise framework, where the noise between qubits 1 and 4 is intentionally increased. This modification was designed to test the robustness of our RL model.

Here, the fidelity is the probability of the circuit producing the correct output. In contrast to the initial map-

ping, which causes low fidelity, the RL-based strategy in FIG. 5(b) demonstrates a significant improvement in fidelity. The improvement in fidelity is achieved through the RL algorithm’s strategic circuit placement, enhancing overall performance. FIG. 5(c) further investigates the resilience of the RL method by introducing an artificial variation in the noise landscape, represented by Case2 in FIG. 5(a). Despite the altered conditions, the RL method consistently maintains high fidelity. This consistency underscores the method’s adaptability to the noise.

Algorithm 1 Reinforcement training loop

```

Policy Network  $\leftarrow$  initial
for circuit  $\in$  training data do
  for mapping  $\in$  actions do
    mapped circuit  $\leftarrow$  mapping(circuit)
    fidelity  $\leftarrow$  reward(mapped circuit)
    Policy Network  $\leftarrow$  update(Policy network, fidelity)
  end for
end for

```

C. Crosstalk Attack detection via a Spectator Qubit

The use of Spectator Qubit (SQ) in quantum control is a novel idea that has been studied theoretically [20, 21] and experimentally [22]. A SQ refers to a qubit that coexists inside the same physical space as a data qubit (DQ). The SQ should be positioned in close proximity to the data qubit in order to effectively capture the same noise. However, it should also be positioned at a sufficient distance to avoid any potential interaction with the data qubit. The objective is to perform frequent measurements on the SQ in order to gain knowledge about the effect of noise on the data qubits. Subsequently, equipped with the acquired knowledge, we have the choice of correcting the imprecision in the data qubit to a certain degree or declaring that the data qubit has been considerably affected, resulting in the loss of its quantum information. Despite recent research on the SQ idea, its direct use on quantum computing devices has not been demonstrated. The main obstacle to implementing SQ on quantum computing devices is the lack of multiple measurements, resets, and feedback loops inside a running circuit in current devices. Instead, we use the results of the IBM quantum device characterization from Sec. II to replicate the SQ notion for detecting the presence of nearby crosstalk attacks.

1. Dynamical correlation between the spectator and the data qubits

The key assumption underlying the SQ concept is that SQ and DQ exhibit correlated dynamics when subjected to noise. In previous studies on SQ, this correlation has been artificially introduced either by choosing a similar Hamiltonian for both SQ and DQ in theoretical studies [20, 21] or by using engineered noise in an experimental setting [22].

In contrast, we intend to implement the SQ concept on an IBM device without engineering any noise or Hamiltonian. Thus, in the first stage, we analyse the correlated dynamics of two qubits, one as the DQ and one as the SQ, under the influence of a crosstalk attack. To accomplish this, we simulate the dynamics of the SQ and DQ for various settings on the 27-qubit IBMQ using the crosstalk

noise model characterised from the real 27-qubit device described in Sec. II.

FIG. 6(a) shows an example of the aforementioned simulation. Here, we choose qubits 11 and 14 as the DQ and the SQ respectively, as depicted by the solid green (red) square for DQ (SQ) on the topology of the device. Also, we choose qubits 12 and 13 as attack qubits (AQ) depicted via dash black squared on the topology. Furthermore, the quantum circuit in FIG. 6(a) shows our approach to simulating the dynamics of the SQ and DQ under the effect of a crosstalk attack. At time $t = t_0$, we initialize the DQ in $|+\rangle = (|0\rangle + |1\rangle)/\sqrt{2}$ via a Hadamard gate and leave the SQ in $|0\rangle$ state. We then apply a series of CNOT gates on AQ.

Our simulation confirms the correlated dynamics of the SQ and DQ. In FIG. 6(a), we demonstrate this correlated dynamics by picturing the state of the DQ and SQ at different times via Bloch sphere. The top row shows the state of DQ at different times, while the bottom row shows the state of SQ. The states of the SQ and the DQ at $t = t_0$ are $|0\rangle$ and $|+\rangle$ respectively, as expected. As time passes, at t_1, t_2 , and t_3 , we observe that the states of both SQ and DQ rotate in the same direction (the rotation trajectories are shown by points). The synchronised rotations are caused by the crosstalk attack which confirms that SQ and DQ's dynamics are correlated.

We emphasise here that this correlated dynamics is simulated using the data from the characterization of the real IBM device (see Section II), which represents the crosstalk effect in the real device and is not engineered correlated noise.

2. Measurement Strategy for the Spectator Qubit

We showed the correlated dynamics of SQ and DQ. The idea is to gather information about noise by measuring the SQ. However, measuring the spectator qubit causes its state to be projected to either $|0\rangle$ or $|1\rangle$, so it might not be a useful SQ after a measurement. To overcome this, following a similar setup as in [20], we repeatedly measure the SQ, record the result, and reset the SQ to $|0\rangle$ state; we then repeat the measurement/reset process many times. The challenge is to find out how frequently we must measure and reset the SQ. If we measure the SQ often, it will not have enough time to be impacted by the crosstalk attack; if we wait too long before measuring the SQ, its state may rotate back to its initial value or be influenced by other noise rather than the crosstalk that we are interested in.

To address the above question, we consider a scenario where we would like to detect the presence of a crosstalk attack. We use a similar setup as before, i.e., qubit 14 as SQ and qubits 12 and 13 as AQ (note that we do not need DQ in this scenario). The goal is to identify if a crosstalk attack is present by measuring the SQ. To do that, we measure the SQ repeatedly and reset it after each measurement. In the absence of crosstalk, the spec-

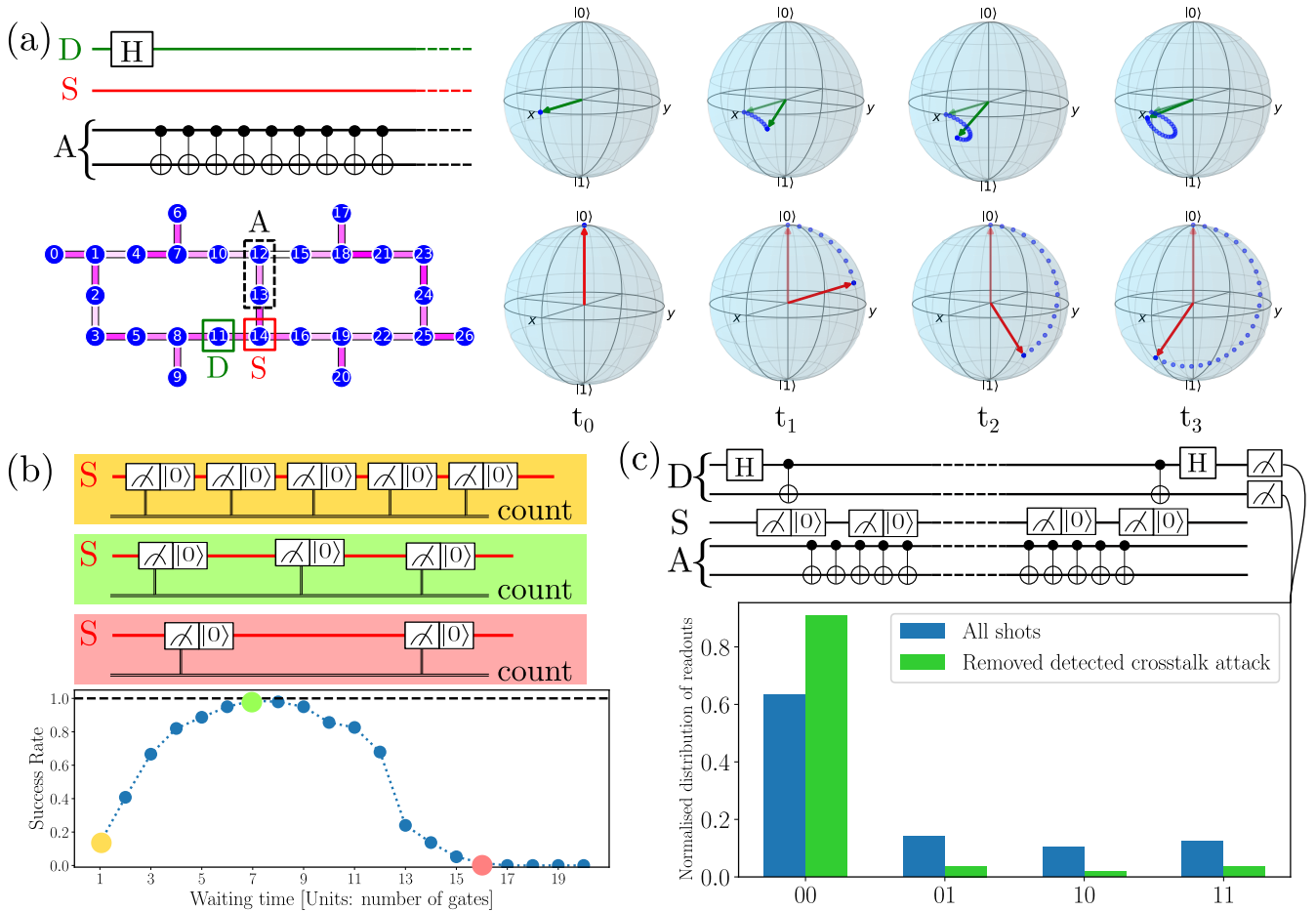

FIG. 6. (a) Demonstration of correlated dynamics of data qubit and spectator qubit under the effect of crosstalk attack. Here, qubit 11 of the IBM device, is chosen as data qubit and initialised at $|+\rangle$ using a Hadamard gate. Qubit 14 plays the role of the spectator and its initial state is $|0\rangle$. Crosstalk attack is performed via a series of CNOT gates on qubits 12 and 13. Bloch spheres of data qubit (top row) and spectator qubit (bottom row) at different times demonstrate the correlated dynamics between the spectator and the data qubit. (b) Schematic for finding the optimum waiting time to detect the presence of the crosstalk attack. If the waiting time is chosen to be too short or too long, the spectator qubit would not detect the presence of the crosstalk attack. (c) By removing shots with detected crosstalk we mitigate the effect of the crosstalk.

tator qubit stays at state $|0\rangle$ so the measurement result would always be ‘0’. Thus, if the measurement results in ‘1’, it would be a *flag* for the presence of an attack. To continue, we count the number of flags and store them in f ; then, if the number of flags is greater than a predefined threshold f_0 , we indicate that the shot was under attack. Note that, in an ideal simulation where the noise is due to only crosstalk attacks, $f_0 = 0$, but if we consider other possible noise, especially measurement noise, we may consider $f_0 > 0$ to be more relaxed in deciding the presence of an attack.

Furthermore, we run N shots of the setup (all shots are under attack) and we define a success rate $\eta = N_d/N$ where N_d is number of detected shots under attack. We repeat the procedure for different waiting time and calculate the success rate η for each waiting time to find the optimum waiting time. In our simulation we

use $N = 1000$ shots and waiting time defined in units of number of CNOT gates. In FIG. 6(b), we illustrated three highlighted scenarios: measuring the SQ too frequently (orange), optimal waiting time (green) and long waiting time (red). Moreover, the plot shows our simulation result. As we expected, if we measure the spectator qubit after only one gate, its state has not evolved enough to detect the attack. On the other hand, if we wait too long, we see the state rotates back to $|0\rangle$ and we get low success rate. Our simulation shows that optimum waiting time for our setup is approximately 7 CNOT gates.

3. Detection of the crosstalk attack

Now that we have a protocol to detect the presence of a crosstalk attack, we can use it to post-select our shots. To demonstrate this idea, we simulate the following scenario: Consider two data qubits initialized in an entangled state, which after some time we would like to use. Also, consider that some but not all of the shots are under crosstalk attack. Although we do not know which shots are under attack, we use the spectator qubit to detect the impacted shots and discard them, i.e., post select on the shots that are not under attack. In our simulation, at the end of the circuit, we disentangle the qubits before measurement, so the measurement result of the data qubits should be 00. Also, in the simulation, we choose that 20% of the shots are under crosstalk attack. This percentage is arbitrary, but because we are discarding the attacked shots, we choose a relatively small percentage (below 50%). FIG. 6(c) shows our circuit as well as the normalized histogram of the final count of the data qubits. Blue represents all shots, while green shows the post-selected shots. From the histogram, it is obvious we have successfully discarded many of the impacted shots.

Although we successfully flagged the presence of the attack, discarding the shots is wasteful. Correcting the impacted shots using the SQ has been done in [20, 21] for dephasing noise. Correcting the qubit state that is impacted by a crosstalk attack is more complicated, and we leave it for our future work. Also, we did not consider the crosstalk effect of SQ measurement/reset on DQ. Because this method is not now available on IBM devices, incorporating it into our model would be a future work. Moreover, for a larger circuit, we probably need more than one spectator qubit. So, optimizing the multi-spectator qubit is another objective for future work.

IV. CONCLUSION AND DISCUSSION

Crosstalk noise is a serious issue for near term and future large scale quantum devices. In this paper we have demonstrated the adverse effects of crosstalk on a circuit, particularly in a device shared by many users. We developed a full map of the crosstalk on a real IBM device, and used this to create a high fidelity simulator for the device.

We then developed a number of techniques to detect and/or mitigate the effects of a hostile crosstalk attack on a shared device. The first technique, circuits separation, was effective, but sees a substantial amount of the device left to idle, while scaling poorly to devices with large numbers of qubits. We then developed a reinforcement learning model to learn the noise on the device, and placed circuits in such a way that minimises the potential for crosstalk interference on the device. The final technique was based on the idea of spectator qubits, which have already been used for detecting and mitigating general noise models. We applied the spectator qubit

technique to the problem of crosstalk noise, and found that it was highly effective at detecting the presence of a crosstalk attack. Further work on the spectator qubit technique includes correcting for a crosstalk induced error, rather than simply discarding erroneous shots. It is also necessary to further explore the optimal placement of spectator qubits around a circuit.

The crosstalk attacks studied here, and elsewhere in the literature, are simple repeated CNOTs, designed to maximise the disrupting effect of crosstalk. It may be possible to create an attack which disrupts a computation in a targeted way, for example, by causing Grover's algorithm to select an incorrect answer with high confidence. Future work can explore such possibility and develop methods to detect and mitigate such scenarios.

There is the potential to flip the crosstalk attacks — and instead use crosstalk to extract information. Quantum algorithms require classical data, which may be sensitive. This data is encoded in state preparation circuits, and a third party may be able to derive some knowledge of the secret data through exploiting crosstalk. While challenging, the potential impact of this could be significant, justifying further work.

Finally, the crosstalk benchmarking described here can be applied to a variety of hardware architectures, such as silicon qubits, trapped ions, or others. These are very different physical systems, which will have very different properties. It is important to properly explore the effect of crosstalk on other hardware, to see how bad (or not) it is. In summary, we have laid the foundation to exploit crosstalk noise as a mechanism to attack and disrupt quantum computations in a shared environment. We have also reported mitigation strategies and demonstrated their working on proof of concept examples. In near to medium term era when quantum computing is anticipated to be based on shared environment through cloud platforms, securing it will be of paramount importance in particular for security sensitive data and computations.

ACKNOWLEDGMENT

BH acknowledges the support of the CSIRO Research Training Program Scholarship. The work was partially supported by the Australian Army through Quantum Technology Challenge 2023. The computational resources were provided by the National Computing Infrastructure (NCI) and Pawsey Supercomputing Center through National Computational Merit Allocation Scheme (NCMAS). The research was supported by the University of Melbourne through the establishment of the IBM Quantum Network Hub at the University.

Data availability: The data that support the findings of this study are available within the article.

Competing financial interests: The authors declare no competing financial or non-financial interests.

-
- [1] D. Suter and G. A. Álvarez, *Rev. Mod. Phys.* **88**, 041001 (2016).
- [2] A. A. Clerk, M. H. Devoret, S. M. Girvin, F. Marquardt, and R. J. Schoelkopf, *Rev. Mod. Phys.* **82**, 1155 (2010).
- [3] M. Sarovar, T. Proctor, K. Rudinger, K. Young, E. Nielsen, and R. Blume-Kohout, *Quantum* **4**, 10.22331/Q-2020-09-11-321 (2020).
- [4] G. White, K. Modi, and C. Hill, *Physical Review Letters* **130**, 160401 (2023).
- [5] E. Magesan and J. M. Gambetta, *Phys. Rev. A* **101**, 052308 (2020).
- [6] Y. Sung, L. Ding, J. Braumüller, A. Vepsäläinen, B. Kannan, M. Kjaergaard, A. Greene, G. O. Samach, C. McNally, D. Kim, A. Melville, B. M. Niedzielski, M. E. Schwartz, J. L. Yoder, T. P. Orlando, S. Gustavsson, and W. D. Oliver, *Phys. Rev. X* **11**, 021058 (2021).
- [7] F. Mazda, *Telecommunications engineer’s reference book* (Butterworth-Heinemann, 2014) p. xi.
- [8] C. Fang, Y. Wang, S. Huang, K. R. Brown, and J. Kim, *Physical Review Letters* **129**, 240504 (2022).
- [9] Z. Zhou, R. Sitler, Y. Oda, K. Schultz, and G. Quiroz, *Phys. Rev. Lett.* **131**, 210802 (2023).
- [10] P. Parrado-Rodríguez, C. Ryan-Anderson, A. Bermudez, and M. Müller, *Quantum* **5**, 487 (2021).
- [11] D. Buterakos, R. E. Throckmorton, and S. Das Sarma, *Phys. Rev. B* **97**, 045431 (2018).
- [12] A. A. Saki, M. Alam, K. Phalak, A. Suresh, R. O. Topaloglu, and S. Ghosh, *A Survey and Tutorial on Security and Resilience of Quantum Computing* (2021), arXiv:2106.06081 [quant-ph].
- [13] R. J. Blume-Kohout, *Idle Tomography.*, Tech. Rep. SAND2019-0010PE (Sandia National Lab. (SNL-NM), Albuquerque, NM (United States), 2019).
- [14] Erik and Kmrudin, *pyGSTi: Version 0.9.1 Alpha* (2016).
- [15] A. Ash-Saki, M. Alam, and S. Ghosh, *IEEE Transactions on Quantum Engineering* **1**, 1 (2020), conference Name: IEEE Transactions on Quantum Engineering.
- [16] Y. Ohkura, T. Satoh, and R. Van Meter, *IEEE Transactions on Quantum Engineering* **3**, 1 (2022), conference Name: IEEE Transactions on Quantum Engineering.
- [17] N. Quetschlich, L. Burgholzer, and R. Wille, in *2023 60th ACM/IEEE Design Automation Conference (DAC)* (IEEE, 2023) pp. 1–6.
- [18] Y. Baum, M. Amico, S. Howell, M. Hush, M. Liuzzi, P. Mundada, T. Merkh, A. R. Carvalho, and M. J. Biercuk, *PRX Quantum* **2**, 040324 (2021).
- [19] H. P. Nautrup, N. Delfosse, V. Dunjko, H. J. Briegel, and N. Friis, *Quantum* **3**, 215 (2019).
- [20] B. Tonekaboni, A. Chantasri, H. Song, Y. Liu, and H. M. Wiseman, *Phys. Rev. A* **107**, 032401 (2023).
- [21] H. Song, A. Chantasri, B. Tonekaboni, and H. M. Wiseman, *Phys. Rev. A* **107**, L030601 (2023).
- [22] K. Singh, C. Bradley, S. Anand, V. Ramesh, R. White, and H. Bernien, *Science* **380**, 1265 (2023).

Appendix A: Total Variational Distance

For two probability distributions, P, Q over the same space of outcomes Ω , the Total Variational Distance (TVD) is the maximum difference between the distributions over all events,

$$\text{TVD}(P, Q) = \sup_{E \in \Omega} |P(E) - Q(E)| \quad (\text{A1})$$

The TVD measures a distance between two distributions — so when comparing the output fidelities of various simulators, a reference distribution is required. Previous work benchmarking the performance of a crosstalk simulator [15] has chosen to use an ideal noise-free simulation as the reference distribution, with the crosstalk simulator and real device measured relative to this. However, this may be misleading, as the real device and the crosstalk simulator may be a similar distance away from an ideal simulation, but not close to each other at all. As such, in this paper we use the real device probability distribution as reference, and so a better simulation of that real device has a lower TVD. For a circuit with real counts c_d , and simulated counts c_s , we find that the distance is,

$$\text{dist}(c_s) = \text{TVD}(c_s, c_d) \quad (\text{A2})$$

Appendix B: Benchmarking Circuits

Below are circuit diagrams for the circuits used in benchmarking the crosstalk simulator used in section II B.

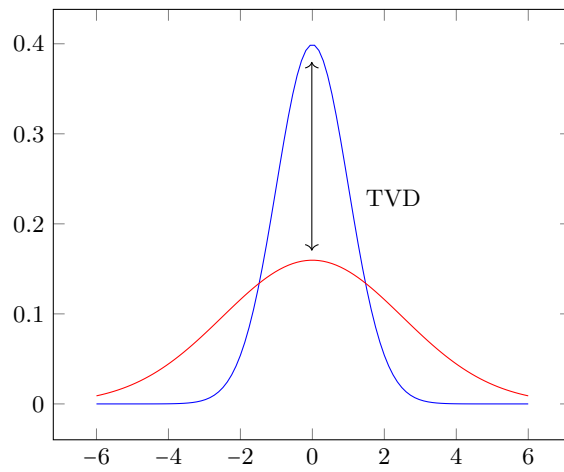
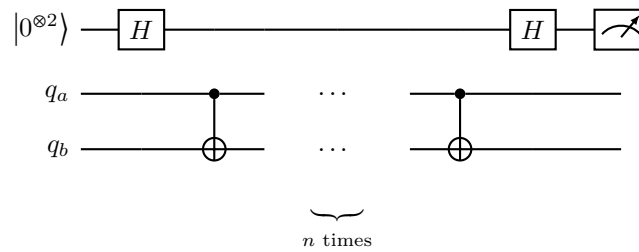

FIG. 7. The total variational distance is the greatest distance between two probability distributions.

1. syn_n

This is a synthetic circuit where two idle qubits are prepared into a superposition.



The CNOT gate is repeated n times.

2. toffoli

This is a simple repeated Toffoli gate test. The Toffoli gates are decomposed into 1-qubit gates and the 2-qubit CNOT gate.

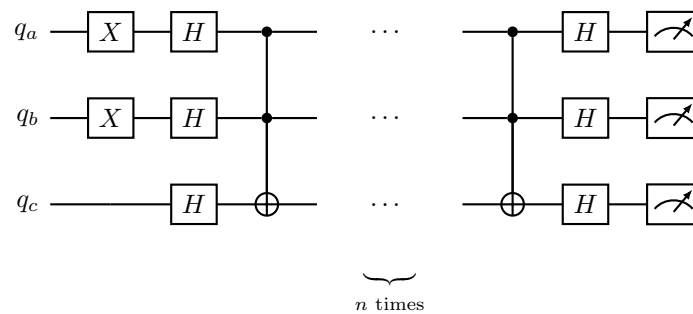

The Toffoli gate is repeated n times.

3. grover

The grover circuit is a simple 3-qubit Grover's algorithm circuit with two iterations.

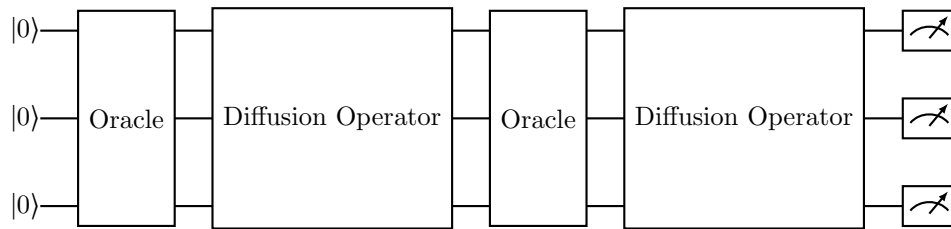

4. attack

The attack test circuit is identical to the Grover's algorithm circuit, with the addition of a crosstalk attack on adjacent qubits;

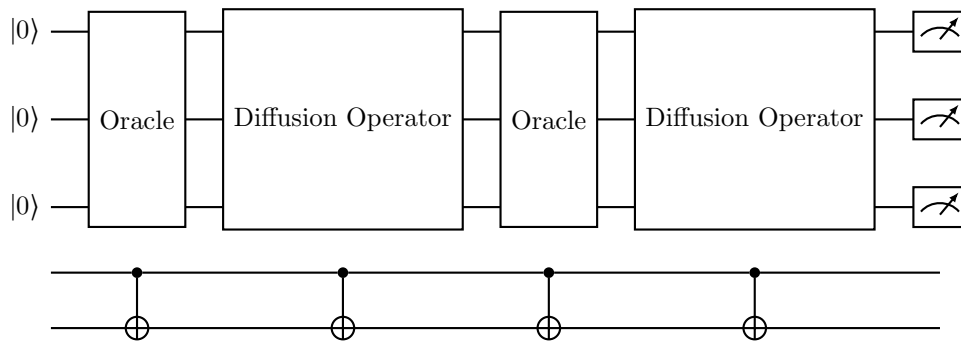

CNOT gates are repeated during the execution of the circuit.