

Sender-controlled measurement-device-independent multiparty quantum communication

Yuyan Wei¹, Siying Wang¹, Yajing Zhu¹, and Tao Li^{1,2*}

¹ *School of Science, Nanjing University of Science and Technology, Nanjing 210094, China*

² *MIIT Key Laboratory of Semiconductor Microstructure, Nanjing University of Science and Technology, Nanjing 210094, China*

(Dated: February 22, 2022)

Multiparty quantum communication is an important branch of quantum networks. It enables private information transmission with information-theoretic security among legitimate parties. We propose a sender-controlled measurement-device-independent multiparty quantum communication protocol. The sender Alice divides a private message into several parts and delivers them to different receivers for secret sharing with imperfect measurement devices and untrusted ancillary nodes. Furthermore, Alice acts as an active controller and checks the security of quantum channels and the reliability of each receiver before she encodes her private message for secret sharing, which makes the protocol convenient for multiparty quantum communication.

I. INTRODUCTION

Quantum communication, such as quantum key distribution (QKD) [1–5], quantum secure direct communication (QSDC) [6–14], and quantum secret sharing (QSS) [15–19], provides an absolutely secure technique that transmits private information between legitimate parties. Bennett and Brassard proposed the first quantum communication protocol [20], enabling two parties to share private key for encryption. In principle, eavesdroppers attacking on a quantum communication process introduce perturbations that inevitably reveal their interception [1]. However, practical apparatuses with imperfect functions may have loopholes for side-channel attacks on quantum cryptography [21–23]. In principle, the device independent architecture based on the violation of Bell inequality can remove all side-channel attacks on quantum cryptography using non-ideal devices [24–26], whereas it requires a loophole-free Bell test [22]. Measurement-device-independent (MDI) architecture [27] provides a simplified strategy for removing serious side-channel attacks on practical measurement apparatuses by using postselected entanglement. For instance, two legitimate parties with practical measurement apparatuses can share private key by MDI-QKD [21, 22] and directly exchange classical messages over quantum channels by MDI-QSDC [28–31].

Multiparty quantum communication involves more than two nodes of a network and directly transmits private information among them without any classical relay [32–34]. QSS is a typical multiparty quantum communication protocol [15–19]. It splits a private message into several parts and sends each part to one party; the message can only be reconstructed through cooperation between all parties. In 1999, Hillery, Bužek and Berthiaume [15] proposed the first QSS protocol us-

ing a maximally entangled three-particle Greenberger-Horne-Zeilinger (GHZ) state; Karlsson et al. [35] proposed a QSS protocol using two-particle quantum entanglement. In 2004, Xiao et al. [36] proposed a high-efficient QSS protocol, increasing its efficiency to asymptotically 100% by properly choosing measurement bases [37, 38]. Subsequently, some interesting QSS protocols were proposed [39–46].

In 2015, Fu et al. [47] proposed the first MDI-QSS protocol with postselected GHZ states and closed loopholes introduced by practical measurement apparatuses. Recently, Gao et al. [48] presented a deterministic MDI-QSS (DMDI-QSS) protocol and removed the requirement of basis reconciliation in the MDI architecture [21–23]. In this protocol, the sender Alice produces entangled photon pairs and sends one photon from each pair to David, whereas the receivers (Bob and Charlie) randomly produce single photons in an eigenstate of σ_X or σ_Y basis, and also send their photons to David for GHZ-state analysis. The GHZ-state analyzer in David's node [49–51], in principle, performs a teleportation operation and correlates the states of photons kept in Alice's node to that prepared by the receivers. The receivers check the security of DMDI-QSS before information encoding; and some of receivers can cheat one receiver by a particular strategy [52–54]. Therefore, it requires at least two faithful receivers to guarantee the security of DMDI-QSS against the participant attack [48].

Here we present a sender-controlled MDI-QSS protocol, in which the sender performs as an active controller [55] and can detect the attack from either outside eavesdropper or unfaithful receiver (i.e., participant attack) by cooperating with receivers. Single photons with random polarization inserted into entangled photon pairs are used for security check [28–30]. Once a postselected GHZ state is produced by ancillary David from individual single photons, exclusive correlations are created among photon states prearranged by the sender and receivers. After receiving the photon states published by all receivers, the sender can perform security check based on

*tao.li@njjust.edu.cn

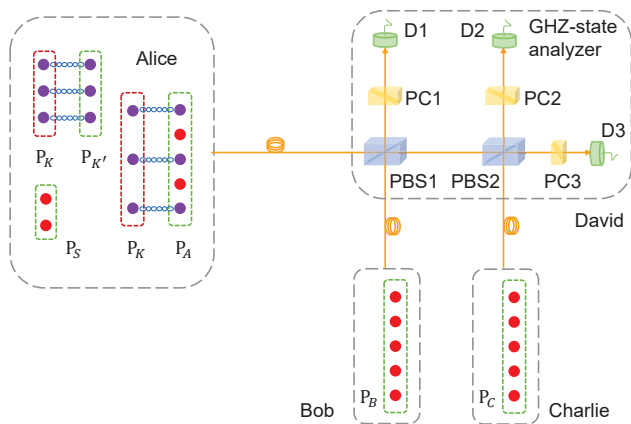

FIG. 1: Schematic diagram of sender-controlled MDI-QSS protocol. PBS1 and PBS2 are two polarizing beam splitters that transmit photons with horizontal polarization $|0\rangle$ and reflect photons with vertical polarization $|1\rangle$; PC is a polarization controller and completes a $\pi/4$ rotation of the polarization; D1, D2, and D3 are single-photon detectors, which can distinguish between two polarizations $|0\rangle$ and $|1\rangle$.

the postselected multiphoton entanglement rather than the multiphoton quantum teleportation that requires ancillary measurements [48]. Therefore, the sender acts as an active controller and encodes private information after ascertaining the security of quantum channels and the reliability of each receiver, which enables the receivers to share private messages over quantum channels and makes this protocol convenient for practical secret sharing.

II. THREE-PARTY SENDER-CONTROLLED MDI-QSS PROTOCOL

A sender-controlled MDI-QSS protocol among three legitimate parties is shown in Fig. 1. The sender Alice prepares a sequence of entangled photon pairs and divides them into two sequences. She sends one photon sequence to ancillary David after she randomly inserts some single photons with random polarization in it. Bob and Charlie prepare single photons with random polarization and send them to David as well. David performs GHZ-state analysis of each three photons with the same order and heralds exclusive correlations among three legitimate parties by either postselected entanglement generation or quantum teleportation. These two cases will be used for security check and secret splitting, respectively. Specifically, the three-party sender-controlled MDI-QSS proposal is carried out in the following steps.

Step (1) Photon-sequence preparation. Alice prepares k_1 entangled photon pairs in the Bell state $|\varphi^-\rangle = (|01\rangle - |10\rangle)/\sqrt{2}$, where $|0\rangle$ ($|1\rangle$) represents a horizontally (vertically) polarized photon, and divides them into two sequences P_K and $P_{K'}$ by choosing one photon from each pair and rearranging them with the same order as in photon pair sequence [6–8]. She also prepares a sequence

P_S consisting of k_2 single photons which are randomly prepared in either σ_X [i.e., $|\pm x\rangle = (|0\rangle \pm |1\rangle)/\sqrt{2}$] or σ_Y [i.e., $|\pm y\rangle = (|0\rangle \pm i|1\rangle)/\sqrt{2}$] basis, and randomly inserts them into $P_{K'}$ to reform a new sequence P_A consisting of $n = k_1 + k_2$ photons. Meanwhile, Bob and Charlie prepare n -photon sequences P_B and P_C with each photon randomly initialized in either σ_X or σ_Y basis, respectively.

Step (2) Photon-sequence transmission. Alice, Bob, and Charlie send their photon sequences P_A , P_B , and P_C to the untrusted ancillary David to perform a GHZ-state analysis of each three photons with the same order. The GHZ-state analyzer can project the incoming photons into one of three-photon GHZ states that can be described as

$$\begin{aligned} |\Phi\rangle_{000} &= \frac{1}{\sqrt{2}}(|000\rangle + |111\rangle), & |\Phi\rangle_{001} &= \frac{1}{\sqrt{2}}(|000\rangle - |111\rangle), \\ |\Phi\rangle_{010} &= \frac{1}{\sqrt{2}}(|001\rangle + |110\rangle), & |\Phi\rangle_{011} &= \frac{1}{\sqrt{2}}(|001\rangle - |110\rangle), \\ |\Phi\rangle_{100} &= \frac{1}{\sqrt{2}}(|010\rangle + |101\rangle), & |\Phi\rangle_{101} &= \frac{1}{\sqrt{2}}(|010\rangle - |101\rangle), \\ |\Phi\rangle_{110} &= \frac{1}{\sqrt{2}}(|011\rangle + |100\rangle), & |\Phi\rangle_{111} &= \frac{1}{\sqrt{2}}(|011\rangle - |100\rangle). \end{aligned} \quad (1)$$

In practice, a GHZ-state analyzer can only identify two GHZ states $|\Phi\rangle_{000}$ and $|\Phi\rangle_{001}$ when using linear optical elements and single-photon detectors [49–51], shown in Fig. 1. PBS1 and PBS2 are two polarizing beam splitters that transmit photons with horizontal polarization $|0\rangle$ and reflect photons with vertical polarization $|1\rangle$; PC is a polarization controller and completes a $\pi/4$ rotation of the polarization; D1, D2, and D3 are single-photon detectors and can distinguish between two polarizations $|0\rangle$ and $|1\rangle$, reporting 0 and 1, respectively. Therefore, the state $|\Phi\rangle_{000}$ leads to a coincidence event of three-detector clicks 000, 011, 101, or 110, while the state $|\Phi\rangle_{001}$ results in an event 001, 010, 100, or 111 [50]. Although the success probability of this analysis is 1/4, it is enough for security check and secret sharing of our three-party sender-controlled MDI-QSS protocol.

When a photon k' of sequence P_A entering the GHZ-state analyzer originates from $P_{K'}$ and entangles with the photon k of sequence P_K , the GHZ-state analysis can correlate the state of photon k kept in Alice's node and the single-photon states $|i\rangle$ and $|j\rangle$ prepared by Bob and Charlie with $i, j \in \{+x, -x, +y, -y\}$. In general, the states of photons k kept in Alice's node will be projected into an eigenstate of σ_X (σ_Y) if Bob and Charlie prepare their photons in basis $\sigma_X \otimes \sigma_Y$ or $\sigma_Y \otimes \sigma_X$ ($\sigma_X \otimes \sigma_X$ or $\sigma_Y \otimes \sigma_Y$) [48] and David reports successful GHZ-state measurements on photons sent to him, shown in Tables I and II. α is the number of σ_Y basis that Bob and Charlie use for single-photon preparation. β is the number of states $| -x\rangle$ and $| -y\rangle$ that Bob and Charlie prepared. $\gamma_j \leq \text{Min}\{\alpha, 1\}$ is the number of state $|1\rangle$ of photons that are prepared in the σ_Y basis in each $|\omega\rangle_j$. Here $|\omega\rangle_j$

with $j = 1, 2, 3, 4$ are four state vectors of the $\sigma_Z \otimes \sigma_Z$ basis, the superposition of which consists the two-photon state $|i\rangle \otimes |j\rangle$. For instance, David announces a GHZ state $|\Phi\rangle_{000}$, Bob and Charlie prepare their photons in the state $|+x\rangle \otimes |+x\rangle$, this corresponds to the Case 1 in Table I ($\alpha = 0, \beta = 0$) with $\gamma_j = 0$ and $\alpha - 2\gamma_j = 0$, and the corresponding photon in sequence P_K is projected into the state $|-x\rangle$; David announces a GHZ state $|\Phi\rangle_{001}$, Bob and Charlie prepare their photons in the state $|+x\rangle \otimes |-y\rangle$, this corresponds to the Case 4 in Table II ($\alpha = 1, \beta = 1$) with $\gamma_j = 0$ ($\gamma_j = 1$) and $\alpha - 2\gamma_j = 1$ ($\alpha - 2\gamma_j = -1$), and the corresponding photon in sequence P_K is projected into the state $|+y\rangle$ ($|-y\rangle$). Alice can encode her information by applying local operations on photons kept in her node, and then sends them to receivers for secret sharing.

When a photon s of sequence P_A entering the GHZ-state analyzer originates from P_S , it is separable from all other photons. The product state of three photons entering GHZ-state analyzer can be described as a superposition of three-photon GHZ states. The GHZ-state analyzer can only report one GHZ state of the superposition each time, referred to as postselected entanglement. In general, when Alice, Bob, and Charlie prepare their photons in the bases with even σ_Y , such as $\sigma_X \otimes \sigma_X \otimes \sigma_X$, $\sigma_X \otimes \sigma_Y \otimes \sigma_Y$, $\sigma_Y \otimes \sigma_X \otimes \sigma_Y$, $\sigma_Y \otimes \sigma_Y \otimes \sigma_X$, any three-photon product state will be a superposition of four GHZ states, whereas it never simultaneously contains states $|\Phi\rangle_{b_1 b_2 0}$ and $|\Phi\rangle_{b_1 b_2 1}$ with relative phase differences 0 and π between two components consisting them, respectively. Here the subscripts $b_1, b_2 \in \{0, 1\}$ of $|\Phi\rangle_{b_1 b_2 0}$ are identical to that of $|\Phi\rangle_{b_1 b_2 1}$. For instance, when Alice, Bob, and Charlie prepare their single photons in $\sigma_X \otimes \sigma_X \otimes \sigma_X$ basis, eight three-photon product states can be described in the GHZ-state basis as follows:

$$\begin{aligned}
|+x+x+x\rangle &= \frac{1}{2}(|\Phi\rangle_{000} + |\Phi\rangle_{010} + |\Phi\rangle_{100} + |\Phi\rangle_{110}), \\
|+x+x-x\rangle &= \frac{1}{2}(|\Phi\rangle_{001} - |\Phi\rangle_{011} + |\Phi\rangle_{101} - |\Phi\rangle_{111}), \\
|+x-x+x\rangle &= \frac{1}{2}(|\Phi\rangle_{001} + |\Phi\rangle_{011} - |\Phi\rangle_{101} - |\Phi\rangle_{111}), \\
|-x+x+x\rangle &= \frac{1}{2}(|\Phi\rangle_{001} + |\Phi\rangle_{011} + |\Phi\rangle_{101} + |\Phi\rangle_{111}), \\
|+x-x-x\rangle &= \frac{1}{2}(|\Phi\rangle_{000} - |\Phi\rangle_{010} - |\Phi\rangle_{100} + |\Phi\rangle_{110}), \\
|-x+x-x\rangle &= \frac{1}{2}(|\Phi\rangle_{000} - |\Phi\rangle_{010} + |\Phi\rangle_{100} - |\Phi\rangle_{110}), \\
|-x-x+x\rangle &= \frac{1}{2}(|\Phi\rangle_{000} + |\Phi\rangle_{010} - |\Phi\rangle_{100} - |\Phi\rangle_{110}), \\
|-x-x-x\rangle &= \frac{1}{2}(|\Phi\rangle_{001} - |\Phi\rangle_{011} - |\Phi\rangle_{101} + |\Phi\rangle_{111}).
\end{aligned} \tag{2}$$

When Alice, Bob, and Charlie prepare their photons in the basis $\sigma_X \otimes \sigma_Y \otimes \sigma_Y$, any three-photon product state will be referred to as a superposition of four GHZ states

similar to the aforementioned case as follows:

$$\begin{aligned}
|+x+y+y\rangle &= \frac{1}{2}(|\Phi\rangle_{001} + i|\Phi\rangle_{010} + i|\Phi\rangle_{100} - |\Phi\rangle_{111}), \\
|+x+y-y\rangle &= \frac{1}{2}(|\Phi\rangle_{000} - i|\Phi\rangle_{011} + i|\Phi\rangle_{101} + |\Phi\rangle_{110}), \\
|+x-y+y\rangle &= \frac{1}{2}(|\Phi\rangle_{000} + i|\Phi\rangle_{011} - i|\Phi\rangle_{101} + |\Phi\rangle_{110}), \\
|-x+y+y\rangle &= \frac{1}{2}(|\Phi\rangle_{000} + i|\Phi\rangle_{011} + i|\Phi\rangle_{101} - |\Phi\rangle_{110}), \\
|+x-y-y\rangle &= \frac{1}{2}(|\Phi\rangle_{001} - i|\Phi\rangle_{010} - i|\Phi\rangle_{100} - |\Phi\rangle_{111}), \\
|-x+y-y\rangle &= \frac{1}{2}(|\Phi\rangle_{001} - i|\Phi\rangle_{010} + i|\Phi\rangle_{100} + |\Phi\rangle_{111}), \\
|-x-y+y\rangle &= \frac{1}{2}(|\Phi\rangle_{001} + i|\Phi\rangle_{010} - i|\Phi\rangle_{100} + |\Phi\rangle_{111}), \\
|-x-y-y\rangle &= \frac{1}{2}(|\Phi\rangle_{000} - i|\Phi\rangle_{011} - i|\Phi\rangle_{101} - |\Phi\rangle_{110}),
\end{aligned} \tag{3}$$

Similarly, when Alice, Bob, and Charlie prepare their photons in the basis $\sigma_Y \otimes \sigma_X \otimes \sigma_Y$ or $\sigma_Y \otimes \sigma_Y \otimes \sigma_X$, any three-photon product state will also be referred to as a superposition of four GHZ states. For these two cases, any three-photon product state can be, respectively, described as

$$\begin{aligned}
|+y+x+y\rangle &= \frac{1}{2}(|\Phi\rangle_{001} + i|\Phi\rangle_{010} + |\Phi\rangle_{101} + i|\Phi\rangle_{110}), \\
|+y+x-y\rangle &= \frac{1}{2}(|\Phi\rangle_{000} - i|\Phi\rangle_{011} + |\Phi\rangle_{100} - i|\Phi\rangle_{111}), \\
|+y-x+y\rangle &= \frac{1}{2}(|\Phi\rangle_{000} + i|\Phi\rangle_{011} - |\Phi\rangle_{100} - i|\Phi\rangle_{111}), \\
|-y+x+y\rangle &= \frac{1}{2}(|\Phi\rangle_{000} + i|\Phi\rangle_{011} + |\Phi\rangle_{100} + i|\Phi\rangle_{111}), \\
|+y-x-y\rangle &= \frac{1}{2}(|\Phi\rangle_{001} - i|\Phi\rangle_{010} - |\Phi\rangle_{101} + i|\Phi\rangle_{110}), \\
|-y+x-y\rangle &= \frac{1}{2}(|\Phi\rangle_{001} - i|\Phi\rangle_{010} + |\Phi\rangle_{101} - i|\Phi\rangle_{110}), \\
|-y-x+y\rangle &= \frac{1}{2}(|\Phi\rangle_{001} + i|\Phi\rangle_{010} - |\Phi\rangle_{101} - i|\Phi\rangle_{110}), \\
|-y-x-y\rangle &= \frac{1}{2}(|\Phi\rangle_{000} - i|\Phi\rangle_{011} - |\Phi\rangle_{100} + i|\Phi\rangle_{111}),
\end{aligned} \tag{4}$$

or

$$\begin{aligned}
|+y+y+x\rangle &= \frac{1}{2}(|\Phi\rangle_{001} + |\Phi\rangle_{011} + i|\Phi\rangle_{100} + i|\Phi\rangle_{110}), \\
|+y+y-x\rangle &= \frac{1}{2}(|\Phi\rangle_{000} - |\Phi\rangle_{010} + i|\Phi\rangle_{101} - i|\Phi\rangle_{111}), \\
|+y-y+x\rangle &= \frac{1}{2}(|\Phi\rangle_{000} + |\Phi\rangle_{010} - i|\Phi\rangle_{101} - i|\Phi\rangle_{111}), \\
|-y+y+x\rangle &= \frac{1}{2}(|\Phi\rangle_{000} + |\Phi\rangle_{010} + i|\Phi\rangle_{101} + i|\Phi\rangle_{111}), \\
|+y-y-x\rangle &= \frac{1}{2}(|\Phi\rangle_{001} - |\Phi\rangle_{011} - i|\Phi\rangle_{100} + i|\Phi\rangle_{110}), \\
|-y+y-x\rangle &= \frac{1}{2}(|\Phi\rangle_{001} - |\Phi\rangle_{011} + i|\Phi\rangle_{100} - i|\Phi\rangle_{110}), \\
|-y-y+x\rangle &= \frac{1}{2}(|\Phi\rangle_{001} + |\Phi\rangle_{011} - i|\Phi\rangle_{100} - i|\Phi\rangle_{110}), \\
|-y-y-x\rangle &= \frac{1}{2}(|\Phi\rangle_{000} - |\Phi\rangle_{010} - i|\Phi\rangle_{101} + i|\Phi\rangle_{111}).
\end{aligned} \tag{5}$$

However, when Alice, Bob, and Charlie prepare their photons in the bases with odd σ_Y , such as $\sigma_Y \otimes \sigma_X \otimes \sigma_X$, $\sigma_X \otimes \sigma_Y \otimes \sigma_X$, $\sigma_X \otimes \sigma_X \otimes \sigma_Y$, $\sigma_Y \otimes \sigma_Y \otimes \sigma_Y$, any three-photon product state will be a superposition of eight GHZ states with an equal probability of 1/8. For instance, the three-photon product state $|+y+x+x\rangle$ prepared in $\sigma_Y \otimes \sigma_X \otimes \sigma_X$ basis can be described in the three-photon GHZ-state basis as follows:

$$|+y+x+x\rangle = \frac{1}{4}[(1+i)(|\Phi\rangle_{000} + |\Phi\rangle_{010} + |\Phi\rangle_{100} + |\Phi\rangle_{110}) + (1-i)(|\Phi\rangle_{001} + |\Phi\rangle_{011} + |\Phi\rangle_{101} + |\Phi\rangle_{111})]. \quad (6)$$

Therefore, for any three-photon product state, it can be described in the GHZ-state basis by a deterministic superposition. Once the three photons are prepared in the bases with even σ_Y , the GHZ-state analysis of them will report one of four GHZ states, whereas the GHZ-state analyzer will report one of eight GHZ states when they are prepared in the bases with odd σ_Y . The former case will be used for security check, because any eavesdropper will distort the GHZ-state analysis and can lead to a GHZ state that is not contained in the superposition, shown in Eqs. (2)-(5).

Step (3) Security check. David announces the results of GHZ-state analysis through public channels, together with the corresponding position of the photons. Alice, Bob, and Charlie keep the raw data of successful GHZ-state analysis and discard the rest. To detect eavesdropping, Alice publishes the positions of single photons originating from P_s in sequence P_A and asks Bob and Charlie to publish their photon states with the same order in P_B and P_C . By using the cases in which they have prepared three photons in bases with even σ_Y , Alice will calculate the error rate of the photon-sequence transmission and judges whether there is an eavesdropper or unfaithful participant intercepting the quantum channel. When the error rate is larger than the threshold, she will stop the communication process and asks Bob and Charlie to restart from step (1); otherwise, she moves to the next procedure for message encoding.

Step (4) Message encoding. After the security check is passed, Alice encodes her secret message on the photons in a modified sequence $P_{K''}$ which is a subsequence of P_K and their counterparts have led to a faithful GHZ-state analysis. Specifically, if the bit value is 0, she does not perform any operation on the corresponding photon, if the bit value is 1, she performs a unitary operation $U = |0\rangle\langle 0| - |1\rangle\langle 1|$ on the corresponding photon, which completes the transformation $|+x\rangle \leftrightarrow |-x\rangle$ and $|+y\rangle \leftrightarrow |-y\rangle$. Meanwhile, Alice encodes some sampling bits together with the message encoding for integrity check.

Step (5) Message decoding. In practice, there are two methods for Bob and Charlie to decode the message sent by Alice: (I) Alice sends the photons carrying her message to Bob (Charlie) who can read out the message by measuring the photons in the right bases after Charlie (Bob) publishes his photon states; when the measure-

TABLE I: Quantum state of photons remained in Alice's node for four different cases when David announces a GHZ state $|\Phi\rangle_{b_1 b_2 0}$. α is the number of σ_Y basis that Bob and Charlie use for single-photon preparation; β is the number of states $| -x\rangle$ and $| -y\rangle$ that Bob and Charlie prepared; γ_j is the number of state $|1\rangle$ in each $|\omega\rangle_j$ that are prepared in the σ_Y basis; Case 1: α and β are both even ($\alpha = 0$ or $\alpha = 2$, $\beta = 0$ or $\beta = 2$); Case 2: α is even while β is odd ($\alpha = 0$ or $\alpha = 2$, $\beta = 1$); Case 3: α is odd while β is even ($\alpha = 1$, $\beta = 0$ or $\beta = 2$); Case 4: α and β are both odd ($\alpha = 1$, $\beta = 1$).

$\alpha - 2\gamma_j$	Case 1	Case 2	Case 3	Case 4
0	$ -x\rangle$	$ +x\rangle$	-	-
2	$ +x\rangle$	$ -x\rangle$	-	-
-1	-	-	$ -y\rangle$	$ +y\rangle$
1	-	-	$ +y\rangle$	$ -y\rangle$

TABLE II: Quantum state of photons remained in Alice's node for four different cases when David announces a GHZ state $|\Phi\rangle_{b_1 b_2 1}$. The parameters α , β , and γ_j in combination with four cases are the same as that in Table I.

$\alpha - 2\gamma_j$	Case 1	Case 2	Case 3	Case 4
0	$ +x\rangle$	$ -x\rangle$	-	-
2	$ -x\rangle$	$ +x\rangle$	-	-
-1	-	-	$ +y\rangle$	$ -y\rangle$
1	-	-	$ -y\rangle$	$ +y\rangle$

ment result coincides with that determined by Tables I and II, Bob (Charlie) receives a bit value 0, otherwise, he receives a bit value 1. Subsequently, Alice publishes her information about sampling bits and Bob (Charlie) can check the integrity of the second sequence transmission. (II) Alice measures the photons in the right bases and publishes her results over a classical channel, after she receives the basis information that Bob and Charlie use for their photon preparation; Bob (Charlie) can then read out the message after Charlie (Bob) informs him of his photon states. Although one of the communication parties performs measurement on photons carrying sender's information, the outcome is published immediately after the measurement, which never leads to any security compromise. Therefore, our protocol is MDI and can be immune to all side-channel attacks on practical measurement apparatuses [22].

III. SECURITY ANALYSIS

So far, we have presented the three-party sender-controlled MDI-QSS protocol. An unfaithful receiver Bob, in principle, can obtain Alice's private information if he can determine the states of photons in sequence P_A and hides himself in security check by introducing no disturbance. For instance, Bob can escape from being detected by Alice if he always announces his single-photon states after he knows the states of single photons pro-

duced by Alice, then he can obtain Alice's private information without Charlie's help if Alice sends her photon sequence $P_{K''}$ to Bob for message decoding and Bob measures them in proper bases. Therefore, Bob can focus his attack on acquiring Alice's single-photon states using two different strategies: (I) intercept-resend attacks; (II) teleportation-based attacks. We will show below that both attacks can not get any useful information for Bob without being detected by the sender Alice.

(I) Intercept-resend attacks. A direct intercept-resend attack performed by the unfaithful participant Bob can be carried out as follows: Bob intercepts each photon of sequence P_A and measures it in a randomly chosen basis σ_X or σ_Y . He prepares a photon with the same state as her measurement outcome and sends it to David. Subsequently, Bob can completely obtain private information sent by Alice without Charlie's help if he can evade Alice's security check and Alice sends her photon sequence $P_{K''}$ to him. Fortunately, this intercept-resend attack will be detected by Alice during the security check in step (3); Alice stops her message encoding immediately after she finds the unfaithful participant and leaks none of her private message.

Alice uses single photons of sequence P_A originating from P_S in combination with single photon states prepared by Bob and Charlie for security check. In principle, David can only report one of four GHZ states, when zero or two of three legitimate parties prepared their single photons in the σ_Y basis; meanwhile, any two parties can infer the photon state prepared by the third party. Therefore, Bob can know Alice's photon state and then evades security check if he measures Alice's single photon in the basis she prepared it. However, Bob will disturb the outcome of David's GHZ-state analysis, if he measures Alice's photon with a conjugate basis with respect to Alice's preparation basis and sends David a photon in the corresponding state. Both cases take place with an equal probability of 1/2 and half of the later leads to an error outcome of David's GHZ-state analysis. Therefore, the sender Alice always asks Bob and Charlie to announce their states and determines whether even number of them prepare their photons in basis σ_Y . Consequently, she can detect the intercept-resend attack by an average probability of 1/4 for each single sampling process, leading to a deterministic detection of the attack with a larger sampling subset.

(II) Teleportation-based attacks. In a teleportation-based attack, Bob prepares a sequence of single photons P_B and a sequence of maximally entangled photon pairs in state $|\varphi^-\rangle = (|01\rangle - |10\rangle)/\sqrt{2}$. He divides the photon pairs into two photon sequences P_{S1} and P_{S2} by rearranging two photons of each pair into different photon sequences without changing their orders. One photon sequence P_{S1} replaces photon sequence P_A and is sent to David for GHZ-state analysis, whereas the other sequence P_{S2} is kept in his hand for subsequent operations. For instance, Bob can perform a collective measurement of each photon pair $AS2_i$, consisting of photons A_i and

$S2_i$ with the same order i in P_A and P_{S2} .

When David's GHZ-state analysis of P_{S1} , P_B , and P_C succeeds, each photon in sequence P_{S2} will be projected into an eigenstate of either σ_X or σ_Y , which is identical to that described in Tables I and II. A proper two-photon measurement performed on each photon pair $AS2_i$ leads to two distinct results: Bob can infer the state of Alice's photon K_i used for message encoding, if photons A_i and K_i come from the same entangled photon pair and are initialized to $|\varphi^-\rangle$; otherwise, Bob can only get a random result, if A_i comes from single photon sequence P_S and has no correlated photon. In the latter case, photons A_i and $S2_i$ are both in an eigenstate of either σ_X or σ_Y , although the state of A_i is prepared by Alice and the state of $S2_i$ is a collapsed state of an entangled photon pair according to Tables I and II. The most efficient strategy for Bob is measuring each A_i with a random basis σ_X or σ_Y and publishing his photon state B_i involving in GHZ-state analysis accordingly. Therefore, this teleportation-based attack will expose Bob's attack with the same probability as that of the intercept-resend attack when Alice performs security check.

IV. MULTIPARTY SENDER-CONTROLLED MDI-QSS PROTOCOL

The sender-controlled three-party MDI-QSS protocol, in principle, can be generalized to implement QSS involving $(n + 1)$ parties. In a sender-controlled multiparty MDI-QSS protocol, the sender Alice can divide her message into n parts and sends them to n parties. The procedures of multiparty protocol is similar to that of three-party one, except that $n \geq 3$ rather than two receivers randomly prepare their photons in state $|\pm x\rangle$ or $|\pm y\rangle$ and send them to David for $(n + 1)$ -photon GHZ state analysis. In principle, the $(n + 1)$ -photon GHZ state analysis can be achieved by quantum erasure and postselection that has been used to construct the three-photon GHZ state analysis [49], shown in Fig. 1. For instance, a six-photon GHZ state analysis using passive linear optics with efficiency $1/2^5$ has been used to prepare twelve-photon GHZ states $(|0\rangle^{\otimes 6} + |1\rangle^{\otimes 6})/\sqrt{2}$ out of entangled photon pairs [56]. Furthermore, the $(n + 1)$ -photon GHZ state analysis can be achieved with near-unity efficiency by using nonlinear optics [57–59], such as a deterministic interface between single photons and individual electron spins [60–63]. Here, we focus on the security check and briefly discuss how to complete the multiparty sender-controlled MDI-QSS protocol by encoding and decoding message.

The sender Alice prepares two photon sequences P_A and P_K with the same method as described in three-party protocol and sends P_A to David. Meanwhile, n receivers (Bob₁, ..., Bob_n) prepare n photon sequences $P_B^{(i)}$ with $i = 1, \dots, n$ and send them to David for $(n + 1)$ -photon GHZ state analysis. Exclusive correlations among $(n + 1)$ legitimate parties will be established, when

David announces a successful result of his GHZ-state analyzer.

For each $(n+1)$ photon with the same order in P_A and $P_B^{(i)}$, α $(n+1-\alpha)$ parties prepare their single photons in the σ_Y (σ_X) basis; β $(n+1-\beta)$ receivers prepare their single photons in either the state $| -x \rangle$ or $| -y \rangle$ ($| +x \rangle$ or $| +y \rangle$). A $(n+1)$ -photon product state of these photons can be described as

$$|\xi\rangle = \frac{1}{\sqrt{N}} \sum_{j=1}^N i^{\gamma_j} (-1)^{\eta_j} |\omega\rangle_j, \quad (7)$$

where $N = 2^{(n+1)}$; $|\omega\rangle_j = |b_0 \cdots b_n\rangle$ is a $(n+1)$ -photon product state in the σ_Z basis with $b_k \in \{0, 1\}$ for $k = 0, \dots, n$; γ_j of α photons that are prepared in the σ_Y basis are in $|1\rangle$ state in each $|\omega\rangle_j$; η_j of β photons that are prepared in either the state $| -x \rangle$ or $| -y \rangle$ are in $|1\rangle$ state in each $|\omega\rangle_j$. Meanwhile, $|\xi\rangle$ can also be described as a superposition of $(n+1)$ -photon states $|\bar{\omega}\rangle_j = |\bar{b}_0 \cdots \bar{b}_n\rangle$ with $\bar{b}_k = 1 - b_k$ as follows:

$$|\xi'\rangle = \frac{1}{\sqrt{N}} \sum_{j=1}^N i^{\alpha-\gamma_j} (-1)^{\beta-\eta_j} |\bar{\omega}\rangle_j. \quad (8)$$

Therefore, the state $|\xi\rangle$ can be rewritten as a superposition of $|\omega\rangle_j$ and $|\bar{\omega}\rangle_j$ as follows:

$$|\xi''\rangle = \frac{1}{\sqrt{2N}} \sum_{j=1}^N (-1)^{\eta_j} i^{\gamma_j} [|\omega\rangle_j + i^{\alpha-2\gamma_j} (-1)^{\beta} |\bar{\omega}\rangle_j]. \quad (9)$$

The $(n+1)$ -photon GHZ-state measurement performed by David can collapse the state $|\xi''\rangle$ into one of $2^{(n+1)}$ GHZ states $|\Phi\rangle_{a_0 \cdots a_n}$, i.e.,

$$|\Phi\rangle_{a_0 \cdots a_n} = \frac{1}{\sqrt{2}} [|0a_0 \cdots a_{n-1}\rangle + (-1)^{a_n} |1\bar{a}_0 \cdots \bar{a}_{n-1}\rangle], \quad (10)$$

where $a_k \in \{0, 1\}$, $k = 0, \dots, n$, and $\bar{a}_k = 1 - a_k$.

In practice, David can only identify two of $2^{(n+1)}$ GHZ states, i.e., $|\Phi\rangle_{00 \cdots 0} = (|00 \cdots 0\rangle + |11 \cdots 1\rangle)/\sqrt{2}$ and $|\Phi\rangle_{00 \cdots 1} = (|00 \cdots 0\rangle - |11 \cdots 1\rangle)/\sqrt{2}$, when using a GHZ-state analyzer that is constituted of linear optical elements and single-photon detectors. Clearly, the success of David's GHZ-state analysis will report different GHZ states for different α when no attack is involved. When α is even, the state $|\xi''\rangle$ will be specified as a superposition of 2^n $(n+1)$ -photon GHZ states, in which one of each GHZ-state pair ($|\Phi\rangle_{a_0 \cdots a_{n-1}0}$ and $|\Phi\rangle_{a_0 \cdots a_{n-1}1}$) with different phases appears. The outcome of David's GHZ-state analysis will be either $|\Phi\rangle_{a_0 \cdots a_{n-1}0}$ or $|\Phi\rangle_{a_0 \cdots a_{n-1}1}$ with a probability of $1/2^n$ for $a_j = 0$ ($j = 0, \dots, n-1$). However, when α is odd, the state $|\xi''\rangle$ will be specified as a superposition of $2^{(n+1)}$ $(n+1)$ -photon GHZ states and $|\Phi\rangle_{a_0 \cdots a_{n-1}0}$ and $|\Phi\rangle_{a_0 \cdots a_{n-1}1}$ appear with an equal probability of $1/2^{(n+1)}$. This is the key for performing security check, since both outside eavesdropping and participant attack will disturb the outcome of David's GHZ-state analysis and Alice can detect the disturbance after

n receivers inform her of their photon states. Likewise, exclusive correlations are established between photons kept in Alice's node and single photons prepared by n receivers when David reports a successful outcome of his $(n+1)$ -photon GHZ-state analysis using linear optics: The outcome is either $|\Phi\rangle_{a_0 \cdots a_{n-1}0}$ or $|\Phi\rangle_{a_0 \cdots a_{n-1}1}$ with an equal probability of $1/2^{(n+1)}$. The parties then can complete the multiparty sender-controlled MDI-QSS protocol by using similar message encoding and decoding procedures to that in three-party one, after Alice ascertains the security of photon-sequence transmission.

V. DISCUSSION AND SUMMARY

In the photon-sequence transmission, we suppose that the quantum channel is ideal without any noise and thus does not change the polarization of photons transmitting over it. In practice, the channel noise will introduce depolarization and dephasing to photons that transmit directly over a quantum channel. This changes the states of photons entering the GHZ-state analyzer, and prevents the communication parties from sharing perfect correlation shown in Tables I and II. Then it increases the bit-error rate of random sampling in the security check. Fortunately, the influence of the channel noise can be suppressed by using photonic logical qubits, which are encoded in decoherence-free subspaces and are robust to channel noise [64–67]. The GHZ state analyzer should be modified accordingly. When the bit-error rate is relatively low, forward error correction with redundant encoding can provide a passive method to suppress the influence of quantum channel noise and has been used to perform QSDC [68–70]. For instance, a five-repetition-per-bit encoding can decrease a bit-error rate of $p_0 \leq 0.1$ to $p_1 \leq 0.0081$ for the DL04-QSDC protocol [70–72].

The GHZ-state analyzer situated in an ancillary node plays an important role in our sender-controlled MDI-QSS protocol and it can be partly implemented by linear optical elements and single photon detectors [49–51]. In practice, this type of the GHZ-state analyzer can only distinguish two GHZ states from the other $(2^n - 2)$ n -photon GHZ states. This imposes a restriction on the transmission efficiency of the MDI-QSS protocol and decreases the efficiency exponentially with the number of receivers. Fortunately, this restriction can be lifted by using nonlinear optical elements [60–62], which leads to a deterministic GHZ-state analyzer [57–59] and then multiphoton postselected entanglement generation or teleportation.

For a sender-controlled MDI-QSS protocol involving n receivers, single photons with random polarization are inserted into entangled photon pairs for security check. Half of cases with desired outputs of the GHZ-state analyzer contribute to security check, in which even number of basis σ_Y are used for single photon preparation. A modified sender-controlled n -receiver MDI-QSS protocol can be obtained from the original DMDI-QSS one [48], if

the sender prepares photon pairs and single photons with the same length and sends two photon sequences in step (2) to ancillary node for the GHZ-state analysis of $(n+2)$ photons. This protocol equals to the original DMDI-QSS after moving one receiver of the later to sender's node and can be inherently robust to any participant attack, because it involves at least two faithful receivers, the combination of which, ascertaining security check, is out of reach of any other receivers. In principle, the modified protocol requires no basis reconciliation, each case with a desired output of the GHZ-state analyzer contributes to either security check or secret sharing. However, the efficiency of the security check in the modified one is identical to that of the sender-controlled MDI-QSS and equals to $1/2^{(n+1)}$ when GHZ-state analyzer is implemented by linear optical elements and single photon detectors.

In summary, we have proposed a sender-controlled MDI-QSS protocol. The sender performs security check actively using postselected multiphoton entanglement that is generated by the GHZ-state analysis of $(n+1)$ single photons. When even number of parties prepare their single photons in basis σ_Y , an ideal outcome of GHZ-state analysis is in a subspace of 2^n dimensions. Attacks

from either outside eavesdropper or unfaithful participant will introduce deviation from ideal outputs and can create postselected multiphoton entanglement orthogonal to the desired ones. The states of single photons prepared by the sender is the single variable that determines the ideal outputs after all receivers have published their photon states. Therefore, the sender performs as an active controller and only encodes private messages after the sender checks the security of photon-sequence transmission. This makes our protocol useful for multiparty quantum communication networks.

ACKNOWLEDGMENTS

This work was supported by the National Natural and Science Foundation of China (Grant No. 11904171) and the Natural Science Foundation of Jiangsu Province (Grant No. BK20180461).

-
- [1] N. Gisin, G. Ribordy, W. Tittel, and H. Zbinden, "Quantum cryptography," *Rev. Mod. Phys.* **74**, 145–195 (2002).
- [2] Z.-X. Cui, W. Zhong, L. Zhou, and Y.-B. Sheng, "Measurement-device-independent quantum key distribution with hyper-encoding," *Sci. China-Phys. Mech. Astron.* **62**, 110311 (2019).
- [3] T. Shang, Y. Tang, R. Chen, and J. Liu, "Full quantum one-way function for quantum cryptography," *Quantum Eng.* **2**, e32 (2020).
- [4] Y.-F. Yan, L. Zhou, W. Zhong, and Y.-B. Sheng, "Measurement-device-independent quantum key distribution of multiple degrees of freedom of a single photon," *Front. Phys.* **16**, 11501 (2020).
- [5] Y. Zhang and Q. Ni, "Design and analysis of random multiple access quantum key distribution," *Quantum Eng.* **2**, e31 (2020).
- [6] G.-L. Long and X.-S. Liu, "Theoretically efficient high-capacity quantum-key-distribution scheme," *Phys. Rev. A* **65**, 032302 (2002).
- [7] F.-G. Deng, G. L. Long, and X.-S. Liu, "Two-step quantum direct communication protocol using the Einstein-Podolsky-Rosen pair block," *Phys. Rev. A* **68**, 042317 (2003).
- [8] C. Wang, F.-G. Deng, Y.-S. Li, X.-S. Liu, and G.-L. Long, "Quantum secure direct communication with high-dimension quantum superdense coding," *Phys. Rev. A* **71**, 044305 (2005).
- [9] J.-Y. Hu, B. Yu, M.-Y. Jing, L.-T. Xiao, S.-T. Jia, G.-Q. Qin, and G.-L. Long, "Experimental quantum secure direct communication with single photons," *Light Sci. Appl.* **5**, e16144 (2016).
- [10] W. Zhang, D.-S. Ding, Y.-B. Sheng, L. Zhou, B.-S. Shi, and G.-C. Guo, "Quantum secure direct communication with quantum memory," *Phys. Rev. Lett.* **118**, 220501 (2017).
- [11] S.-S. Chen, L. Zhou, W. Zhong, and Y.-B. Sheng, "Three-step three-party quantum secure direct communication," *Sci. China-Phys. Mech. Astron.* **61**, 90312 (2018).
- [12] L.-Y. Li, T.-J. Wang, and C. Wang, "The analysis of high-capacity quantum secure direct communication using polarization and orbital angular momentum of photons," *Mod. Phys. Lett. B* **34**, 2050017 (2020).
- [13] T. Li and G.-L. Long, "Quantum secure direct communication based on single-photon Bell-state measurement," *New J. Phys.* **22**, 063017 (2020).
- [14] Z.-D. Ye, D. Pan, Z. Sun, C.-G. Du, L.-G. Yin, and G.-L. Long, "Generic security analysis framework for quantum secure direct communication," *Front. Phys.* **16**, 21503 (2020).
- [15] M. Hillery, V. Buzek, and A. Berthiaume, "Quantum secret sharing," *Phys. Rev. A* **59**, 1829–34 (1999).
- [16] R. Cleve, D. Gottesman, and H.-K. Lo, "How to share a quantum secret," *Phys. Rev. Lett.* **83**, 648–651 (1999).
- [17] W. Tittel, H. Zbinden, and N. Gisin, "Experimental demonstration of quantum secret sharing," *Phys. Rev. A* **63**, 042301 (2001).
- [18] Y.-A. Chen, A.-N. Zhang, Z. Zhao, X.-Q. Zhou, C.-Y. Lu, C.-Z. Peng, T. Yang, and J.-W. Pan, "Experimental quantum secret sharing and third-man quantum cryptography," *Phys. Rev. Lett.* **95**, 200502 (2005).
- [19] T. Gao, F.-L. Yan, and Z.-X. Wang, "Deterministic secure direct communication using GHZ states and swapping quantum entanglement," *J. Phys. A* **38**, 5761 (2005).
- [20] C. H. Bennett and G. Brassard, in *Proceedings of the IEEE International Conference on Computers, Systems and Signal Processing, Bangalore, India, 1984*, (IEEE, New York, 1984), pp.175–179.

- [21] H.-K. Lo, M. Curty, and K. Tamaki, “Secure quantum key distribution,” *Nat. Photon.* **8**, 595 (2014).
- [22] F. Xu, X. Ma, Q. Zhang, H.-K. Lo, and J.-W. Pan, “Secure quantum key distribution with realistic devices,” *Rev. Mod. Phys.* **92**, 025002 (2020).
- [23] T. Li, Z. Gao, and Z. Li, “Measurement-device-independent quantum secure direct communication: Direct quantum communication with imperfect measurement device and untrusted operator,” *EPL* **131**, 60001 (2020).
- [24] A. Acín, N. Brunner, N. Gisin, S. Massar, S. Pironio, and V. Scarani, “Device-independent security of quantum cryptography against collective attacks,” *Phys. Rev. Lett.* **98**, 230501 (2007).
- [25] C. C. W. Lim, C. Portmann, M. Tomamichel, R. Renner, and N. Gisin, “Device-independent quantum key distribution with local Bell test,” *Phys. Rev. X* **3**, 031006 (2013).
- [26] L. Zhou, Y.-B. Sheng, and G.-L. Long, “Device-independent quantum secure direct communication against collective attacks,” *Sci. Bull.* **65**, 12 – 20 (2020).
- [27] H.-K. Lo, M. Curty, and B. Qi, “Measurement-device-independent quantum key distribution,” *Phys. Rev. Lett.* **108**, 130503 (2012).
- [28] P.-H. Niu, Z.-R. Zhou, Z.-S. Lin, Y.-B. Sheng, L.-G. Yin, and G.-L. Long, “Measurement-device-independent quantum communication without encryption,” *Sci. Bull.* **63**, 1345–1350 (2018).
- [29] Z.-R. Zhou, Y.-B. Sheng, P.-H. Niu, L.-G. Yin, G.-L. Long, and L. Hanzo, “Measurement-device-independent quantum secure direct communication,” *Sci. China Phys. Mech. Astron.* **63**, 230362 (2020).
- [30] Z. Gao, T. Li, and Z. Li, “Long-distance measurement-device-independent quantum secure direct communication,” *EPL* **125**, 40004 (2019).
- [31] Z.-K. Zou, L. Zhou, W. Zhong, and Y.-B. Sheng, “Measurement-device-independent quantum secure direct communication of multiple degrees of freedom of a single photon,” *EPL* **131**, 40005 (2020).
- [32] S. Wehner, D. Elkouss, and R. Hanson, “Quantum internet: A vision for the road ahead,” *Science* **362**, eaam928 (2018).
- [33] W. Qin and F. Nori, “Controllable single-photon transport between remote coupled-cavity arrays,” *Phys. Rev. A* **93**, 032337 (2016).
- [34] Z. Qi, Y. Li, Y. Huang, J. Feng, Y. Zheng, and X. Chen, “A 15-user quantum secure direct communication network,” *Light Sci. Appl.* **10**, 183 (2021).
- [35] A. Karlsson, M. Koashi, and N. Imoto, “Quantum entanglement for secret sharing and secret splitting,” *Phys. Rev. A* **59**, 162–8 (1999).
- [36] L. Xiao, G.-L. Long, F.-G. Deng, and J.-W. Pan, “Efficient multiparty quantum-secret-sharing schemes,” *Phys. Rev. A* **69**, 052307 (2004).
- [37] H.-K. Lo, H. F. Chau, and M. Ardehali, “Efficient quantum key distribution scheme and a proof of its unconditional security,” *J. Cryptol.* **18**, 133–165 (2005).
- [38] P. Xue, K. Wang, and X. Wang, “Efficient multiuser quantum cryptography network based on entanglement,” *Sci. Rep.* **7**, 45928 (2017).
- [39] Y. Li, K. Zhang, and K. Peng, “Multiparty secret sharing of quantum information based on entanglement swapping,” *Phys. Lett. A* **324**, 420–424 (2004).
- [40] Z.-J. Zhang, Y. Li, and Z.-X. Man, “Multiparty quantum secret sharing,” *Phys. Rev. A* **71**, 044301 (2005).
- [41] Z.-J. Zhang, “Multiparty quantum secret sharing of secure direct communication,” *Phys. Lett. A* **342**, 60 – 66 (2005).
- [42] X. Yang, K. Wei, H. Ma, H. Liu, Z. Yin, Z. Cao, and L. Wu, “Detector-device-independent quantum secret sharing with source flaws,” *Sci. Rep.* **8**, 5728 (2018).
- [43] C.-Y. Huang, N. Lambert, C.-M. Li, Y.-T. Lu, and F. Nori, “Securing quantum networking tasks with multipartite Einstein-Podolsky-Rosen steering,” *Phys. Rev. A* **99**, 012302 (2019).
- [44] Y. Xiang, I. Kogias, G. Adesso, and Q. He, “Multiparty Gaussian steering: Monogamy constraints and quantum cryptography applications,” *Phys. Rev. A* **95**, 010101 (2017).
- [45] I. Kogias, Y. Xiang, Q. He, and G. Adesso, “Unconditional security of entanglement-based continuous-variable quantum secret sharing,” *Phys. Rev. A* **95**, 012315 (2017).
- [46] M. Habibidavijani and B. C. Sanders, “Continuous-variable ramp quantum secret sharing with Gaussian states and operations,” *New J. Phys.* **21**, 113023 (2019).
- [47] Y. Fu, H.-L. Yin, T.-Y. Chen, and Z.-B. Chen, “Long-distance measurement-device-independent multiparty quantum communication,” *Phys. Rev. Lett.* **114**, 090501 (2015).
- [48] Z. Gao, T. Li, and Z. Li, “Deterministic measurement-device-independent quantum secret sharing,” *Sci. China-Phys. Mech. Astron.* **63**, 120311 (2020).
- [49] J.-W. Pan and A. Zeilinger, “Greenberger-Horne-Zeilinger-state analyzer,” *Phys. Rev. A* **57**, 2208–2211 (1998).
- [50] C.-Y. Lu, T. Yang, and J.-W. Pan, “Experimental multiparticle entanglement swapping for quantum networking,” *Phys. Rev. Lett.* **103**, 020501 (2009).
- [51] P. Kok, W. J. Munro, K. Nemoto, T. C. Ralph, J. P. Dowling, and G. J. Milburn, “Linear optical quantum computing with photonic qubits,” *Rev. Mod. Phys.* **79**, 135–174 (2007).
- [52] F.-G. Deng, X.-H. Li, H.-Y. Zhou, and Z.-J. Zhang, “Improving the security of multiparty quantum secret sharing against Trojan horse attack,” *Phys. Rev. A* **72**, 044302 (2005).
- [53] Y.-G. Yang, Y.-C. Wang, Y.-L. Yang, X.-B. Chen, D. Li, Y.-H. Zhou, and W.-M. Shi, “Participant attack on the deterministic measurement-device-independent quantum secret sharing protocol,” *Sci. China-Phys. Mech. Astron.* **64**, 260321 (2021).
- [54] Y.-G. Yang, X.-X. Liu, S. Gao, X.-B. Chen, D. Li, Y.-H. Zhou, and W.-M. Shi, “A stronger participant attack on the measurement-device-independent protocol for deterministic quantum secret sharing,” *Quantum Inf. Process.* **20**, 223 (2021).
- [55] T. Gao, F.-L. Yan, and Z.-X. Wang, “Controlled quantum teleportation and secure direct communication,” *Chin. Phys. Lett.* **14**, 893 (2005).
- [56] H.-S. Zhong, Y. Li, W. Li, L.-C. Peng, Z.-E. Su, Y. Hu, Y.-M. He, X. Ding, W. Zhang, H. Li, L. Zhang, Z. Wang, L. You, X.-L. Wang, X. Jiang, L. Li, Y.-A. Chen, N.-L. Liu, C.-Y. Lu, and J.-W. Pan, “12-photon entanglement and scalable scattershot boson sampling with optimal entangled-photon pairs from parametric down-conversion,” *Phys. Rev. Lett.* **121**, 250505 (2018).
- [57] T. Li, A. Miranowicz, K. Xia, and F. Nori,

- “Resource-efficient analyzer of Bell and Greenberger-Horne-Zeilinger states of multiphoton systems,” *Phys. Rev. A* **100**, 052302 (2019).
- [58] J. Qian, X.-L. Feng, and S.-Q. Gong, “Universal Greenberger-Horne-Zeilinger-state analyzer based on two-photon polarization parity detection,” *Phys. Rev. A* **72**, 052308 (2005).
- [59] Y. Xia, Y.-H. Kang, and P.-M. Lu, “Complete polarized photons Bell-states and Greenberger-Horne-Zeilinger-states analysis assisted by atoms,” *J. Opt. Soc. Am. B* **31**, 2077–2082 (2014).
- [60] D. E. Chang, V. Vuletić, and M. D. Lukin, “Quantum nonlinear optics—photon by photon,” *Nat. Photon.* **8**, 685 (2014).
- [61] T. Li, A. Miranowicz, X. Hu, K. Xia, and F. Nori, “Quantum memory and gates using a Λ -type quantum emitter coupled to a chiral waveguide,” *Phys. Rev. A* **97**, 062318 (2018).
- [62] G.-Z. Song, E. Munro, W. Nie, L.-C. Kwek, F.-G. Deng, and G.-L. Long, “Photon transport mediated by an atomic chain trapped along a photonic crystal waveguide,” *Phys. Rev. A* **98**, 023814 (2018).
- [63] W. Qin, A. Miranowicz, P.-B. Li, X.-Y. Lü, J. Q. You, and F. Nori, “Exponentially enhanced light-matter interaction, cooperativities, and steady-state entanglement using parametric amplification,” *Phys. Rev. Lett.* **120**, 093601 (2018).
- [64] P.-L. Guo, C.-Y. Gao, T. Li, X.-H. Li, and F.-G. Deng, “Quantum error rejection for faithful quantum communication over noise channels,” *Sci. China-Phys. Mech. Astron.* **62**, 110301 (2019).
- [65] L. Aolita and S. P. Walborn, “Quantum communication without alignment using multiple-qubit single-photon states,” *Phys. Rev. Lett.* **98**, 100501 (2007).
- [66] W. Qin, C. Wang, and X. Zhang, “Protected quantum-state transfer in decoherence-free subspaces,” *Phys. Rev. A* **91**, 042303 (2015).
- [67] N. Shammah, S. Ahmed, N. Lambert, S. De Liberato, and F. Nori, “Open quantum systems with local and collective incoherent processes: Efficient numerical simulations using permutational invariance,” *Phys. Rev. A* **98**, 063815 (2018).
- [68] R. Qi, Z. Sun, Z. Lin, P. Niu, W. Hao, L. Song, Q. Huang, J. Gao, L. Yin, and G.-L. Long, “Implementation and security analysis of practical quantum secure direct communication,” *Light Sci. Appl.* **8**, 22 (2019).
- [69] F. Massa, A. Moqanaki, F. Del Santo, B. Dakic, and P. Walther, “Experimental two-way communication with one photon,” *Adv. Quantum. Technol.* **2**, 1900050 (2019).
- [70] Z. Gao, M. Ma, T. Liu, J. Long, T. Li, and Z. Li, “Free-space quantum secure direct communication based on decoherence-free space,” *J. Opt. Soc. Am. B* **37**, 3028–3033 (2020).
- [71] F.-G. Deng and G. L. Long, “Secure direct communication with a quantum one-time pad,” *Phys. Rev. A* **69**, 052319 (2004).
- [72] J. Wu, Z. Lin, L. Yin, and G.-L. Long, *Quantum Eng.* **1**, e26 (2019).