DEEP CONTEXTUALIZED PAIRWISE SEMANTIC SIMILARITY FOR ARABIC LANGUAGE QUESTIONS

Hesham Al-Bataineh

AI Department
Mawdoo3 Ltd
Amman, Jordan
hisham.bataineh@mawdoo3.com

Wael Farhan

AI Department
Mawdoo3 Ltd
Amman, Jordan
wael.farhan@mawdoo3.com

Ahmad Mustafa

AI Department
Mawdoo3 Ltd
Amman, Jordan
ahmad.mustafa@mawdoo3.com

Haitham Seelawi

haitham.seelawi@gmail.com

Hussein T. Al-Natsheh

AI Department
Mawdoo3 Ltd
Amman, Jordan
h.natsheh@mawdoo3.com

September 23, 2019

ABSTRACT

Question semantic similarity is a challenging and active research problem that is very useful in many NLP applications, such as detecting duplicate questions in community question answering platforms such as Quora. Arabic is considered to be an under-resourced language, has many dialects, and rich in morphology. Combined together, these challenges make identifying semantically similar questions in Arabic even more difficult. In this paper, we introduce a novel approach to tackle this problem, and test it on two benchmarks; one for Modern Standard Arabic (MSA), and another for the 24 major Arabic dialects. We are able to show that our new system outperforms state-of-the-art approaches by achieving 93% F1-score on the MSA benchmark and 82% on the dialectal one. This is achieved by utilizing contextualized word representations (ELMo embeddings) trained on a text corpus containing MSA and dialectic sentences. This in combination with a pairwise fine-grained similarity layer, helps our question-to-question similarity model to generalize predictions on different dialects while being trained only on question-to-question MSA data.

Keywords Arabic, natural language processing , semantic textual similarity, question answering, deep learning

1 Introduction

A question is a linguistic form that does not necessarily provide information as in a sentence but may carry semantic information. The closest level of granularity to the question form is the sentence form rather than word or paragraph. The answer, on the other hand, could be mapped either to a sentence or a paragraph as the closest granularity. In this work, we are focusing on Semantic Textual Similarity (STS) of a question pair with the main assumption that if two questions have the same answers, then they are semantically equivalent. Otherwise, if the answers are different or partially different (e.g., the answer of the first question is included in the answer of the second question but considered incomplete, or the questions share a portion of their answers yet different otherwise) then the pair is considered as semantically nonequivalent.

STS deals with resolving semantic similarity between the different levels of expression in a given language (e.g. words, sentences, paragraphs). At heart, STS is a Natural Language Understanding (NLU). With the advent of deep learning methods and its applications in NLU, STS has especially witnessed huge advances, such as reported by [1] and [2]. These advances have resulted in the development of complex applications in the field that previously were thought

very difficult to achieve. Nonetheless, it seems that STS in Arabic is yet to reap these benefits. Despite a plethora of literature reporting Arabic STS systems developed using conventional machine learning methods [3], only a few of them utilize dense word representations in STS related tasks, let alone deep learning [4].

Our interest in tackling this problem stems from the fact that one of the most relevant use-cases of STS for question pairs is identifying duplicate questions in community question answering platforms. In such platforms, the user provides a question that might be already asked and answered by the community but the question might be phrased differently. Looking for an exact match, even after text normalization, would not solve the problem and would result in information duplication and a waste of efforts in answering already answered questions. It is an intellectual task that a human would best decide if two questions, or more, are semantically equivalent. For example, the following pair of questions; “How to prepare scrambled eggs?” and “ What are the steps of making good scrambled eggs?” could have the same answer, however, a text matching approach would not identify that they are semantically similar. Search engines of a question repository, for example, FAQ, is another application where such a question-to-question (Q2Q) similarity model would be very useful. Digital assistants like chat-bots or voice assistants also need such NLU model to map the user question to already indexed answered questions.

Therefore, it is in this vein that we produce and publish this work; in it, we attempt to develop state of the art Arabic Q2Q systems, that utilize recent advances in the field. By this, we hope to encourage other members of the Arabic Computational Linguistics community to open up to and embrace the game-changing methodologies of deep learning, and its potential to revolutionize Arabic NLP and NLU.

Working in Arabic Q2Q similarity can be a challenging task due to several factors:

1. **Under-resourced:** Arabic Q2Q datasets are scarce and limited in size.
2. **Dialectic:** Modern Standard Arabic (MSA) is not commonly used in social media, as most users prefer using their own dialect (a variation of the language). Where each dialect has its own vocabulary and mutations of existing words. Training models for dialects can be problematic for two main reasons. First, there is not enough labeled dataset available for each dialect. e.g., Quora Question Pair¹ and other datasets support standard English, but very few support Scottish, Irish, and other dialects. This applies to most languages including Arabic. Secondly, if labeled dialectic data is abundant then it would be tedious to train one model per dialect, where each model cannot jointly find similar pairs between different dialects.
3. **Morphologically rich:** The Arabic language is one of the most morphologically rich languages which complicates training traditional word embedding algorithms such as Word2vec as it needs to learn a completely new embedding for each morphology.

The main purpose of this paper is to tackle those issues and set a new state-of-the-art Q2Q similarity score for the Arabic language. Our contributions can be summarized into the following points:

1. Build a new Q2Q standard Arabic dataset [5] that is publicly available and large enough to train deep learning models. Currently, this is the largest Arabic Q2Q dataset.
2. We extract a Q2Q evaluation dataset from MADAR Arabic dialect parallel corpora [6]. This second test set is created to evaluate our models on how they generalize on different dialects.
3. Train a new ELMo model that starts with a character-level convolutional neural network (CNN) to overcome the hurdle of morphology and out-of-vocabulary (OOV). The training corpus was collected from various sources that include dialectic data. Our word embeddings model achieves better results than the best known Arabic word embeddings AraVec [7]
4. We build a deep learning network that is only trained on MSA without including any dialectic question pairs in the training set. Then, we show that this network is able to generalize and achieve high F1 score on the dialectic test set.

In section 2, we discuss previously published work relating to Q2Q in Arabic. We confine our review to research that utilizes the recent advances in neural networks. Section 3 describes datasets collected to train our models, while section 4 dives into our approaches. Next, we describe our experiments and analyze the results in section 5. Finally, we conclude in section 6.

¹<https://data.quora.com/First-Quora-Dataset-Release-Question-Pairs>

2 Related Work

There is not much work on Arabic Q2Q semantic similarity in particular. However, there are a few in Arabic sentence similarity (e.g., STS) and a lot in other languages, mainly in English. In this section, we will provide a related work review of sentence STS similarity approaches categorized into three main approaches, unsupervised models, deep learning models, and computational linguistics approach.

In the unsupervised models, Nagoudi et al. [8] are among the first to use dense word representations to tackle STS in Arabic. They propose the usage of Word2vec embeddings [9], by carrying a point-wise summation of the dense vector representation of each constituent word for each sentence in a given pair. They then use cosine similarity on the resultant vector representations to score how semantically similar or not the two sentences are. They have used the CBOW variant of the Word2vec model proposed in [10], which is trained on an Arabic corpus of about 5.8 billion tokens.

They have experimented with weighing the summations using tf-idf and part-of-speech (POS) tagging, in juxtaposition with no weighting at all. The testing dataset they have used consists of 750 sentences from the MSR-Video corpus, which was manually translated to Arabic. They have found that the two weighting schemes (78.20% Pearson correlation for tf-idf, and 79.69% for POS tagging) significantly outperforms not using weighting at all (72.33%). This is expected, given that the words making up a given sentence do not contribute equally to its semantics. However, while tf-idf weights are automatically chosen from the training text, assigning weights to POS tags requires domain knowledge. In our approach, we achieve better results without requiring domain knowledge.

As mentioned in the introduction, there is a lack of deep learning studies on the topic of STS in Arabic. As part of their efforts for SemEval-2017 Task 1, [11] and [12] successfully but *indirectly* use a standalone, end-to-end deep learning solution for detecting semantic similarity between pairs of Arabic sentences. By indirectly, we mean that they train the system on English pairs, and then for inference, they translate the pairs from Arabic to English using Google Translate service.

The architecture of the system itself is heavily inspired by the Convolutional Deep Structured Semantic Model as suggested by [13]. The model uses Glove embeddings [14] to represent words. Additionally, the POS tag is appended, as a one-hot encoding vector, to the Glove representation of its corresponding token. As such, each sentence is modeled as a matrix of dense representations (for words) plus sparse representations (for POS), arranged in a manner corresponding to the order of the words in the original sentence. The matrix is then padded/truncated to a maximum sentence length.

The matrices of a pair of sentences are then processed using a convolutional neural network [15] with 300 one-dimensional filters, and a max-pooling step [16]. The resultant sentence vector representations are then subjected to two more transformations: an absolute point-wise difference, and a point-wise multiplication, both, between the two said vectors. These are then concatenated and fed into a feed-forward network, which predicts the similarity between two sentences on a scale between 1 to 5.

This system have scored competitively in the task, with a 71.30% Pearson correlation score. They attempted to run the same system without the machine translation step, which yielded a score that was significantly worse, 43.73%. This can be attributed to two factors. The first is the fact that the Arabic dataset is much smaller in comparison to the English dataset. This is corroborated by a similar drop in the score that is observed in the Spanish pairs' track under the same conditions. The second is the fact that dense word representations, as obtained for a language such as English, can be inadequate for a morphologically rich language such as Arabic without incorporating these morphological features into the calculation of these word embeddings [17]. Our methods do not use machine translation because it may produce incorrect translations especially when the system has to grasp the nuance of the text and take the context into account. This induces errors that propagate through the system and results in loosing information such as not capturing Arabic morphology.

In the approach of computational linguistics, a sentence-based similarity measure could be defined by also counting for the syntactic structure of the sentence [18]. Authors of this paper divide the sentence into 3 components: subject, predicate, and object as the key components. However, they also include some modifier components which are attributive, adverbial, and complement.

Our approach combines the power of unsupervised learning through contextualized word embeddings and supervised deep pairwise fine-grained similarity network that outperforms state-of-the-art.

3 Data

There are plenty of datasets available for STS tasks in English language, for example: SQuAD [19], CoQA [20], Quora Question Pairs (QQP) ² and Semantic Textual Similarity Benchmark [11]. However, when it comes to the Arabic language there is a shortage and difficulty in finding such datasets. To overcome this issue we build our own Q2Q dataset for training and extract dialect test for evaluation. In addition, we collected large text corpus to train word and sentence embeddings. The following subsections provide more details on these datasets.

3.1 Mawdoo3 Q2Q Dataset

This dataset has been developed, annotated, and verified by the annotation team of *Mawdoo3 Ltd*³ [5]. It consists of 3 fields, i.e. *question1* containing the text for one of the question pairs, *question2* containing the text of the second question, and *label* which is either 1 if question1 and question2 have similar answer, or 0 if their answers are different. The collected questions are written (not spoken) factoid questions. For example:

من هو رئيس الولايات المتحدة الأمريكية؟

which translates to “Who is the president of the United States of America?”.

The total number of unique question pairs in the *training dataset* is 11,997. 6,600 of them are labeled as ‘0’, and the remaining 5,397 pairs are ‘1’.

Before using the data to train the models, we run multiple pre-processing steps. We remove all special characters and punctuation marks except Arabic punctuation marks such as commas and full stops. We add space before and after the remaining punctuation marks so that they would be considered as tokens. Our final pre-processing step is to remove letter elongations like وّ (waw waw) and يّ (ya ya). The questions are relatively short, with most of the questions averaging between 4 to 10 words per question.

3.2 Madar Dialect Q2Q Dataset

MADAR dataset [21] is a parallel corpora of Arabic dialectic and MSA sentences. Each entry in MADAR consists of a sentence in MSA, the dialectic translation of that sentence, and the city where the dialect is spoken. This dataset contains dialects of 24 cities. It is based on tourism-related sentences, hence it is conversational in nature and comprises a lot of questions.

We use MADAR dataset to extract Q2Q pairs similar in format to the dataset described in the previous subsection (i.e., question1, question2, and label). For each dialect, we first select the questions from MADAR dataset. Then, we label these question pairs with ‘1’ to indicate that those questions are similar. Next, we generate negative samples by randomly matching a question from MSA with any other question within the same dialect. Finally, we balance the number of instances to make sure that all dialects have equal number of question pairs. Each dialect has 1,686 question pairs equally divided between similar pairs and the ones that are not. This will make a total of 40,464 pairs across all 24 dialects. We run the same pre-processing steps that we apply on Mawdoo3 Q2Q dataset.

3.3 Text Corpus

To train our embedding models (Sections 4.5 and 4.2) we have collected a large dataset from three sources: (i) Tweets (ii) Arabic Wikipedia (iii) Mawdoo3 articles.

Twitter is a major data source for many NLP researchers. This might be due to multiple reasons. Mainly the huge amount of data that can be collected and the diversity of the subjects that tweets can cover.

The Arabic content on the web may contain several local dialects (e.g., Egyptian, Moroccan, Gulf, Levantine dialects, etc.). Arabic dialects can significantly vary from MSA. Twitter contains a large amount of dialectic data. Naturally, tweets are not sequential corpus as each tweet is independent and not affiliated with previous nor preceding text. Such data is important to build embedding models to represent dialects. We have collected 68,400,000 unique tweets using the standard Twitter API.

²<https://data.quora.com/First-Quora-Dataset-Release-Question-Pairs>

³<https://ai.mawdoo3.com/nsurl-2019-task8>

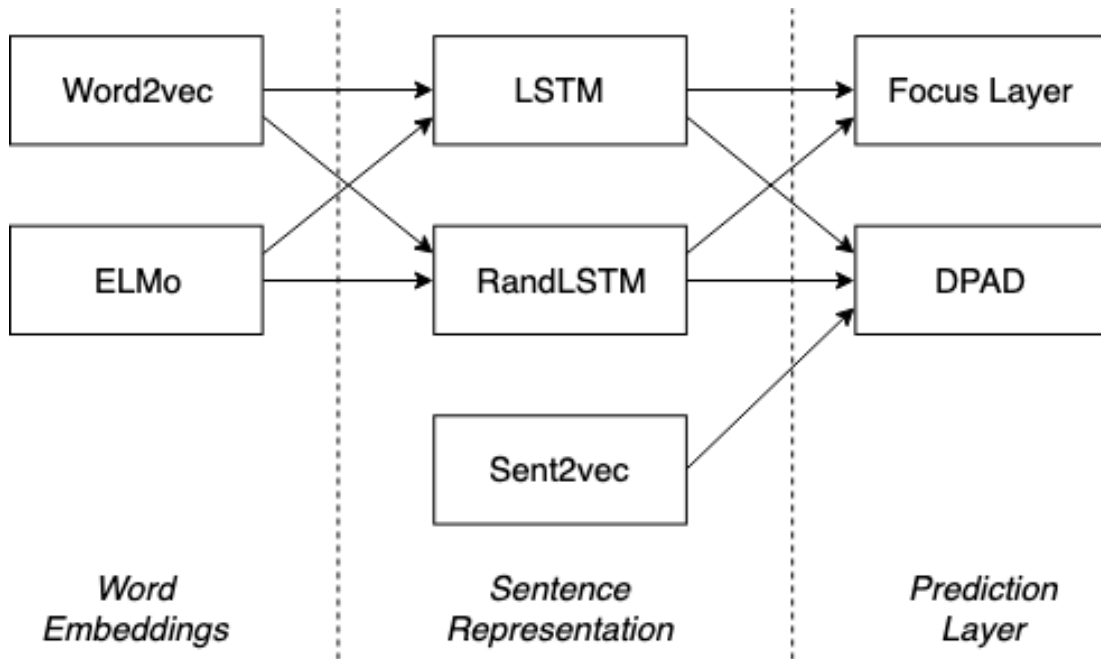

Figure 1: Building blocks of Q2Q network

Wikipedia⁴ is an encyclopedia of articles covering several topics. *Wikipedia.org* provides these articles for users to download. We have downloaded the articles written in MSA, cleaned them, and segmented them into sentences based on three punctuation marks, namely: {! ? .}. Segmenting the articles resulted in 4,600,000 sentences.

Mawdoo3⁵ is an encyclopedia providing articles in Arabic. Similar to Wikipedia articles, we obtained Mawdoo3 articles and segmented them resulting in 2,800,000 sentences.

To clean the data that we have collected from the three mentioned sources we follow AraVec approach for text normalization [7]. We combine all sentences in one dataset and use them to train our embedding models.

4 Models

There are diverse approaches with multiple flavors that can be applied to tackle the problem of Q2Q similarity. In our research, we identify machine learning blocks that can be utilized to build an end-to-end prediction model.

Figure 1 illustrates the building blocks, which are grouped into 3 main categories:

1. **Word Embeddings:** Converts a token into a vector representation that corresponds to its semantic meaning.
2. **Sentence Representation:** Either built on top of word embeddings or generated dependently (i.e., Sent2vec).
3. **Prediction Layer:** This layer consumes sentence embeddings from two different questions to output whether the questions are similar or not.

In the subsections below, we describe each machine learning block and where it fits in the pipeline.

4.1 Word2vec

Word2vec [22, 23] is a technique to learn continuous vector embeddings of words that represent the semantic meaning. These embeddings are learned using one of two ways, either using a group of words as context to predict a target word, a method known as Continuous Bag of Words (CBOW), or using a word to predict context words, which is known as skip-gram. By the end of the training phase, word vectors are projected in a high dimensional space such that similar

⁴www.wikipedia.com

⁵www.mawdoo3.com

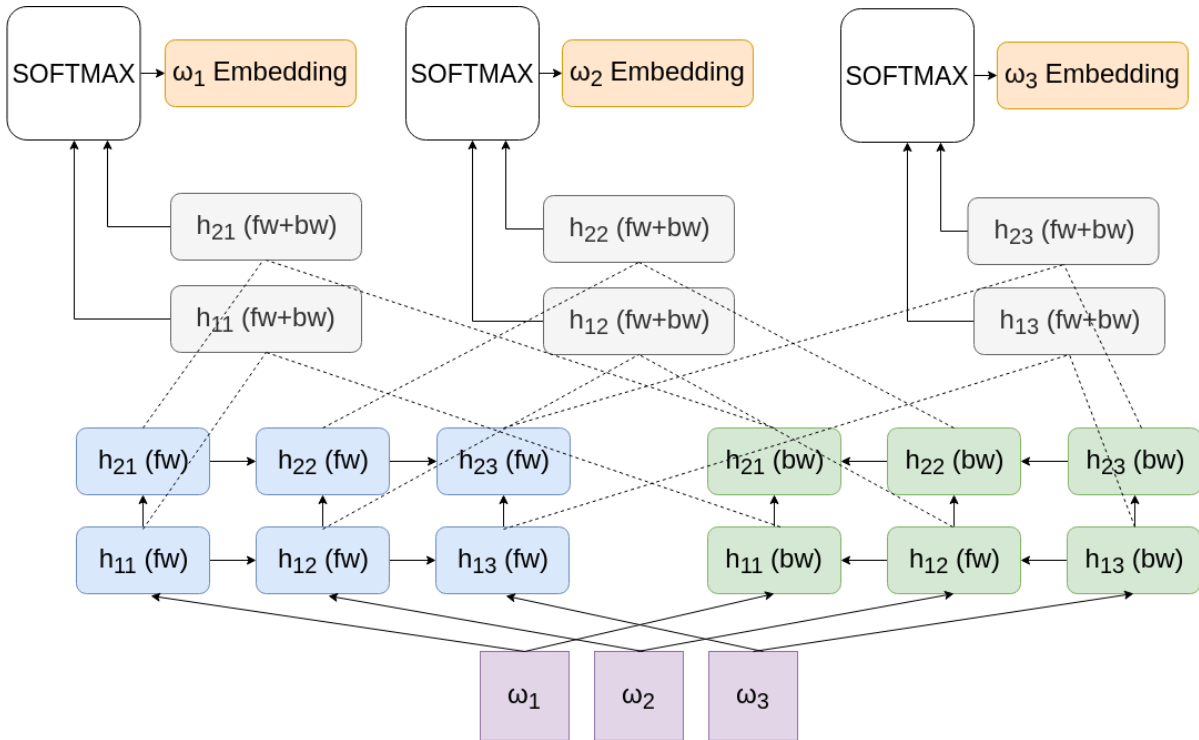

Figure 2: Illustration of the major components of an ELMO model

words that share common contexts are located close to each other. AraVec [7] is a widely-used pretrained Word2vec embedding model that is trained on Arabic tweets using CBOW method. We use AraVec in our Word2vec experiments.

4.2 ELMo

Despite the major advances in NLP brought about by dense vector representations of semantic units, it is not hard to see that it suffers from a few major drawbacks. One obvious shortcoming is that such representations fail to capture the different meanings that a given word might have (i.e. homonyms). For example, while the word “can” has different meanings depending on the context, they all get the same semantic representation. It can be readily seen how this might affect the performance of the downstream applications which build on these word embeddings.

The past few years have witnessed an increased amount of research directed to addressing this shortcoming, such as in [24–26]. ELMo (Embeddings from Language Models) [27] representations are among the most successful of these. As shown in Figure 2, these representations are obtained as a linear combination of the internal representations of the different layers of a bidirectional RNN language model. This can be thought of calculating the representations of any word in a given sentence, by conditioning on the whole sentence. The weighing of the contributions of each layer to the final representation, are fine-tuned per task. This allows the top layer machine learning algorithm to learn which of the signals from the various layers of the bidirectional language model are the most prevalent for its supervised learning task.

4.3 Trainable LSTM

This layer consumes a sequence of any word embedding type (i.e., Word2vec or ELMo) passing them into an LSTM [28] layer, one word embedding at each time step, and converts them into a thought vector. Thought vectors are a fixed sized array of numbers that represent the semantic meaning of the entire sentence, which is later consumed by a prediction layer. LSTM also computes an output vector for each time step which is compatible with another type of prediction layers.

4.4 RandLSTM

By using randomly initialized bidirectional LSTMs, to project pretrained word embeddings into a higher dimensional space, [29] were able to obtain very good results in sentence semantic similarity tasks. The LSTMs weights are sampled from the uniform distribution:

$$\left[\frac{1}{\sqrt{-d}}, \frac{1}{\sqrt{d}}\right] \quad (1)$$

where d represents the latent size of the given LSTM. The size d should be substantially larger than the size of the embedding space of the word representations used as input. This is based on the empirical evidence presented by the authors in their benchmark tests. It also builds on the observation made by [30], stating that for classification purposes, features that are projected into a high-dimensional space via some nonlinear method, has a better chance of being linearly separable than a corresponding lower dimensional projection, as long as the space is sparse in nature. The authors also note that the quality of the word representations used as the input, contributes the most to the performance obtained using such a configuration.

4.5 Sent2vec

Sent2vec [31] is an unsupervised model for sentence (not word) embeddings. The model computes the average of vectors of all words and n-grams in a sentence. Several studies have shown successful results produced by Sent2vec [32, 33]. The model learns a context embedding v_w and target embedding u_w for each word w in the vocabulary, with h number of embedding dimensions. The context words embeddings of a sentence, and its n-gram vectors, are averaged to get the sentence embeddings (v_S), as illustrated in Equation 2 [31].

$$v_S = \frac{1}{|R(S)|} \sum_{w \in R(S)} v_w, \quad (2)$$

where $R(S)$ is all the words and n-grams in sentence S .

4.6 Focus Layer

We adopt the work done by He *et al.*, [34]. Focus layer receives pair of questions, tokenize each pair into words, then for each token (word), we look for its similar word in the other question of the pair. If a match is found, then that word is considered important by the algorithm. This algorithm will capture a word in a question or sentence pair with its context, compare that with each word and its context in the other question or sentence pair with its context. The model consists of four components as follows:

4.6.1 Context modeling

A bidirectional LSTM (Bi-LSTM) is applied to the input embedding of each question in the pair. This allows the context to be represented in word vectors.

4.6.2 Pairwise word interaction modeling

The model will compare each word in a question with all words in the other question. Then compute a similarity measure on the hidden states of the LSTM that represent each word.

[34] has defined a similarity metric that consists of *cosine*, *dot product*, and L_2 *Euclidian distance* measures. All these measures are calculated between the hidden representations of each question of the pairs. The following Equation (Eq. 3) represents the similarity metric mathematically.

$$\text{sim}(\mathbf{h}_1, \mathbf{h}_2) = \{\cos(\mathbf{h}_1, \mathbf{h}_2), \|\mathbf{h}_1, \mathbf{h}_2\|, \langle \mathbf{h}_1, \mathbf{h}_2 \rangle\}, \quad (3)$$

where:

- \mathbf{h}_1 and \mathbf{h}_2 are the hidden states of the Bi-LSTM for question 1 and question 2, respectively .
- $\|\mathbf{h}_1, \mathbf{h}_2\|$ is L_2 Euclidian distance between \mathbf{h}_1 and \mathbf{h}_2
- $\langle \mathbf{h}_1, \mathbf{h}_2 \rangle$ is the inner (dot) product of \mathbf{h}_1 and \mathbf{h}_2

The output of this step is called *simCube* (or Similarity cube). A more detailed discussion on how the *simCube* is built can be found in [34]. Note that the *simCube* is built around the word contexts not the words themselves.

4.6.3 Focus layer

The core of this model is the focus layer that builds on top of the pairwise word interaction model and introduces re-weighting mechanism for the *simCube* model.

Since two types of similarity measures are used in Equation 3, namely, cosine and L_2 distance measures, the focus layer output (called *focusCube*) is computed over the two types of similarities. The computation aims to maximize the similarity for all word interactions computed in the *simCube*. The *focusCube* represents the final computation of the similarity score between words in the question pair.

4.6.4 ResNet

FocusCube converts Q2Q problem into pattern recognition problem, as such; a convNet of 19 layers has been used, followed by 2 fully connected layers, and a log-softmax layer as the final computation of the similarity score.

4.7 Dot Product & Absolute Distance (DPAD)

Similar to Focus layer, DPAD is one of the options for prediction layer at which we decide the similarity score and has been widely used in the literature [12, 31]. To predict the similarity between a pair of questions, first, we extract each question's thought vector using one of the sentence embedding methods. Then we apply two operations between the two vectors: (i) The absolute element-wise difference (ii) The element-wise multiplication. These operations result in two vectors. We concatenate them into one vector and feed it into logistic regression model, which predicts whether the two sentences are similar.

Figure 1 demonstrates how those building blocks are connected. It is worth noting that there is one invalid connection between *Sent2vec* and Focus layer. The reason for this is that Focus Layer compares array of vectors produced from each question. This array of vectors can be generated by LSTM cells, but *Sent2vec* can only compute one fixed-size thought vector per question.

There are nine different ways to connect those machine learning blocks. We build those models and train them with Mawdoo3 Q2Q dataset.

5 Experimental Setup

In this section, we demonstrate the effectiveness of our proposed approach. To conduct our experiments we have assembled models from the machine learning blocks discussed in Section 4. We compare these models to each other and to state-of-the-art baseline (described below). We claim that using Focus layer with ELMo embedding to predict Q2Q similarity boosts up the prediction accuracy and outperforms state-of-the-art approaches.

All experiments have been conducted on an Nvidia Tesla V100 GPU machine, with Ubuntu 16.04 as the operating system. All models, except for the Focus layer, are implemented with TensorFlow 1.12 [35] which is implemented using Pytorch 1.1 [36].

5.1 Baseline

Several studies have shown that using averaged word embedding vectors outperforms sophisticated LSTM-based sentence embeddings [31, 37]. Arora et al. [37] have proposed an approach called smooth inverse frequency (SIF) for generating sentence embeddings. We briefly describe it here. First, the weighted average of pre-trained word embedding vectors of the input sentence is calculated. The weights are computed using the frequency of words in training corpus. Frequent words get smaller weights than less frequent ones. Then the projection of the average vectors on their first singular vector is removed using SVD.

This approach has been widely used and has proven to be a strong baseline. We compute sentence embeddings for questions using this approach. We use AraVec as the pre-trained word vectors. Then we compute *DPAD* (as described in Section 4.7) to predict whether two questions are similar.

5.2 Trained Models

5.2.1 Baseline

To produce vectors using the baseline method, we use SIF implementation⁶. The weights of words are computed using the number of word occurrences in the training dataset. Following the authors approach [37], we set the weighting parameter to 0.001 and remove only one principle component. As mentioned above, we use AraVec pre-trained word embeddings.

5.2.2 ELMo

ELMo weights are trained on the text corpus discussed in Section 3.3. Then, for fine-tuning, we train ELMo connected to DPAD with Mawdoo3 Q2Q dataset. We set hyper-parameters configuration as shown in table 2. We have trained 64 sentences per batch, and each training epoch took around three minutes.

It is worth noting that BERT [26] is not part of our experiments. We can not train BERT with “Next Sentence Prediction” task because we do not have a continuous dialectic corpus. Tweets on the other hand is sufficient to train ELMo.

5.2.3 Sent2vec

To train our Sent2vec embedding model we use the package⁷ that is built on Facebook’s FastText library. We train the Sent2vec model of 300 dimensions using Negative Sampling loss function with negative samples set to 25. We did not specify a limit for the vocabulary size (i.e., maxVocabSize=None), however, we set the minimum number of a word occurrences (minCount) to 100 to eliminate uncommon typos in the dataset. The maximum length of word ngram is 2 and the number of epochs is 5. Similar to ELMo, Sent2vec is also trained on the text corpus collected from Mawdoo3, Wikipedia, and Twitter.

5.2.4 Focus layer

It is used in two settings: (i) Word2vec (ii) ELMo We set the hyper-parameter *hidden-units* to 256 for Word2vec, and 512 for ELMo. The other hyper-parameters are the same for both as shown in Table 2. We have trained the Focus layer for 20 epochs. On average, each epoch took around 90 seconds.

5.3 Results and Discussion

We compare the baseline with the nine different combinations composed from building blocks discussed in section 4. All models are trained with Mawdoo3 Q2Q training set and then evaluated against two different testing sets: Mawdoo3 Q2Q test set, and Madar Dialect Q2Q dataset. We report our F1 score results in table 1.

We first report the baseline, which achieves relatively high score on MSA test set with 0.72 F1 score but fails to generalize on dialectic test set scoring 0.42 F1 score, due to the fact that Word2vec works on word level and can not cope with Arabic language morphology. It can also be attributed to the small number of weights used in this approach.

The second trial is the Sent2vec combined with DPAD which is able to break the baseline on MSA (0.76 F1 score) but also fails to generalize on dialect dataset (0.36 F1 score) because, as in the baseline, Sent2vec neither emphasis on the morphology of the word as in ELMo nor has the number of learnable parameters that ELMo has.

Next we try Word2vec topped with LSTM layer, drastically increase the number of learnable weights, and DPAD prediction layer. The trainable LSTM layer boosts prediction for both MSA achieving 0.81 F1 score and 0.66 F1 score on dialectic test set. Formulating a thought vector from word embeddings is able to capture sentence semantics better than previous approaches. But this approach still suffers to generalize on dialects as the gap between both test sets is large, around 0.15 F1 score difference.

We test the impact of the focus layer by using it as a prediction layer instead of DPAD. As expected, adding a pairwise word similarity sub-network improves the performance of our model on MSA (0.84 F1 score). It is able to overcome word order transformations such as topicalization by finding patterns on word by word similarity scores to compute the final prediction. It is able to generalize better on dialectic test achieving 0.70 F1 score.

Next, we examine the impact of ELMo contextualized word embeddings by using it instead of Word2vec in all previous experiments. ELMo consistently improves accuracy in all combinations, which proves that our ELMo model, trained on

⁶<https://github.com/PrincetonML/SIF>

⁷<https://github.com/epfml/sent2vec>

Tweets, Arabic Wikipedia and Mawdoo3 articles, is better than AraVec and is able to capture semantic meaning more accurately. Arabic language is highly derivational language mutating many morphological variations [6] for each word, ELMo is able to capture sub-word embeddings such as root words, suffixes and prefixes generalized enough to project words accurately in all of its variations. In addition, ELMo can differentiate homonyms by projecting their embeddings based on their context.

Finally, we inspect the effect of replacing a trainable LSTM with random fixed LSTM. Trainable LSTM models have higher capacity to learn from the training dataset, hence it is expected to get higher scores than RandLSTM. But, it is interesting to note that when it is combined with focus layer, the gap between MSA and Dialect F1 scores is almost eliminated. We think that having fixed weighted LSTM acts as regularization mechanism for the trainable weights of the focus layer.

Experiments show that the best model for MSA Q2Q dataset is ELMo with trainable LSTM and DPAD, achieving an F1 score of 0.93. Unfortunately, this approach is not able to perform well on Madar Dialectic Q2Q as it is limited with thought vector. On the other hand, replacing DPAD with focus layer makes the solution robust across all test datasets, by getting 0.90 F1 on MSA and the highest score of 0.82 F1 score on Madar Dialectic Q2Q.

Throughout our experiments, it is clear to notice that focus layer is consistently making better predictions on Madar Dialectic Q2Q than DPAD. We calculate the average F1 difference between MSA and Dialectic for models using focus layer (0.073), then for models using DPAD (0.233). Having a deeper look into both test datasets, we notice that there are three main differences:

Sentence Lengths: Dialectic sentences are shorter in length. For example, MSA question:

أنا بحاجة إلى تذكرة؟

which means “Do I need a ticket?” contains four tokens, while the dialect version:

بححتاج تذكرة؟

has only two tokens. Hence, our model has to be capable of comparing long sentence (MSA) with shorter one (dialectic). Figure 3 shows the difference of question pair lengths in each dataset. The figure on the left is concerned with the difference of lengths between question 1 and question 2 in Mawdoo3 Q2Q dataset, as depicted, the question pairs are close in word count (length). On the other hand, it is clearly noticeable from the right-hand figure, the lengths of Madar Q2Q dataset question pairs have higher variance, yet the Focus Layer is still able to perform very well on this case.

Word Order: Written Questions are deep structured in which ambiguities do not exist and the semantic interpretation of a question is clear [38]. While dialectic questions are surface structured in which the sentence appears in speech. This means that our model has to overcome word order transformation to make a better predictions on dialect dataset.

Domain: MSA dataset is a collection of factoid questions whereas dialect dataset is conversational.

We attribute the success of focus layer by its ability to overcome sentence lengths and word order phenomena. Focus layer compares all combination of word representation instead of thought vectors, which enables it to search for similarities between words despite length and word order differences.

6 Conclusion and Future Work

Our major contribution is further generalizing Q2Q models trained on standard language into supporting different variations and domains of the same language. The approach combines ELMo, a character level contextualized word representation to overcome the high morphological nature of the Arabic language, and a focus layer, to handle the word order transformations that is induced by dialectic formatting or by the nature of the language itself.

We also provide the largest MSA Q2Q dataset and a procedure to generate Dialectic Q2Q dataset utilizing the MADAR parallel corpora for Arabic dialects.

As a future work, we would like to use computational linguistics approach as a text pre-processing layer to the question pair. For example, using lemmatization, morphological segmentation, syntactical parser as well as synonym expansion to the question pair.

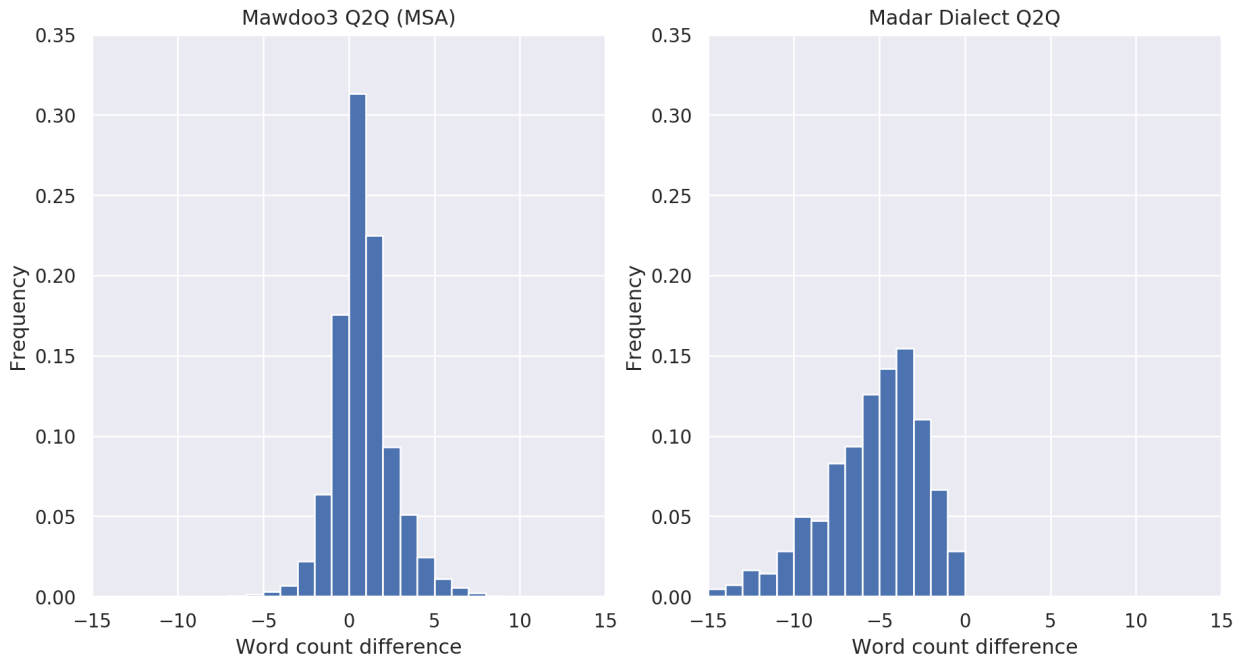

Figure 3: Distribution of question lengths (word count) difference between a pair in Mawdoo3 Q2Q dataset (MSA) and Madar Q2Q dataset (dialect). The figure on the left shows that the difference between question lengths of a pair in Mawdoo3 Q2Q dataset is small, varying 5 words at most, while the figure on the right, shows the difference between question lengths of Madar Q2Q dataset is significant, with the first question (MSA) has higher number of words than the second question (dialectic).

Table 1: F1 scores on the test sets (MSA and Dialectic Arabic). The training set is MSA. Best results are in bold. The combination of ELMo and FocusLayer boosts up the performance on Dialect, yielding better generalization

Model	MSA F1	Dialect F1
Baseline (Weighted Word2vec + DPAD)	0.72	0.42
Sent2vec + DPAD	0.76	0.36
Word2vec + TrainableLSTM + DPAD	0.81	0.66
Word2vec + RandLSTM + DPAD	0.62	0.44
Word2vec + TrainableLSTM + FocusLayer	0.84	0.70
Word2vec + RandLSTM + FocusLayer	0.72	0.69
ELMo + TrainableLSTM + DPAD	0.93	0.69
ELMo + RandLSTM + DPAD	0.83	0.47
ELMo + TrainableLSTM + FocusLayer	0.90	0.82
ELMo + RandLSTM + FocusLayer	0.75	0.71

Table 2: Summary of Training Hyper-parameters for each model

Model	hyper-params
ELMo	{bidirectional: true, batch-size: 128, lstm: {cell-clip: 3, proj-clip: 3, dim: 4096,projection-dim: 512, use-skip-connections: true, n-layers: 2}, n-negative-samples-batch: 8192, n-tokens-vocab: 6692, dropout: 0.1, n-epochs: 10, all-clip-norm_val: 10.0, char-cnn: {embedding: {dim: 16}},max-characters-per-token: 50, activation: relu, n-highway: 2, n-characters: 262 }
FocusLayer	{regularization: 0.00005, optimizer: adam, batch-size: 128, learn-rate: 0.00005, hidden-units: 512, res-layers: 19, res-fmaps: 32, epsilon: 1e-8}
Sent2vec	{mincount = 100, dim = 300, loss = neg(25) }
RandSent	{out-dim:4096,max-seq-len:96,pooling:max,n-layers:1,projection:same }

References

- [1] Yinfei Yang, Steve Yuan, Daniel Cer, Sheng-yi Kong, Noah Constant, Petr Pilar, Heming Ge, Yun-Hsuan Sung, Brian Strope, and Ray Kurzweil. Learning semantic textual similarity from conversations. *arXiv preprint arXiv:1804.07754*, 2018.
- [2] Daniel Cer, Yinfei Yang, Sheng-yi Kong, Nan Hua, Nicole Limtiaco, Rhomni St John, Noah Constant, Mario Guajardo-Cespedes, Steve Yuan, Chris Tar, et al. Universal sentence encoder. *arXiv preprint arXiv:1803.11175*, 2018.
- [3] Marwah Alian and Arafat Awajan. Arabic semantic similarity approaches-review. In *2018 International Arab Conference on Information Technology (ACIT)*, pages 1–6. IEEE, 2018.
- [4] Mahmoud Al-Ayyoub, Aya Nuseir, Kholoud Alsmearat, Yaser Jararweh, and Brij Gupta. Deep learning for arabic nlp: A survey. *Journal of computational science*, 26:522–531, 2018.
- [5] Haitham Seelawi, Ahmad Mustafa, Al-Bataineh Hesham, Wael Farhan, and Hussein T. Al-Natsheh. NSURL-2019 task 8: Semantic question similarity in arabic. In *Proceedings of the first International Workshop on NLP Solutions for Under Resourced Languages, NSURL '19, Trento, Italy, September 2019*.
- [6] Nizar Habash, Fadhl Eryani, Salam Khalifa, Owen Rambow, Dana Abdulrahim, Alexander Erdmann, Reem Faraj, Wajdi Zaghouani, Houda Bouamor, Nasser Zalmout, et al. Unified guidelines and resources for arabic dialect orthography. In *Proceedings of the Eleventh International Conference on Language Resources and Evaluation (LREC-2018)*, 2018.
- [7] Abu Bakr Soliman, Kareem Eissa, and Samhaa R. El-Beltagy. Aravec: A set of arabic word embedding models for use in arabic nlp. *Procedia Computer Science*, 117:256 – 265, 2017. Arabic Computational Linguistics.
- [8] El Moatez Billah Nagoudi and Didier Schwab. Semantic similarity of arabic sentences with word embeddings. In *Proceedings of the Third Arabic Natural Language Processing Workshop, WANLP 2017@EACL, Valencia, Spain, April 3, 2017*, pages 18–24, 2017.
- [9] Tomas Mikolov, Kai Chen, Greg Corrado, and Jeffrey Dean. Efficient estimation of word representations in vector space. *arXiv preprint arXiv:1301.3781*, 2013.
- [10] Mohamed A Zahran, Ahmed Magooda, Ashraf Y Mahgoub, Hazem Raafat, Mohsen Rashwan, and Amir Atyia. Word representations in vector space and their applications for arabic. In *International Conference on Intelligent Text Processing and Computational Linguistics*, pages 430–443. Springer, 2015.
- [11] Daniel Cer, Mona Diab, Eneko Agirre, Inigo Lopez-Gazpio, and Lucia Specia. SemEval-2017 task 1: Semantic textual similarity-multilingual and cross-lingual focused evaluation. *arXiv preprint arXiv:1708.00055*, 2017.
- [12] Yang Shao. HCTI at SemEval-2017 task 1: Use convolutional neural network to evaluate semantic textual similarity. In *Proceedings of the 11th International Workshop on Semantic Evaluation (SemEval-2017)*, pages 130–133, 2017.
- [13] Po-Sen Huang, Xiaodong He, Jianfeng Gao, Li Deng, Alex Acero, and Larry Heck. Learning deep structured semantic models for web search using clickthrough data. In *Proceedings of the 22nd ACM international conference on Information & Knowledge Management*, pages 2333–2338. ACM, 2013.
- [14] Jeffrey Pennington, Richard Socher, and Christopher Manning. Glove: Global vectors for word representation. In *Proceedings of the 2014 conference on empirical methods in natural language processing (EMNLP)*, pages 1532–1543, 2014.
- [15] Yann LeCun, Patrick Haffner, Léon Bottou, and Yoshua Bengio. Object recognition with gradient-based learning. In *Shape, contour and grouping in computer vision*, pages 319–345. Springer, 1999.
- [16] Dominik Scherer, Andreas Müller, and Sven Behnke. Evaluation of pooling operations in convolutional architectures for object recognition. In *International conference on artificial neural networks*, pages 92–101. Springer, 2010.
- [17] Rana Aref Salama, Abdou Youssef, and Aly Fahmy. Morphological word embedding for arabic. *Procedia computer science*, 142:83–93, 2018.
- [18] Xiao Li and Qingsheng Li. Calculation of sentence semantic similarity based on syntactic structure. *Mathematical Problems in Engineering, Vol. 2015, Article ID 203475*, 2015, 2015.
- [19] Pranav Rajpurkar, Jian Zhang, Konstantin Lopyrev, and Percy Liang. Squad: 100, 000+ questions for machine comprehension of text. *CoRR*, abs/1606.05250, 2016.
- [20] Siva Reddy, Danqi Chen, and Christopher D. Manning. Coqa: A conversational question answering challenge. *CoRR*, abs/1808.07042, 2018.

- [21] Houda Bouamor, Nizar Habash, Mohammad Salameh, Wajdi Zaghouni, Owen Rambow, Dana Abdulrahim, Ossama Obeid, Salam Khalifa, Fadhil Eryani, Alexander Erdmann, et al. The madar arabic dialect corpus and lexicon. In *Proceedings of the Eleventh International Conference on Language Resources and Evaluation (LREC-2018)*, 2018.
- [22] Tomas Mikolov, Kai Chen, Greg Corrado, and Jeffrey Dean. Efficient estimation of word representations in vector space. In *1st International Conference on Learning Representations, ICLR 2013, Scottsdale, Arizona, USA, May 2-4, 2013, Workshop Track Proceedings*, 2013.
- [23] Tomas Mikolov, Ilya Sutskever, Kai Chen, Gregory S. Corrado, and Jeffrey Dean. Distributed representations of words and phrases and their compositionality. In *Advances in Neural Information Processing Systems 26: 27th Annual Conference on Neural Information Processing Systems 2013. Proceedings of a meeting held December 5-8, 2013, Lake Tahoe, Nevada, United States.*, pages 3111–3119, 2013.
- [24] Arvind Neelakantan, Jeevan Shankar, Alexandre Passos, and Andrew McCallum. Efficient non-parametric estimation of multiple embeddings per word in vector space. *arXiv preprint arXiv:1504.06654*, 2015.
- [25] Heeyoul Choi, Kyunghyun Cho, and Yoshua Bengio. Context-dependent word representation for neural machine translation. *Computer Speech & Language*, 45:149–160, 2017.
- [26] Jacob Devlin, Ming-Wei Chang, Kenton Lee, and Kristina Toutanova. Bert: Pre-training of deep bidirectional transformers for language understanding. *arXiv preprint arXiv:1810.04805*, 2018.
- [27] Matthew E Peters, Mark Neumann, Mohit Iyyer, Matt Gardner, Christopher Clark, Kenton Lee, and Luke Zettlemoyer. Deep contextualized word representations. *arXiv preprint arXiv:1802.05365*, 2018.
- [28] Sepp Hochreiter and Jürgen Schmidhuber. Long short-term memory. *Neural computation*, 9(8):1735–1780, 1997.
- [29] John Wieting and Douwe Kiela. No training required: Exploring random encoders for sentence classification. *arXiv preprint arXiv:1901.10444*, 2019.
- [30] Thomas M Cover. Geometrical and statistical properties of systems of linear inequalities with applications in pattern recognition. *IEEE transactions on electronic computers*, (3):326–334, 1965.
- [31] Matteo Pagliardini, Prakhar Gupta, and Martin Jaggi. Unsupervised Learning of Sentence Embeddings using Compositional n-Gram Features. In *NAACL 2018 - Conference of the North American Chapter of the Association for Computational Linguistics*, 2018.
- [32] John Wieting and Kevin Gimpel. ParaNMT-50M: Pushing the limits of paraphrastic sentence embeddings with millions of machine translations. In *Proceedings of the 56th Annual Meeting of the Association for Computational Linguistics (Volume 1: Long Papers)*, pages 451–462, Melbourne, Australia, July 2018. Association for Computational Linguistics.
- [33] Basant Agarwal, Heri Ramampiaro, Helge Langseth, and Massimiliano Ruocco. A deep network model for paraphrase detection in short text messages. *Information Processing & Management*, 54(6):922 – 937, 2018.
- [34] Hua He and Jimmy Lin. Pairwise word interaction modeling with deep neural networks for semantic similarity measurement. In *Proceedings of the 2016 Conference of the North American Chapter of the Association for Computational Linguistics: Human Language Technologies*, pages 937–948, San Diego, California, June 2016. Association for Computational Linguistics.
- [35] Martín Abadi, Paul Barham, Jianmin Chen, Zhifeng Chen, Andy Davis, Jeffrey Dean, Matthieu Devin, Sanjay Ghemawat, Geoffrey Irving, Michael Isard, et al. Tensorflow: A system for large-scale machine learning. In *12th {USENIX} Symposium on Operating Systems Design and Implementation ({OSDI} 16)*, pages 265–283, 2016.
- [36] Adam Paszke, Sam Gross, Soumith Chintala, and Gregory Chanan. Pytorch: Tensors and dynamic neural networks in python with strong gpu acceleration. *PyTorch: Tensors and dynamic neural networks in Python with strong GPU acceleration*, 6, 2017.
- [37] Sanjeev Arora, Yingyu Liang, and Tengyu Ma. A simple but tough-to-beat baseline for sentence embeddings. In *5th International Conference on Learning Representations, ICLR 2017, Toulon, France, April 24-26, 2017, Conference Track Proceedings*, 2017.
- [38] Noam Chomsky. *Deep structure, surface structure, and semantic interpretation*. Indiana University Linguistics Club, 1969.