

# An allocation scheme for estimating the reliability of a parallel-series system

Z. BENKAMRA <sup>1</sup>, M. TERBECHE <sup>2</sup> and M. TLEMCANI <sup>1,\*</sup>

<sup>1</sup> University Mohamed Boudiaf, L.A.A.R, Algeria

<sup>2</sup> University of Oran, Algeria

\* mounir.tlemcani@univ-pau.fr (M.Tlemcani)

## Abstract

We give a hybrid two stage design which can be useful to estimate the reliability of a parallel-series and/or by duality a series-parallel system, when the component reliabilities are unknown as well as the total numbers of units allowed to be tested in each subsystem. When a total sample size is fixed large, asymptotic optimality is proved systematically and validated *via* Monte Carlo simulation.

**Keywords.** Asymptotic optimality; Hybrid; Reliability; Parallel-series; Two stage design.

## 1 Introduction

In reliability engineering two crucial objectives are considered: (1) to maximize an estimate of system reliability and (2) to minimize the variance of the reliability estimate. Because system designers and users are risk-averse, they generally prefer the second objective which leads to a system design with a slightly lower reliability estimate but a lower variance of that estimate, (eg, [4]). It provides decision makers efficient rules compared to other designs which have a higher system reliability estimate, but with a high variability of that estimate. In the case of parallel-series and/or by duality series-parallel systems, the variance of the reliability estimate can be lowered by allocation of a fixed sample size (the number of observations or units tested in the system), while reliability estimate is obtained by testing components, see Berry [3]. Allocation schemes for estimation with cost,

see for example [3, 5, 7, 8, 10, 11], lead generally to a discrete optimization problem which can be solved sequentially using adaptive designs in a fixed or a Bayesian framework. Based on a decision theoretic approach, the authors seek to minimize either the variance or the Bayes risk associated to a squared error loss function. The problem of optimal reliability estimation reduces to a problem of optimal allocation of the sample sizes between Bernoulli populations. Such problems can be solved *via* dynamic programming but this technique becomes costly and intractable for complex systems. In the case of a two components series or parallel system, optimal procedures can be obtained and solved analytically when the coefficients of variation of the associated Bernoulli populations are known, cf. eg, [6, 8]. Unfortunately, the coefficients of variation are not known in practice since they depend themselves on the unknown components reliabilities of the system. In [9], the author has defined a sequential allocation scheme in the case of a series system and has shown its first order asymptotic optimality for large sample sizes with comparison to the balanced scheme. In [1], a reliability sequential schemes (R-SS) was applied successfully to parallel-series systems, when the total number of units to be tested in each subsystem was fixed. Recently, in [2], a two stage design for the same purpose was presented and shown to be asymptotically optimal when the subsystems sample sizes are fixed and large at the same order of the total sample size of the system. The problem considered in this paper is useful to estimate the reliability of a parallel-series and/or by duality a series-parallel system, when the components reliabilities are unknown as well as the total numbers of units allowed to be tested in each subsystem. This work improves the results in [2] by developing a hybrid two stage design to get a dynamic allocation between the sample sizes allowed for subsystems and those allowed for their components. For example, consider a parallel system of four components (1),(2),(3) and (4), with reliabilities 0.05, 0.1, 0.95 and 0.99, respectively, under the constraint that the total number of observations allowed is  $T = 100$ . Then, the sequential scheme given in [1] suggests to test, respectively, 10, 10, 28 and 52 units and produces a variance of the system reliability estimate equal  $10^{-7}$ , approximately. This is visibly better, compared to the balanced scheme which takes an allocation equal 25 in each component and produces a variance ten times greater then the former. The hybrid sequential scheme proposed in this paper is a tool to solve the same problem when the components are replaced by subsystems. More precisely, it combines the schemes developed for parallel and/or series systems in order to obtain approximately the best allocation at subsystems level as well as at components level.

In section 2, definitions and preliminary results are presented accompa-

nied by the proper two stage design for a parallel subsystem just as was defined in [2] and its asymptotic optimality is proved for a fixed and large sample size. In section 3, a parallel-series system is considered and it is shown that the variance of its reliability estimate has a lower bound independent of allocation. This leads, in section 4, to the main result of this paper which lies in the hybrid two stage algorithm and its asymptotic optimality for a fixed and large sample size allowed for the system. In section 5, the results are validated *via* Monte Carlo simulation and it is shown that our algorithm leads asymptotically to the best allocation scheme to reach the lower bound of the variance of the reliability estimate. The last section is reserved for conclusion and remarks.

## 2 Preliminary results

Consider a system  $S$  of  $n$  subsystems  $S_1, S_2, \dots, S_n$  connected in series, each subsystem  $S_j$  contains  $n_j$  components  $S_{1j}, S_{2j}, \dots, S_{n_jj}$  connected in parallel. The system should be referred as parallel-series system. Assume  $s$ -independence within and across populations, then the system reliability is

$$R = \prod_{j=1}^n R_j, \quad (1)$$

where

$$R_j = 1 - \prod_{i=1}^{n_j} (1 - R_{ij})$$

is the reliability of the parallel subsystem  $S_j$  and  $R_{ij}$  the reliability of component  $S_{ij}$ . An estimator of  $R$  is assumed to be the product of sample reliabilities

$$\hat{R} = \prod_{j=1}^n \hat{R}_j,$$

where

$$\hat{R}_j = 1 - \prod_{i=1}^{n_j} (1 - \hat{R}_{ij})$$

and  $\hat{R}_{ij}$  is the sample mean of functioning units in component  $S_{ij}$ ,

$$\hat{R}_{ij} = \frac{\sum_{l=1}^{M_{ij}} X_{ij}^{(l)}}{M_{ij}},$$

$\hat{R}_{ij}$  is used to estimate  $R_{ij}$  where  $M_{ij}$  is the sample size and  $X_{ij}^{(l)}$  is the binary outcome of the unit  $l$  in component  $S_{ij}$ . It should be pointed that a unit is not necessarily a physical object in a component, but it represents just a Bernoulli observation of the functioning/failure state of that component. Hence, for each subsystem  $S_j$ , one must allocate

$$T_j = \sum_{i=1}^{n_j} M_{ij}$$

units such that the estimated reliability of the system is based on a total sample size

$$T = \sum_{j=1}^n T_j$$

As in the series case, with the help of s-independence and the fact that a sample mean is an unbiased estimator of a Bernoulli parameter, see [1, 2, 4], the variance of the estimated reliability  $\hat{R}$  incurred by any allocation scheme can be obtained,

$$Var \left\{ \hat{R} \right\} = \prod_{j=1}^n \left( Var \left( \hat{R}_j \right) + R_j^2 \right) - \prod_{j=1}^n R_j^2, \quad (2)$$

where

$$Var \left\{ \hat{R}_j \right\} = (1 - R_j)^2 \left[ \prod_{i=1}^{n_j} \left( 1 + \frac{c_{ij}^{-2}}{M_{ij}} \right) - 1 \right] \quad (3)$$

is given as a function of the allocation numbers  $M_{ij}$  and the coefficients of variation of Bernoulli populations

$$c_{ij} = \sqrt{1/R_{ij} - 1}$$

We have found convenient to work with the equivalent expression of (3),

$$Var \left\{ \hat{R}_j \right\} = (1 - R_j)^2 \left[ \sum_{i=1}^{n_j} \frac{c_{ij}^{-2}}{M_{ij}} + F \left( \frac{c_{1j}^{-2}}{M_{1j}}, \dots, \frac{c_{n_j j}^{-2}}{M_{n_j j}} \right) \right],$$

where

$$F \left( \frac{c_{1j}^{-2}}{M_{1j}}, \dots, \frac{c_{n_j j}^{-2}}{M_{n_j j}} \right)$$

is a sum over all the products of at least two of its arguments.

The problem is to estimate  $R$  when components reliabilities are unknowns and a total number of  $T$  units must be tested in the system at components level. The aim is to minimize the variance of  $\hat{R}$ . Hence, the problem can be addressed by developing allocation schemes to select  $M_{ij}$ , the numbers of units to be tested in each component  $i$  in the subsystem  $j$ , under the constraint

$$\sum_{j=1}^n \sum_{i=1}^{n_j} M_{ij} = T, \quad (4)$$

such that the variance of  $\hat{R}$  is as small as possible. Reliability sequential schemes (R-SS) exist for the series, parallel or parallel-series configurations when the sample sizes  $T_j$  of the subsystems are fixed. Therefore, one can fully optimize the variance of  $\hat{R}$  just by applying the (R-SS) to find the best partition  $T_1, T_2, \dots, T_n$  of  $T$ . Unfortunately, a full sequential design can not be used in practice for large systems since the number of operations will growth dramatically. For this reason, we reasonably propose a hybrid two stage design which is shown to be asymptotically optimal when  $T$  is large.

### 2.1 Lower bound for the variance of the estimated reliability of the parallel subsystem $S_j$

For the asymptotic optimization of the variance of the estimated reliabilities, we make use of the well-known Lagrange's identity which can be written in the form:

Let  $a_i > 0$ ,  $N_i > 0$ , for  $i = 1, \dots, k$  and  $N = N_1 + \dots + N_k$ , then the following identity holds.

$$\sum_{i=1}^k \frac{a_i}{N_i} = N^{-1} \left[ \left( \sum_{i=1}^k \sqrt{a_i} \right)^2 + \sum_{i=1}^{k-1} \sum_{j=i+1}^k \frac{(N_i \sqrt{a_j} - N_j \sqrt{a_i})^2}{N_i N_j} \right] \quad (5)$$

**Proposition 1.** Denote by

$$Q_j = (1 - R_j)^2 T_j^{-1} \left( \sum_{i=1}^{n_j} c_{ij}^{-1} \right)^2 \quad (6)$$

then

$$\text{Var} \{ \hat{R}_j \} \geq Q_j$$

*Proof.* The proof is a direct consequence of the previous identity (5). Indeed

$$\begin{aligned}
\text{Var} \left\{ \hat{R}_j \right\} &= (1 - R_j)^2 T_j^{-1} \left( \sum_{i=1}^{n_j} c_{ij}^{-1} \right)^2 \\
&+ T_j^{-1} (1 - R_j)^2 \sum_{i=1}^{n_j-1} \sum_{k=i+1}^{n_j} \frac{\left( M_{ij} c_{kj}^{-1} - M_{kj} c_{ij}^{-1} \right)^2}{M_{ij} M_{kj}} \\
&+ (1 - R_j)^2 F \left( \frac{c_{1j}^{-2}}{M_{1j}}, \frac{c_{2j}^{-2}}{M_{2j}}, \dots, \frac{c_{n_j j}^{-2}}{M_{n_j j}} \right) \tag{7}
\end{aligned}$$

□

## 2.2 The two stage design for the parallel subsystem $S_j$

Following the expansion (7) and since  $F$  contains second order terms (see later), one gives interest to the numbers  $M_{ij}$  which minimize the expression

$$T_j^{-1} \sum_{i=1}^{n_j-1} \sum_{k=i+1}^{n_j} \frac{\left( M_{ij} c_{kj}^{-1} - M_{kj} c_{ij}^{-1} \right)^2}{M_{ij} M_{kj}}$$

Thus  $M_{ij}$  must verify for  $i = 1, \dots, n_j$

$$M_{ij} c_{kj}^{-1} = M_{kj} c_{ij}^{-1}$$

which implies that

$$M_{ij} = T_j \frac{c_{ij}^{-1}}{\sum_{k=1}^{n_j} c_{kj}^{-1}} \tag{8}$$

If one assumes that  $T_j$  is fixed then a proper two stage scheme can be used to determine  $M_{ij}$ , just as was defined in [2], as follows:

Choose  $L_j$  as a function of  $T_j$  such that:

- (i)  $L_j$  must be large if  $T_j$  is large,
- (ii)  $L_j \leq \frac{T_j}{n_j}$ ,
- (iii)  $\lim_{T_j \rightarrow \infty} \frac{L_j}{T_j} = 0$ .

One can take for example  $L_j = \lfloor \sqrt{T_j} \rfloor$ , where  $\lfloor \cdot \rfloor$  denotes the integer part.

**Stage 1.** Sample  $L_j$  units from each component  $i$  in the subsystem  $j$ , estimate  $c_{ij}$  by its maximum likelihood estimator (M.L.E)

$$\hat{c}_{ij} = \sqrt{\frac{L_j}{\sum_{l=1}^{L_j} X_{ij}^{(l)}} - 1}$$

and define the predictor, according to (8),

$$\hat{M}_{ij} = \left[ T_j \frac{\hat{c}_{ij}^{-1}}{n_j} \right]_{k=1}^{n_j-1}, \quad i = 1, \dots, n_j - 1$$

**Stage 2.** Sample  $T_j - n_j L_j$  units for which  $M_{ij} - L_j$  are units from component  $i$  in the subsystem  $j$  where  $M_{ij}$  is the corrector of  $\hat{M}_{ij}$  defined by

$$M_{ij} = \max \left\{ L_j, \hat{M}_{ij} \right\}, \quad i = 1, \dots, n_j - 1,$$

$$M_{n_j j} = T_j - \sum_{k=1}^{n_j-1} M_{kj}$$

**Theorem 1.** *Choosing the  $M_{ij}$  according to the previous two stage sampling scheme, one obtains*

$$\lim_{T_j \rightarrow \infty} T_j \left( \text{Var} \left\{ \hat{R}_j \right\} - Q_j \right) = 0$$

*Proof.* From relation (7), one can write

$$T_j \left( \text{Var} \left\{ \hat{R}_j \right\} - Q_j \right) = (1 - R_j)^2 \sum_{i=1}^{n_j-1} \sum_{k=i+1}^{n_j} \frac{\left( M_{ij} c_{kj}^{-1} - M_{kj} c_{ij}^{-1} \right)^2}{M_{ij} M_{kj}}$$

$$+ (1 - R_j)^2 T_j \cdot F \left( \frac{c_{1j}^{-2}}{M_{1j}}, \dots, \frac{c_{n_j j}^{-2}}{M_{n_j j}} \right) \quad (9)$$

When  $T_j$  is large enough, condition (iii) gives  $M_{ij} = \hat{M}_{ij}$  for  $i = 1, \dots, n_j - 1$ . So, the strong law of large numbers with the integer part properties give, when  $T_j \rightarrow \infty$ ,

$$\frac{M_{ij}}{M_{kj}} \rightarrow \frac{c_{kj}}{c_{ij}},$$

for  $i = 1, \dots, n_j$ . Hence,

$$\frac{\left(M_{ij}c_{kj}^{-1} - M_{kj}c_{ij}^{-1}\right)^2}{M_{ij}M_{kj}} = \frac{M_{ij}}{M_{kj}} \left(c_{kj}^{-1} - \frac{M_{kj}}{M_{ij}}c_{ij}^{-1}\right)^2 \rightarrow 0, \text{ as } T_j \rightarrow \infty, \quad (10)$$

and on the other hand

$$T_j.F \left( \frac{c_{1j}^{-2}}{M_{1j}}, \dots, \frac{c_{n_j j}^{-2}}{M_{n_j j}} \right) \rightarrow 0, \text{ as } T_j \rightarrow \infty, \quad (11)$$

which achieves the proof.  $\square$

### 3 Lower bound for the variance of the estimated reliability of the parallel-series system

We consider now the parallel-series system  $S$ . From expression (2), one can write

$$\text{Var} \{ \hat{R} \} = R^2 \left[ \prod_{j=1}^n \left( \frac{\text{Var}(\hat{R}_j)}{R_j^2} + 1 \right) - 1 \right]$$

The following theorem gives a lower bound for the variance of  $\hat{R}$ .

**Theorem 2.** Denote by

$$Q = T^{-1}R^2 \left[ \sum_{j=1}^n \frac{1-R_j}{R_j} \left( \sum_{i=1}^{n_j} c_{ij}^{-1} \right) \right]^2$$

then

$$\text{Var} \{ \hat{R} \} \geq Q$$

*Proof.* Expanding the right hand side of (2) and using (1), one obtains

$$\text{Var} \{ \hat{R} \} = R^2 \left[ \sum_{j=1}^n \frac{\text{Var}(\hat{R}_j)}{R_j^2} + F \left( \frac{\text{Var}(\hat{R}_1)}{R_1^2}, \dots, \frac{\text{Var}(\hat{R}_n)}{R_n^2} \right) \right],$$

which gives with the help of Theorem 1

$$\text{Var} \{ \hat{R} \} \geq R^2 \sum_{j=1}^n \frac{Q_j}{R_j^2} = R^2 \sum_{j=1}^n \frac{\left( \frac{1-R_j}{R_j} \sum_{i=1}^{n_j} c_{ij}^{-1} \right)^2}{T_j} \quad (12)$$



This last expression has the form

$$R^2 \sum_{j=1}^n \frac{a_j}{T_j}$$

which can be expanded, thanks to identity (5), as follows

$$\begin{aligned} & R^2 T^{-1} \left[ \sum_{j=1}^n \frac{1-R_j}{R_j} \left( \sum_{k=1}^{n_j} c_{kj}^{-1} \right) \right]^2 \\ + & R^2 T^{-1} \sum_{i=1}^{n-1} \sum_{j=i+1}^n \frac{\left( T_i \frac{1-R_j}{R_j} \sum_{k=1}^{n_j} c_{kj}^{-1} - T_j \frac{1-R_i}{R_i} \sum_{k=1}^{n_i} c_{ki}^{-1} \right)^2}{T_i T_j} \end{aligned} \quad (13)$$

and as a consequence

$$\text{Var} \{ \hat{R} \} \geq T^{-1} R^2 \left[ \sum_{j=1}^n \frac{1-R_j}{R_j} \left( \sum_{k=1}^{n_j} c_{kj}^{-1} \right) \right]^2 = Q,$$

which achieves the proof.  $\square$

## 4 The hybrid two stage design for the parallel-series system $S$

Similarly to the case of a subsystem an from expressions (12) and (13), one gives interest to the numbers  $T_j$  which minimize the quantity

$$\sum_{i=1}^{n-1} \sum_{j=i+1}^n \frac{\left( T_i \frac{1-R_j}{R_j} \sum_{k=1}^{n_j} c_{kj}^{-1} - T_j \frac{1-R_i}{R_i} \sum_{k=1}^{n_i} c_{ki}^{-1} \right)^2}{T_i T_j},$$

and obtains the asymptotic optimality criteria

$$\frac{T_i}{T_j} = \frac{\frac{1-R_i}{R_i} \sum_{k=1}^{n_i} c_{ki}^{-1}}{\frac{1-R_j}{R_j} \sum_{k=1}^{n_j} c_{kj}^{-1}},$$

for all  $i, j \in \{1, 2, \dots, n\}$ , which gives the rule

$$T_j = T \frac{\frac{1-R_j}{R_j} \sum_{k=1}^{n_j} c_{kj}^{-1}}{\sum_{k=1}^n \frac{1-R_k}{R_k} \sum_{i=1}^{n_k} c_{ik}^{-1}} \quad (14)$$

We can now implement a hybrid two stage design for the determination of the numbers  $T_j$  as well as  $M_{ij}$  as follows:

**Stage 1** choose  $L = \lceil \sqrt{T} \rceil$ : one applies the two stage scheme given in subsection 2.1 for each subsystem  $S_j$  with  $T_j = L$  and  $L_j = \lceil \sqrt{T_j} \rceil$ . Next, obtain the predictor, according to the rule (14),

$$\hat{T}_j = \left[ T \frac{\frac{1-\hat{R}_j}{\hat{R}_j} \sum_{k=1}^{n_j} \hat{c}_{kj}^{-1}}{\sum_{k=1}^n \frac{1-\hat{R}_k}{\hat{R}_k} \sum_{i=1}^{n_k} \hat{c}_{ik}^{-1}} \right], \quad j = 1, \dots, n-1.$$

**Stage 2** define the corrector

$$\begin{aligned} T_j &= \max \left\{ L, \hat{T}_j \right\}, \quad j = 1, \dots, n-1, \\ T_n &= T - \sum_{j=1}^{n-1} T_j, \end{aligned}$$

and take back the two stage scheme for each subsystem  $S_j$  to calculate  $M_{ij}$  with the sample size equals  $T_j$ .

Now, the main result of this paper is given by the following theorem.

**Theorem 3.** *Choosing the  $T_j$  and  $M_{ij}$  according to the hybrid two stage design, one obtains*

$$\lim_{T \rightarrow \infty} T \left( \text{Var} \left\{ \hat{R} \right\} - Q \right) = 0,$$

where  $Q$  is defined in Theorem 2.

*Proof.* The relation (9) implies that

$$\begin{aligned} \text{Var} \left\{ \hat{R}_j \right\} &= Q_j + T_j^{-1} (1 - R_j)^2 \sum_{i=1}^{n_j-1} \sum_{k=i+1}^{n_j} \frac{(M_{ij} c_{kj}^{-1} - M_{kj} c_{ij}^{-1})^2}{M_{ij} M_{kj}} \\ &\quad + (1 - R_j)^2 F \left( \frac{c_{1j}^{-2}}{M_{1j}}, \dots, \frac{c_{n_j j}^{-2}}{M_{n_j j}} \right) \end{aligned}$$

As a consequence of the hybrid two stage design and the strong law of large numbers,  $T/T_j$  and  $T_j/M_{ij}$  remain bounded for all  $i, j$  as  $T \rightarrow \infty$ . It follows that, as  $T \rightarrow \infty$ ,

$$F\left(\frac{c_{1j}^{-2}}{M_{1j}}, \dots, \frac{c_{n_j j}^{-2}}{M_{n_j j}}\right) = o(T^{-1}),$$

and

$$T_j^{-1} \sum_{i=1}^{n_j-1} \sum_{k=i+1}^{n_j} \frac{(M_{ij}c_{kj}^{-1} - M_{kj}c_{ij}^{-1})^2}{M_{ij}M_{kj}} = o(T^{-1}),$$

thanks to (10) and (11). Thus,

$$\text{Var}\{\hat{R}_j\} = Q_j + o(T^{-1}), \text{ as } T \rightarrow \infty,$$

which implies that

$$\begin{aligned} \prod_{j=1}^n \left( \frac{\text{Var}\{\hat{R}_j\}}{R_j^2} + 1 \right) &= \prod_{j=1}^n \left( \frac{Q_j}{R_j^2} + 1 + o(T^{-1}) \right) \\ &= \prod_{j=1}^n \left( \frac{Q_j}{R_j^2} + 1 \right) + o(T^{-1}) \end{aligned}$$

As a consequence,

$$\lim_{T \rightarrow \infty} T \left( \text{Var}\{\hat{R}\} - Q \right) = R^2 \lim_{T \rightarrow \infty} T \cdot \left[ \prod_{j=1}^n \left( \frac{Q_j}{R_j^2} + 1 \right) - 1 - Q \right]$$

Now, expanding the product within the limit and applying identity (5), after having replaced  $Q_j$  by its expression (6), one obtains

$$\begin{aligned} \prod_{j=1}^n \left( \frac{Q_j}{R_j^2} + 1 \right) - 1 &= R^2 \left[ \sum_{j=1}^n \frac{Q_j}{R_j^2} + F\left(\frac{Q_1}{R_1^2}, \dots, \frac{Q_n}{R_n^2}\right) \right] \\ &= Q + R^2(A + B), \end{aligned}$$

where

$$\begin{aligned} A &= T^{-1} \sum_{i=1}^{n-1} \sum_{k=i+1}^n \frac{\left( T_i \left( \frac{1-R_k}{R_k} \right) \left( \sum_{l=1}^{n_k} c_{lk}^{-1} \right) - T_k \left( \frac{1-R_i}{R_i} \right) \left( \sum_{l=1}^{n_k} c_{li}^{-1} \right) \right)^2}{T_i T_k} \\ B &= F\left(\frac{Q_1}{R_1^2}, \dots, \frac{Q_n}{R_n^2}\right) \end{aligned}$$

Once more, the hybrid two stage allocation scheme and the strong law of large numbers provide

$$\lim_{T \rightarrow \infty} T.A = 0$$

and

$$\lim_{T \rightarrow \infty} T.B = 0,$$

which achieves the proof.  $\square$

## 5 Monte Carlo simulation

Let us remark first that the lower bound  $Q$  is a first order approximation of the optimal variance of the reliability estimate under the constraint (4) when  $T$  is large.

In the first experiment, we will validate the fact that the hybrid scheme provides the best allocation at system level. As in Figure 1, we consider a simple parallel-series system of two subsystems each one, with varying reliabilities and a fixed sample size  $T = 20$ . For each situation A,B,C and D and for each partition sample size  $\{T_1, T - T_1\}$  where  $T_1$  varies from  $\lceil \sqrt{T} \rceil$  to  $T - \lceil \sqrt{T} \rceil$ , by step one, we have applied the proper two stage design for each parallel subsystem and reported in a bar diagram  $Var(\hat{R})$  as a function of  $T_1$ , see Figure 3. On the other hand, in Table 1, we have reported the expected value of  $T_1 = M_{11} + M_{21}$  given by the hybrid two stage design. As expected, our scheme gives the best allocation for each situation.

The second experiment deals with a non trivial parallel-series system just as in [2], where subsystems are composed, respectively, of 2,3,4 and 5 components, see Figure 2. The partition total numbers  $T_j$  to test in each subsystem are evaluated systematically by the hybrid two stage design while their sum  $T$  is incremented from 100 to 10000 by step of 100. Figure 4 shows the rate of the excess of variance  $T(Var(\hat{R}) - Q)$  at logarithmic scale as a function of the sample size  $T$ . The asymptotic optimality of the hybrid scheme is validated.

## 6 Conclusion

The proof of the first order asymptotic optimality for the proper two stage design for a parallel subsystem as well as for the hybrid two stage design for the full system has been obtained mainly through the following steps

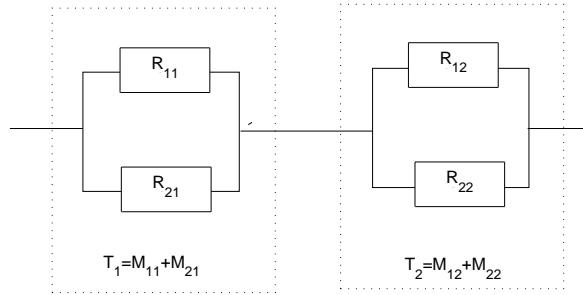

Figure 1: A simple parallel-series system of two subsystems with two components each one

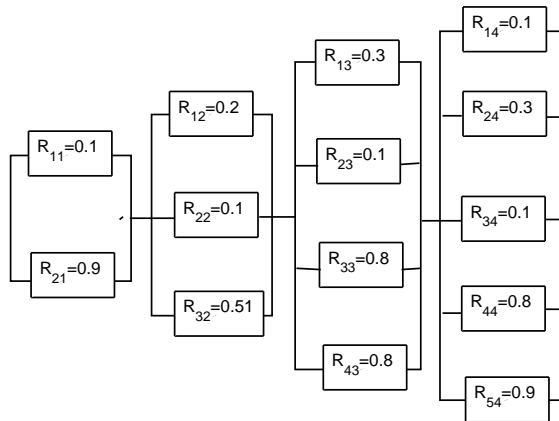

Figure 2: A non trivial parallel-series system.

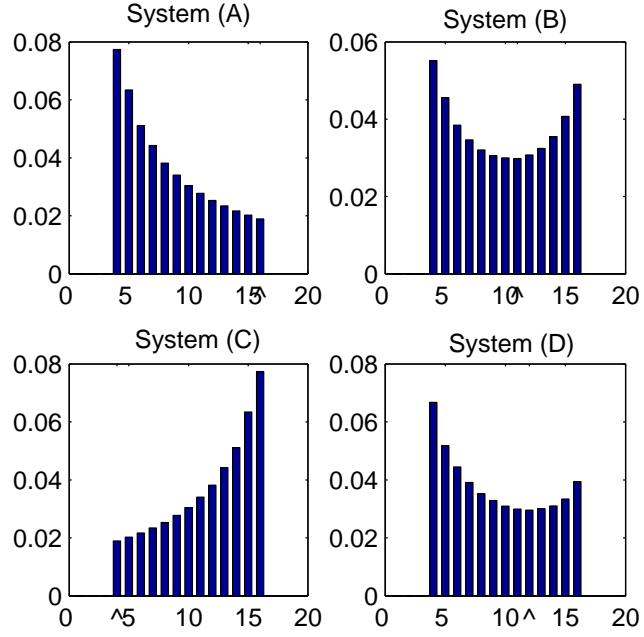

Figure 3: Bar diagram  $Var(\hat{R})$  as a function of  $T_1$  for each case A,B,C and D :  $\hat{\cdot}$  shows the minimum of  $Var(\hat{R})$

System	$R_{11}$	$R_{21}$	$R_{12}$	$R_{22}$	$E(T_1)$
A	0.1	0.11	0.9	0.99	16
B	0.5	0.55	0.51	0.6	11
C	0.9	0.99	0.1	0.11	4
D	0.2	0.4	0.6	0.3	12

Table 1: Expected value of  $T_1 = M_{11} + M_{21}$  given by the hybrid two stage design

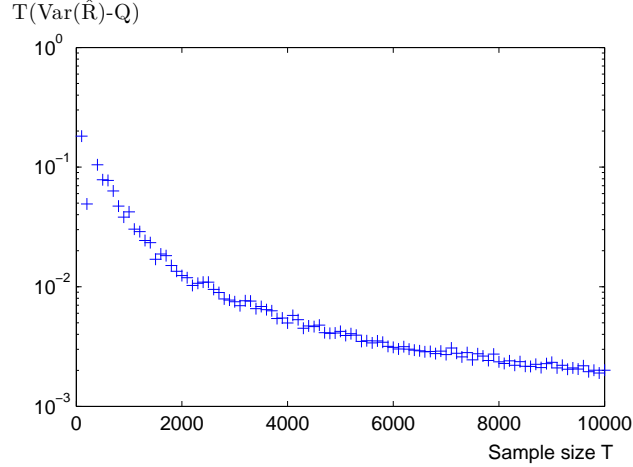

Figure 4: Asymptotic optimality of the hybrid two stage design : the speed of the excess of variance  $T \left( Var \left( \hat{R} \right) - Q \right)$  at logarithmic scale as a function of the sample size  $T$

- an adequate writing of the variance of the reliability estimate,
- a lower bound for this variance, independent of allocation,
- the allocation defined by the hybrid sampling scheme and the strong law of large numbers.

With a straightforward but tedious adaptation, the above study can be namely extended to deal with complex systems involving a multi-criteria optimization problem under a set of constraints such as risk, system weight, cost, performance and others, in a fixed or in a Bayesian framework.

## Acknowledgments

This work is supported with grants by the national research project (PNR) and the L.A.A.R laboratory of the department of physics in the university Mohamed Boudiaf of Oran.

## References

- [1] Z. Benkamra, M. Terbeche, M. Tlemcani, Procédures d'échantillonnage efficaces. Estimation de la fiabilité des systèmes séries/parallèles, *Revue ARIMA*, 13 (2010) 119–133.
- [2] Z. Benkamra, M. Terbeche, M. Tlemcani, Tow stage design for estimating the reliability of series/parallel systems, *Mathematics and Computer in Simulation* 81 (2011) 2062–2072.
- [3] D. A. Berry, Optimal sampling schemes for estimating System reliability by testing components –1 : fixed sample sizes. *Journal of the American Statistical Association* 69(346) (1974) 485–491.
- [4] D. W. Coit, System-reliability confidence-intervals for complex-systems with estimated component-reliability, *IEEE Transactions on Reliability*, 46 (4) (1997) 487–493.
- [5] M. Djerdjour, K. Rekab, A sampling scheme for reliability estimation, *Southwest Journal of Pure and Applied Mathematics*, electronic(2) (2002) 1–5.
- [6] J. P. Hardwick, Q.F. Stout, Optimal allocation for estimating the mean of a bivariate polynomial, *Sequential Analysis*, 15 (1996) 71–90.
- [7] J. P. Hardwick, Q.F. Stout, Optimal few-stage designs, *Journal of Statistical Planning and Inference* 104 (2002) 121-145.
- [8] C.F. Page, Allocation proportional to coefficients of variation when estimating the product of parameters, *Journal of the American Statistical Association* 85 (412) (1990) 1134–1139.
- [9] K. Rekab, A sampling scheme for estimating the reliability of a series system, *IEEE Trans. Reliability* 42(2) (1993), pp. 287–290.
- [10] M. Terbeche, O. Broderick, Two stage design for estimation of mean difference in the exponential family, *Advances and Applications in Statistics* 5(3) (2005) 325–339.
- [11] M. Woodroffe, J. Hardwick, Sequential allocation for an estimation problem with ethical costs, *Annals of Statistics* 18(3) (1990) 1358–1377.