

1 **Characterization of a novel angular dioxygenase from fluorene-degrading**
2 ***Sphingomonas* sp. strain LB126**

3 Luc Schuler¹, Sinéad M. Ní Chadhain², Yves Jouanneau³, Christine Meyer³, Gerben J.
4 Zylstra², Pascal Hols⁴ and Spiros N. Agathos^{1* §}

5
6 ¹ Unité de Génie Biologique, Institut des Sciences de la Vie, Université catholique de
7 Louvain, Place Croix du Sud, 2/19, B-1348 Louvain-la-Neuve, Belgium.

8 ² Biotechnology Center for Agriculture and the Environment, Cook College, Rutgers
9 University, New Brunswick, New Jersey, USA.

10 ³ Laboratoire de Chimie et Biologie des Métaux, iRTSV, CEA, CNRS, Université J. Fourier
11 UMR 5249, CEA-Grenoble, F-38054 Grenoble Cedex 9, France.

12 ⁴ Unité de Génétique, Institut des Sciences de la Vie, Université catholique de Louvain, Place
13 Croix du Sud 5, B-1348 Louvain-la-Neuve, Belgium.

14 **Running Title:** Angular dioxygenase from *Sphingomonas* sp. LB126

15 **Keywords:** Bioremediation, catabolic gene cluster, polycyclic aromatic hydrocarbons,
16 heterologous expression

17 * Corresponding author.

18 Mailing address: Unité de Génie Biologique,
19 Institut des Sciences de la Vie,
20 Université catholique de Louvain,
21 Place Croix du Sud, 2/19,
22 B-1348 Louvain-la-Neuve, Belgium.

23 Phone: +32 10 47 36 44.

24 Fax: 32 10 47 30 62.

25 E-mail: spiros.agathos@uclouvain.be

26

ABSTRACT

27 In this study, the genes involved in the initial attack on fluorene by *Sphingomonas* sp. LB126
28 were investigated. The α and β subunits of a dioxygenase complex (FlnA1A2), showing 63%
29 and 51% sequence identity respectively, with the subunits of an angular dioxygenase from
30 Gram-positive *Terrabacter* sp. DBF63, were identified. When overexpressed in *E. coli*,
31 FlnA1A2 was responsible for the angular oxidation of fluorene, fluorenol, fluorenone,
32 dibenzofuran and dibenzo-*p*-dioxin. Moreover, FlnA1A2 was able to oxidize polycyclic
33 aromatic hydrocarbons and heteroaromatics, some of which were not oxidized by the
34 dioxygenase from *Terrabacter* sp. DBF63. Quantification of resulting oxidation products
35 showed that fluorene and phenanthrene were preferred substrates.

36

INTRODUCTION

37
38 Polycyclic aromatic hydrocarbons (PAHs) are ubiquitous environmental contaminants and are
39 formed during the burning, handling or disposal of organic matter including coal tars, crude
40 oil and petroleum products. There are some natural origins, such as forest fires or natural oil
41 seeps, but PAHs mainly arise from combustion- or oil-related anthropogenic activities. A
42 number of organisms that are able to use PAHs as sole source of carbon and energy have been
43 isolated (6) and bioremediation strategies using these organisms have been proposed (17).

44
45 Fluorene, a tricyclic aromatic hydrocarbon containing a five-membered ring, offers a variety
46 of possibilities for biochemical attack. Two of these pathways are initiated by a dioxygenation
47 at the 1,2- (5, 9) or 3,4- positions (5, 10, 27) (Fig. 1). The corresponding *cis*-dihydrodiols
48 undergo dehydrogenation, then *meta*-cleavage. The third route (39, 45) is initiated by
49 monooxygenation at the C-9 position to give 9-fluorenol, which is then dehydrogenated to 9-
50 fluorenone. This route is only productive if a subsequent angular carbon dioxygenation forms
51 1-hydro-1,1a-dihydroxy-9-fluorenone, leading to phthalate, which is degraded in turn via
52 protocatechuate (11, 27, 45) (Fig. 1).

53
54 Sphingomonads have been intensively studied for their ability to degrade a wide range of
55 aromatic hydrocarbons (32, 34, 42, 43, 49, 50). The function and organization of catabolic
56 genes often remain obscure since the genes involved in the degradation of aromatic
57 compounds are not always arranged in discrete operons but are frequently dispersed
58 throughout the genome. *Sphingomonas* sp. LB126 was isolated from PAH contaminated soil
59 and is capable of utilizing fluorene as sole carbon source (3). Fluorene degradation by strain
60 LB126 has been previously investigated (48), but the enzymes that govern the initial attack on
61 fluorene were not identified.

62 Habe et al. (13, 14) showed that the Gram-positive dibenzofuran degrading bacterium
63 *Terrabacter* sp. DBF63, can also oxidize fluorene thanks to a cluster of plasmid-borne
64 catabolic genes. The oxygenase component of an angular dioxygenase complex, encoded by
65 *dbfA1A2*, does not cluster with already known dioxygenases. Few data are available regarding
66 genes involved in fluorene degradation by Gram-negative bacteria. Although many PAH
67 dioxygenases are known to oxidize fluorene, the respective strains could not use fluorene as
68 sole carbon source. Recently, the catabolic plasmid pCAR3 from *Sphingomonas* sp. KA1 was
69 described (41). Genes homologous to *dbfA1A2* were found on pCAR3, as well as all genes
70 necessary for the complete degradation of fluorene, but strain KA1 is unable to grow on
71 fluorene as sole source of carbon. We present here the first report, to our knowledge, of genes
72 governing angular attack on fluorene in Gram-negative bacteria using fluorene as the sole
73 source of carbon and energy.

74

75

MATERIALS AND METHODS

76 **Bacterial strains, plasmids, and media.** *Sphingomonas* sp. LB126, the wild-type strain
77 capable of growing on fluorene as the sole source of carbon and energy (3), was kindly
78 provided by VITO (Vlaamse Instelling voor Technologisch Onderzoek, Belgium).
79 *Escherichia coli* Top10 was used as the recipient strain in all cloning experiments. *E. coli*
80 BL21(DE3) was used for gene expression analysis. PCR amplicons were either cloned into
81 pDrive (Qiagen, Valencia, CA) or pGEM-T-easy vector (Promega, Madison, WI), and
82 pET30f (Novagen, San Diego, CA) was used as expression vector. MM284 minimal medium
83 (26) was used for growing *Sphingomonas* sp. LB126 and was supplemented with phosphate
84 buffer (0.5 M KH_2PO_4 , 0.5 M K_2HPO_4 , pH 7.2) instead of Tris buffer. Fluorene was provided
85 as crystals in both Petri dishes and liquid media. LB broth (37) was used as complete medium
86 for growing *E. coli* strains. Solid media contained 2% agar. When needed, ampicillin,
87 streptomycin or kanamycin were added to the medium at 100, 200 and 20 $\mu\text{g}/\text{ml}$, respectively.
88 *Sphingomonas* sp. LB126 was grown at 30°C, and *E. coli* strains were grown at 37°C.
89 Bacterial growth was determined by optical density readings at 600 nm (OD_{600}).

90

91 **DNA manipulations and molecular techniques.** Total DNA from pure cultures of
92 *Sphingomonas* sp. LB126 was extracted using the Ultra Clean DNA Isolation Kit (MoBio,
93 Carlsbad, CA) following the manufacturer's recommendations or using standard methods (37)
94 when a higher DNA concentration was needed. Plasmid DNA extractions, restriction enzyme
95 digestions, ligations, transformations, sequencing and agarose gel electrophoresis were carried
96 out using standard methods (37).

97

98 **Polymerase chain reaction (PCR).** Degenerate primers for amplifying conserved sequences
99 of the gene encoding the angular dioxygenase were used as described elsewhere (15). PCR
100 products were purified and cloned into either the pGEM-T or pDrive plasmids. The RT-PCR

101 reactions were performed in 25 μ l with 5 ng of total RNA and 20 pmol of each primer with
102 OneStep RT-PCR Kit (Qiagen, Belgium). Total RNA extractions were performed using the
103 RNeasy kit (Qiagen, Valencia, CA) and further purified by spin column and DNase I
104 treatment according to the manufacturer's instructions. The thermocycler program used for
105 the RT-PCR reactions was as follows: 60°C for 30 min, 94°C for 15 min, 30 cycles (94°C for
106 30 s, 50°C for 30 s, 72°C for 45 s), and 72°C for 7 min.

107

108 **Southern Blot detection of catabolic genes.** Genomic DNA (2 μ g) was digested with either
109 BamHI, NotI, NsiI or a combination of these enzymes, separated by gel electrophoresis, then
110 blotted onto a positively charged nylon membrane (Amersham, Buckinghamshire, UK) using
111 standard protocols (37). For Southern Blot detection a PCR-amplified DIG-labeled probe was
112 prepared according to the manufacturer's recommendations (Roche Diagnostics, Mannheim,
113 Germany). Pre-hybridization and hybridization were carried out at 68°C. After hybridization,
114 the membrane was washed twice with 2 x SSC (20 x SSC: NaCl, 3 mol/l; Na-citrate, 0.3
115 mol/l; pH 7.0) containing 0.1% sodium dodecyl sulfate (SDS) (w/v) for 5 min at room
116 temperature and twice with 0.1 x SSC containing 0.1% SDS for 15 min at 68°C. Detection
117 was carried out following standard protocols (37). To isolate catabolic genes, total DNA (10
118 μ g) was digested with BamHI and NsiI separated by gel electrophoresis and DNA fragments
119 of about 7 kb recovered from the agarose gel. The obtained DNA was cloned into pGEM5Z
120 (Promega) and transformed into *E. coli* Top10. Resulting clones were screened by PCR using
121 the above-mentioned primers.

122

123 **Construction of plasmids for protein overexpression.** Construction of the plasmids used in
124 this study involved multiple PCR amplifications and cloning steps. The *flnA1A2* fragment
125 (1842 bp) was amplified by PCR with the primer pairs: 5'-
126 CATATGGCCACAGCCCTCATGAACCACCC-3' and 5'-

127 *AAGCTTGGCGCTCACAGGAACACCG-3'*, introducing NdeI and HindIII sites (*italics*) at
128 the ends of the amplicon. The PCR product was cloned into pDrive (Qiagen), sequenced, then
129 subcloned into the NdeI and HindIII sites of expression vector pET-30f (Novagen). This
130 construct was transformed into *E. coli* BL21(DE3) for expression analysis.

131

132 **Sodium dodecyl sulfate-polyacrylamide gel electrophoresis (SDS-PAGE).** Bacterial cells
133 were pelleted by centrifugation and washed with 10 ml ice-cold phosphate buffer (140 mM
134 NaCl, 10 mM Na₂HPO₄, 2.7 mM KCl, 1.8 mM NaH₂PO₄, pH 7.4). To the pellet was added 1
135 ml of ice-cold phosphate buffer and 550 µl of the suspension was subjected to sonication on
136 ice for 20 s (5 s pulse interval; 40% of maximum amplitude). After centrifugation the
137 supernatant and the pellet were mixed with an equal volume of loading solution. SDS-PAGE
138 was performed on mini gels containing 13.3 % polyacrylamide. After electrophoresis, protein
139 staining was performed with Coomassie brilliant blue R-250.

140

141 **Dioxygenase overexpression and in vivo assays.** Strain BL21(DE3)(pET30f*flnA1A2*) was
142 grown overnight in 3 ml LB medium with the suitable antibiotics. This culture was used to
143 inoculate 25 ml LB medium (0.1% by volume), which was incubated at 42°C until an OD₆₀₀
144 of 0.5. IPTG was added to a final concentration of 0.5 mM. The cells were further incubated
145 for 7 h at 25°C. For in vivo assays, cells were centrifuged, washed and resuspended to an
146 OD₆₀₀ of approximately 2 in M9 (37) medium containing 0.2% glucose. Cells (25 ml) were
147 incubated for 48 h at 25°C with 5 ml silicone oil containing 0.1 g/l of each tested PAH.

148

149 **GC-MS analysis of PAH oxidation products.** Water-soluble products resulting from PAH
150 oxidation were extracted from the aqueous phase of bacterial suspension by using, columns
151 filled with reverse phase-bonded silica (Upti-clean C18U, 0.5 g, Interchim, Montluçon,
152 France). Columns were washed with 10 ml water then eluted with 1 ml ethyl acetate. The

153 solvent was dried over sodium sulfate and evaporated under nitrogen gas. The dried extracts
154 were then dissolved in 100 or 200 μ l acetonitrile, before being derivatized with *N,O*-
155 *bis*(trimethylsilyl)trifluoroacetamide:trimethylchlorosilane (BSTFA) or *n*-butylboronate
156 (NBB). In order to quantify the dihydrodiols formed upon incubation of
157 BL21(DE3)(pET30fflnA1A2 recombinant cells with PAHs, 2,3-dihydrobiphenyl (Sigma-
158 Aldrich) was added to 0.1 μ M final concentration in the aqueous phase prior to solid phase
159 extraction, and was used as an internal standard. After derivatization and GC-MS analysis,
160 NBB dihydrodiol derivates were quantified on the basis of peak area using a calibration curve
161 generated by analyzing known amounts of anthracene 1,2-dihydrodiol. GC-MS analysis of
162 trimethylsilyl derivatives was carried out as previously described (18). NBB derivatives were
163 separated on MDN-12 capillary column (30 m, 0.25 mm internal diameter; Supelco) using
164 helium as carrier gas at 1 ml/min. The oven temperature was held at 75°C for 1 min, then
165 increased to 300°C at 14°/min, and held at 300° for 8 min. The mass spectrometer was
166 operated in the selected ion monitoring mode, selecting *m/z* values corresponding to the
167 expected masses (M^+) of the dihydrodiol derivatives (228 for naphthalene, 278 for anthracene
168 and phenanthrene). The NBB derivative of trihydroxybiphenyl, the oxidation product of
169 dibenzofuran, was monitored at a *m/z* value of 268. The fluorene derivative was detected at a
170 *m/z* of 196 (M^+ - OBC₄H₉), because in contrast to other dihydrodiol derivatives, the abundance
171 of the M^+ ion was very low.

172

173 **DNA and protein sequence analysis.** Sequence analysis was performed using the
174 DNASTAR software package (Lasergene Inc., Madison, WI). The BLAST search tool was
175 used for homology searches (1). Multiple alignments and phylogenetic trees were produced
176 using the DNASTAR and MEGA3.1 softwares (23).

177

178 **Nucleotide sequence accession number.** The nucleotide sequence described in this report
179 has been deposited in the Genbank database under accession number EU024110.
180

181
182
183
184
185
186
187
188
189
190
191
192
193
194
195
196
197
198
199
200
201
202
203
204
205
206

RESULTS AND DISCUSSION

Cloning and sequence analysis of genes encoding a novel angular dioxygenase.

Sphingomonas strain LB126 has been studied for its ability to grow on fluorene and degrade phenanthrene, anthracene and fluoranthene by cometabolism (47). In order to detect genes potentially involved in the initial attack of PAHs, a PCR strategy was chosen. The genes involved in fluorene oxidation in strain LB126 were expected to display some similarity with counterparts already described in other PAH degrading *Sphingomonas* strains. Many primer pairs corresponding to conserved domains of previously described PAH dioxygenases were tested (7, 19, 24, 28), but no amplification could be obtained (data not shown). Given the dearth of information regarding fluorene degradation genes in Gram-negative bacteria, primers specific to angular dioxygenase genes from Gram-positive bacteria were tested.

Using a set of such primers (15) and total DNA as a template, a 267 bp DNA fragment was amplified, which upon sequencing and translation, revealed 57 % protein sequence identity with a peptide internal to the dibenzofuran 4,4a-dioxygenase α subunit of *Terrabacter* sp. DBF63 (20). The 267 bp fragment was then used as a DIG labeled probe in Southern blot experiments on whole genome extracts of strain LB126. A 6.9 kb fragment encoding four entire open reading frames (ORF) (ORFs 3-6) and three truncated ones (ORFs 1,2 and 7) was recovered (Table 1). ORF1 did not share amino acid sequence similarities with any previously described fluorene catabolic genes, but showed significant homology to TonB-dependent receptor CirA from *Sphingomonas wittichii* strain RW1 (36%) and *Novosphingobium aromaticivorans* F199 (34%). ORF2 encoded a truncated transposase, suggesting that the adjacent gene cluster was probably acquired by horizontal transfer although no change in GC-content was noticed. ORFs 3-7 showed a genetic organization similar to that of the dibenzofuran catabolic operon from *Terrabacter* sp. DBF63 (20) (Fig. 2). Nevertheless, the product of ORF3, a putative dehydrogenase, did not share significant protein sequence similarity with its counterpart (FlnB) from strain DBF63. The highest degree of similarity was

207 found with putative dehydrogenases identified in whole genome sequencing projects of
208 *Mycobacterium* strains MCS and KMS. ORF4 and ORF5 encode the α and β subunits of a
209 putative angular dioxygenase. Their amino acid sequence showed moderate identity (63% and
210 51%) with DbfA1 and DbfA2 from strain DBF63. Phylogenetic analysis revealed that the
211 ORF4 product did not cluster with dioxygenase α subunits from other sphingomonads, and
212 was only distantly related to the angular dioxygenase from *Sphingomonas witichii* strain RW1
213 (4). The closest homologues within Sphingomonads were the dioxygenase α subunits from
214 the carbazole-degrading strains *Sphingomonas* sp. KA1 (36 % of protein identity) (41) and
215 *Sphingomonas* sp. CB3 (35 % of protein identity) (40). Interestingly, strain KA1 (41) harbors
216 genes whose products were predicted to catalyze protocatechuate degradation, similar to the
217 *lig* genes of *Sphingomonas paucimobilis* SYK-6 (25) and the *fld* genes of *Sphingomonas* sp.
218 LB126 (48). It appears the genes involved in the initial oxidation of fluorene are more closely
219 related to genes from Gram-positive bacteria and that the genes involved in the degradation of
220 protocatechuate are more conserved in *Sphingomonas* species. ORF5 shows moderate protein
221 identity (48%) to the β subunit DbfA2 from Gram-positive dibenzofuran-degrading
222 *Paenibacillus* sp. YK5 (16). DbfA1 and DbfA2 from strain YK5 are the two subunits of a
223 dioxygenase able to oxidize dibenzo-*p*-dioxin, dibenzothiophene, fluorene, and fluoren-9-one,
224 compounds that could however not be utilized as growth substrates by strain YK5 (16).
225 Transcriptional expression of ORF4 was studied by RT-PCR. Total RNA was extracted from
226 cultures of *Sphingomonas* sp. LB126 grown in the presence of glucose or fluorene. The
227 primers used previously to amplify a 267-bp internal fragment of ORF4 were employed to
228 detect the same portion of cDNA. Results indicated that ORF4 expression was manifold up-
229 regulated in the presence of fluorene (data not shown).. Based on this finding and the
230 observation that ORF4 and ORF5 are the subunits of an angular dioxygenase component that
231 preferentially use fluorene as substrate (see below), we suggest that the two ORFs are
232 involved in the initial attack on fluorene. They were called *flnA1* and *flnA2*. The proteins

233 encoded by *flnA1A2* from *Sphingomonas* sp. LB126 were quite unique, since no functional
234 counterpart had been described so far in Gram-negative bacteria. ORF6, located downstream
235 of *flnA1A2*, showed 42% identity with FlnE, a *meta*-cleavage product hydrolase from strain
236 DBF63 (14). The truncated ORF7 showed similarity to a counterpart from strain DBF63
237 (FlnD1), encoding an extradiol dioxygenase α subunit. Since *flnD1* from strain LB126 lacks a
238 3' region, no conclusive homology search could be carried out. Altogether, our findings
239 indicate that the catabolic gene cluster present in strain LB126 might have been inherited by
240 lateral transfer from other genera of PAH-degrading bacteria (Fig. 2) (33).

241

242 **Functional expression of FlnA1A2 in *E. coli*.**

243 In order to study the catalytic activity of FlnA1A2, the corresponding genes were introduced
244 into pET30f and expressed in *E. coli* BL21(DE3). Protein extracts from IPTG-induced cells
245 were separated by SDS-PAGE. The cells overproduced two polypeptides with M_r of 45,000
246 and 14,000, that did not match exactly the expected sizes of FlnA1 and FlnA2 as calculated
247 from the deduced polypeptide sequence (49.5 and 19.4 kDa). Differences between the
248 theoretical and apparent molecular masses upon SDS-PAGE gels were also observed for the
249 DbfA1 and DbfA2 dioxygenase components from strain DBF63 (20). Significantly, it was
250 found that the recombinant proteins were inactive and mostly insoluble (Fig. 3). When the
251 recombinant strain was grown at 42°C up to an OD_{600} of 0.5, then subjected to IPTG
252 induction at room temperature, a greater proportion of the FlnA1 and FlnA2 proteins was
253 recovered in the soluble fraction (Fig. 3). In order to assess the catalytic activity of FlnA1A2
254 in *E. coli*, biotransformation assays were carried out using induced cells incubated separately
255 with fluorene, carbazole, dibenzofuran, dibenzothiophene and dibenzo-*p*-dioxin, as well as
256 with representative PAHs. Water-soluble oxidation products released into the culture medium
257 were extracted and analyzed using GC-MS. The detection of PAH oxidation products
258 demonstrated that the recombinant enzyme was active in vivo (Table 2), suggesting that it

259 recruited unspecific electron carriers from the host for function. When strain
260 BL21(DE3)(pET30f), which lacked FlnA1A2, was incubated with the same PAHs under
261 identical conditions, no oxidation product could be detected, demonstrating that FlnA1A2 was
262 responsible for PAH transformation (Table 2).

263

264 **Substrate range of FlnA1A2.**

265 The substrate range of FlnA1A2 was investigated and compared with those of the well-
266 studied angular dioxygenases DFDO (dibenzofuran 4,4a-dioxygenase) from *Terrabacter* sp.
267 strain DBF63 (20) and CARDO (carbazole 1,9a-dioxygenase from *Pseudomonas*
268 *resinovorans* sp. CA10 (31, 38). When fluorene was used as substrate, three oxidation
269 products could be detected (Table 2). This could be due to the limited activity of FlnA1A2
270 since no specific ferredoxin nor ferredoxin reductase were expressed at the same time. The
271 major product was identified as 1-hydro-1,1a-dihydroxy-9-fluorenone (63 %) based on the
272 *m/z* fragment pattern of its mass spectrum, which was identical to that of the DFDO-mediated
273 oxidation product of fluorene (20, 27) and 9-fluorenone by CARDO (44). Moreover the
274 conversion ration of 9-fluorenone by CARDO was lower in comparison with dibenzofuran and
275 carbazole. Interestingly CARDO does not yield 1-hydro-1,1a-dihydroxy-9-fluorenone when
276 fluorene is used as substrate (44). The oxygenation for fluorene including monooxygenation
277 and lateral dioxygenation was hard to be catalyzed by CARDO suggesting that fluorene is not
278 a preferable substrate for CARDO (44). Fluorenone-dihydrodiol (7 %) and dihydroxyfluorene
279 (29 %) were also produced by FlnA1A2 from strain LB126. The latter product was not
280 formed by DFDO. Fluorenone-dihydrodiol probably resulted from spontaneous transformation
281 of 1-hydro-1,1a-dihydroxy-9-fluorenone since this product was not detected after short
282 incubations. Fluorenone is likely oxidized to fluorenone by a non specific dehydrogenase from
283 *E. coli*. Indeed, we also observed such a spontaneous oxidation upon incubation of fluorenone
284 with the control strain BL21(DE3)(pET30f) lacking the *flnA1A2* construct. Therefore, a

285 dehydrogenase is probably not essential to transform fluoreneol to fluorenone but may be
286 required *in vivo* to catalyze the reaction at a reasonable rate. 1-Hydro-1,1a-dihydroxy-9-
287 fluorenone also accumulated when fluoreneol or fluorenone were used as substrates, showing
288 that FlnA1A2 was involved in at least two steps in fluorene catabolism (Fig. 1). Since no
289 specific ferredoxin or ferredoxin reductase was expressed at the same time no fluoreneol or
290 fluorenone was detected. Given the low activity of FlnA1A2 and the necessity of
291 monooxygenation before angular dioxygenation can occur, fluoreneol and fluorenone are
292 probably instantly consumed and are therefore not present.

293 Three heteroatomic analogs of fluorene, i.e. dibenzofuran, carbazole and dibenzothiophene
294 were tested as substrates for angular oxidation. Dibenzofuran was transformed into 2,2',3-
295 trihydroxybiphenyl by FlnA1A2, as previously found for DFDO (20) and CARDO (31). The
296 initial attack occurred at the 4 and 4a carbon atoms as put forward by Fortnagel et al. in 1989
297 (8). The dioxygenation of dibenzofuran produces a highly unstable hemiacetal product that
298 could not be observed. Incubation with dibenzothiophene produced traces of
299 dibenzothiophene-sulfoxide and dibenzothiophene-sulfone. These metabolites were
300 previously identified as metabolic intermediates of dibenzothiophene degradation by
301 *Brevibacterium sp.* DO (46), DFDO (27) and CARDO (31). Since FlnA1A2 was able to
302 perform angular dioxygenation on fluorene and dibenzofuran, hydroxylation of
303 dibenzothiophene-sulfone at the angular position was expected. The activity of the enzyme
304 towards dibenzothiophene might have been too low to detect an angular dioxygenation
305 product by GC-MS. Even though carbazole is a structural analogue of fluorene, no angular
306 oxidation product could be identified. The crystal structure of CARDO bound with carbazole
307 was solved and a molecular mechanism of angular dioxygenation for carbazole was proposed
308 (2). Given the low protein identity between CARDO and FlnA1 (16%) no hypothesis could be
309 established why FlnA1A2 does not perform angular dioxygenation on carbazole. Mono- and
310 dihydroxycarbazole were the only oxidation products detected by GC-MS. DFDO from

311 *Terrabacter* sp. DBF63 was not able to perform angular dioxygenation on this substrate.
312 Detection of monohydroxycarbazole suggests that FlnA1A2 transforms carbazole to the
313 corresponding dihydrodiol by lateral dioxygenation. Resnick et al. reported that carbazole
314 dihydrodiols are unstable and spontaneously form monohydroxycarbazole by dehydration
315 (35). CARDO released 2'-aminobiphenyl-2,3-diol upon angular oxidation of carbazole (31).
316 Incubation with dibenzo-*p*-dioxin yielded 2,3,2'-trihydroxydiphenylether via angular
317 dioxygenation based on the *m/z* fragments described from DFDO and CARDO.

318 Since *Sphingomonas* sp. LB126 is able to use phenanthrene, fluoranthene and anthracene in
319 cometabolic degradation (47), we tested whether FlnA1A2 would attack these PAHs. *cis*-
320 9,10-Dihydroxy-9,10-dihydrophenanthrene, previously identified as a product formed by
321 pyrene dioxygenase from *Mycobacterium* 6PY1 (22), was detected as the major oxidation
322 product of phenanthrene. Interestingly, *cis*-3,4-dihydroxy-3,4-dihydrophenanthrene which is
323 produced in the catabolic pathway of known phenanthrene degraders including
324 sphingomonads (7, 34, 50) was not formed. Monohydroxyphenanthrene was detected in low
325 amounts (4 %) and might have resulted from spontaneous dehydration of the corresponding
326 dihydrodiol. In contrast, DFDO did not produce any metabolite when incubated in the
327 presence of phenanthrene (21). When incubated with fluoranthene, trace amounts of
328 monohydroxyfluoranthene could be detected. Anthracene yielded three metabolites. The
329 major compound could be identified as *cis*-1,2-dihydroxy-1,2-dihydroanthracene by
330 comparison to the oxidation product formed by Phn1 from *Sphingomonas* sp. CHY-1 (7).
331 Trace amounts of monohydroxyanthracene were also present. CARDO produced the same
332 metabolites but DFDO did not. Moreover, a second putative anthracene-diol could be
333 identified. Its mass spectrum was similar to that of *cis*-1,2-dihydroxy-1,2-dihydroanthracene
334 but the retention time was different. Since no angular attack on anthracene is possible without
335 a preliminary monooxygenation, we suggest that this compound could be *cis*-2,3-dihydroxy-
336 2,3-dihydroanthracene. This metabolite has not been produced by any other enzyme reported

337 so far. When incubated with biphenyl or naphthalene, FlnA1A2 produced the well known
338 metabolites also reported for DFDO and CARDO (20, 31). Our results show that FlnA1A2
339 from strain LB126 is unique in that it shares characteristics with both DFDO and CARDO.
340 The catalytic activity of FlnA1A2 towards fluorene and other PAHs was compared by
341 estimating the amount of di- or trihydroxylated products formed by strain
342 BL21(DE3)(pET30f*FlnA1A2* after overnight incubation. Products were extracted and
343 quantified as NBB derivatives by GC-MS analysis as described in Materials and Methods.
344 Results showed that 1-hydro-1,1a-dihydroxy-9-fluorenone (97.5 μM) and 9,10-phenanthrene
345 dihydrodiol (96.3 μM) accumulated at highest concentrations indicating that fluorene and
346 phenanthrene were preferred substrates (Table 3). GC-MS data on NBB derivatives confirmed
347 that FlnA1A2 attacked fluorene in angular position and generated 9,10-phenanthrene
348 dihydrodiol instead of the more common 3,4-isomer. In this respect, the activity of FlnA1A2
349 is quite different from that of other known phenanthrene dioxygenases. In addition, FlnA1A2
350 showed a relatively low activity with naphthalene. Dibenzofuran and dibenzo-*p*-dioxin
351 apparently yielded low amounts of products, essentially because the trihydroxylated
352 compounds generated from these substrates reacted poorly with NBB (data not shown). The
353 amount of the trihydroxylated products was therefore tentatively determined based on the
354 peak area of the trimethylsilyl derivatives using 2,3-dihydroxybiphenyl as standard (Table 3).
355 These results, together with the fact that neither phenanthrene nor dibenzofuran can support
356 growth of strain LB126, provide additional evidence that FlnA1A2 acts as an angular
357 dioxygenase specifically dedicated to fluorene initial attack.

358 The initial step in the aerobic bacterial degradation of PAHs is the introduction of two
359 hydroxyl groups into the benzene ring, forming *cis*-dihydrodiols. Dioxygenases usually
360 perform oxygenation at lateral positions. This has been described in detail for naphthalene and
361 phenanthrene (6). Some information is available regarding initial dioxygenases from
362 sphingomonads, such as those encoded by the *bphA1A2f* genes from *Novosphingobium*

363 *aromaticivorans* sp. F199 (36), *Sphingobium yanoikuyae* B1 (29), and the *phnA1aA2a* genes
364 from *Sphingomonas* sp. CHY-1 (18). These strains are able to oxidize fluorene but cannot use
365 it as sole source of carbon and energy. The enzymes involved in fluorene oxidation in strain
366 LB126 show relatively high degrees of sequence identity with proteins from Gram-positive
367 bacteria, and were likely acquired by lateral gene transfer since a truncated transposase was
368 identified upstream of the catabolic genes. In angular dioxygenation the carbon atom bonded
369 to the carbonyl group in 9-fluoreneol and the adjacent carbon atom in the aromatic ring are
370 both oxidized. FlnA1A2 was able to perform monooxygenations in which the methylene
371 carbon atom in fluorene or the sulfur atom in dibenzothiophene were oxidized. This is an
372 essential step to increase the electron withdrawing capabilities necessary for angular
373 dioxygenation to occur. In dibenzofuran, dibenzo-*p*-dioxin and carbazole, the connecting
374 atoms, O and N respectively, have high electronegativities and these compounds must not be
375 oxidized before angular dioxygenation (30). FlnA1A2 was most active in the presence of
376 fluorene and dibenzofuran. The limited activity towards other PAHs could explain the
377 necessity for a second carbon source to support growth. FlnA1A2 from *Sphingomonas* sp.
378 LB126 was able to perform monooxygenations, angular and lateral oxygenations on PAHs
379 and heteroaromatics that were not oxidized by DFDO from *Terrabacter* sp. DBF63.
380

381

ACKNOWLEDGEMENTS

382 L.S. gratefully acknowledges the Fund for the Promotion of Research in Industry and
383 Agriculture (F.R.I.A.), Belgium, for providing a doctoral fellowship. L.S. also wishes to thank
384 the members of the Unit of Physiological Biochemistry (FYSA), Catholic University of
385 Louvain, for their daily help and constructive remarks for many years.

386

- 388 1. **Altschul, S. F., T. L. Madden, A. A. Schaffer, J. Zhang, Z. Zhang, W. Miller, and**
389 **D. J. Lipman.** 1997. Gapped BLAST and PSI-BLAST: a new generation of protein
390 database search programs. *Nucleic Acids Res* **25**:3389-402.
- 391 2. **Ashikawa, Y., Z. Fujimoto, H. Noguchi, H. Habe, T. Omori, H. Yamane, and H.**
392 **Nojiri.** 2006. Electron transfer complex formation between oxygenase and ferredoxin
393 components in Rieske nonheme iron oxygenase system. *Structure* **14**:1779-89.
- 394 3. **Bastiaens, L., D. Springael, P. Wattiau, H. Harms, R. deWachter, H. Verachtert,**
395 **and L. Diels.** 2000. Isolation of adherent polycyclic aromatic hydrocarbon (PAH)-
396 degrading bacteria using PAH-sorbing carriers. *Appl Environ Microbiol* **66**:1834-43.
- 397 4. **Bunz, P. V., and A. M. Cook.** 1993. Dibenzofuran 4,4a-dioxygenase from
398 *Sphingomonas* sp. strain RW1: angular dioxygenation by a three-component enzyme
399 system. *J Bacteriol* **175**:6467-75.
- 400 5. **Casellas, M., M. Grifoll, J. M. Bayona, and A. M. Solanas.** 1997. New metabolites
401 in the degradation of fluorene by *Arthrobacter* sp. strain F101. *Appl Environ*
402 *Microbiol* **63**:819-26.
- 403 6. **Cerniglia, C. E.** 1992. Biodegradation of polycyclic aromatic hydrocarbons.
404 *Biodegradation* **3**:351-368.
- 405 7. **Demanèche, S., C. Meyer, J. Micoud, M. Louwagie, J. C. Willison, and Y.**
406 **Jouanneau.** 2004. Identification and functional analysis of two aromatic-ring-
407 hydroxylating dioxygenases from a *Sphingomonas* strain that degrades various
408 polycyclic aromatic hydrocarbons. *Appl Environ Microbiol* **70**:6714-25.
- 409 8. **Fortnagel, P., H. Harms, R. M. Wittich, W. Francke, S. Krohn, and H. Meyer.**
410 1989. Cleavage of dibenzofuran and dibenzodioxin ring systems by a *Pseudomonas*
411 bacterium. *Naturwissenschaften* **76**:222-3.

- 412 9. **Grifoll, M., M. Casellas, J. M. Bayona, and A. M. Solanas.** 1992. Isolation and
413 characterization of a fluorene-degrading bacterium: identification of ring oxidation
414 and ring fission products. *Appl Environ Microbiol* **58**:2910-7.
- 415 10. **Grifoll, M., S. Selifonov, and P. Chapman.** 1995. Transformation of substituted
416 fluorenes and fluorene analogs by *Pseudomonas* sp. strain F274. *Appl Environ*
417 *Microbiol* **61**:3490-3493.
- 418 11. **Grifoll, M., S. A. Selifonov, and P. J. Chapman.** 1994. Evidence for a novel
419 pathway in the degradation of fluorene by *Pseudomonas* sp. strain F274. *Appl Environ*
420 *Microbiol* **60**:2438-49.
- 421 12. **Grifoll, M., S. A. Selifonov, C. V. Gatlin, and P. J. Chapman.** 1995. Actions of a
422 versatile fluorene-degrading bacterial isolate on polycyclic aromatic compounds.
423 *Appl. Environ. Microbiol.* **61**:3711–3723.
- 424 13. **Habe, H., J.-S. Chung, A. Ishida, K. Kasuga, K. Ide, T. Takemura, H. Nojiri, H.**
425 **Yamane, and T. Omori.** 2005. The fluorene catabolic linear plasmid in *Terrabacter*
426 sp. strain DBF63 carries the beta-ketoadipate pathway genes, *pcaRHGBDCFIJ*, also
427 found in proteobacteria. *Microbiology* **151**:3713-3722.
- 428 14. **Habe, H., J. S. Chung, H. Kato, Y. Ayabe, K. Kasuga, T. Yoshida, H. Nojiri, H.**
429 **Yamane, and T. Omori.** 2004. Characterization of the upper pathway genes for
430 fluorene metabolism in *Terrabacter* sp. strain DBF63. *J Bacteriol* **186**:5938-44.
- 431 15. **Iida, T., Y. Mukouzaka, K. Nakamura, and T. Kudo.** 2002. Plasmid-borne genes
432 code for an angular dioxygenase involved in dibenzofuran degradation by *Terrabacter*
433 sp. strain YK3. *Appl Environ Microbiol* **68**:3716-23.
- 434 16. **Iida, T., K. Nakamura, A. Izumi, Y. Mukouzaka, and T. Kudo.** 2006. Isolation and
435 characterization of a gene cluster for dibenzofuran degradation in a new dibenzofuran-
436 utilizing bacterium *Paenibacillus* sp. strain YK5. *Arch Microbiol* **184**:305-15.

- 437 17. **Johnsen, A. R., L. Y. Wick, and H. Harms.** 2005. Principles of microbial PAH-
438 degradation in soil. *Environ Pollut* **133**:71-84.
- 439 18. **Jouanneau, Y., C. Meyer, J. Jakoncic, V. Stojanoff, and J. Gaillard.** 2006.
440 Characterization of a naphthalene dioxygenase endowed with an exceptionally broad
441 substrate specificity toward polycyclic aromatic hydrocarbons. *Biochemistry*
442 **45**:12380-91.
- 443 19. **Kahng, H. Y., K. Nam, J. J. Kukor, B. J. Yoon, D. H. Lee, D. C. Oh, S. K. Kam,**
444 **and K. H. Oh.** 2002. PAH utilization by *Pseudomonas rhodesiae* KK1 isolated from a
445 former manufactured-gas plant site. *Appl Microbiol Biotechnol* **60**:475-80.
- 446 20. **Kasuga, K., H. Habe, J. S. Chung, T. Yoshida, H. Nojiri, H. Yamane, and T.**
447 **Omori.** 2001. Isolation and characterization of the genes encoding a novel oxygenase
448 component of angular dioxygenase from the gram-positive dibenzofuran-degrader
449 *Terrabacter* sp. strain DBF63. *Biochem Biophys Res Commun* **283**:195-204.
- 450 21. **Kasuga, K., H. Nojiri, H. Yamane, and T. Omori.** 1997. Genes of enzymes
451 involved in the biodegradation of carbazole, dibenzofuran, fluorene, and dibenzo-*p*-
452 dioxin by bacteria. *Water Sci Technol* **36**:9-16.
- 453 22. **Krivobok, S., S. Kuony, C. Meyer, M. Louwagie, J. C. Willison, and Y.**
454 **Jouanneau.** 2003. Identification of pyrene-induced proteins in *Mycobacterium* sp.
455 strain 6PY1: evidence for two ring-hydroxylating dioxygenases. *J Bacteriol* **185**:3828-
456 41.
- 457 23. **Kumar, S., K. Tamura, and M. Nei.** 2004. MEGA3: Integrated software for
458 Molecular Evolutionary Genetics Analysis and sequence alignment. *Brief Bioinform*
459 **5**:150-63.
- 460 24. **Larkin, M. J., C. C. Allen, L. A. Kulakov, and D. A. Lipscomb.** 1999. Purification
461 and characterization of a novel naphthalene dioxygenase from *Rhodococcus* sp. strain
462 NCIMB12038. *J Bacteriol* **181**:6200-4.

- 463 25. **Masai, E., S. Shinohara, H. Hara, S. Nishikawa, Y. Katayama, and M. Fukuda.**
464 1999. Genetic and biochemical characterization of a 2-pyrone-4, 6-dicarboxylic acid
465 hydrolase involved in the protocatechuate 4, 5-cleavage pathway of *Sphingomonas*
466 *paucimobilis* SYK-6. J Bacteriol **181**:55-62.
- 467 26. **Mergeay, M., D. Nies, H. G. Schlegel, J. Gerits, P. Charles, and F. Van Gijsegem.**
468 1985. *Alcaligenes eutrophus* CH34 is a facultative chemolithotroph with plasmid-
469 bound resistance to heavy metals. J Bacteriol **162**:328-334.
- 470 27. **Monna, L., T. Omori, and T. Kodama.** 1993. Microbial degradation of
471 dibenzofuran, fluorene, and dibenzo-*p*-dioxin by *Staphylococcus auriculans* DBF63.
472 Appl Environ Microbiol **59**:285-9.
- 473 28. **Moser, R., and U. Stahl.** 2001. Insights into the genetic diversity of initial
474 dioxygenases from PAH-degrading bacteria. Appl Microbiol Biotechnol **55**:609-18.
- 475 29. **Ni Chadhain, S. M., E. M. Moritz, E. Kim, and G. J. Zylstra.** 2007. Identification,
476 cloning, and characterization of a multicomponent biphenyl dioxygenase from
477 *Sphingobium yanoikuyae* strain B1. J. Ind. Microbiol. Biotechnol. **34**:605-13.
- 478 30. **Nojiri, H., H. Habe, and T. Omori.** 2001. Bacterial degradation of aromatic
479 compounds via angular dioxygenation. J Gen Appl Microbiol **47**:279-305.
- 480 31. **Nojiri, H., J. Nam, M. Kosaka, K. Morii, T. Takemura, K. Furihata, H. Yamane,**
481 **and T. Omori.** 1999. Diverse oxygenations catalyzed by carbazole 1,9a-dioxygenase
482 from *Pseudomonas* sp. CA10. J Bacteriol **181**:3105-3113.
- 483 32. **Pinyakong, O., H. Habe, A. Kouzuma, H. Nojiri, H. Yamane, and T. Omori.**
484 2004. Isolation and characterization of genes encoding polycyclic aromatic
485 hydrocarbon dioxygenase from acenaphthene and acenaphthylene degrading
486 *Sphingomonas* sp. strain A4. FEMS Microbiol Lett **238**:297-305.

- 487 33. **Pinyakong, O., H. Habe, and T. Omori.** 2003. The unique aromatic catabolic genes
488 in sphingomonads degrading polycyclic aromatic hydrocarbons (PAHs). *J Gen Appl*
489 *Microbiol* **49**:1-19.
- 490 34. **Pinyakong, O., H. Habe, N. Supaka, P. Pinpanichkarn, K. Juntongjin, T.**
491 **Yoshida, K. Furihata, H. Nojiri, H. Yamane, and T. Omori.** 2000. Identification of
492 novel metabolites in the degradation of phenanthrene by *Sphingomonas* sp. strain P2.
493 *FEMS Microbiol Lett* **191**:115-21.
- 494 35. **Resnick, S. M., D. S. Torok, and D. T. Gibson.** 1993. Oxidation of carbazole to 3-
495 hydroxycarbazole by naphthalene 1,2-dioxygenase and biphenyl 2,3-dioxygenase.
496 *FEMS Microbiol Lett* **113**:297-302.
- 497 36. **Romine, M. F., L. C. Stillwell, K. K. Wong, S. J. Thurston, E. C. Sisk, C. Sensen,**
498 **T. Gaasterland, J. K. Fredrickson, and J. D. Saffer.** 1999. Complete sequence of a
499 184-kilobase catabolic plasmid from *Sphingomonas aromaticivorans* F199. *J Bacteriol*
500 **181**:1585-602.
- 501 37. **Sambrook, J., E. F. Fritsch, and T. Maniatis.** 1990. *Molecular cloning: a laboratory*
502 *manual*. Cold Spring Laboratory Harbor Press, U.S.A.
- 503 38. **Sato, S. I., J. W. Nam, K. Kasuga, H. Nojiri, H. Yamane, and T. Omori.** 1997.
504 Identification and characterization of genes encoding carbazole 1,9a-dioxygenase in
505 *Pseudomonas* sp. strain CA10. *J Bacteriol* **179**:4850-8.
- 506 39. **Selifonov, S. A., M. Grifoll, J. E. Gurst, and P. J. Chapman.** 1993. Isolation and
507 characterization of (+)-1,1a-dihydroxy-1-hydrofluoren-9-one formed by angular
508 dioxygenation in the bacterial catabolism of fluorene. *Biochem Biophys Res Commun*
509 **193**:67-76.
- 510 40. **Shepherd, J. M., and G. Lloyd-Jones.** 1998. Novel carbazole degradation genes of
511 *Sphingomonas* CB3: sequence analysis, transcription, and molecular ecology.
512 *Biochem Biophys Res Commun* **247**:129-35.

- 513 41. **Shintani, M., M. Urata, K. Inoue, K. Eto, H. Habe, T. Omori, H. Yamane, and H.**
514 **Nojiri.** 2007. The *Sphingomonas* plasmid pCAR3 is involved in complete
515 mineralization of carbazole. *J Bacteriol* **189**:2007-20.
- 516 42. **Story, S. P., E. L. Kline, T. A. Hughes, M. B. Riley, and S. S. Hayasaka.** 2004.
517 Degradation of aromatic hydrocarbons by *Sphingomonas paucimobilis* strain EPA505.
518 *Arch Environ Contam Toxicol* **47**:168-76.
- 519 43. **Story, S. P., S. H. Parker, S. S. Hayasaka, M. B. Riley, and E. L. Kline.** 2001.
520 Convergent and divergent points in catabolic pathways involved in utilization of
521 fluoranthene, naphthalene, anthracene, and phenanthrene by *Sphingomonas*
522 *paucimobilis* var. EPA505. *J Ind Microbiol Biotechnol* **26**:369-82.
- 523 44. **Takagi, T., H. Nojiri, T. Yoshida, H. Habe, and T. Omori.** 2002. Detailed
524 comparison between the substrate specificities of two angular dioxygenases,
525 dibenzofuran 4,4a-dioxygenase from *Terrabacter* sp. and carbazole 1,9a-dioxygenase
526 from *Pseudomonas resinovorans*. *Biotechnol Lett* **24**:2099-16.
- 527 45. **Trenz, S. P., K. H. Engesser, P. Fischer, and H. J. Knackmuss.** 1994. Degradation
528 of fluorene by *Brevibacterium* sp. strain DPO 1361: a novel C-C bond cleavage
529 mechanism via 1,10-dihydro-1,10-dihydroxyfluoren-9-one. *J Bacteriol* **176**:789-95.
- 530 46. **van Afferden, M., S. Schacht, J. Klein, and H. G. Trüper.** 1990. Degradation of
531 dibenzothiophene by *Brevibacterium* sp. DO. *Arch Microbiol* **153**:324-328.
- 532 47. **van Herwijnen, R., P. Wattiau, L. Bastiaens, L. Daal, L. Jonker, D. Springael, H.**
533 **A. Govers, and J. R. Parsons.** 2003. Elucidation of the metabolic pathway of
534 fluorene and cometabolic pathways of phenanthrene, fluoranthene, anthracene and
535 dibenzothiophene by *Sphingomonas* sp. LB126. *Res Microbiol* **154**:199-206.
- 536 48. **Wattiau, P., L. Bastiaens, R. van Herwijnen, L. Daal, J. R. Parsons, M. E.**
537 **Renard, D. Springael, and G. R. Cornelis.** 2001. Fluorene degradation by

- 538 *Sphingomonas* sp. LB126 proceeds through protocatechuic acid: a genetic analysis.
539 Res Microbiol **152**:861-72.
- 540 49. **Willison, J. C.** 2004. Isolation and characterization of a novel sphingomonad capable
541 of growth with chrysene as sole carbon and energy source. FEMS Microbiol Lett
542 **241**:143-50.
- 543 50. **Zylstra, G. J., and E. Kim** 1997. Aromatic hydrocarbon degradation by
544 *Sphingomonas yanoikuyae* B1. J. Ind. Microbiol. Biotechnol. **19**:408-414.
545
546

547 **Figure Legends**

548 **Figure 1.** Proposed pathways for fluorene degradation and bacteria involved. 1, *Arthrobacter*
549 sp. strain F101 (5, 9); 2, *Terrabacter* sp. strain DBF63 (27); 3, *Brevibacterium* sp. strain
550 DPO1361 (45); 4, *Pseudomonas* sp. strain F274 (11); 5, *Burkholderia cepacia* F297 (12); 6,
551 *Sphingomonas* sp. strain LB126 (48).

552

553 **Figure 2.** Genetic organization of the 6.9 kb DNA region containing fluorene catabolic genes
554 in *Sphingomonas* sp. LB126 compared to *Paenibacillus* sp. YK5 (AB201843), *Terrabacter*
555 sp. YK3 (AB075242), *Rhodococcus* sp. YK2 (AB070456) and *Sphingomonas* sp. KA1
556 (NC_008308) and *Terrabacter* sp. DBF63 (AP008980). The arrows indicate location and
557 direction of transcription of the ORFs. Black arrows represent genes involved in the initial
558 attack on fluorene; dark gray arrows indicate genes involved in the electron transport chain or
559 phthalate degradation (*pht*), white arrows indicate regulatory genes and light gray arrows
560 represent genes not directly involved in fluorene oxidation. ‘ Truncated ORF

561

562 **Figure 3.** Detection of FlnA1 and FlnA2 overproduced in *E. coli* BL21(DE3). Soluble
563 (supernatant) and insoluble proteins (pellet) were analysed on SDS-PAGE. *E. coli* harbouring
564 pET30f lacking the *flnA1A2* insert (V) was used as control. Protein extracts from cells,
565 overexpressing FlnA1A2 (V+I), grown at 37°C and 42°C up to an OD₆₀₀ of 0.5 prior to IPTG
566 induction are shown. Arrows indicate the α and β subunits of the angular dioxygenase.
567 Molecular mass (kDa): New England Biolabs, Prestained Protein Marker, Broad Range.

568

569

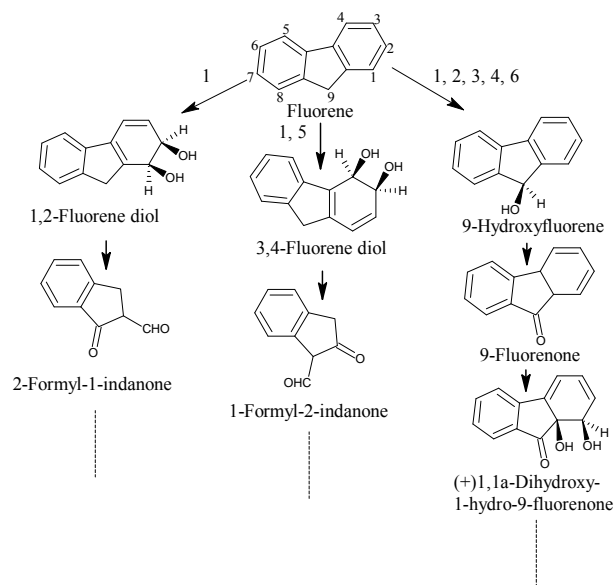

570

571 Fig. 1

572

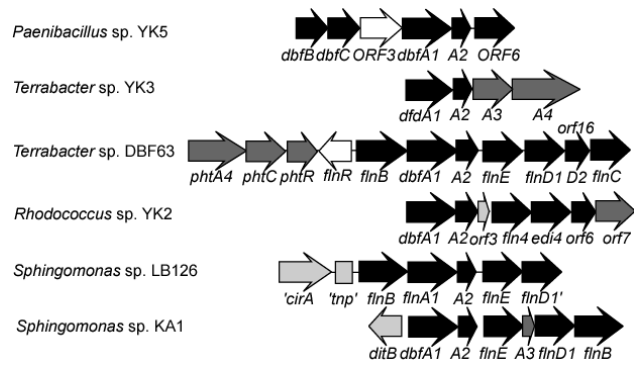

573

574 Fig. 2

575

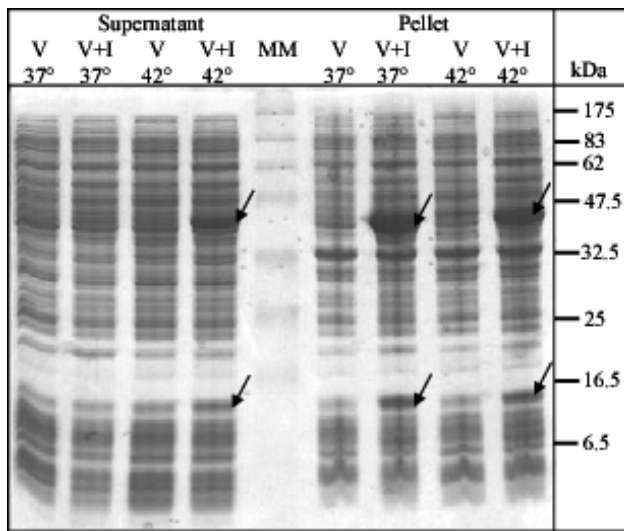

576

577 Fig. 3

578 Table 1. Homology search analyses of the recovered ORFs from fluorene-degrading *Sphingomonas* sp. strain LB126.

ORF	Gene	Probable function or product	Homologous protein	Source	Identity (%)	Accession number
ORF1	'cirA	TonB-dependent receptor	CirA	<i>Sphingomonas wittichii</i> RW1	36	YP_001262040
			CirA	<i>Novosphingobium aromaticivorans</i> DSM 12444	34	YP_001165948
ORF2	'mp'	Transposase	Transposase	<i>Mesorhizobium loti</i> MAFF303099	60	NP_085624
			Transposase	<i>Sinorhizobium medicae</i> WSM419	57	EAU08642
ORF3	flnB	Probable dehydrogenase	probable dehydrogenase	<i>Mycobacterium</i> sp. MCS	40	ABG07792
			probable dehydrogenase	<i>Mycobacterium</i> sp. KMS	40	ZP_01286209
			probable dehydrogenase	<i>Rhodobacterales</i> sp. HTCC2654	28	ZP_01014534
ORF4	flnA1	angular dioxygenase α subunit	DbfA1	<i>Terrabacter</i> sp. DBF63	63	BAC75993
			DbfA1_YK2	<i>Rhodococcus</i> sp. YK2	54	BAC00802
			DbfA1	<i>Paenibacillus</i> sp. YK5	52	BAE53401
ORF5	flnA2	angular dioxygenase β subunit	DbfA2	<i>Rhodococcus</i> sp. YK2	52	BAC00803
			DbfA1YK2	<i>Terrabacter</i> sp. DBF63	51	BAC75994
			DbfA2	<i>Paenibacillus</i> sp. YK5	48	BAE53402
ORF6	flnE	hydrolase	FlnE	<i>Terrabacter</i> sp. DBF63	42	BAE45094
			ORF4	<i>Rhodococcus</i> sp. YK2	42	BAC00805
			A/b hydrolase_1	<i>Mycobacterium</i> sp. MCS	30	YP_642596
ORF7	flnD1'	extradiol dioxygenase α subunit	FlnD1	<i>Terrabacter</i> sp. DBF63	12	BAC75996
			BphC6	<i>Rhodococcus rhodochrous</i>	12	BAD10908
			Edi4	<i>Rhodococcus</i> sp. YK2	12	BAC00806

579 Table 2. PAH selectivity of FlnA1A2 from *Sphingomonas* sp. LB126 as expressed in *E. coli* and comparison to DFDO (20) and CARDO (31).

Substrate	Possible products	Principal fragment ions ^a	Retention Time (min)	Yield (%) ^b	DFDO ^c	CARDO ^c
Naphthalene	<i>cis</i> -1,2-Dihydroxy-1,2-dihydronaphthalene ^d	306 (8), 275 (5), 203 (32), 191 (100)	13.455	92.9	+	+
	1-naphthol ^{d,g}	216 (86), 201 (100), 185 (46), 141 (24)	12.375	7.1	+	+
Biphenyl	<i>cis</i> -2,3-Dihydroxy-2,3-dihydrobiphenyl ^d	332 (52), 243 (22), 227 (100), 211(18)	15.134	83.9	+	+
	2-Hydroxybiphenyl ^{d,g}	242 (48), 227 (76), 211 (100), 165 (7), 152 (20)	12.910	8.5	+	+
	3-Hydroxybiphenyl ^{d,g}	242 (74), 227 (100), 211 (47), 165 (8), 152 (22)	14.214	7.6	+	+
Phenanthrene	<i>cis</i> -9,10-Dihydroxy-9,10-dihydrophenanthrene ^e	356 (16), 253, 191, 147 (100), 73 (99)	16.728	95.1	-	+
	Monohydroxyphenanthrene ^g	266 (100), 251 (65), 235 (27), 176 (13)	17.464	4.1	-	+
Anthracene	<i>cis</i> -1,2-Dihydroxy-1,2-dihydroanthracene ^{d,f}	356 (5), 266 (13), 253 (34), 191 (62), 147 (26), 73 (100)	17.348	68.5	-	+
	Anthracenedihydrodiol	356 (34), 266 (82), 253 (3), 191 (3), 147 (60), 73 (100)	17.874	26.8	-	-
	Monohydroxyanthracene ^g	266 (79), 251 (14), 235 (6), 191 (6), 165 (12), 73 (100)	17.260	4.7	-	+
Fluorene	Dihydroxyfluorene	342 (14), 253 (46), 152 (17), 73 (100)	18.477	28.9	-	+
	1-Hydro-1,1a dihydroxy-9-fluorenone ^d	358 (65), 253 (59), 147 (36), 73 (100)	16.788	63.6	+	-
	Fluorenol-dihydrodiol	360 (39), 270 (95), 242 (100), 181 (55), 165 (13)	16.455	7.4	-	-
9-Fluorenol	1-Hydro-1,1a-dihydroxy-9-fluorenone ^d	358 (40), 253 (41), 147 (39), 73 (100)	16.800	82	+	+
	Fluorenol-dihydrodiol	360 (34), 270 (90), 242 (100), 181 (78), 165 (23)	16.459	18	-	-
9-Fluorenone	1-Hydro-1,1a-dihydroxy-9-fluorenone ^d	358 (56), 253 (51), 147 (43), 73 (100)	16.795	76	+	+
	Fluorenol-dihydrodiol	360 (30), 270 (91), 242 (100), 181 (85), 165 (24)	16.459	24	-	-
Fluoranthene	Monohydroxyfluoranthene ^g	290 (81), 275 (54), 259 (47), 215 (76)	20.038	100	Not tested	+
Carbazole	Monohydroxycarbazole ^g	255 (100), 239 (51), 224 (47), 209 (22), 166 (11)	17.128	56.4	-	-
	Dihydroxycarbazole	343 (100), 327 (34), 252 (7), 164 (2)	18.688	9.7	-	-
	Monohydroxycarbazole ^g	327 (100), 312 (24), 165 (1), 73 (39)	18.997	33.9	-	-
Dibenzofuran	2,2',3-Trihydroxybiphenyl ^d	418 (50), 403 (5), 315 (70), 73 (100)	16.357	100	+	+
Dibenzo- <i>p</i> -dioxin	2,3,2'-Trihydroxydiphenyl ether ^d	434 (63), 419(11), 331 (77), 73 (100)	16.988	100	+	+

Dibenzothiophene	Dibenzothiophene-sulfone ^d	200 (7), 184 (100), 171 (7), 139 (18), 73 (4)	17.718	Traces	+	+
	Dibenzothiophene-sulfoxide ^d	216 (5), 200 (5), 184 (100), 147 (72), 73 (9)	17.735	Traces	+	+

580 ^a Products were identified by GC-MS analysis (TMS derivatisation). Fragment ions are expressed as *m/z* values.

581 ^b When multiple oxidation products were detected their relative abundance is indicated in %.

582 ^c The ability and inability to transform each compound are shown by “+” and “-”.

583 ^d Same mass spectrum as that of relevant PAH oxidation products generated by CARDO and DFDO, and previously identified based on ¹H and ¹³C
584 NMR analyses (31).

585 ^e Same retention time and mass spectrum as *cis*-9,10-dihydroxy-9,10-dihydrophenanthrene produced by Pdo1 (22).

586 ^f Same retention time and mass spectrum as *cis*-1,2-dihydroxy-12-dihydroanthracene produced by Phn1 (7).

587 ^g Monohydroxylated products are most probably formed by spontaneous dehydration of the corresponding diols.

588

589 Table 3: Comparison of the FlnA1A2 dioxygenase activity towards fluorene and other
 590 polycyclic substrates

Substrate	Properties of the products formed ^a		
	retention time (min)	m/z	concentration (μ M) ^b
Fluorene	15.55	280	97.5
Phenanthrene	15.92	278	96.3
Anthracene	14.66	278	9.1
	16.60	278	27.3
Naphthalene	12.11	228	1.92
Dibenzofuran	13.52	418	10.1
Dibenzo- <i>p</i> -dioxin	14.12	434	10.0

591 ^a Characteristics of the NBB derivatives, except for dibenzofuran and dibenzo-*p*-dioxin which
 592 were analyzed as the trimethyl silyl derivatives. Anthracene yielded two isomers, one of which
 593 was identified as anthracene 1,2-dihydrodiol (retention time: 16.60 min).

594 ^b Concentrations calculated in the bacterial suspension after 23 h of incubation at 25°C.

595 Values are means of duplicates experiments. The standard error was less than 10%.