

Born-Infeld Action in String Theory

Konstantin George Savvidy

A DISSERTATION
PRESENTED TO THE FACULTY
OF PRINCETON UNIVERSITY
IN CANDIDACY FOR THE DEGREE
OF DOCTOR OF PHILOSOPHY

RECOMMENDED FOR ACCEPTANCE
BY THE DEPARTMENT OF PHYSICS

JUNE 1999

arXiv:hep-th/9906075v2 5 Jul 1999

©Copyright by Konstantin G Savvidy, 1999. All rights reserved.

Abstract

In this thesis I present applications of the Born-Infeld action to the description of D-branes, mostly in the context of type IIB string theory. I briefly review the relevant aspects of the general formalism, including the efforts toward generalization of this action to the non-Abelian case. In the second Chapter I present the construction of a fundamental string attached to a threebrane, whereby the string is made out of the wrapped brane. This interpretation withstands a rather detailed scrutiny, including the magnitude of the static tension and of the B-I charge; and Polchinski's mixed Dirichlet/Neumann boundary conditions for small perturbations of the string. The latter arise dynamically from the full non-linear equations of motion. Also, the Born-Infeld charge is shown to produce the correct form of dipole radiation under the influence of harmonic oscillations of the string.

The third Chapter arises out of two papers on the application of these ideas to the AdS/CFT correspondence. Using the essentially non-perturbative nature of the B-I action we were able to construct in the near-horizon geometry of N D3-branes the color-singlet baryon vertex of the $SU(N)$ gauge theory as a fivebrane wrapped on the S^5 sphere, with B-I strings playing the role of the quarks. Also, in the asymptotically flat background we obtain a smooth classical description of the Hanany-Witten phenomenon, whereby one drags a flat fivebrane across the stack of threebranes, and B-I strings stretching between the two appear and disappear without any discontinuity.

In the case of non-extremal background we construct baryons of the three-dimensional non-supersymmetric theory, the low energy dynamics of which was conjectured to be equivalent to ordinary QCD. Our approach allows to exhibit confining properties of color flux tubes, i.e. the dependence of the tension of the flux tube on its color content. We do this by building an extended baryon, where a fraction ν of the total of N quarks is removed to a finite distance.

Contents

Abstract	iii
1 Introduction and History	1
1.1 General Covariance of the Born-Infeld Action	6
1.2 Non-Abelian Generalizations of B-I	10
2 Applications of B-I Action to the 3-brane	13
2.1 Electrostatics on the threebrane	13
2.2 Dynamics: Dirichlet Boundary Conditions	16
2.3 Dynamics: Neumann Boundary Conditions	20
2.3.1 The Lagrangian and the equations	22
2.3.2 Neumann boundary conditions and dipole radiation	24
2.4 Brane-anti-Brane annihilation	29
2.4.1 The Two Static Configurations	30
2.4.2 Annihilation by Tunneling.	34
3 Born-Infeld Action and AdS/CFT Correspondence	35
3.1 Baryons in AdS	36
3.1.1 The Setup	37
3.1.2 Supersymmetry Issues	40
3.1.3 <i>AdS</i> background: Born-Infeld Baryons	43
3.2 Hanany-Witten effect in the full D3-brane metric background	50
3.3 The Baryon in Three Dimensions	57
3.3.1 Worldvolume Action and Equations of Motion	58
3.3.2 The Point Baryon	63
3.3.3 The Split Baryon: Color Dependence of the String Tension	66
Conclusion	72
Acknowledgements	72
Bibliography	73

Chapter 1

Introduction and History

Research into various aspects of D-branes in the past few years has become synonymous with the New String Theory. Beginning with the first work by Dai, Leigh and Polchinski in 1989 [3], and the key discovery by Polchinski [5] of the fact that D-branes carry RR charges led to an incredible amount of activity surrounding branes. D-branes, in particular the D2-brane and the NS5-brane are presently thought to be the fundamental objects of M-theory, which is conjectured to incorporate all the known species of string theory, plus the 11-dimensional supergravity. An important milestone was the construction of the corresponding supergravity solutions by G. Horowitz and A. Strominger [41]. This work itself built on the previous construction of the SUGRA solution for an infinite fundamental string by Dabholkar and Harvey [22].

The Born-Infeld action, sometimes also referred to as Dirac-Born-Infeld [1, 2] action is the effective action for low-energy degrees of freedom of the D-brane [4]. Even before that, the consistency of the σ -model for the world-sheet of the string was shown to require the background field to be described by BI action [23], just like in the general curved background requiring consistency of string theory leads to the Einstein-Hilbert action [24]. It should come as no surprise then, that BI is also invariant under general coordinate transformations, in fact it can be thought of as a theory with a more general metric, where the anti-symmetric part of the metric tensor is identified

with the electromagnetic field. This was the thinking of Born and Infeld [1] when they presented the final version of their modified electrodynamics. The original motivation was to get a better behaved theory, one that would not have the Coulomb self-energy divergence, etc... Also one might hope that the corresponding quantum field theory might be better behaved too, but progress is of course hindered by the fact that the action contains an infinite number of unrenormalisable interactions.

As explained above, the key difference with previously known p-branes and supermembranes [18, 20, 19] is the inclusion of a worldvolume electromagnetic field. This field corresponds on the string theory side to virtual states of an open string, where both ends are fixed to move in the worldvolume of the brane.

The starting point for this thesis is the paper by Callan and Maldacena [6], hereafter referred to as CM. They, noting that most treatments of D-branes were done using the linearized theory, undertook to fully account for the specific non-linearities of the Born-Infeld *super-electrodynamics*. The static features of intersecting branes are determined by SUSY and BPS arguments, however dynamical issues have to be explored using the full Born-Infeld action. They construct, first and foremost, the solution for a fundamental string ending on a D-brane, in which the junction-point of the string manifests itself as a point Coulomb charge in the world-volume of the brane. They also find a non-BPS solution corresponding to a brane and an anti-brane joined by e.g. a fundamental string.

This thesis is based on a series of papers that arose directly out of the approach Callan and Maldacena took in their paper. For the sake of convenience I list these papers in the order in which they are presented in this thesis:

- “Neumann Boundary Conditions from Born-Infeld Dynamics,”
by K. Savvidy, G. Savvidy, [hep-th/9902197](#)
- “Brane Death via Born-Infeld String”, by K. Savvidy, [hep-th/9810163](#)

- “Baryons and String Creation from the Fivebrane Worldvolume Action,”
by C.G. Callan, A. Guijosa, K. G. Savvidy, [hep-th/9810092](#)
- “Baryons and Flux Tubes in Confining Gauge Theories from Brane Actions,”
by C.G. Callan, A. Guijosa, K. G. Savvidy, O. Tafjord, [hep-th/9902197](#)

I have used the texts of these papers to large extent verbatim, especially in the case of the latter two papers, in this thesis.

In Chapter 1 I review some general facts about the Born-Infeld action. In particular, section 1.1 deals with the two possible representations of the action, the manifestly generally covariant one, and the dimensionally reduced version which is necessarily in the “static” gauge. Section 1.2 discusses briefly the subject that hasn’t received full development as yet, that of non-Abelian generalization of the B-I action.

In Chapter 2 I present some applications of ideas from CM to threebrane physics. Specifically, sections 2.2 and 2.3 show how Polchinski’s open string boundary conditions arise dynamically from the B-I treatment of the F-string attached to a D3-brane. In CM it was shown that excitations which are normal to both the string and the 3-brane behave as if they had Dirichlet boundary conditions at the point of attachment. We show that certain excitations of the F-string/D3-brane system can be shown to obey Neumann boundary conditions by considering the Born-Infeld dynamics of the F-string (viewed as a 3-brane cylindrically wrapped on an S_2). In CM it was shown that excitations which are normal to both the string and the 3-brane behave as if they had Dirichlet boundary conditions at the point of attachment. In [8] we show that excitations which are coming down the string with a polarization along a direction parallel to the brane are almost completely reflected just as in the case of all-normal excitations, but the end of the string moves freely on the 3-brane, thus realizing Polchinski’s open string Neumann boundary condition dynamically. In the low energy limit $\omega \rightarrow 0$, i.e. for wavelengths much larger than the string scale only a small fraction $\sim \omega^4$ of

the energy escapes in the form of dipole radiation. The physical interpretation is that a string attached to the 3-brane manifests itself as an electric charge, and waves on the string cause the end point of the string to freely oscillate and therefore produce electromagnetic dipole radiation in the asymptotic outer region.

Section 2.4 contains the calculation of the brane-anti-brane potential, which can be used to capture some new features of the quasi-classical tunneling of the brane-anti-brane pair joined by an F-string. This is of relevance to a subject that has since attracted certain attention, the brane-anti-brane annihilation: see e.g. A. Sen, "Tachyon condensation.." and E. Witten "D-branes and K-theory". Our calculation shows that for a distance between the branes that is larger than some critical distance, determined by the string coupling, the stretched string is indeed quasi-stable, while for shorter distances it is tachyonic.

The attraction between the branes causes them to approach and at some point to tunnel, because the action of the bounce solution goes to zero. The energy of the solution at the top of the barrier, the sphaleron, goes like $\sim D^3$ for large separations D , while the energy of the string is proportional to its length D .

Chapter 3 has a slightly different flavor. There, the B-I action is used to describe a fivebrane placed in the supergravity background of N coincident D3-branes. In the near-horizon limit, according to Witten, the background five-form RR field induces N units of electric charge on the fivebrane, which should be interpreted as N fundamental strings attached to it. These strings play the role of quarks in the AdS/CFT correspondence, and the configuration as a whole is interpreted as a color neutral baryon of $SU(N)$ *super*-YM theory.

In essence, B-I is known to incorporate corrections to string theory to all orders in α' , and thus allows us to construct an essentially non-perturbative object on the gauge theory side: the baryon. In addition, this approach is self consistent, since B-I action is only valid for slowly varying fields (the action does not contain derivative-dependent

corrections to the effective string action). Our solutions have fields that are everywhere smooth thus ensuring the consistency of our description.

The extension of these to the full D3 metric results in a nice classical description of the Hanany-Witten phenomenon, whereby strings are created when a flat D5-brane is pulled through the threebrane stack. A surprising byproduct is the configuration where $N/2$ strings are stretched to the threebranes on either side, and change their orientation when one crosses the threebrane. Thus the total change in the number of strings is N , as expected. This configuration¹, is characterized by zero force on the 5-brane, as the attraction due to the tension of the string is exactly balanced by electrostatic repulsion. These considerations seem to suggest the actual existence of the $1/2$ string state, the proper interpretation of which is at present not clear.

In the section 3.3 we use near-horizon geometry of non-extremal D3-branes to find embeddings of a D5-brane which describe baryonic states in three-dimensional QCD. In particular, we construct solutions corresponding to a baryon made of N quarks, and study what happens when some fraction ν of the total number of quarks are bodily moved to a large spatial separation from the others. The individual clumps of quarks are represented by Born-Infeld string tubes obtained from a D5-brane whose spatial section has topology $\mathbf{R} \times \mathbf{S}^4$. They are connected by a confining color flux tube, described by a portion of the fivebrane that runs very close and parallel to the horizon. We find that this flux tube has a tension with a nontrivial ν -dependence (not previously obtained by other methods).

We also discuss related questions including binding energies, string creation, and the appearance of new energy scales.

¹It was found for the case of 0-brane in [52].

1.1 General Covariance of the Born-Infeld Action

This section closely follows [35] by M. Aganagic, C. Popescu and J.H. Schwarz and [7] by G.W. Gibbons in the treatment of general covariance of the Born-Infeld action. Born and Infeld [1] realized the final version of their non-linear electrodynamics through a manifestly covariant action. In modern language this can be expressed by saying that the world-volume theory of the brane is described by the action

$$S_{(p)} = -\frac{1}{(2\pi)^p g_s} \int d^{p+1} \sigma \sqrt{-\det(G_{\mu\nu} + F_{\mu\nu})} \quad (1.1)$$

where F is the world-volume electromagnetic field strength, measured in units in which $2\pi\alpha' = 1$. G is the induced metric on the brane

$$G_{\mu\nu} = \eta_{mn} \partial_\mu X^m \partial_\nu X^n. \quad (1.2)$$

The action is invariant under arbitrary diffeomorphisms of the world-volume. One way of fixing this freedom is to adopt the so-called “static gauge” for which the world-volume coordinates are equated with the first $p + 1$ space-time coordinates:

$$X^\mu \equiv \sigma^\mu, \quad \mu = 0, 1, \dots, p. \quad (1.3)$$

This “static gauge” description is most convenient if the brane is indeed positioned along those directions.

The rest of the coordinates become world-volume fields

$$X^m \equiv \phi^m, \quad m = p + 1, \dots, 9. \quad (1.4)$$

The B-I action becomes

$$S'_{(p)} = -\frac{1}{(2\pi)^p g_s} \int d^{p+1} \sigma \sqrt{-\det(\eta_{\mu\nu} + \partial_\mu \phi^i \partial_\nu \phi^i + F_{\mu\nu})}. \quad (1.5)$$

Note that this is in some sense a modification of pure B-I: it has extra scalar fields ϕ .

Another way of obtaining the same is to dimensionally reduce from 10D flat-space B-I by assuming that fields depend only on the first $p + 1$ coordinates, where p is the number of space dimensions of the brane. In this picture the extra components of the gauge field, $A_{p+1} \dots A_9$ come to represent the massless transverse excitations $\phi_{p+1} \dots \phi_9$. In fact, they are the Goldstone bosons associated with spontaneously broken translational symmetries. In this way one gets to compute a 10×10 determinant instead of a 4×4 determinant. The general coordinate invariance is not apparent in this approach, and in fact it is hard or impossible to use if a more general parametrization of the brane is desired, or the brane is immersed into an already curved background. A simple illustration of the equivalence of this two forms of the action is to consider an electrostatic case, with only one scalar field excited. The corresponding determinants are²

$$\begin{pmatrix} -1 & E_1 & E_2 & E_3 & 0 \\ -E_1 & 1 & 0 & 0 & \partial_1 \phi \\ -E_2 & 0 & 1 & 0 & \partial_2 \phi \\ -E_3 & 0 & 0 & 1 & \partial_3 \phi \\ 0 & -\partial_1 \phi & -\partial_2 \phi & -\partial_3 \phi & 1 \end{pmatrix} \text{ vs. } \begin{pmatrix} -1 & E_1 & E_2 & E_3 \\ -E_1 & 1 + \partial_1 \phi^2 & \partial_1 \phi \partial_2 \phi & \partial_1 \phi \partial_3 \phi \\ -E_2 & \partial_1 \phi \partial_2 \phi & 1 + \partial_2 \phi^2 & \partial_2 \phi \partial_3 \phi \\ -E_3 & \partial_1 \phi \partial_3 \phi & \partial_2 \phi \partial_3 \phi & 1 + \partial_3 \phi^2 \end{pmatrix} \quad (1.6)$$

It is easy to see that the two are equivalent by simple row and column subtractions.

The discussion so far, and in most applications, concerns the “bosonic” action. However it is important to remember that it is a SUSY theory that we are dealing with. Some non-trivial issues are presented in the paper [35] by Aganagic, Popescu and Schwarz. In the first, manifestly general-covariant representation, the supersymmetric theory consists of X^m , the flat 10-dimensional space coordinates; the $U(1)$ gauge field A_μ on the world-volume; and a pair of Majorana-Weyl spinors θ_1 and θ_2 . These spinors are of the same or opposite chirality depending on whether we consider type IIA or IIB theory (even/odd p). The resulting theory possesses a high degree of symmetry:

- global super-Poincare group in 10D

²We specialize to the case of three-brane here.

- local general coordinate invariance
- local fermionic “kappa” symmetry
- local U(1) gauge invariance

In the gauge-fixed version the action is quite simple, and versions for different p’s can be obtained from a single 10D Action by dimensional reduction:

$$- \int d^{10} \sigma \sqrt{-\det \left(\eta_{\mu\nu} + F_{\mu\nu} - 2\bar{\lambda}\Gamma_{\mu}\partial_{\nu}\lambda + \bar{\lambda}\Gamma^{\rho}\partial_{\mu}\lambda \cdot \bar{\lambda}\Gamma_{\rho}\partial_{\nu}\lambda \right)}. \quad (1.7)$$

Here λ is the one surviving Majorana-Weyl spinor, with the second one having been set to zero. The number of physical degrees of freedom is 8 for the gauge field, and for the fermions the 32 original components are reduced in half by local kappa symmetry and again in half by the equations of motion.

Among the symmetries of the gauge-invariant action are the global translations $\delta X^m = a^m$. Decomposing these into translations a^{μ} tangent to the brane and a^i normal to the brane, we have

$$\begin{aligned} \delta X^{\mu} &= a^{\mu} + \xi^{\rho}\partial_{\rho}X^{\mu} &= a^{\mu} + \xi^{\mu} = 0, \\ \delta\phi^i &= a^i + \xi^{\rho}\partial_{\rho}\phi^i &= a^i - a^{\rho}\partial_{\rho}\phi^i. \end{aligned} \quad (1.8)$$

In these equations a compensating general coordinate transformation is used, with a parameter $\xi^{\mu} = -a^{\mu}$, in order to preserve the $X^{\mu} = \sigma^{\mu}$ gauge. One can also infer the induced transformation of the gauge field A_{μ} :

$$\delta A_{\mu} = -a^{\rho}F_{\rho\mu} = -a^{\rho}\partial_{\rho}A_{\mu} + a^{\rho}\partial_{\mu}A_{\rho} \quad (1.9)$$

This broke down into two pieces: first, the translation proper; second, a gauge transformation with parameter χ , such that $\chi = a^{\rho}A_{\rho}$.

In order to clarify the meaning of these formulas it is useful to specialize to the cases of completely normal and completely tangent translations. For small translations a^i , $\xi^{\mu} = 0$ and thus:

$$\delta X^{\mu} = 0, \quad \delta\phi^i = a^i, \quad \text{and} \quad \delta A_{\mu} = 0. \quad (1.10)$$

This is just a trivial shift, but nonetheless a significant symmetry of the theory: it corresponds to spontaneously broken (by the presence of the brane) translational symmetry normal to the brane, and ϕ^i are the associated Goldstone bosons.

The second case, in this context, is the unbroken tangent translations a^μ . The formulas read:

$$\delta X^\mu = 0 \ , \ \text{thus} \ \xi^\mu = -a^\mu \ . \quad (1.11)$$

The dynamical fields transform as

$$\begin{aligned} \delta \phi^i &= -a^\mu \partial_\mu \phi^i \ , \\ \delta A_\nu &= -a^\mu \partial_\mu A_\nu + a^\mu \partial_\nu A_\mu \ . \end{aligned} \quad (1.12)$$

We will use an ansatz inspired by these formulas to describe tangent fluctuations of the F-string/D-brane configuration in section 2.3. In that case the translation parameter a^μ is no longer constant, but is position dependent. In fact, it should be clear from the form of the previous expressions that a^μ is presumed small. Nevertheless the idea of a compensating general coordinate transformation remains useful to make sure that the fields, i.e. ϕ and A_μ represent the desired bending of the surface of the brane.

For completeness we also quote the SUSY transformations of the supersymmetric version of B-I theory

$$\begin{aligned} \Delta \bar{\lambda} &= \bar{\epsilon}_1 + \bar{\epsilon}_2 \zeta^{(p)} + \xi^\mu \partial_\mu \bar{\lambda} \\ \Delta \phi^i &= (\bar{\epsilon}_1 - \bar{\epsilon}_2 \zeta^{(p)}) \Gamma^i \lambda + \xi^\mu \partial_\mu \phi^i \\ \Delta A_\mu &= (\bar{\epsilon}_2 \zeta^{(p)} - \bar{\epsilon}_1) (\Gamma_\mu + \Gamma_i \partial_\mu \phi^i) \lambda \\ &\quad + \left(\frac{1}{3} \bar{\epsilon}_1 - \bar{\epsilon}_2 \zeta^{(p)} \right) \Gamma_m \lambda \bar{\lambda} \Gamma^m \partial_\mu \lambda + \xi^\rho \partial_\rho A_\mu - \partial_\mu \xi^\rho A_\rho \ , \end{aligned} \quad (1.13)$$

where ξ , as explained above, is the parameter of a compensating general coordinate transformation that restores the static gauge, i.e. $\delta \bar{\theta}_2 = 0$ and $\delta X^\mu = 0$ under these transformations. From these requirements it follows that

$$\xi^\mu = (\bar{\epsilon}_2 \zeta^{(p)} - \bar{\epsilon}_1) \Gamma^\mu \lambda. \quad (1.14)$$

Here and above $\zeta^{(p)}$ represents a matrix, exact form of which can be found in [35], suffice it to say that key property of it is $\zeta^{(p)}\tilde{\zeta}^{(p)} = \tilde{\zeta}^{(p)}\zeta^{(p)} = 1$.

1.2 Non-Abelian Generalizations of B-I

The efforts to find a generalisation of B-I action to the non-Abelian case are motivated by the need to effectively describe N coincident branes, where the $U(1)^N$ symmetry is enhanced to $U(N) = SU(N) \times U(1)$. This can be understood as the effect of the massive vector bosons (open strings connecting the different branes) becoming light/massless as the branes are moved closer.

The earliest proposals entail formally expanding the ordinary B-I Lagrangian in powers of F , then taking a simple [25], an anti-symmetrized [26], or a symmetrized [27] trace over the group indices. This is necessary because if the Determinant is understood to be taken over the Lorentz indices, then the only way to deal with the color index is to expand the expression under the square root, and only then deal with the color index. Below we present a recent proposal [38] to compute the determinant with respect to combined Lorentz and color indices.

The matters are further complicated by the difficulty to disentangle the derivative terms ∂F which arise in the perturbative expansion from the commutator terms, as can be seen from the following identity for a commutator of covariant derivatives:

$$[D_m, D_n]F_{kl} = [F_{mn}, F_{kl}] . \quad (1.15)$$

Tseytlin proposed to resolve this by treating all terms that can be written as a commutator to be part of the “derivative dependent” part of the effective action. In this way the F^3 terms in the open bosonic string effective action can be dropped, and the F^4 terms differ with the superstring case by only a commutator term also. In fact, these terms can be written as

$$\text{Tr} \left(\frac{4}{3} i \alpha' F_{mn} [F_{ml}, F_{nl}] \right) + 2 \alpha'^2 \text{Tr} \left(F^{mn} F^{rl} [F_{mn}, F_{rl}] \right) \quad (1.16)$$

and thus belong according to his definition to the covariant derivative part of L_{eff} . Tseytlin then proceeds to give a general argument for taking the symmetrized trace in the formal expansion of the Abelian B-I action. He gets, to quadratic order

$$\begin{aligned} L_{NBI} &= \text{STr} \sqrt{\det(\delta_{mn} + F_{mn})} = \text{STr} \left[F_{mn}^2 + \frac{1}{2}(2\pi\alpha')^2(F^4 - \frac{1}{4}(F^2)^2) + O(\alpha'^3) \right] \\ &= \text{Tr} \left[F_{mn}^2 - \frac{1}{3}(2\pi\alpha')^2(F_{mn}F_{rn}F_{ml}F_{rl} + \frac{1}{2}F_{mn}F_{rn}F_{rl}F_{ml} - \right. \\ &\quad \left. \frac{1}{4}F_{mn}F_{mn}F_{rl}F_{rl} - \frac{1}{8}F_{mn}F_{rl}F_{mn}F_{rl} + O(\alpha'^4) \right] \end{aligned}$$

In the paper by W. Taylor IV and A. Hashimoto [39] this functional was checked against e.g. the excitation spectrum of open strings on branes intersecting at an angle. They show that this action can be used to resolve some but not all of the discrepancies.

A more recent proposal by J. Park [38] is in some sense very natural, similar ideas were circulating in early '97, i.e. to combine the spacetime and the group indices into one and then compute a single determinant. This is in fact typical of YM effective actions: see for example the original computation of the pure YM effective action by G. Savvidy [29]. There too it is computed by exponentiating the matrix in order to trade the determinant for a trace (see below). F and G become matrices with a double index as follows:

$$F_{\mu\alpha, \nu\beta} \equiv F_{\mu\nu}^a T_{\alpha\beta}^a \quad (1.17)$$

and

$$g_{\mu\nu} \longrightarrow G_{\mu\alpha, \nu\beta} \equiv g_{\mu\nu} \delta_{\alpha\beta} . \quad (1.18)$$

After defining a convenient subsidiary matrix $\mathcal{F} \equiv G^{-1}F$, Park proposes the following non-Abelian generalization of the Born-Infeld Lagrangian

$$\begin{aligned} L &= 2N\kappa^{-2} \left((\text{Det}(G + \kappa F))^{\frac{1}{2N}} - \sqrt{|g|} \right) \\ &= 2N\kappa^{-2} \sqrt{|g|} \left(\exp \left(\sum_{n=1}^{\infty} \frac{(-1)^{n-1}}{n} \frac{1}{2N} \kappa^n \text{Tr} \mathcal{F}^n \right) - 1 \right) \\ &= \sqrt{|g|} \left(-\frac{1}{2} \text{Tr} \mathcal{F}^2 + \frac{1}{3} \kappa \text{Tr} \mathcal{F}^3 - \frac{1}{4} \kappa^2 \text{Tr} \mathcal{F}^4 + \frac{1}{16N} \kappa^2 (\text{Tr} \mathcal{F})^2 + \dots \right) \end{aligned} \quad (1.19)$$

where $\kappa = 2\pi\alpha'$ is a coupling constant. The $2N$ -th order root is inserted in order to insure that for large F the action is bounded from above by a fixed power of F , equal to $p + 1$ and independent of N . The second, related reason is that $\text{Det } |G| = |g|^N$.

In the $SU(2)$ case it is possible to compute the determinant in closed form. In Euclidean space:

$$\begin{aligned} \mathbb{L}_E &= 4\kappa^{-2} \left[1 - \left(1 - \frac{1}{4}\kappa^2 \text{Tr} F^2 + \frac{1}{6}\kappa^3 \text{Tr} F^3 - \frac{1}{8}\kappa^4 \text{Tr} F^4 + \frac{1}{32}\kappa^4 (\text{Tr} F^2)^2 \right)^{\frac{1}{2}} \right] \\ &= 4\kappa^{-2} \left[1 - \left(1 - \frac{1}{8}\kappa^2 F_{\mu\nu}^a F_{\mu\nu}^a - \frac{1}{24}\kappa^3 \epsilon^{abc} F_{\mu\nu}^a F_{\nu\lambda}^b F_{\lambda\mu}^c + \frac{1}{128}\kappa^4 (F_{\mu\nu}^a F_{\mu\nu}^a)^2 \right. \right. \\ &\quad \left. \left. - \frac{1}{32}\kappa^4 F_{\mu\nu}^a F_{\nu\lambda}^a F_{\lambda\rho}^b F_{\rho\mu}^b + \frac{1}{64}\kappa^4 F_{\mu\nu}^a F_{\nu\lambda}^b F_{\lambda\rho}^a F_{\rho\mu}^b \right)^{\frac{1}{2}} \right] \end{aligned} \quad (1.20)$$

Further in the same paper an instanton solution is constructed through a combination of the usual ansatz with some numerical integration. The total action of this solution seems to have the correct value $8\pi^2$.

In conclusion we would like to mention that despite certain progress, the issues surrounding the nonabelian generalisation of the B-I action are still unclear, and in any case actual applications to brane physics are lacking. However we will be able to sidestep the ambiguities pointed out above when we consider in Chapter 3 a fivebrane in the essentially non-Abelian background of N D3-branes. There the dynamics of the fivebrane is captured by the usual abelian worldvolume gauge field, which it might be possible to interpret as the *a-la* t'Hooft Abelian projection of the $SU(N)$ fields.

Chapter 2

Applications of B-I Action to the 3-brane

2.1 Electrostatics on the threebrane

The starting point for this thesis is the paper by Callan and Maldacena [6], hereafter referred to as CM. They, noting that most treatments of D-branes were done using the linearized theory, undertook to fully account for the specific non-linearities of the Born-Infeld *super-electrodynamics*. The static features of intersecting branes are determined by SUSY and BPS arguments, however dynamical issues have to be explored using the full Born-Infeld action. They construct, first and foremost, the solution for a fundamental string ending on a D-brane, in which the end-point of a string manifests itself as a point Coulomb charge in the world-volume of the brane. They also find a non-BPS solution corresponding to a brane and an anti-brane joined by e.g. a fundamental string.

We repeat their arguments for the construction. Starting from a 10-dimensional B-I action and dimensionally reducing to 3+1 dimensions we need to compute the action

$$S = -\frac{1}{g_p} \int d^4x \sqrt{-\text{Det}(G_{\mu\nu} + F_{\mu\nu})} \quad , \text{ with } g_p = (2\pi)^3 g_s \quad (2.1)$$

where only one of the 6 available scalars is excited. The actual determinant that needs

to be computed is

$$\begin{aligned}
-\text{Det} &= \begin{bmatrix} -1 & E_1 & E_2 & E_3 & \partial_0\phi \\ -E_1 & 1 & B_3 & -B_2 & \partial_1\phi \\ -E_2 & -B_3 & 1 & B_1 & \partial_2\phi \\ -E_3 & B_2 & -B_1 & 1 & \partial_3\phi \\ -\partial_0\phi & -\partial_1\phi & -\partial_2\phi & -\partial_3\phi & 1 \end{bmatrix} = \\
&= 1 + \vec{B}^2 - \vec{E}^2 - (\vec{E} \cdot \vec{B})^2 - (\partial_0\phi)^2(1 + \vec{B}^2) + (\vec{\partial}\phi)^2 \\
&\quad + (\vec{B} \cdot \vec{\partial}\phi)^2 - (\vec{E} \times \vec{\partial}\phi)^2 + 2\partial_0\phi (\vec{B} \cdot [\vec{\partial}\phi \times \vec{E}])
\end{aligned} \tag{2.2}$$

This expression was computed by myself in June 1997, and a slightly less general version can be found in the review by Gibbons [7]. In CM supersymmetry analysis is used to find the required solution. This is possible because for supersymmetric BPS configurations the value of the B-I action coincides with the linear theory. Thus one can find the required solution by constructing one for the linear theory and then checking that it satisfy the equations of motion of the full non-linear theory.

This is done in more detail in section 2.4 for the more general, non-BPS static configuration that corresponds to a threebrane and anti-brane joined by a fundamental string. The limit of a single brane with an infinite string attached is simply the limit of infinite separation between the branes, or $A \rightarrow B$ whereby A and B are the integration constants for the electric and scalar fields respectively.

In order to use BPS arguments to find solutions of the three-brane worldvolume gauge theory which have the interpretation of string ending on a three-brane, we, after CM, consider the supersymmetry variation of the gaugino

$$\delta\chi = \Gamma^{mn} F_{mn}\epsilon \tag{2.3}$$

where mn are ten-dimensional indices. This is the dimensional reduction description, so that the coordinate and electromagnetic massless excitations are both part of the same ten-dimensional electromagnetic field strength F_{mn} as is the case in the above matrix (2.2).

We would like to find a solution to (2.3) for which $\delta\chi = 0$ for some ϵ . This is not possible for a point charge Coulomb gauge field alone. However we can also excite one of the transverse scalar fields such that $\phi = A_0 = \frac{c}{r}$. This is clearly a solution of the linearized (Laplace) equation. Taking into account that $F_{0r} = F_{09}$, the supersymmetry variation (2.3) reduces to

$$(\Gamma^{0r} + \Gamma^{9r})\epsilon = 0 \quad \Rightarrow \quad (\Gamma^0 + \Gamma^9)\epsilon = 0 \quad \Rightarrow \quad (1 + \Gamma^{09})\epsilon = 0 . \quad (2.4)$$

Therefore a SUSY spinor, polarized along the directions of the worldsheet (09) preserves half the supersymmetry. This is the same spinor as in Dabholkar and Harvey, even though here the situation is complicated by the simultaneous presence of the threebrane and the fact that the string is half-infinite. In section 3.1.2 we present a more complete explanation of the conditions imposed on SUSY variations in the presence of various branes. In the context of type IIB SUGRA there is a further condition due to the presence of the threebrane, which can be written as

$$\Gamma^{0123}\epsilon = i\epsilon . \quad (2.5)$$

One can find the charge quantization condition in CM, and determine the value of c in the solution as $c = \pi g$. Thus the solution finally is

$$\phi = \frac{c}{r} , \quad A_0 = \frac{c}{r} , \quad \vec{E} = -\frac{c}{r^2}\vec{e}_r . \quad (2.6)$$

Further, CM show that this infinite spike should be interpreted as an infinite fundamental string. First, one can derive the Hamiltonian for the static configurations that we have been so far considering

$$H = \frac{1}{g_p} \sqrt{(1 + (g_p \vec{\Pi})^2)(1 + (\vec{\nabla} X)^2) - (g_p \vec{\Pi} \times \vec{\nabla} X)^2} . \quad (2.7)$$

Using this expression, one can confirm that the energy per unit length of the “string-like” object is indeed equal to that of a fundamental string $dE = \frac{1}{2\pi}d\phi$ or $T = \frac{1}{2\pi}$.

In the next two sections it is shown that this picture survives a more detailed scrutiny, by considering the dynamical behavior of this configuration under small perturbations. Polchinski's open string boundary conditions (Dirichlet or Neumann) arise from the full Born-Infeld theory dynamically.

2.2 Dynamics: Dirichlet Boundary Conditions

Having presented the static B-I charge configuration, we go on to show that small excitations which propagate along the string, in the low-energy limit completely reflect with

- Dirichlet boundary conditions for excitations completely orthogonal to both the brane and the string, (this section)¹
- Neumann boundary conditions for normal excitations of the string that are polarized along one of the directions of the brane. (next section 2.3)

In order to consider the first case we need to add another scalar field into consideration. The convenient form of B-I is the dimensional reduction from 10D. The relevant determinant is

$$\begin{pmatrix} -1 & E_1 & E_2 & E_3 & 0 & \partial_0\zeta \\ -E_1 & 1 & 0 & 0 & \partial_1\phi & \partial_1\zeta \\ -E_2 & 0 & 1 & 0 & \partial_2\phi & \partial_2\zeta \\ -E_3 & 0 & 0 & 1 & \partial_3\phi & \partial_3\zeta \\ 0 & -\partial_1\phi & -\partial_2\phi & -\partial_3\phi & 1 & 0 \\ -\partial_0\zeta & -\partial_1\zeta & -\partial_2\zeta & -\partial_3\zeta & 0 & 1 \end{pmatrix} \quad (2.8)$$

Computing this and substituting the background values of the fields gives the following action for the dynamics of the ζ field:

$$L = - \int d^4x \sqrt{1 - (\partial_0\zeta)^2 + \left(1 + \frac{c^2}{r^4}\right) (\partial_i\zeta)^2} \quad (2.9)$$

¹This section is based on CM. Similar conclusions were reached in [36] by considering the covariant worldsheet action in the supergravity background of the threebrane.

The quadratic part, relevant to low-energy excitations is thus

$$L_q = \int d^4x \left[(\partial_0 \zeta)^2 - \left(1 + \frac{c^2}{r^4} \right) (\partial_i \zeta)^2 \right] \quad (2.10)$$

The resulting equation of motion is

$$- \left(1 + \frac{c^2}{r^4} \right) \partial_t^2 \zeta + r^{-2} \partial_r (r^2 \partial_r \zeta) = 0 . \quad (2.11)$$

In order to fully verify the correspondence with Polchinski's picture of D-brane dynamics via open fundamental strings, we have to look into the effective boundary condition for small fluctuations on the string (the $r \rightarrow 0$ region) imposed by the presence of the three-brane (the $r \rightarrow \infty$ region). In other words, we want the S-matrix connecting the two asymptotic regions.

We would like to look for solutions of definite energy (frequency). With the convenient redefinition of radius and coupling, the equation becomes

$$\left(1 + \frac{\kappa^2}{x^4} \right) \zeta + x^{-2} \frac{d}{dx} \left(x^2 \frac{d}{dx} \zeta \right) = 0 \quad \text{with } x = \omega r , \quad \text{and } \kappa = c\omega^2 . \quad (2.12)$$

At this point the problem gets a unified dependence on energy and coupling through the parameter $\kappa = c\omega^2 = \pi g_s \omega^2$. The equation has the interesting symmetry $r \leftrightarrow \kappa/r$ with $\zeta \leftrightarrow \zeta \cdot r$. This seems to imply that the interior asymptotic region, i.e. the string, is completely equivalent, or dual, to the outer region, i.e. the brane. Notice also the $1 + \frac{1}{r^4}$ factor, familiar from the SUGRA solution for the 3-brane. See also [36] for first hints of distance/radius duality in AdS. In order to treat the two asymptotic regions on an equal footing and to elucidate the fact that excitations "slow down" as $r \rightarrow 0$ it turns out to be convenient to introduce a new radial coordinate which measures the distance along the surface of the spike

$$\xi(x) = \int_{\sqrt{\kappa}}^x dy \sqrt{1 + \frac{\kappa^2}{y^4}} \quad (2.13)$$

and a new wavefunction designed such that the Laplacian preserves its usual form in this coordinate

$$\tilde{\zeta} = \zeta \cdot x \left(1 + \frac{\kappa^2}{x^4}\right)^{1/4}. \quad (2.14)$$

The coordinate behaves as $\xi \sim r$ in the outer region ($r \rightarrow \infty$) and $\xi \sim -\kappa/r$ on the string ($r \rightarrow 0$). The exact symmetry of the equation $r \leftrightarrow \kappa/r$ goes over to $\xi \leftrightarrow -\xi$. The equation, when written in this coordinate becomes just the free wave equation, plus a narrow symmetric potential at $\xi \sim 0$

$$-\frac{d^2}{d\xi^2}\tilde{\zeta} + \frac{5\kappa^2}{(x^2 + \kappa^2/x^2)^3}\tilde{\zeta} = \tilde{\zeta}. \quad (2.15)$$

The asymptotic wave functions can be constructed as plane waves in ξ ,

$$\tilde{\zeta} = e^{\pm i\xi(x)} \quad \zeta(x) = (x^4 + \kappa^2)^{-1/4} e^{\pm i\xi(x)},$$

or in the various limits:

$$\begin{aligned} x \rightarrow 0 & \quad \zeta \sim e^{\pm i\xi(x)}, \\ x \rightarrow \infty & \quad \zeta \sim \frac{1}{x} e^{\pm i\xi(x)}. \end{aligned}$$

These formulae give us the asymptotic wave function in the regions $\xi \rightarrow \pm\infty$, while around $\xi = 0$ ($x = \sqrt{\kappa}$) there is a symmetric repulsive potential which drops very fast $\sim 1/\xi^6$ on either side of the origin. The scattering is described by a single dimensionless parameter $\kappa = c\omega^2$, and in the limit of small frequency ω and/or coupling $c = \pi g_s$ the potential becomes narrow and high, and can be replaced by a δ -function with an equivalent area under the curve:

$$\begin{aligned} \mathcal{U} = \int V(\xi)d\xi &= \int_0^\infty \frac{5\kappa^2}{(x^2 + \kappa^2/x^2)^3} \sqrt{1 + \frac{\kappa^2}{x^4}} dx = \\ &= \frac{5\Gamma(5/4)^2}{3\sqrt{\pi\kappa}} = \frac{.77}{\sqrt{\kappa}} \end{aligned} \quad (2.16)$$

Thus,

$$\begin{aligned} V(\xi) &\sim \frac{.77}{\sqrt{\kappa}}\delta(\xi) & \kappa \rightarrow 0 \\ V(\xi) &\sim 0 & \kappa \rightarrow \infty \end{aligned} \quad (2.17)$$

Therefore the scattering matrix becomes almost independent of the exact form of the potential. We are interested in the behavior of the one-dimensional reflection and transmission amplitudes R and T . The result is that most of the amplitude is reflected back with a phase shift close to π , thus dynamically realizing the Dirichlet boundary condition in the low energy limit:

$$\begin{aligned}
\kappa \rightarrow 0 & & \kappa \rightarrow \infty \\
R \rightarrow -1 - 2i\sqrt{\kappa}/.77 & & R \rightarrow 0 \\
T \rightarrow -2i\sqrt{\kappa}/.77 & & |T| \rightarrow 1
\end{aligned} \tag{2.18}$$

We also learn from this that there is a smooth crossover from perfectly reflecting to perfectly transparent behavior as a function of the energy. Moreover WKB arguments show that the phase shift of the transmitted wave does not tend to zero, but to a constant of order unity.

However a more detailed analysis shows that δ -function approximation is not exactly correct, even in the limit of small κ . A better approximation is that of a square potential, which can be adjusted with two parameters to match both the integral of the potential and the integral of the square root of the potential, a quantity familiar from WKB underbarrier tunneling. The integral of the square root of the potential is

$$\begin{aligned}
\mathcal{S} = \int \sqrt{V(\xi)} d\xi &= \int_0^\infty \sqrt{\frac{5\kappa^2}{(x^2 + \kappa^2/x^2)^3}} \sqrt{1 + \frac{\kappa^2}{x^4}} dx = \\
& \frac{\sqrt{5}}{4}\pi = 1.75\dots
\end{aligned} \tag{2.19}$$

The detailed computation for a square potential gives the following approximate amplitudes, in terms of above introduced parameters \mathcal{S} and \mathcal{U}

$$\begin{aligned}
R \rightarrow -1 - \frac{2i\mathcal{S}}{\mathcal{U} \sinh \mathcal{S}} \\
T \rightarrow - \frac{2i\mathcal{S}}{\mathcal{U} \sinh \mathcal{S}}
\end{aligned} \tag{2.20}$$

Note that this coincides with (2.18) for $\mathcal{S} \rightarrow 0$. It also incorporates the correct exponential falloff in the wavefunction. As calculated above, our specific potential has

$\mathcal{S} \sim 1.75$. Thus the scaling of the amplitudes with κ is not essentially modified in this more detailed calculation, but only the exact coefficient is affected:

$$\begin{aligned} R &\rightarrow -1 - i0.92\sqrt{\kappa} \\ T &\rightarrow -i0.92\sqrt{\kappa} \end{aligned} \tag{2.21}$$

With this we conclude the analysis of completely transverse excitations of the string/brane system, and proceed in the next section to the considerably more complicated longitudinal excitations. As we will argue in that case, there are reasons to believe that the coefficient computed above should in fact be exactly equal to one.

2.3 Dynamics: Neumann Boundary Conditions

We would like to show that certain excitations of the F-string/D3-brane system obey Neumann (free) boundary conditions by considering the Born-Infeld dynamics of the F-string (viewed as a 3-brane cylindrically wrapped on an S_2). In the paper by Callan and Maldacena it was shown that excitations which are normal to both the string and the 3-brane behave as if they had Dirichlet boundary conditions at the point of attachment. Here we show that excitations which are coming down the string with a polarization along a direction parallel to the brane are almost completely reflected just as in the case of all-normal excitations, but the end of the string moves freely on the 3-brane, thus realizing Polchinski's open string Neumann boundary condition dynamically. In the low energy limit $\omega \rightarrow 0$, i.e. for wavelengths much larger than the string scale only a small fraction $\sim \omega^4$ of the energy escapes in the form of dipole radiation. The physical interpretation is that a string attached to the 3-brane manifests itself as an electric charge, and waves on the string cause the end point of the string to freely oscillate and therefore produce e.m. dipole radiation in the asymptotic outer region.

Dai, Leigh and Polchinski [3] introduced D-branes as objects on which strings can end, and required that the string have Dirichlet (fixed) boundary conditions for coordinates normal to the brane, and Neumann (free) boundary conditions for coordinate directions parallel to the brane [5, 3, 4]. It was shown in [6] (see previous section 2.2) that small fluctuations which are normal to both the string and the brane are mostly reflected back with a *phase shift* $\rightarrow \pi$ which indeed corresponds to Dirichlet boundary condition. See also [36] and [30] for a treatment of this problem, that relies on Nambu-Goto (or covariant) action for the worldsheet of the string placed in the supergravity background of the threebrane.

In this section we will show that P-wave excitations which are coming down the string with a polarization along a direction parallel to the brane are almost completely reflected just as in the case of all-normal excitations, but the end of the string moves freely on the 3-brane, thus realizing Polchinski's open string Neumann boundary condition dynamically. As we will see a superposition of excitations of the scalar x_9 and of the e.m. field reproduces the required behaviour, e.g. reflection of the geometrical fluctuation with a *phase shift* $\rightarrow 0$ (Neumann boundary condition)².

In addition we observe e.m. dipole radiation which escapes to infinity from the place where the string is attached to the 3-brane. We shall see that in the low energy limit $\omega \rightarrow 0$, i.e. for wavelengths much larger than the string scale a small fraction $\sim \omega^4$ of the energy escapes to infinity in the form of e.m. dipole radiation. The physical interpretation is that a string attached to the 3-brane manifests itself as an electric charge, and waves on the string cause the end point of the string to freely oscillate and therefore produce e.m. dipole radiation in the asymptotic outer region of the 3-brane.

Thus not only in the static case, but also in a more general dynamical situation the

²This problem was also considered in [30] where the e.m. field is integrated out to produce an effective lagrangian for the scalar field only. The other essential difference with us is that we consider *P*-wave modes of the scalar field which describe physical transverse fluctuations of the F-string and not the *S*-wave modes which do not correspond to physical excitations of the string.

above interpretation remains valid. This result provides additional support to the idea that the electron may be understood as the end of a fundamental string ending on a D-brane.

2.3.1 The Lagrangian and the equations

Let us write out the full Lagrangian (see section which contains both electric and magnetic fields, plus the scalar $x_9 \equiv \phi$

$$L = - \int d^4x \sqrt{\text{Det}} ,$$

$$\text{where } \text{Det} = 1 + \vec{B}^2 - \vec{E}^2 - (\vec{E} \cdot \vec{B})^2 - (\partial_0 \phi)^2 (1 + \vec{B}^2) + (\vec{\partial} \phi)^2$$

$$+ (\vec{B} \cdot \vec{\partial} \phi)^2 - (\vec{E} \times \vec{\partial} \phi)^2 + 2 \partial_0 \phi (\vec{B} \cdot [\vec{\partial} \phi \times \vec{E}]) \quad (2.22)$$

We will proceed by adding a fluctuation to the background values (2.6) :

$$\vec{E} = \vec{E}_0 + \delta \vec{E}, \quad \vec{B} = \delta \vec{B}, \quad \phi = \phi_0 + \eta .$$

Then keeping only terms in the *Det* which are linear and quadratic in the fluctuation we will get

$$\delta \text{Det} = \delta \vec{B}^2 - \delta \vec{E}^2 - (\vec{E}_0 \delta \vec{B})^2 - (\partial_0 \eta)^2 + (\vec{\partial} \eta)^2 \quad (2.23)$$

$$+ (\delta \vec{B} \vec{\partial} \phi)^2 - (\vec{E}_0 \times \vec{\partial} \eta)^2 - (\delta \vec{E} \times \vec{\partial} \phi)^2 - 2 (\vec{E}_0 \times \vec{\partial} \eta) (\delta \vec{E} \times \vec{\partial} \phi)$$

$$- 2 (\vec{E}_0 \delta \vec{E}) + 2 (\vec{\partial} \phi \vec{\partial} \eta)$$

Note that one should keep the last two linear terms because they produce additional quadratic terms after taking the square root. These terms involve the longitudinal polarization of the e.m. field and cancel out at quadratic order. The resulting quadratic Lagrangian is

$$2L_q = \delta \vec{E}^2 (1 + (\vec{\partial} \phi)^2) - \delta \vec{B}^2 + (\partial_0 \eta)^2 - (\vec{\partial} \eta)^2 (1 - \vec{E}_0^2) + \vec{E}_0^2 (\vec{\partial} \eta \cdot \delta \vec{E}) . \quad (2.24)$$

Let us introduce the gauge potential for the fluctuation part of the e.m. field as (A_0, \vec{A}) and substitute the values of the background fields from (2.6)

$$2L_q = (\partial_0 \vec{A} - \vec{\partial} A_0)^2 \left(1 + \frac{1}{r^4}\right) - (\vec{\nabla} \times \vec{A})^2 + (\partial_0 \eta)^2 - (\vec{\partial} \eta)^2 \left(1 - \frac{1}{r^4}\right) + \frac{1}{r^4} (\partial_0 \vec{A} - \vec{\partial} A_0) \cdot \vec{\partial} \eta . \quad (2.25)$$

The equations that follow from this lagrangian contain dynamical equations for the vector potential and for the scalar field, and a separate equation which represents a constraint. These equations in the Lorenz gauge $\vec{\partial} \vec{A} = \partial_0 A_0$ are

$$-\partial_0^2 \vec{A} \left(1 + \frac{1}{r^4}\right) + \Delta \vec{A} + \frac{1}{r^4} \vec{\partial} \partial_0 (A_0 + \eta) = 0 \quad (2.26)$$

$$-\partial_0^2 A_0 + \Delta A_0 + \vec{\partial} \frac{1}{r^4} \vec{\partial} (A_0 + \eta) - \vec{\partial} \frac{1}{r^4} \partial_0 \vec{A} = 0 \quad (2.27)$$

$$-\partial_0^2 \eta + \Delta \eta - \vec{\partial} \frac{1}{r^4} \vec{\partial} (A_0 + \eta) + \vec{\partial} \frac{1}{r^4} \partial_0 \vec{A} = 0 \quad (2.28)$$

Equation (2.27) is a constraint: the time derivative of the *lhs* is zero, as can be shown using the equation of motion (2.26).

Let us choose $A_0 = -\eta$. This condition can be viewed as (an attempt to) preserve the BPS relation which holds for the background: $\vec{E} = \vec{\partial} \phi$. Another point of view is that this fixes the general coordinate invariance which is inherent in the Born-Infeld lagrangian in such a way as to make the given perturbation to be normal to the surface. Of course transversality is insured automatically but this choice makes it explicit. The general treatment of this subject can be found in [35]. See also section 1.1 for a quick review of the issues involved.

With this condition the equations (2.27) and (2.28) become the same, and the first equation is also simplified:

$$-\partial_0^2 \vec{A} \left(1 + \frac{1}{r^4}\right) + \Delta \vec{A} = 0 , \quad (2.29)$$

$$-\partial_0^2 \eta + \Delta \eta + \vec{\partial} \frac{1}{r^4} \partial_0 \vec{A} = 0 . \quad (2.30)$$

This should be understood to imply that once we obtain a solution, A_0 is determined

from η , but in addition we are now obliged to respect the gauge condition which goes over to $\vec{\partial}\vec{A} = -\partial_0\eta$.

2.3.2 Neumann boundary conditions and dipole radiation

We will seek a solution with definite energy (frequency w) in the following form: \vec{A} should have only one component A_z , and η be an $l = 1$ spherical P -wave

$$A_z = \zeta(r) e^{-i\omega t} \quad , \quad \eta = \frac{z}{r} \psi(r) e^{-i\omega t}$$

The geometrical meaning of such a choice for η is explained in Fig 2.1, and the particular choice of z dependence corresponds to the polarization of the oscillations along the z direction of the brane. With this ansatz the equations become

$$\left(1 + \frac{1}{r^4}\right) \omega^2 \zeta + \frac{1}{r^2} \partial_r (r^2 \partial_r \zeta) = 0 \quad (2.31)$$

$$\frac{z}{r} \omega^2 \psi + \frac{z}{r} \frac{1}{r^2} \partial_r (r^2 \partial_r \psi) + \frac{z}{r} \frac{2}{r^2} \psi - i\omega \partial_z \left(\frac{\zeta}{r^4}\right) = 0 \quad , \quad (2.32)$$

with the gauge condition becoming $\partial_r \zeta = i\omega \psi$. It can be seen again, that the second equation follows from the first by differentiation. This is because the former coincides with the constraint in our ansatz.

Therefore the problem is reduced to finding the solution of a single scalar equation, and determining the other fields through subsidiary conditions. The equation 2.31 itself surprisingly turned out to be the one familiar from CM [6] for the transverse fluctuations. We refer the reader to section 2.2 for a detailed discussion of asymptotic wavefunctions and scattering amplitudes.

The asymptotic wave functions can be constructed as plane waves in the coordinate ξ , as introduced in Section 2.2,

$$\zeta(r) = (1 + r^4)^{-1/4} e^{\pm i\xi(r)} \quad ,$$

or in the various limits:

$$r \rightarrow 0 \quad \zeta \sim e^{\pm i\xi(r)} \quad ,$$

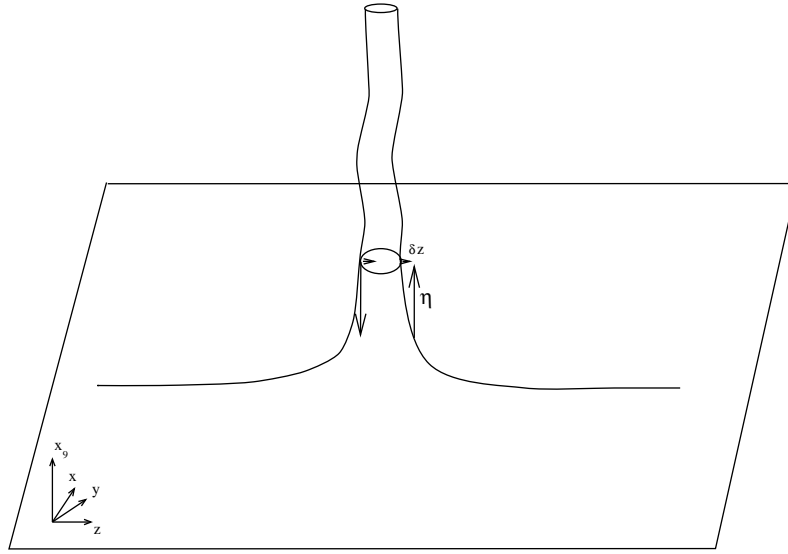

a

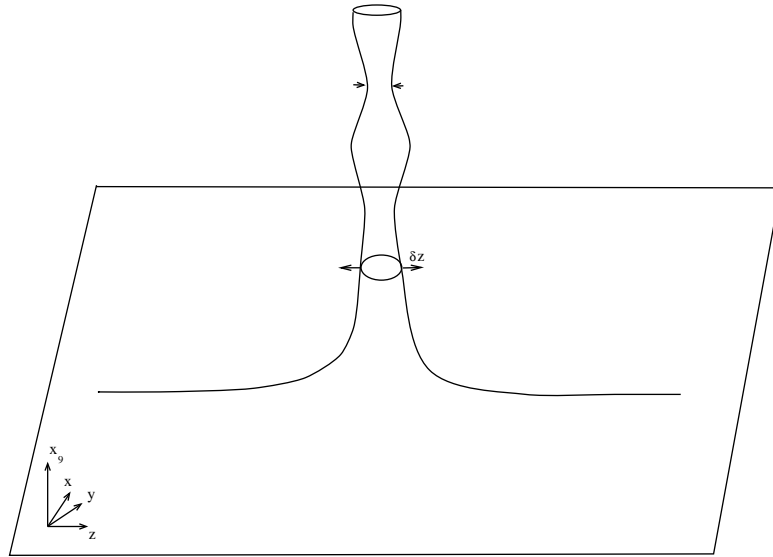

b

Figure 2.1: In order that all points on the S_2 section of the tube (which is schematically shown here as a circle) move all in the same direction \hat{z} by an equal distance δz , the field η has to take on different values at, say, opposite points of the S_2 . In effect, $\eta = \delta \frac{-1}{r} = \frac{1}{r^2} \hat{z} \delta z$. If, on the other hand, it is taken to be an S -wave (as in the paper [30]) that would correspond to Fig 2.1**b**, which at best is a problematic ‘internal’ degree of freedom of the tube.

$$r \rightarrow \infty \quad \zeta \sim \frac{1}{r} e^{\pm i\xi(r)} .$$

These formulae give us the asymptotic wave function in the regions $\xi \rightarrow \pm\infty$, while around $\xi = 0$ ($r = 1$) there is a symmetric repulsive potential which drops very fast $\sim 1/\xi^6$ on either side of the origin. The scattering is described by a single dimensionless parameter $\omega\sqrt{c}$, and in the limit of small ω and/or coupling $c = \pi g_s$ the potential becomes narrow and high, and can be replaced by a δ -function with an equivalent area $\sim \frac{1}{\omega\sqrt{g_s}}$ under the curve. Therefore the scattering matrix becomes almost independent of the exact form of the potential. The end result is that most of the amplitude is reflected back with a phase shift close to π , thus dynamically realizing the Dirichlet boundary condition in the low energy limit.

In order to obtain ψ (and η) we need to differentiate ζ with respect to r :

$$i\omega\psi = \frac{-1}{4} \frac{4r^3}{(1+r^4)^{5/4}} e^{\pm i\xi(r)} \pm \frac{i\omega}{(1+r^4)^{1/4}} \left(1 + \frac{1}{r^4}\right)^{1/2} e^{\pm i\xi(r)} . \quad (2.33)$$

Again it is easy to obtain the simplified limiting form:

$$\begin{aligned} r \rightarrow 0 \quad i\omega\psi &\sim \left(-r^3 \pm \frac{i\omega}{r^2}\right) e^{\pm i\xi(r)} \\ r \rightarrow \infty \quad i\omega\psi &\sim \left(\frac{-1}{r^2} \pm \frac{i\omega}{r}\right) e^{\pm i\xi(r)} \end{aligned}$$

This brings about several consequences for ψ . Firstly, it causes ψ to grow as $\sim 1/r^2$ as $r \rightarrow 0$. This is the correct behaviour because when converted to displacement in the z direction, it means constant amplitude:

$$\eta = \frac{z}{r}\psi = \delta \frac{-1}{r} = \frac{z}{r} \frac{1}{r^2} \delta z \Rightarrow \delta z \sim \text{const} . \quad (2.34)$$

Secondly, the i that enters causes the superposition of the incoming and reflected waves to become a cosine from a sine, as is the case for ζ waves. This corresponds to a 0 phase shift and implies Neumann boundary condition for the η wave (Figure 2.2).

Because of the ω factor in the gauge condition we need to be careful about normalizations, thus we shall choose to fix the amplitude of the δz (or η) wave to be

independent of ω . Then the magnitude of the e.m. field in the inner region becomes independent of ω as well. Combined with the transmission factor, proportional to $\omega\sqrt{c}$, this gives the following form of the dipole radiation field at infinity³

$$A_z \sim \frac{\omega\sqrt{\pi g_s}}{r} \zeta_0 e^{-i\omega t} = \frac{\omega e \zeta_0}{r} e^{-i\omega t} = \frac{\dot{d}}{r} \quad (2.35)$$

In order to make a comparison with Thomson formula $I = \frac{4}{3}\omega^4 e^2 A^2$ for the total power emitted by an oscillating dipole, we note that the agreement is guaranteed if the exact coefficient in (2.35) is equal to one. As shown at the end of the previous section, our approximate computation of the transmission amplitude gives this coefficient as $\sim .92$. Thus it is plausible that the magnitude of emitted power is in fact exactly equal to the elementary expectation from ordinary electrodynamics.

In conclusion, we need to analyze the outgoing scalar wave. This wave has both real and imaginary parts, the former is from differentiating the phase, while the latter is from the prefactor. The imaginary part is $\sim 1/r^2$ which drops faster than radiation. The real part does contribute to the radiation at spatial infinity, as can be shown from the integral of the energy density $\int (\partial_r \eta)^2 d^3r \sim \int \omega^4/r^2 \cdot 4\pi r^2 dr \sim \omega^4$. This is not altogether surprising, as we are dealing with a supersymmetric theory where the different fields are tied together. Thus the observer at spatial infinity will see both an electromagnetic dipole radiation field and a scalar wave. Interestingly, the direction dependences of the two conspire to produce a spherically symmetric distribution of the energy radiated.

The problem of longitudinal fluctuations was treated in [30], though not in a completely satisfactory way. There the scalar field was taken to be an S -wave, which as should be apparent from Fig 2.1**b**, does not correspond to the string oscillating as a whole. In addition the electromagnetic field was effectively integrated out, thus one cannot obtain the dipole radiation at spatial infinity.

³The unit of electric charge in our notation is $\pi g_s = e^2$. This is because of the scaling of the fields needed to get the U(1) action with $1/e^2$ in front of it.

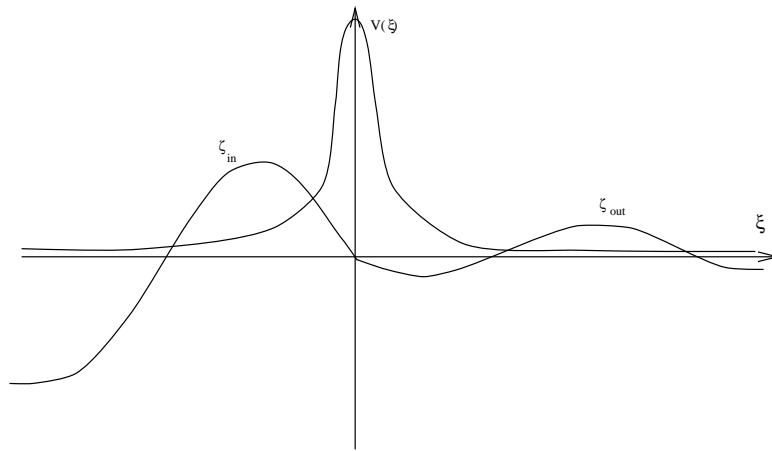

a

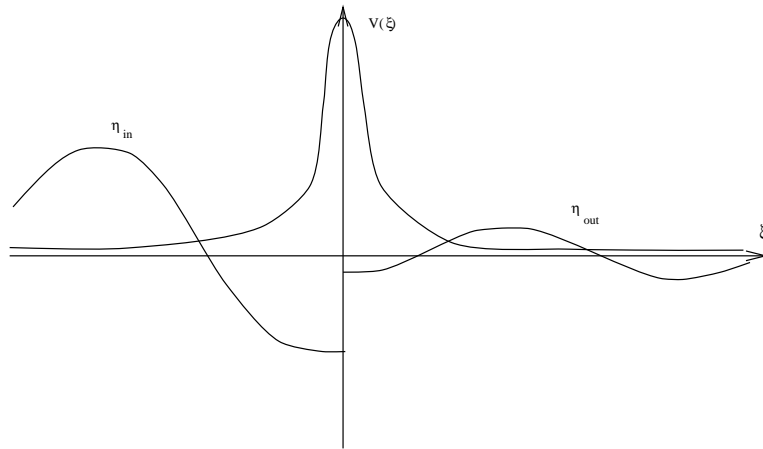

b

Figure 2.2: The figure 2.2**a** depicts the scattering of the ζ wave. Note the discontinuity in the derivative which is proportional to $1/\omega$. Figure 2.2**b** shows the scattering of the η wave. Being the derivative of ζ , it results in a discontinuity of the function itself, making it into a cosine, which means free (Neumann) boundary condition at $\xi = 0$.

2.4 Brane-anti-Brane annihilation

We revisit the solution of Born-Infeld theory which corresponds to a D3-brane and anti-brane joined by a (fundamental) string. The global instability of this configuration makes possible the semiclassical tunneling into a wide, short tube which keeps expanding out, thus annihilating the brane. This tunneling is suppressed exponentially as $\exp\{-\frac{S_{cl}}{g}\}$, where S_{cl} would be the action of the euclidean bounce solution, the construct that describes under-barrier tunneling in the WKB approximation. The attraction between the branes causes them to approach and annihilate at a finite distance D_{min} , where the potential barrier disappears. For large separations D , the energy of the solution at the top of the barrier, the sphaleron, goes like $\sim D^3$, while the energy of the string is proportional to its length D .

Callan and Maldacena [6] considered among other configurations the D3-brane and anti-brane joined by a (fundamental) string in the framework of Born-Infeld theory. The string is made of a D3-brane, wrapped around S^2 sphere. When looked from some distance, such an object does not appear to carry RR charge as a whole, but is rather like a RR dipole, and has energy per unit length proper to the fundamental string.

Such a configuration is only quasi-stable, since globally it is possible to lose energy by making the throat very wide: if it had radius R , the change in energy is mostly due to tension⁴ and goes like $\sim R^2 \cdot D - R^3$ and is arbitrarily negative. However, there is a potential energy barrier and one needs to construct the bouncing euclidean solution in order to address the problem in a complete way. In CM [6] it was attempted to approach the problem by dropping the contributions due to the electric field, in that case the lagrangian is Lorentz invariant with respect to r,t and it is possible to construct some approximation to the bouncing solution.

⁴The second term has the same origin as in [33]. The two branes act as a sort of capacitor to create a uniform bulk 3-form RR field to which the cylindrically wrapped brane couples. The only difference is dimensionality: in case of the 2-brane the potential goes as $-R^2$, and for the 3-brane it's $\sim -R^3$.

In this section we will compute exactly the energy of the string and sphaleron solution (the unstable static solution at the top of the potential barrier). This will allow to conclude that the tunneling rate in fact goes to infinity when the branes approach each other but still are at a finite distance $\sim l_s \sqrt{g_s}$.

2.4.1 The Two Static Configurations

We will review the construction of the relevant solution from CM [6]. Similar solutions were also considered by Gibbons in [7].

Consider the case when the worldbrane gauge field is purely electric and only one transverse coordinate X is excited. The worldbrane action reduces to

$$L = -\frac{1}{g_p} \int d^4x \sqrt{(1 - \vec{E}^2)(1 + (\vec{\nabla}X)^2) + (\vec{E}\vec{\nabla}X)^2 - \dot{X}^2}, \quad (2.36)$$

where $g_p = (2\pi)^3 g_s$, and g_s is the string coupling ($\alpha' = 1$).

The canonical momentum associated with \vec{A} is

$$g_p \vec{\Pi} = \frac{\vec{E}(1 + (\vec{\nabla}X)^2) - \vec{\nabla}X(\vec{E}\vec{\nabla}X)}{\sqrt{(1 - \vec{E}^2)(1 + (\vec{\nabla}X)^2) + (\vec{E}\vec{\nabla}X)^2 - \dot{X}^2}}. \quad (2.37)$$

The constraint equation is $\vec{\nabla} \cdot \vec{\Pi} = 0$. The Hamiltonian is

$$H = \frac{1}{g_p} \sqrt{(1 + (g_p \vec{\Pi})^2)(1 + (\vec{\nabla}X)^2) - (g_p \vec{\Pi} \times \vec{\nabla}X)^2}. \quad (2.38)$$

We are looking for the most general static, spherically symmetric solution. The equation for X , which follows from varying the energy, after setting $\dot{X} = 0$ is

$$\vec{\nabla} \frac{(1 - \vec{E}^2)\vec{\nabla}X + \vec{E}(\vec{E}\vec{\nabla}X)}{\sqrt{(1 - \vec{E}^2)(1 + (\vec{\nabla}X)^2) + (\vec{E}\vec{\nabla}X)^2}} = 0. \quad (2.39)$$

From (2.37) it follows that $g_p \vec{\Pi} = \frac{A \hat{r}}{r^2}$, and from (2.39) $\frac{\vec{\nabla}X}{\sqrt{1 - E^2 + \nabla X^2}} = \frac{B \hat{r}}{r^2}$. Here A and B are integration constants.

The expression (2.37) now simplifies to

$$g_p \vec{\Pi} = \frac{\vec{E}}{\sqrt{1 - E^2 + \nabla X^2}}.$$

The solution for the coordinate and electric field is

$$\vec{\nabla}X = \frac{B\hat{r}}{\sqrt{r^4 + A^2 - B^2}} \quad \vec{E} = \frac{A\hat{r}}{\sqrt{r^4 + A^2 - B^2}} . \quad (2.40)$$

One can view this solution as a way to minimally break supersymmetry, instead of $E = \nabla X$ we have $E = \frac{A}{B}\nabla X$. In principle, A should be quantized as electric charge in units of πg . We will be interested in $B > A$, in this case the resulting configuration will be the 3-brane and anti-brane joined by a smooth throat. To see this, one needs to explicitly exploit the geometry by finding X:

$$X(r) = B \int_r^\infty \frac{ds}{\sqrt{s^4 - r_0^4}} . \quad (2.41)$$

Here $r_0^4 = B^2 - A^2$. We have set $X(\infty) = 0$, e.g. far away the brane is flat and is at zero coordinate in the transverse direction. $X(r_0)$ is finite, but $X'(r_0)$ is infinite: the throat becomes vertical at that radius. This can be continued back out through r_0 to give the two branes. Branes possess orientation and continuing it through the throat we see that the new brane is of the opposite orientation: an antibrane.

The relations between A,B and r_0 , $X(r_0) = D/2$ can be solved to express r_0 and B in terms of D and A:

$$D/2 = c\sqrt{\frac{A^2}{r_0^2} + r_0^2} \quad \text{and} \quad B^2 = A^2 + r_0^4 , \quad \text{where} \quad c = \int_1^\infty \frac{dz}{\sqrt{z^4 - 1}} . \quad (2.42)$$

In the limit of large D the two possible radii at the throat are $r_0 \sim D/2c$, and $A \sim 2c/D$. A remark is in place here that the minimal separation for which a real root exists is $D_{min} = 2c\sqrt{2A}$.

Knowing the energy function

$$H = \sqrt{(1 + \nabla X^2)(1 + g\Pi^2)}$$

allows to compute the energies of the solutions exactly,

$$E_{tot} = \frac{1}{g_p} \int_{r_0}^{\infty} \sqrt{1 + \frac{A^2 + r_0^4}{r^4 - r_0^4}} \sqrt{1 + \frac{A^2}{r^4}} 4\pi r^2 dr \quad . \quad (2.43)$$

At this point the temptation to make the problem completely dimensionless becomes irresistible. Let me introduce the parameters $\mu = \frac{D}{2c\sqrt{A}}$, $r = z\sqrt{A}$. We are now measuring length in units of \sqrt{A} , energy in $A^{3/2}$, and also $r_0 = \xi\sqrt{A}$:

$$E = \frac{1}{g_p} \int_{\xi}^{\infty} \sqrt{1 + \frac{1 + \xi^4}{z^4 - \xi^4}} \sqrt{1 + \frac{1}{z^4}} 4\pi z^2 dz \quad . \quad (2.44)$$

Equations (2.42) can be written as $\mu^2 = \xi^2 + 1/\xi^2$. We define the two positive roots of this equation as ξ_1 and ξ_2 . One can see that $\xi_1 \cdot \xi_2 = 1$. The minimum separation is $\mu_{min} = \sqrt{2}$, at which point the two roots of the quadratic equation become degenerate: $\xi_1 = \xi_2 = 1$.

After some manipulations with the energy integral, and a variable change $y = \xi/z$, we get

$$\frac{g_p}{8\pi} E = \xi^3 \int_0^1 \frac{dy}{y^4 \sqrt{1-y^4}} + \frac{1}{\xi} \int_0^1 \frac{dy}{\sqrt{1-y^4}} \quad . \quad (2.45)$$

We have not dealt yet with the volume infinity which manifests itself in the fact that the first of these integrals is divergent at $y \rightarrow 0$. Regularize it by subtracting $1/y^4$ from the integrand : if one were to go back, it is exactly equivalent to computing the energy with respect to the configuration when the two branes are flat, parallel and not joined by any string. Denote the integrals in (2.45) as u and v,

$$\begin{aligned} u &= \int_0^1 \frac{dy}{y^4} \left(\frac{1}{\sqrt{1-y^4}} - 1 \right) - \int_1^{\infty} \frac{dy}{y^4} = -\frac{1}{3} + \sum_{n=1}^{\infty} \frac{1}{4n-3} \frac{(2n-1)!!}{n! 2^n} \\ u &= \frac{\sqrt{\pi} \Gamma(-3/4)}{4 \Gamma(-1/4)} = .43701... \\ v &= \int_0^1 \frac{dy}{\sqrt{1-y^4}} = \sqrt{\pi} \frac{\Gamma(5/4)}{\Gamma(3/4)} = 1.31103... \end{aligned}$$

The answers are not surprising, since both integrals are generalized B functions, and the second one is in fact the quarter period of the Jacoby elliptic functions. One can

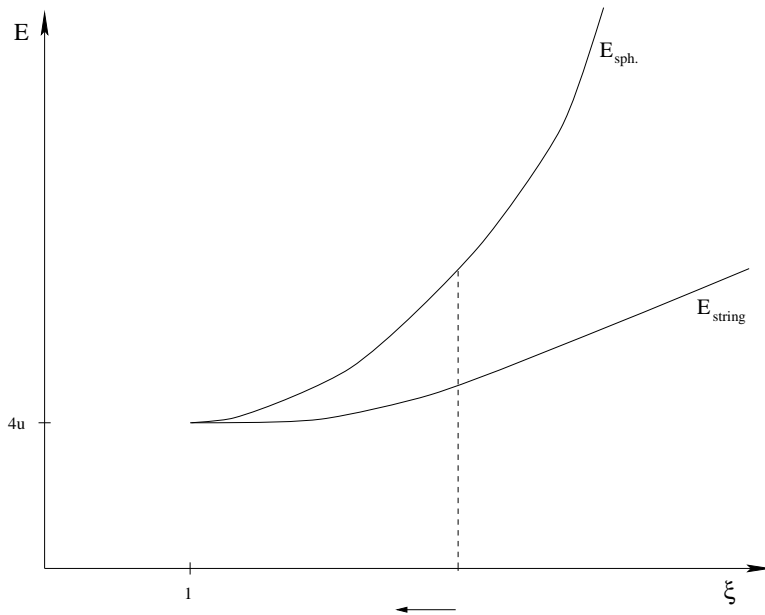

Figure 2.3: Energy vs. ξ . *Height of the barrier* = $E_{sph} - E_{string} \rightarrow 0$

also show, by using the functional properties of the Gamma function, that $3u = v$. Also, constant c from (2.42) is also related, in fact $c = v$. The energies of the string and the sphaleron become, respectively

$$E_{string} = u(\xi^{-3} + 3\xi) \quad E_{sph} = u(\xi^3 + 3\xi^{-1}) \quad .$$

Note, that we have now taken the larger of the two roots to be ξ , the other root being $1/\xi$. One can even write a relation between the energies of the string and sphaleron solutions $E_{string}(1/\xi) = E_{sph}(\xi)$. Even though this relation is formal, (each function is defined only for arguments larger than one) it might be of significance in the future. The energy of a long string after fully substituting the dimensionful units becomes

$$E_{string} = \frac{4\pi}{g_p} DA = \frac{4\pi}{8\pi^3 g} D\pi g = \frac{1}{2\pi} D \quad .$$

This reproduces the correct tension of the fundamental string. The slope of the energy function is zero at the minimum possible value of $\xi = 1$ (Fig 2.3).

One further interesting elaboration is possible. The energy surface in the parameter space of r_0 and D (or μ, ξ) apparently has a kink well known from catastrophe theory.

The point at which the kink first appears corresponds to $\mu^2 = 2$ and $\xi = 1$. For $\mu^2 < 2$ the energy is monotonous in ξ , and there is no static solutions, otherwise it has one minimum and one maximum, corresponding to the string and the sphaleron respectively.

2.4.2 Annihilation by Tunneling.

Let us recall that two branes, a 3-brane and an anti-brane, are going to gravitationally attract, even though weakly, causing them to move closer and to eventually annihilate. The tunneling through the potential barrier, the sphaleron being the unstable solution at the top, will be exponentially weak [6], but as the branes move closer μ and ξ become smaller. This makes the tunneling easier in a twofold way: by making the barrier both narrower (distance between ξ and $1/\xi$ becomes smaller), and shallower, with the energy at the top decreasing to become equal to the energy of the string. As $\xi \rightarrow 1$, the rate of tunneling rate increases indefinitely, and at $\xi = 1$ the metastable string state ceases to exist. This is an interesting example of physical continuity: before the state disappeared as we change the parameter (D or ξ), its physical width due to tunneling had to become infinite.

Unfortunately, even though these conclusions are self consistent, they may still be physically incomplete due to the fact that as branes approach to planckian distance new nonperturbative phenomena of annihilation may kick in. One possible way out of this difficulty is to crank up the string coupling, this leads into unknown territory too but our quasi-classical tunneling may indeed be the dominant mode of annihilation in that regime.

Chapter 3

Born-Infeld Action and AdS/CFT Correspondence

In this chapter we will construct solutions of the Born-Infeld action for a D5-brane in the background of a stack of N D3-branes. The original paper [32] is by C.G. Callan, A.Guijosa and myself, and I have freely used the text of that paper here. By building on some recent work of Imamura [56], we can find BPS-saturated solutions which presumably correspond to exact solutions of string theory. Using the general approach of [6, 7], these solutions use D5-branes wrapped in various ways to describe branes and strings attached to each other. The primary object we construct this way is a D5-brane joined to N D3-branes by a bundle of fundamental strings. Our solutions give a detailed description of the creation of these strings as the fivebrane is dragged across the threebranes.

As has been pointed out by various people [46, 47], in the context of the anti-de Sitter/conformal field theory (*AdS/CFT*) correspondence there are general reasons to expect N fundamental strings to join together on a D5-brane wrapped on a five-sphere in the throat region of the threebrane geometry (i.e. the *AdS* geometry). This is the string theory counterpart to the gauge theory $SU(N)$ baryon vertex, representing a bound state of N external quarks. The baryon vertex has been studied in [48], where the strings and the fivebrane are described in terms of separate Nambu-Goto actions.

That approach ignores the worldvolume gauge field on the fivebrane. Its inclusion leads to the Born-Infeld action, which allows a unified description of the fivebrane and the strings. When restricted to the *AdS* background, our solutions provide an explicit string theory representation of the baryon vertex. The Born-Infeld action for the worldbrane dynamics of the fivebrane in a threebrane background is an accessible and instructive way to go after the energetics of this problem.

In the second part of this Chapter we study baryon configurations in large N non-supersymmetric $SU(N)$ gauge theories, applying the *AdS/CFT* correspondence. This part is based on a paper [13] by C.G. Callan, A. Guijosa, O. Tafjord and myself. Using the D5-brane worldvolume theory in the near-horizon geometry of non-extremal D3-branes, we find embeddings which describe baryonic states in three-dimensional QCD. In particular, we construct solutions corresponding to a baryon made of N quarks, and study what happens when some fraction ν of the total number of quarks are bodily moved to a large spatial separation from the others. The individual clumps of quarks are represented by Born-Infeld string tubes obtained from a D5-brane whose spatial section has topology $\mathbf{R} \times \mathbf{S}^4$. They are connected by a confining color flux tube, described by a portion of the fivebrane that runs very close and parallel to the horizon. We find that this flux tube has a tension with a nontrivial ν -dependence (not previously obtained by other methods).

3.1 Baryons in AdS

In this chapter we will construct solutions of the Born-Infeld action for a D5-brane in the background of a stack of N D3-branes. By building on some recent work of Imamura [56], we can find BPS-saturated solutions which presumably correspond to exact solutions of string theory. Using the general approach of [6, 7], these solutions use D5-branes wrapped in various ways to describe branes and strings attached to each

other. The primary object we construct this way is a D5-brane joined to N D3-branes by a bundle of fundamental strings. Our solutions give a detailed description of the creation of these strings as the fivebrane is dragged across the threebranes.

As has been pointed out by various people [46, 47], in the context of the anti-de Sitter/conformal field theory (AdS/CFT) correspondence there are general reasons to expect N fundamental strings to join together on a D5-brane wrapped on a five-sphere in the throat region of the threebrane geometry (i.e. in the AdS geometry). This is the string theory counterpart to the gauge theory $SU(N)$ baryon vertex, representing a bound state of N external quarks. The baryon vertex has been studied in [48], where the strings and the fivebrane are described in terms of separate Nambu-Goto actions. That approach ignores the worldvolume gauge field on the fivebrane. Its inclusion leads to the Born-Infeld action, which allows a unified description of the fivebrane and the strings. When restricted to the AdS background, our solutions provide an explicit string theory representation of the baryon vertex. The Born-Infeld action for the worldbrane dynamics of the fivebrane in a threebrane background is an accessible and instructive way to go after the energetics of this problem.

3.1.1 The Setup

We set up the equations for the Born-Infeld D5-brane in the background geometry of a stack of N D3-branes. The metric in a standard coordinate system is

$$ds^2 = H(r)^{-1/2}(-dt^2 + dx_{\parallel}^2) + H(r)^{1/2}(dr^2 + r^2 d\Omega_5^2), \quad H(r) = a + R^4/r^4 .$$

We have chosen to express $H(r)$ in terms of an auxiliary constant a , in order to treat the asymptotically flat D3-brane ($a = 1$) and the $AdS_5 \times \mathbf{S}^5$ ($a = 0$) geometries in parallel. The worldvolume action is the Born-Infeld action calculated using the induced metric (including the worldvolume gauge field)

$$g_{\alpha\beta}^{ind} = g_{MN} \partial_{\alpha} X^M \partial_{\beta} X^N + \mathcal{F}_{\alpha\beta},$$

plus the WZW term induced by the five-form field strength; the latter is basically a source term for the worldvolume gauge field. The explicit action we will use is

$$S = -T_5 \int d^6\xi \sqrt{-\det(g^{ind})} + T_5 \int d^6\xi A_\alpha \partial_\beta X^{M_1} \wedge \dots \wedge \partial_\gamma X^{M_5} G_{M_1\dots M_5} ,$$

where T_5 is the D5-brane tension and the second term is the explicit WZW coupling of the worldvolume gauge field A to the background five-form field strength G . We use the target space time and \mathbf{S}^5 spherical coordinates as worldvolume coordinates for the fivebrane, $\xi_\alpha = (t, \theta_\alpha)$.

We pick a five-sphere surrounding a point on the threebrane stack and look for static solutions of the form $r(\theta)$ and $A_0(\theta)$ (with all other fields set to zero), where θ is the polar angle in spherical coordinates. Non-static solutions are of interest too, but we will not deal with them in this paper. On substituting explicit forms for the threebrane metric and the five-form field strength, the action (for static configurations) simplifies to

$$S = T_5 \Omega_4 \int dt d\theta \sin^4 \theta \{ -r^4 H(r) \sqrt{r^2 + (r')^2 - F_{0\theta}^2} + 4A_0 R^4 \}, \quad (3.1)$$

where $\Omega_4 = 8\pi^2/3$ denotes the volume of the unit four-sphere.

The gauge field equation of motion following from this action reads

$$(\sin \theta)^{-4} \partial_\theta \left[-\sin^4 \theta \frac{(ar^4 + R^4)E}{\sqrt{r^2 + r'^2 - E^2}} \right] = 4R^4 ,$$

where we have set $E = F_{0\theta}$ and the right-hand side is the source term coming from the WZW action. It is helpful to repackage this in terms of the displacement D (the variation of the action with respect to E):

$$D = \frac{\sin^4 \theta (ar^4 + R^4)E}{\sqrt{r^2 + r'^2 - E^2}} \Rightarrow \partial_\theta D(\theta) = -4R^4 \sin^4 \theta. \quad (3.2)$$

Obviously, we can integrate the equation for D to find it as an explicit function of θ . The result is

$$D(\theta) = R^4 \left[\frac{3}{2}(\nu\pi - \theta) + \frac{3}{2} \sin \theta \cos \theta + \sin^3 \theta \cos \theta \right], \quad (3.3)$$

where the integration constant has been written in terms of a parameter $0 \leq \nu \leq 1$, whose meaning will be elucidated below. Notice that the sign of the WZW term in (3.1) reflects the choice of a particular fivebrane orientation. Choosing the opposite orientation therefore reverses the sign of the source term in (3.2), and consequently the sign of D .

Since D , unlike E , is completely unaffected by the form of the function $r(\theta)$, it makes sense to express the action in terms of D and regard the result as a functional for $r(\theta)$. It is best to do this by a Legendre transformation, rewriting the original Lagrangian as

$$U = T_5 \Omega_4 \int d\theta \{ D \cdot E + \sin^4 \theta (ar^4 + R^4) \sqrt{r^2 + (r')^2 - E^2} \} .$$

Integrating the DE term by parts using $E = -\partial_\theta A_0$, one reproduces (with a sign switch) the original Lagrangian. Using (3.2) we can eliminate E in favor of D to get the desired functional of $r(\theta)$ alone:

$$U = T_5 \Omega_4 \int d\theta \sqrt{r^2 + (r')^2} \sqrt{D^2 + (ar^4 + R^4)^2 \sin^8 \theta} . \quad (3.4)$$

This functional is reasonably simple, but complicated by the fact that there is explicit dependence on θ . Hence there is no simple energy-conservation first integral that we can use to solve the equations (or at least analyse possible solutions). For future reference, we record the Euler-Lagrange equations that follow from (3.26):

$$\begin{aligned} \frac{d}{d\theta} \left(\frac{r'}{\sqrt{r^2 + r'^2}} \sqrt{D^2 + (ar^4 + R^4)^2 \sin^8 \theta} \right) &= \frac{r}{\sqrt{r^2 + r'^2}} \sqrt{D^2 + (ar^4 + R^4)^2 \sin^8 \theta} \\ &+ \frac{\sqrt{r^2 + r'^2}}{r} \frac{4ar^4(ar^4 + R^4) \sin^8 \theta}{\sqrt{D^2 + (ar^4 + R^4)^2 \sin^8 \theta}} . \end{aligned} \quad (3.5)$$

Supersymmetry considerations will allow us to go rather far in analysing the solutions of this formidable-looking equation.

When we discuss solutions in more detail, we will see that it will not be possible to wrap the fivebrane smoothly around a sphere. Even if $r(\theta) \sim r_0$ for most θ , we

will find that for $\theta \rightarrow \pi$ (or 0), r shoots off to infinity in a way that simulates a bundle of fundamental strings in the manner described in [6, 7]. Using (3.26) we can already verify that the energy of such a spike is consistent with its interpretation as a bundle of strings. Suppose that the spike sticks out at $\theta = \pi$; then D will take on some finite value $D(\pi)$ at $\theta = \pi$. As we go into the spike, r' will dominate r and the D term will dominate $\sin^8 \theta$. It is clear then that the spike has a ‘tension’ (i.e. an energy per unit radial coordinate distance) $T_5 \Omega_4 |D(\pi)|$. Using the known facts that $D(\pi) = 3\pi(\nu - 1)R^4/2$ and $T_5 \Omega_4 R^4 = 2NT_f/3\pi$, it follows that the ‘tension’ of the spike is that of n fundamental strings, nT_f , where $n = (1 - \nu)N$. This gives meaning to the parameter ν .

3.1.2 Supersymmetry Issues

We are interested in placing a D5-brane in a D3-brane background and finding a structure that looks like fundamental strings attached to the D3-branes. Insight into what is possible is often obtained by looking for brane orientations such that the various brane supersymmetry conditions are mutually compatible for some number of supersymmetries. In type IIB supergravity in ten-dimensional flat space, there are 32 supersymmetries generated by two 16-component constant Majorana-Weyl spinors η_L, η_R of like parity ($\Gamma_{11}\eta_{L,R} = \eta_{L,R}$). In the presence of branes of various kinds, the number of supersymmetries is reduced by the imposition of further conditions. Explicitly,

$$\begin{aligned}
\text{F - string} & : \quad \Gamma^{09}\eta_L = -\eta_L, \quad \Gamma^{09}\eta_R = +\eta_R, \\
\text{D3 - brane} & : \quad \Gamma^{0123}\eta_L = +\eta_R, \quad \Gamma^{0123}\eta_R = -\eta_L, \\
\text{D5 - brane} & : \quad \Gamma^{045678}\eta_L = +\eta_R, \quad \Gamma^{045678}\eta_R = +\eta_L,
\end{aligned} \tag{3.6}$$

where the particular gamma matrix products are determined by the embedding of the relevant branes into ten-dimensional space. For instance, the D3-brane condition refers

to a brane that spans the 123 coordinate directions. Conditions can be multiplied by an overall sign by changing brane orientation.¹ The existence of a BPS state containing more than one type of brane depends on the existence of simultaneous solutions of more than one of the above equations. The relevant point for our discussion is that the conditions precisely as written above, corresponding to mutually perpendicular D3-branes, D5-branes and F-strings, are compatible with eight supersymmetries ($\mathcal{N} = 2$ in usual parlance). The supersymmetry argument suggests that mutually orthogonal branes spanning a total of eight dimensions joined by a fundamental string running along the one remaining dimension (perpendicular to both branes) should in fact be a stable BPS state. An interesting aspect of our Born-Infeld worldvolume approach is that we will explicitly see how the fundamental strings are created and destroyed as the D-branes are moved past each other in the ninth direction (the Hanany-Witten effect [50, 51, 52]).

The above analysis has been carried out in flat space. To make contact with the *AdS/CFT* correspondence, one would want to consider N superposed D3-branes with N large, in which case the background geometry is not flat and the supersymmetry analysis given above is at least incomplete. Imamura [56] has analysed the supersymmetry conditions associated with a D5-brane stretched over some surface in the ‘throat’ of the D3-brane (where the geometry is $AdS_5 \times S^5$ and there is a flux of the RR five-form field strength through the S^5). There are several new features here: first, the unbroken supersymmetries of type IIB supergravity in this particular background are 32 position-dependent spinors (as opposed to constant spinors in flat space); second, because of the RR five-form field strength, there is a worldbrane gauge field induced on the worldvolume of the D5-brane; third, the condition that a particular element of the D5-brane worldvolume preserve some supersymmetry involves the local orientation

¹Notice, however, that to maintain a supersymmetric configuration one must simultaneously reverse the orientation of two of the three objects.

of the brane, the value of the induced worldvolume gauge field and the local value of the supergravity supersymmetry spinors. Since the D5-brane is embedded in some nontrivial way in the geometry, the supersymmetry condition is in principle different at each point on the worldvolume and it is far from obvious that it can be satisfied everywhere.

However, Imamura [56] was able to show that these conditions boil down, at least in the AdS_5 ($a = 0$) background, to a first-order equation for the embedding of the D5-brane into the space transverse to the D3-brane stack. In our language, his BPS condition can be written

$$\frac{r'}{r} = \frac{R^4 \sin^5 \theta + D(\theta) \cos \theta}{R^4 \sin^4 \theta \cos \theta - D(\theta) \sin \theta} , \quad (3.7)$$

where $r = r(\theta)$ is the D5-brane embedding in the transverse space and $D(\theta)$ is the ‘displacement’ field describing how the worldvolume gauge field varies from point to point. It is easy to show that any function $r(\theta)$ that satisfies this condition automatically satisfies the Euler-Lagrange equation (3.5) with $a = 0$; in that sense it is a first integral of the usual second-order equations. Note that, as mentioned above, the structure of the action is such that there is no trivial energy first integral. The BPS condition (3.7) can be integrated analytically to obtain a two-parameter family of curves that describe BPS embeddings of a D5-brane into the $AdS_5 \times S^5$ geometry. These solutions will be discussed in the next section.

We are also interested in exploring the analogous solutions in the full asymptotically flat D3-brane background ($a = 1$). In this background the interpretation and energetics of solutions should be quite straightforward. What is less obvious is how to find BPS solutions. To follow Imamura’s approach, one would first find the supersymmetry spinors in the D3-brane background, use them to construct local supersymmetry conditions for an embedded D5-brane and from this find the condition on the embedding for there to be a global worldvolume supersymmetry. This is no doubt perfectly

feasible but we have not had the patience to try it. Instead, we have simply guessed a generalization of the $AdS_5 \times \mathbf{S}^5$ BPS condition that automatically provides a solution of the Euler-Lagrange equations in the full D3-brane background. The generalized BPS condition is obtained by making the (very plausible) replacement $R^4 \rightarrow R^4 + r^4$ in (3.7),

$$\frac{r'}{r} = \frac{(R^4 + r^4) \sin^5 \theta + D(\theta) \cos \theta}{(R^4 + r^4) \sin^4 \theta \cos \theta - D(\theta) \sin \theta} . \quad (3.8)$$

It is easy to verify, using only (3.2), that this equation implies the full Euler-Lagrange equation (3.5) with $a = 1$, so it is certainly a first integral. Given its origin, it is almost certainly the BPS condition as well. It is rather surprising that things work so smoothly, and we take this as another evidence of the special nature of the D3-brane background. The first-order equation (3.8) must be integrated numerically (as far as we know) and yields a two-parameter family of solutions whose structure is quite non-trivial. Exploration of these and the AdS solutions will be the subject of the rest of the paper.

Before closing this section we note that in either background one can obtain an ‘alternative’ BPS condition by reversing the signs in front of D in equations (3.7) or (3.8). The resulting condition would guarantee the preservation of a different set of supersymmetries, albeit just as many. In order to still have a first integral of the Euler-Lagrange equation (3.5), D must satisfy (3.2) with the opposite sign for the source term. Such oppositely oriented fivebrane configurations will actually have the same embedding $r(\theta)$.

3.1.3 AdS background: Born-Infeld Baryons

We start with a discussion of the solutions of the AdS BPS equation (3.7) for the supersymmetric embedding of a fivebrane in the $AdS_5 \times \mathbf{S}^5$ geometry, with topology

$\mathbf{S}^4 \times \mathbf{R}$. Fortunately, the BPS equation has the following simple analytic solution:²

$$r(\theta) = \frac{A}{\sin \theta} \left[\frac{\eta(\theta)}{\pi(1-\nu)} \right]^{1/3}, \quad \eta(\theta) = \theta - \pi\nu - \sin \theta \cos \theta, \quad (3.9)$$

where the scale factor A is arbitrary, and ν is the integration constant in (3.25). The freedom of changing A is a direct consequence of the scale invariance of the AdS background: if $r(\theta)$ is a solution of (3.7), then so is $\lambda r(\theta)$ for any λ . Note that $\eta > 0$ (so that the solution makes sense) only for $\theta_{cr} < \theta < \pi$, where θ_{cr} is defined by

$$\pi\nu = \theta_{cr} - \sin \theta_{cr} \cos \theta_{cr}. \quad (3.10)$$

This critical angle increases monotonically from zero to π as ν increases from zero to one. Furthermore, when $\theta_{cr} > 0$, $r(\theta_{cr}) = 0$, a fact whose consequences will be explored below.

The fact that (if $\nu \neq 1$) the solution diverges as $r \sim A/(\pi - \theta)$ when $\theta \rightarrow \pi$ means that a polar plot of $r(\theta)$ has, asymptotically, the shape of a ‘tube’ of radius A . (This way of describing the surface is a bit misleading as to the intrinsic geometry, but helps in visualization.) This tube is to be interpreted as a bundle of fundamental strings running off to infinity in the space transverse to the D3-branes. As explained in subsection 3.1.1, the asymptotic ‘tension’ of the tube equals that of $(1 - \nu)N$ fundamental strings. For the classical solutions ν is a continuous parameter, but at the quantum level ν should obey the quantization rule $\nu = n/N$.

In Figure. 3.1 we have plotted (3.9) for some representative values of ν . Consider first the special case $\nu = 0$, which yields a tube with the maximal asymptotic tension NT_f and corresponds to the classic ‘baryon’ vertex. In this case the solution starts at a finite radius $r(0) = (2/3\pi)^{1/3}A$, with $r'(0) = 0$, and then $r(\theta)$ increases monotonically with θ . The initial radius $r(0)$ represents another way of setting the overall scale of this scale-invariant solution. The fact that the fivebrane surface stays away from the

²We thank Ø. Tafjord for help in finding this solution.

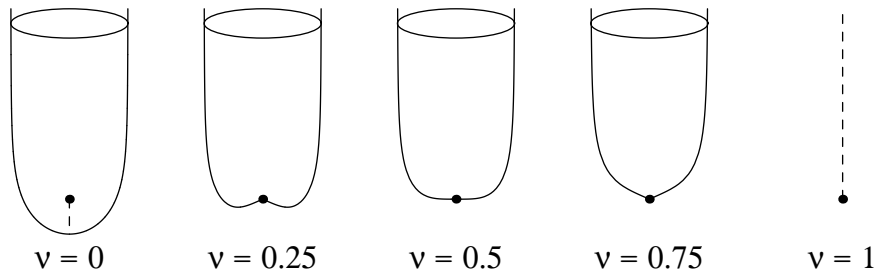

Figure 3.1: Polar plots of $r(\theta)$ for AdS ‘tube’ solutions corresponding to $(1 - \nu)N$ strings (with $\theta = \pi$ at the top of the plots). A cross-section of each ‘tube’ is an S^4 .

horizon at $r = 0$ suggests that it is well-decoupled from degrees of freedom living on the the threebranes. As far as the BPS equation is concerned, it seems to make sense to consider the $\nu > 0$ solutions as well. They have instructive features, although we will eventually conclude that they are on a less sound footing than their $\nu = 0$ cousins. For large r , the solution asymptotes to the familiar tube with a tension corresponding to $(1 - \nu)N < N$ strings: it corresponds to a general multi-quark state of a $U(N)$ gauge theory. As mentioned above, for $\nu > 0$, the surface intersects $r = 0$ at an angle $\theta_{cr} > 0$ defined by (3.31), leading to the cusp-like configurations displayed in Fig. 3.1. Note that, because the $r \rightarrow 0$ cusp has a finite opening angle, the fivebrane does not capture all of the five-form flux: this is closely related to the fact that the asymptotic tension is $(1 - \nu)N$ and not N .

As $\nu \rightarrow 0$, the opening angle $\theta_{cr} \rightarrow 0$. The approach to the $\nu = 0$ solution, which does not contact $r = 0$, is achieved, as shown in Fig. 3.1, via a ‘tensionless string’ connecting the minimum radius of the $\nu = 0$ solution to $r = 0$ (indicated as a dotted line in the figure). At the other extreme, $\nu \rightarrow 1$, one has $\theta_{cr} \rightarrow \pi$, and the solution collapses to a similar ‘phantom string’, this time running from $r = 0$ to infinity.

One can compare the total energy of these configurations to that of $(1 - \nu)N$ fundamental strings (this was done in [56] for the case of $\nu = 0$). Using the solution

(3.9) in expression (3.26), the energy of the fivebrane up to an angular cutoff θ_{max} can be put in the form

$$U(\theta_{max}) = NT_f \frac{A}{\pi} \int_{\theta_{cr}}^{\theta_{max}} d\theta \left[\frac{\eta(\theta)}{\pi(1-\nu)} \right]^{1/3} \left\{ \frac{\eta(\theta)}{\sin^2 \theta} - \frac{4}{3} \sin \theta \cos \theta + \frac{4 \sin^4 \theta}{9\eta(\theta)} \right\}. \quad (3.11)$$

The fundamental string energy, on the other hand, for strings extending from the origin to a radial cutoff $r_{max} = r(\theta_{max})$, is simply $E_{str}(\theta_{max}) = (1-\nu)NT_f r(\theta_{max})$. It is easy to check numerically that $E_{str}(\theta_{max}) - U(\theta_{max}) \rightarrow 0$ as $\theta_{max} \rightarrow \pi$ ($r_{max} \rightarrow \infty$). The Born-Infeld fivebrane ‘tubes’ can be therefore regarded as threshold bound states of $(1-\nu)N$ fundamental strings. We emphasize that this holds for any value of the scale parameter A : as $\theta_{max} \rightarrow \pi$, the energy $U(\theta_{max})$ becomes independent of A . The parameter A is therefore a modulus in the space of equal-energy solutions.

A complication for the interpretation of these solutions is that, in general (specifically, when $\nu \neq 0, 1/2, 1$), the total five-form flux captured by the fivebrane differs from the number of fundamental strings, $(1-\nu)N$, indicated by the asymptotic tension or total energy. The fundamental string charge is the source of the displacement field D , and we can rearrange (3.2) to show that a fivebrane that runs from $\theta = \theta_{cr}$ to $\theta = \pi$ intercepts a total five-form flux

$$Q_{flux} = -\frac{2N}{3\pi R^4} [D(\pi) - D(\theta_{cr})] = (1-\nu)N + \frac{2N}{3\pi} \sin^3 \theta_{cr} \cos \theta_{cr}.$$

From the value of the tension, we would have expected a total charge $Q_{tot} = (1-\nu)N$ on the D5-brane. The difference,³

$$Q_{missing} = -\frac{2N}{3\pi R^4} \sin^3 \theta_{cr} \cos \theta_{cr}, \quad (3.12)$$

is nonzero for $\nu \neq 0, 1/2, 1$ and presumably must be accounted for by a point charge at $r = 0$. Since $r = 0$ is where the fivebrane makes contact with the threebranes, this reminds us that, in order to be fully consistent, we should take into account

³It should be clear that Q_{flux} , Q_{tot} , and $Q_{missing}$ all change sign if we reverse the fivebrane orientation.

the possibility of exciting the threebrane worldvolume $U(N)$ gauge fields when we attach fundamental strings to the D3-branes (as in [6, 7]). The case of N strings ($\nu = 0$) is special since they can be in a $U(N)$ singlet which will decouple from the D3-brane worldvolume gauge theory. When $\nu \neq 0$, we are talking about a collection of strings that cannot be $U(N)$ neutral and must excite the D3 gauge fields, which will in turn react back on the metric. Since we have not allowed for this possibility in our construction, the detailed features of our solutions with $Q_{missing} \neq 0$ have to be taken with a certain grain of salt. The case $\nu = 1/2$ is peculiar: it corresponds to $N/2$ strings and so cannot form a $U(N)$ singlet, yet has $Q_{missing} = 0$. We are not sure that it really has the same status as the true singlet $\nu = 0$ solution.

In light of the *AdS/CFT* correspondence [43, 44, 45], the above results are expected to have a gauge theory interpretation. As discussed by several people [46, 47], a baryon (a bound state of N external quarks) in the $SU(N)$ $\mathcal{N} = 4$ supersymmetric Yang-Mills (SYM) theory corresponds, in the dual *AdS* description, to N fundamental strings which join together on a D5-brane wrapped on an \mathbf{S}^5 at some radius. The Born-Infeld $\nu = 0$ fivebrane configuration described above provides a detailed representation of such a baryon. In particular, the absence of binding energy is as expected for a BPS threshold bound state in the $\mathcal{N} = 4$ theory. Our other solutions with $\nu = n/N$ ($0 < n < N$) are also BPS and correspond to threshold bound states of $N - n$ quarks. The existence of color non-neutral states with finite (renormalized) energy is perfectly reasonable in a non-confining theory. To start learning something interesting about these states, we would have to go beyond mere energetics and ask some dynamical questions. To be absolutely clear, we emphasize that in every case discussed here the quarks in the gauge theory are all at the same spatial location.

The solutions that we have discussed so far are naturally restricted to the range of angles $\theta_{cr} \leq \theta \leq \pi$ where $\eta(\theta) > 0$. We will call them ‘upper tubes’. A simple modification of (3.9) is valid for the complementary angular range $0 \leq \theta \leq \theta_{cr}$ where

$\eta(\theta) < 0$:

$$\tilde{r}(\theta) = \frac{\tilde{A}}{\sin \theta} \left[\frac{-\eta(\theta)}{\pi \nu} \right]^{1/3}. \quad (3.13)$$

This expression is singular at $\theta = 0$ (where $\tilde{r}(\theta) \sim \tilde{A}/\theta$) and meets the origin at $\theta = \theta_{cr}$. It represents a downward-pointing tube of ‘radius’ \tilde{A} whose shape and tension are the same as for an upward-pointing tube with parameter $1 - \nu$. In other words, $\tilde{r}(\theta; \nu) = r(\pi - \theta; 1 - \nu)$. This ‘lower tube’ solution intercepts a total flux $Q_{flux} = -\nu N + 2N \sin^3 \theta_{cr} \cos \theta_{cr} / 3\pi$. From the tension of this configuration, we would have expected a total charge $Q_{tot} = -\nu N$, so there is a charge $Q_{missing}$ localized at the origin which is again given by (3.12). If the ‘upper tube’ solution corresponds to some number of quarks, the ‘lower tube’ solution corresponds to some number of antiquarks.

Finally we want to speculate about constructing new solutions by combining the $\nu \neq 0$ solutions we have been discussing. Specifically, we are interested in obtaining configurations for which the peculiar charge at the origin cancels. Inspection of (3.12) shows that this can be achieved by merging two tubes whose opening angles are complementary. Using equation (3.31) this means that if one of the tubes has parameter ν , the other one must have parameter $1 - \nu$. Taking into account the possibility of using ‘upper’ or ‘lower’ solutions, one is thus led to two types of configurations, illustrated in Fig. 3.2.

The combination of two upper tubes with parameters ν and $1 - \nu$ yields a baryon-like configuration corresponding to a total of N quarks. This system differs from the $\nu = 0$ baryon of Fig. 3.1 in that the ‘strings’ have been separated into two distinct coaxial tubes. It is interesting to note that this combined structure can be obtained as a single solution of (3.7), with a unique value of ν , by formally continuing $r(\theta)$ in (3.9) beyond $\theta = \theta_{cr}$ (where $r = 0$) to negative values of r . The continued solution, depicted in Fig. 3.2, can be interpreted as a single surface which intersects itself at the origin. In this interpretation the parameter ν is an additional modulus of the baryon,

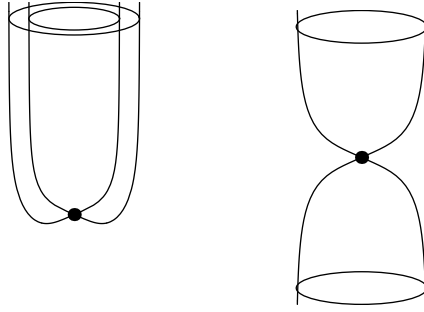

Figure 3.2: Upper/upper and upper/lower tube combinations. These configurations have vanishing charge at the origin (see text).

controlling how many strings (out of the total of N) ‘lie’ in each tube.

If instead one puts together an upper ν and a lower $1 - \nu$ solution, the result represents $1 - \nu$ strings which extend from $r = \infty, \theta = 0$ to $r = \infty, \theta = \pi$, and run through the origin. In the gauge theory language this describes a state with $1 - \nu$ quarks and the same number of antiquarks. (This is still BPS, because the quarks and antiquarks have opposite $SU(4)$ quantum numbers.) The total charge of the state vanishes.

Judging from the cancellation of the charge at the origin, these combined solutions would appear to have the same status as the baryon. On the other hand, it is unclear to what extent these superposed tubes can be regarded as a single object, given that they are ‘connected’ only at the infinitely distant point $r = 0$. It would be interesting to see whether fluctuations propagating inward along one tube can ‘tunnel’ through the point at $r = 0$ to propagate outward along the second tube.

3.2 Hanany-Witten effect in the full D3-brane metric background

So far, we have looked at the static solutions of D5-branes in the $AdS_5 \times \mathbf{S}^5$ geometry of the ‘throat’ region of the exterior geometry of a large number of D3-branes. As we now know, this limit gives us a supergravity description of $\mathcal{N} = 4$ SYM theory. We can also shed light on some old string theory questions by studying the same types of configurations in the full asymptotically flat geometry of multiple D3-branes.

To examine the character of the solutions in the asymptotically flat D3-brane background, it is convenient to parametrize the solution by $z = z(\rho)$, where $\rho = r \sin \theta$, and $z = -r \cos \theta$. In these variables, adapted to flat space, the BPS condition (3.8) reads

$$z'(\rho) = \frac{-D(\arctan(-\rho/z))}{\rho^4 \left(1 + \frac{R^4}{(\rho^2 + z^2)^2}\right)}. \quad (3.14)$$

Solutions to this equation describe D5-brane configurations which asymptote to a flat plane as $\rho \rightarrow \infty$ (equivalently, $\theta \rightarrow \pi/2$). The leading asymptotic behavior following from (3.14) is

$$z(\rho) = z_{max} + \frac{D(\pi/2)}{3\rho^3} + \mathcal{O}\left(\frac{R^4}{\rho^4}\right), \quad (3.15)$$

where z_{max} denotes the transverse position of the flat brane. We will be interested in studying how the solution changes as we vary z_{max} .

Figures 3.3 and 3.4 show the configurations obtained by integrating (3.14) numerically for $\nu = 0$ and $\nu = 1/2$ and for a few representative values of z_{max} . The stack of N D3-branes is at the origin, and extends along directions perpendicular to the figure. For any value of z_{max} , the D5-brane captures the same fraction of the total five-form flux, which (in conjunction with a possible point charge at the origin, as discussed in the previous subsection) effectively endows the D5-brane with a total of $(1/2 - \nu)N$ units of charge. Note the shift of $N/2$ units of charge, compared with the analogous situation in AdS space: this happens because the asymptotic region of the brane is

now at $\theta = \pi/2$ rather than $\theta = \pi$. This will have interesting consequences.

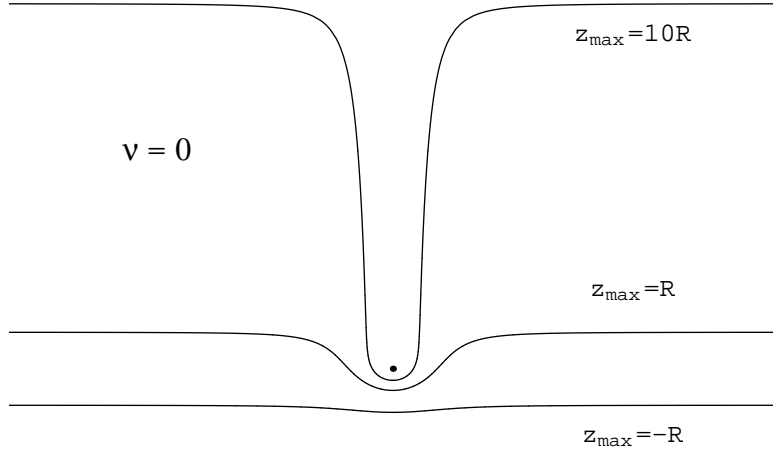

Figure 3.3: Solutions describing the creation of N fundamental strings as a D5-brane is dragged upward, across a stack of D3-branes. The number of strings connecting the two types of branes changes from 0 to N .

Consider first the situation for $\nu = 0$, described graphically in Figure 3.3. As $z_{max} \rightarrow -\infty$, the charge density vanishes, and the D5-brane of course becomes flat. As one approaches the stack of threebranes from below ($z_{max} \rightarrow 0_-$), the charge becomes more and more localized near the center of the fivebrane, and the configuration becomes slightly deformed, bending away from the origin. As z_{max} increases, the D5-brane remains ‘hung-up’ on the D3-brane stack at $r = 0$ and a tube of topology $\mathbf{S}^4 \times \mathbf{R}$ gets drawn out. The total charge of the tube itself approaches N as it gets longer and longer and it becomes indistinguishable from a bundle of N fundamental strings. Curiously, when the bundle eventually connects to the flat D5-brane, a region of negative five-form flux is encountered and the total charge intercepted by the fivebrane drops to $N/2$ (for any z_{max}). Altogether, then, this family of solutions provides a very concrete picture of the creation of fundamental strings as a fivebrane is dragged over a stack of threebranes, the Hanany-Witten effect [50, 51, 52].

For $\nu > 0$ the story is modified in exactly the same way as in the previous subsection.

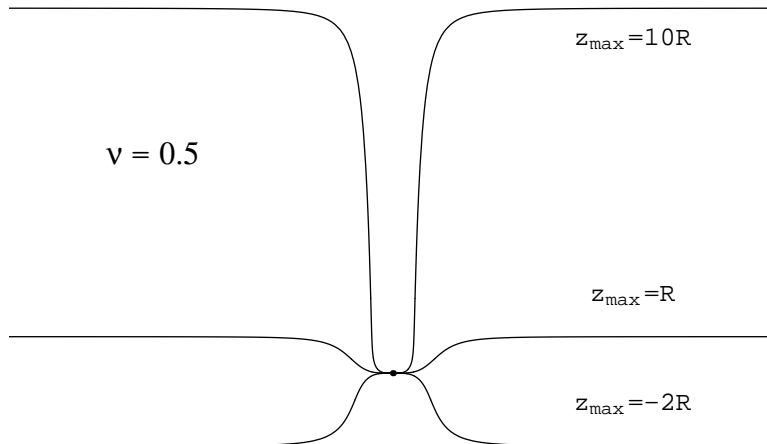

Figure 3.4: Solutions describing the creation of N fundamental strings as a D5-brane is dragged across a stack of D3-branes. The number of strings connecting the two types of branes changes from $-N/2$ to $+N/2$ (the signs indicate whether the strings originate or terminate on the fivebrane).

For either sign of z_{max} , the fivebrane now reaches the origin, $r = 0$, at an angle $\theta = \theta_{min}$ given in terms of ν by equation (3.31). As $z_{max} \rightarrow -\infty$ the solution describes now a fivebrane connected by νN strings to the stack of threebranes. For definiteness, assume the choice of sign for D (i.e., the orientation of the fivebrane) is such that the strings emanate from the D5-brane and terminate on the D3-branes. Upon moving past $z_{max} = 0$, N strings directed towards the fivebrane are created, and as $z_{max} \rightarrow \infty$ $(1 - \nu)N$ strings directed away from the threebranes extend between the two types of branes. The case $\nu = 1/2$ is portrayed in Figure 3.4.

It is instructive to compare the solution described above to the description of fundamental strings attached to a fivebrane as a Coulomb solution of the fivebrane Born-Infeld theory [6, 7]. In the latter case the parent brane is embedded in flat space and the worldvolume gauge field is simply that of a point charge. For n units of charge, the spike configuration that protrudes from the brane at the location of the charge is

of the form

$$z(\rho) = z_{max} - \frac{nc_5}{\rho^3}, \quad (3.16)$$

where $c_5 = 2\pi^2 g_s (\alpha')^2$ is the quantum of charge. Writing this in terms of the threebrane throat radius $R = (4\pi N g_s (\alpha')^2)^{1/4}$, one can readily verify that the asymptotic form (3.15) agrees with the solution (3.16) for $n = (1/2 - \nu)N$ strings. This is precisely as one would expect from the above discussion, for the entire fivebrane captures precisely a fraction $(1/2 - \nu)$ of the total five-form flux. By the same token, it is clear that the present solution is of a more complex nature than that of [6, 7]. The configuration discussed here corresponds roughly to a solution which is locally of the type (3.16), but where the charge n varies as one changes position on the fivebrane.

One of the more confusing features of the Hanany-Witten effect is its energetics: does the created string exert a force and, if so, how is that consistent with the BPS property? We can shed some light on this by computing the energy of our configurations. In terms of the $z(\rho)$ parametrization, and using the fact that $T_5 \Omega_4 R^4 = 2NT_f/3\pi$, equation (3.26) becomes

$$U = NT_f \frac{2}{3\pi} \int d\rho \sqrt{1 + (\partial_\rho z)^2} \sqrt{D^2 + \rho^8 \left[1 + \frac{R^4}{(\rho^2 + z^2)^2} \right]^2}. \quad (3.17)$$

We can use the BPS condition (3.14) to express the energy integrand for our solutions solely as a function of z and ρ ,

$$U = NT_f \frac{2}{3\pi} \int d\rho \left\{ \frac{D^2}{\rho^4 \left[1 + \frac{R^4}{(\rho^2 + z^2)^2} \right]} + \rho^4 \left[1 + \frac{R^4}{(\rho^2 + z^2)^2} \right] \right\}. \quad (3.18)$$

Now, the energy of the infinite D5-brane is evidently divergent, so (3.18) must be regularized. If we do so by placing a cutoff ρ_c on ρ , the leading and subleading contributions to (3.18) are clearly quintic and linear in ρ_c , respectively. The offending terms, however, are independent of z_{max} , so we choose to simply drop them (thereby removing an infinite constant from U). Altogether, then, we subtract $\rho^4 + R^4$ from the

integrand of (3.18) to obtain the expression

$$\hat{U}(z_{max}, \rho_c) = NT_f \frac{2}{3\pi} \int_0^{\rho_c} d\rho \left\{ \frac{D^2}{\rho^4 \left[1 + \frac{R^4}{(\rho^2 + z^2)^2} \right]} - \frac{2\rho^2 z^2 + z^4}{(\rho^2 + z^2)^2} \right\}, \quad (3.19)$$

which is finite as the cutoff is removed. Using the numerical solutions, one finds that in fact $\hat{U} \rightarrow (1/2 - \nu)NT_f z_{max}$ for all z_{max} as $\rho_c \rightarrow \infty$.

Since the difference between U and \hat{U} is a constant, it readily follows that there is a net constant force on the fivebrane, independent of z_{max} :

$$\frac{\partial}{\partial z_{max}} U(z_{max}, \rho_c) \rightarrow \left(\frac{1}{2} - \nu \right) NT_f \quad \text{as } \rho_c \rightarrow \infty. \quad (3.20)$$

The total force equals the tension of $(1/2 - \nu)N$ fundamental strings as a consequence of the fact that the full configuration carries a total of $(1/2 - \nu)N$ units of charge. It might seem surprising at first that there is a force on the fivebrane even for $\nu = 0$ and $z_{max} < 0$ (i.e., before the D5-brane crosses the D3-brane stack and a tube of strings is created), but one must keep in mind that even then there is a charge on the brane, and consequently a position-dependent energy. After the fivebrane is moved past the threebranes, to $z_{max} > 0$, a bundle of fundamental strings is created, and this bundle pulls down on the fivebrane with a force which tends to NT_f as $z_{max} \rightarrow \infty$. The net force on the brane is still $(1/2 - \nu)NT_f$, however, because the outer portion of the brane now carries negative charge, as a consequence of which there is an additional, upward force on the brane. Our approach thus makes it absolutely clear that, contrary to the naive expectation, there is no discontinuity in the force as the branes cross. One is able to find static solutions despite the presence of a constant force because the D5-brane is infinitely massive, and therefore will not move. If desired, this constant force can be cancelled by placing $(1 - 2\nu)N$ additional D3-branes at $z = -\infty$.

An alternative way to reach the same conclusions is to compute the force by cutting off (3.17) at ρ_c and differentiating with respect to z_{max} under the integral (regarding $z = z(\rho; z_{max})$). After an integration by parts and an application of the Euler-Lagrange

equation, one is left only with a boundary term, which yields the analytic expression

$$\frac{\partial U}{\partial z_{max}}(z_{max}, \rho_c) = NT_f \frac{2}{3\pi} \left\{ \frac{\partial_\rho z}{\sqrt{1 + (\partial_\rho z)^2}} \sqrt{D^2 + \rho^8 \left[1 + \frac{R^4}{(\rho^2 + z^2)^2} \right]^2} \frac{\partial z}{\partial z_{max}} \right\} \Big|_{\rho_c}. \quad (3.21)$$

Using (3.21) and (3.15) one can again conclude that the force on the fivebrane approaches $(1/2 - \nu)NT_f$ as $\rho_c \rightarrow \infty$ at a fixed z_{max} . Furthermore, using the numerical solution in conjunction with (3.21), one can compute the force on the $\rho < \rho_c$ portion of the brane, for any value of ρ_c . For any fixed ρ_c , it is easy to see that the force tends to $(1 - \nu)NT_f$ (νNT_f) as $z_{max} \rightarrow \infty$ ($z_{max} \rightarrow -\infty$). Taking the limit this way picks out the stress on the string tube part of the configuration and yields the expected tension of $(1 - \nu)N$ (νN) fundamental strings. Nonetheless, the total asymptotic stress on the D5-brane is smaller by $N/2$ fundamental string units, due to the extra five-form flux intercepted by the flat part of the D5-brane.

Notice that for $\nu = 1/2$ the net force on the D5-brane vanishes. This is because in that case the total charge on the brane is zero. As a result, the ρ^{-3} term in (3.15) has a vanishing coefficient. This configuration has $z(\rho = 0) = z'(\rho = 0) = 0$, $\theta_{min} = \pi/2$, and $D(\theta_{min}) = 0$. It is only for this and the $\nu = 0$ and $\nu = 1$ cases that the point charge at the origin vanishes. This solution (depicted in Fig. 3.4) describes a bundle of $N/2$ strings which flip their orientation as the fivebrane to which they are attached is moved above or below the threebrane stack. The number of attached strings still changes by N , from $-N/2$ to $+N/2$, as the D5-brane is pulled through the stack. This configuration is thus a realization of the ‘half-string’ ground-state of the system described in [52]. For reasons explained in that paper, and confirmed by our energy analysis, this is the only solution which is in a state of neutral equilibrium.

Just as in the previous subsection, one could imagine combining solutions to obtain configurations in which the charge at the origin vanishes. We will focus attention here on the possibility of superposing two solutions with parameters ν , $z_{max} > 0$ and

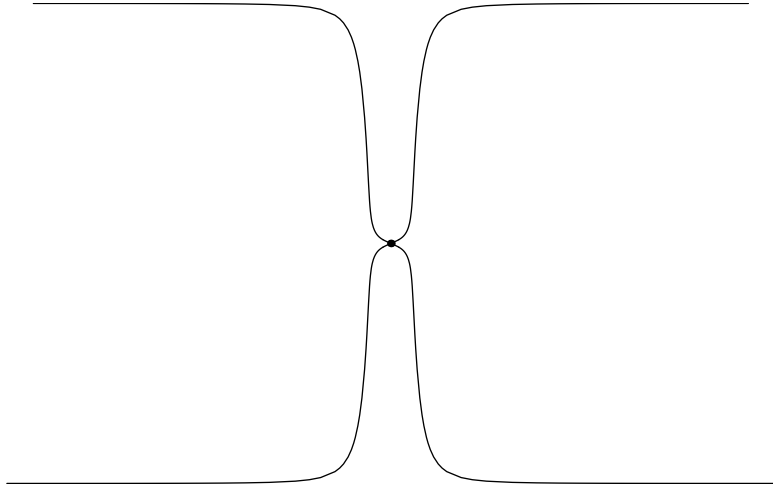

Figure 3.5: Solution describing a system of two parallel D5-branes connected by $(1 - \nu)N$ fundamental strings which run through the D3-branes at $r = 0$. A ‘point W-boson charge’ lies at the origin.

$1 - \nu, -z_{max}$, respectively. The complete structure obtained this way is illustrated in Figure d5d5strings, and corresponds to a configuration in which two infinite parallel D5-branes with the same orientation, located at $\pm z_{max}$, are connected by $(1 - \nu)N$ fundamental strings running through the N D3-branes at the origin. Something interesting has happened here: we have constructed an excitation of a system of two parallel fivebranes, something which should more properly be described by the non-abelian $SU(2)$ Born-Infeld action. We have achieved this effect (perhaps illegitimately!) by gluing together two $U(1)$ solutions at the singularity provided by the D3-branes. The logic of this construction is similar in spirit to a previous attempt to construct Prasad-Sommerfield monopole configurations from Born-Infeld dynamics [57]. Following that interpretation, the point charges of the component solutions at the origin should be understood not to cancel, but to combine instead into a ‘point W-boson charge’ which interpolates, at no cost in energy, between the two $U(1)$ s of the overall broken $U(2)$ symmetry.

The threebrane background geometry evidently plays a role in facilitating the construction described above. Nevertheless, since the ‘strings’ in the solution are interpreted as merely passing through the D3-branes, it is natural to conjecture that there exist neighboring static fivebrane configurations in which the strings miss the origin. Deforming the system in this manner it would be possible to move the connecting strings arbitrarily far away from the threebranes, thereby producing the analogous flat space configuration. It would be very interesting to pursue this issue further.

3.3 The Baryon in Three Dimensions

The Born-Infeld action plus an appropriate Wess-Zumino term defines a worldvolume theory for D-branes which has proved to be a powerful way to describe these objects and their excitations. In the context of Maldacena’s correspondence between supergravity in anti-de Sitter (*AdS*) space and certain gauge theories [43, 44, 45], there are gauge theory questions which can be answered by the study of branes extended in curved space. In particular, it was shown in a general way that the large- N_c dynamics of baryons can be related to the behavior of D5-branes extended in *AdS* space [46, 47]. Concrete realizations of this possibility in the context of the non-confining $\mathcal{N} = 4$ supersymmetric gauge theory have been worked out in [12, 31] using the Born-Infeld approach for constructing strings out of D-branes [6, 7]. In this paper, we will look at how these constructions work in the more complicated spacetimes that correspond to various confining gauge theories. We will examine confining forces by looking at what happens to baryons when they are pulled apart into their quark constituents. This will be compared to (and yields somewhat more information than) the study of confining forces via simple strings that ‘hang’ into the *AdS* geometry from a boundary Wilson loop [30, 34, 49, 47].

In this Section, we extend our previous work [12] on D5-branes in extremal back-

ground in three ways. First, we will study non-extremal supergravity backgrounds, corresponding to gauge theories dimensionally reduced in a way that breaks supersymmetry. Second, we allow the brane configurations to have extension in the spacetime coordinates of the gauge-theory instead of being localized at a point. This will allow us to describe a baryon which is being ‘pulled apart’ into quark constituents.

We start out in Section 3.3 by analysing baryons in a (2+1)-dimensional $SU(N)$ Yang-Mills theory which is obtained from (3+1)-dimensions by compactifying on a supersymmetry breaking circle. As proposed in [55], this gauge theory is dual to a certain non-extremal D3-brane geometry⁴ and, following [12], we study solutions of the D5-brane worldvolume equations of motion in that geometry. We find a class of solutions that are localized in the gauge theory spatial coordinates and appear to describe the baryon. Unlike the baryons constructed in the extremal background [12, 31], these solutions have no moduli since the quarks are truly bound in the baryon. We then study a new class of solutions in which the N quarks are separated into two groups, containing νN and $(1-\nu)N$ quarks respectively, separated by a spatial distance L in the gauge theory. The L -dependence of the energy of these solutions is consistent with confinement and the implied color flux tube tension has a non-trivial dependence on the color charge ν .

3.3.1 Worldvolume Action and Equations of Motion

We derive the equations for a D5-brane embedded in the near-horizon geometry of N nonextremal D3-branes. The Euclidean background metric is

$$ds^2 = \left(\frac{r}{R}\right)^2 [f(r)d\tau^2 + dx_{\parallel}^2] + \left(\frac{R}{r}\right)^2 f(r)^{-1} dr^2 + R^2 d\Omega_5^2, \quad (3.22)$$

$$f(r) = 1 - r_h^4/r^4, \quad R^4 = 4\pi g_s N l_s^4, \quad r_h = \pi R^2 T,$$

⁴See [58, 59, 60] for some interesting alternative string theory approaches to the study of large- N non-supersymmetric Yang-Mills theories.

where $\{\tau, x_{||}\} = \{\tau, x, y, z\}$ denote the directions parallel to the threebranes. The coordinate τ is periodic, with period $1/T$, where T is the Hawking temperature. The relation between the horizon radius r_h and T ensures smoothness of the geometry at $r = r_h$.

Under the *AdS/CFT* correspondence [43, 44, 45], type IIB string theory on a background with the above metric, a constant dilaton, and N units of fiveform flux through the five-sphere, is dual to $\mathcal{N} = 4$, $d = 3 + 1$ $SU(N)$ SYM theory at temperature T , with coupling $g_{YM_4}^2 = 2\pi g_s$. The gauge theory coordinates are $\{x, y, z, \tau\}$. For large T the τ circle becomes small and one effectively obtains a description of a strongly-coupled (coupling $g_{YM_3}^2 = g_{YM_4}^2 T$) three-dimensional Euclidean gauge theory at zero temperature. The thermal boundary conditions on the circle break supersymmetry and the fermions and scalars acquire masses of order T and $g_{YM_4}^2 T$, respectively. The effective three-dimensional theory is expected to display behavior similar to that of non-supersymmetric pure Yang-Mills theory, QCD_3 [55].

A baryon (a bound state of N external quarks) in the three-dimensional theory has as its string theory counterpart a fivebrane wrapped on an \mathbf{S}^5 on which N fundamental strings terminate [46, 47]. The fivebrane worldvolume action is

$$S = -T_5 \int d^6\sigma \sqrt{\det(g + F)} + T_5 \int A_{(1)} \wedge G_{(5)} ,$$

where $T_5 = 1/(g_s(2\pi)^5 l_s^6)$ is the brane tension. The Born-Infeld term involves the induced metric g and the $U(1)$ worldvolume field strength $F_{(2)} = dA_{(1)}$. The second term is the Wess-Zumino coupling of the worldvolume gauge field $A_{(1)}$ to (the pullback of) the background five-form field strength $G_{(5)}$, which effectively endows the fivebrane with a $U(1)$ charge proportional to the \mathbf{S}^5 solid angle that it spans.

For a static baryon we need a configuration invariant under translations in the gauge theory time direction, which we take to be y . We parametrize the world volume of the fivebrane by six parameters $\tau, \sigma_1, \sigma_2, \sigma_3, \sigma_4$ and s . The embedding of this

fivebrane into 10-dimensional target space is defined by

$$\begin{aligned}
x &= x(s), & \theta_1 &= \sigma_1, \\
y &= \tau, & \theta_2 &= \sigma_2, \\
z &= \text{Const} = 0, & \theta_3 &= \sigma_3, \\
t &= \text{Const} = 0, & \theta_4 &= \sigma_4, \\
r &= r(s), & \theta_5 &= \theta(s),
\end{aligned} \tag{3.23}$$

where only x , θ_5 and r are functions of the parameter s . This restricts our attention to $SO(5)$ symmetric configurations, i.e. the ones invariant under rotations about the principal polar axis with respect to which θ_5 is measured. The action then simplifies to

$$S = T_5 \Omega_4 R^4 \int d\tau ds \sin^4 \theta \left\{ -\sqrt{r^2 \theta'^2 + r'^2 / f(r) + (r/R)^4 x'^2 - F_{y\theta}^2} + 4A_y \theta' \right\}, \tag{3.24}$$

where $\Omega_4 = 8\pi^2/3$ is the volume of the unit four-sphere.

The gauge field equation of motion following from this action reads

$$\partial_\theta D(\theta) = -4 \sin^4 \theta,$$

where the dimensionless displacement D is the variation of the action with respect to $E = F_{y\theta}$. Note, that $F_{y\theta}$ originally was a magnetic field in the 4-dimensional theory, but became the electric field in the three-dimensional theory, since y plays now the role of time.

The solution to this equation is

$$D(\theta) = \left[\frac{3}{2}(\nu\pi - \theta) + \frac{3}{2} \sin \theta \cos \theta + \sin^3 \theta \cos \theta \right]. \tag{3.25}$$

As will be explained below, the integration constant $0 \leq \nu \leq 1$ controls the number of Born-Infeld strings emerging from each pole of the \mathbf{S}^5 . Next, it is convenient to eliminate the gauge field in favor of D and Legendre transform the original Lagrangian to obtain an energy functional of the embedding coordinate $r(\theta)$ only:

$$U = T_5 \Omega_4 R^4 \int ds \sqrt{r^2 \theta'^2 + r'^2 / f(r) + (r/R)^4 x'^2} \sqrt{D(\theta)^2 + \sin^8 \theta}. \tag{3.26}$$

This action has the interesting scaling property that if $\{r(s), \theta(s), x(s)\}$ is a solution for horizon radius r_h , then $\{\alpha r(s), \theta(s), \alpha^{-1}x(s)\}$ is a solution for horizon radius αr_h . The scaling $x \propto R^2/r$ is precisely as expected from the holographic UV/IR relation [53, 54]. We will have more to say about scaling behavior of solutions later on.

The fivebrane embeddings of interest to us will have singularities: places on the five-sphere (typically $\theta \rightarrow \pi$ or 0) where $r \rightarrow \infty$ and $x' \rightarrow 0$. As in [12, 6, 7], these ‘spikes’ must be interpreted as bundles of fundamental strings attached to the wrapped fivebrane and localized at some definite value of x . It can be seen from (3.26) that a spike sticking out at $\theta = \pi$ has a ‘tension’ (energy per unit radial coordinate distance) $T_5 \Omega_4 R^4 |D(\pi)| f(r)^{-1/2} = (1-\nu) N T_F f(r)^{-1/2}$, which is precisely the tension of $(1-\nu)N$ fundamental strings in this geometry. A spike at $\theta = 0$ has the same tension as νN strings so that, taken together, the two singularities represent a total of N fundamental strings, as expected. Surfaces with more singularities and less symmetry are perfectly possible, but a lot harder to analyze. To keep things manageable, we have built $SO(5)$ symmetry into the ansatz.

In the extremal case ($r_h = 0$) discussed in [12], the BPS condition provided a first integral which greatly simplified the analysis. In the nonextremal case we are now discussing, there is no such first integral and we have to deal with the unpleasant second order Euler-Lagrange equation that follows from (3.26). This is most conveniently done in a parametric Hamiltonian formalism⁵. Let us introduce the momenta conjugate to r , θ and x

$$p_r = f^{-1} \dot{r} \Delta, \quad p_\theta = r^2 \dot{\theta} \Delta, \quad p_x = (r/R)^4 \dot{x} \Delta, \quad \Delta = \frac{\sqrt{D^2 + \sin^8 \theta}}{\sqrt{r^2 \dot{\theta}^2 + \dot{r}^2 / f + (r/R)^4 \dot{x}^2}} . \quad (3.27)$$

The Hamiltonian that follows from the action (3.26) vanishes identically due to reparametrization invariance in s . Furthermore, the momentum expressions are non-

⁵We would like to thank G. Savvidy for suggesting and helping to realize this approach.

invertible and the system is subject to the constraint

$$2\tilde{H} = \left(1 - \frac{r_h^4}{r^4}\right) p_r^2 + \frac{p_\theta^2}{r^2} + \frac{R^4}{r^4} p_x^2 - (D^2 + \sin^8 \theta) = 0 . \quad (3.28)$$

This constraint can be taken as the Hamiltonian and this choice conveniently fixes the gauge, while getting rid of the complicated square-root structure of the action. The equations of motion that follow from this Hamiltonian are

$$\begin{aligned} \dot{r} &= \left(1 - \frac{r_h^4}{r^4}\right) p_r , & \dot{p}_r &= \frac{2}{r^5} (p_x^2 R^4 - p_r^2 r_h^4) + \frac{p_\theta^2}{r^3} , \\ \dot{\theta} &= \frac{p_\theta}{r^2} , & \dot{p}_\theta &= -6 \sin^4 \theta (\pi\nu - \theta + \sin \theta \cos \theta) , \\ \dot{x} &= \frac{R^4}{r^4} p_x , & \dot{p}_x &= 0 . \end{aligned} \quad (3.29)$$

Together with initial conditions, these equations completely define the solutions for the fivebrane. The initial conditions should be chosen such that $\tilde{H} = 0$.

To gain some insight into the solutions to these equations, notice that the basic problem to solve is a motion in the two-dimensional $r - \theta$ plane: the motion in x is then determined by the choice of a conserved value for p_x . Note that for $p_x = 0$, the surface sits at a fixed value of x and therefore has no spatial extension in the gauge theory coordinates: we will call this a ‘point’ solution. When r is large compared to r_h and $R\sqrt{p_x}$, the $(r\theta)$ motion is simply that of a particle of unit mass moving in two dimensions under the influence of the potential $V(\theta) = -[D(\theta)^2 + \sin^8 \theta]$. By the constraint, the energy of this fictitious particle vanishes. For generic ν , the potential has three extrema (see Figure 3.6): two minima at $\theta = 0$ and $\theta = \pi$, and a maximum at $\theta = \theta_c$ such that $\pi\nu = \theta_c - \sin \theta_c \cos \theta_c$. For large r the particle will thus roll down towards one of the two minima. Whether it reaches $\theta = 0, \pi$ at a finite value of r depends on the initial boundary conditions.

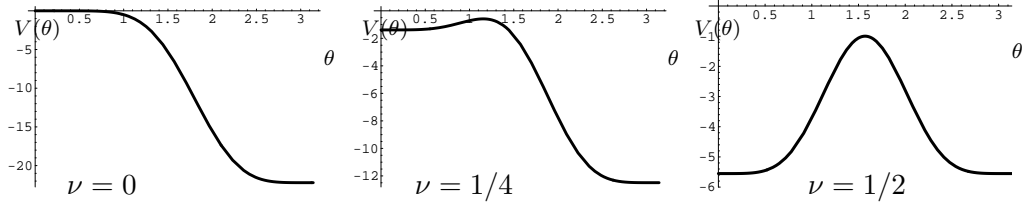

Figure 3.6: The potential $V(\theta) = -[D(\theta)^2 + \sin^8 \theta]$ for $\nu = 0, 1/4, 1/2$ (see text for discussion).

3.3.2 The Point Baryon

In this section we study solutions which correspond to a baryon localized at a particular gauge theory position. To localize the surface in x , we just set $p_x = 0$. With the symmetry that we have built in, the equations of motion typically allow the surface to run off to $r = \infty$ at $\theta = \pi$ or 0 . At least asymptotically, such ‘spikes’ are equivalent to bundles of fundamental strings and will be identified with the quark constituents of the state represented by the wrapped fivebrane. To get a baryon whose component quarks have identical $SU(4)$ (flavor) quantum numbers, we want a spike representing N quarks to emerge from one pole of the S^5 (say $\theta = \pi$) with a smooth surface at the other pole. To meet the first condition, it suffices to set the integration constant $\nu = 0$ and to meet the second, we impose smooth boundary conditions ($\partial_\theta r = 0$ and $r = r_0$) at $\theta = 0$.⁶

Numerical integration with these boundary conditions yields a one-parameter family of solutions (parametrized by r_0). Due to the scaling mentioned before, the solutions really only depend on r_h through the ratio $\zeta = r_0/r_h \geq 1$. Figure 3.7 shows polar plots⁷ of the solutions for a few representative values of ζ . When $\zeta < \zeta_{crit} \approx 9$ the solution tilts toward and eventually crosses the symmetry axis, thus reaching $\theta = \pi$ at a finite

⁶This is equivalent to requiring $p_r = 0$ at $\theta = 0$, in which case p_θ must also vanish to satisfy the constraint (3.28).

⁷Although these plots provide a conveniently simple representation of the solutions, the reader should bear in mind that they are a bit misleading as to the intrinsic geometry, since the radius of the S^5 is R , independent of r .

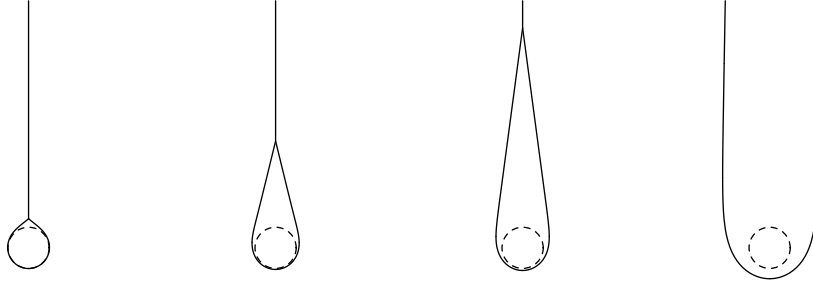

Figure 3.7: Family of solutions illustrating the progressive deformation of the fivebrane by the bundle of N fundamental strings. The dotted circle represents the horizon. The stable configuration is a ‘tube’ with $r_0 \rightarrow \infty$.

value of r . As $\zeta \rightarrow 1$ (i.e. as the starting radius gets closer and closer to the horizon), the brane becomes more and more spherical (notice that $r(\theta) = r_h$ is a solution to the equations of motion). For $\zeta > \zeta_{crit}$, on the other hand, the solution tilts away from the symmetry axis, reaching $\theta = \pi$ only at $r = \infty$. As ζ increases the solution looks more and more like a ‘tube’. This is simply a consequence of the fact that, for large ζ , the solution is always very far from the horizon, and is well-approximated by an extremal embedding (discussed in [12]). When $\zeta \rightarrow \infty$ the configuration becomes a BPS ‘tube’ [12] with infinite radius.

The cusp in the $\zeta < \zeta_{crit}$ solutions indicates the presence of a delta-function source in the equations of motion. Since the compactly wrapped brane intercepts N units of five-form flux, it has N units of worldbrane $U(1)$ charge and must have N fundamental strings attached to it [46]. This is most simply achieved by taking the cusp as the point of attachment of N fundamental strings, running along the ray $\theta = \pi$. In accordance with the Born-Infeld string philosophy [6, 7], these strings are equivalent to a D5-brane wrapped on an S^4 of vanishing volume which carries the $U(1)$ flux out to infinity. A simple modification of the flat space argument [10, 6, 7] shows that such a collapsed fivebrane is a solution to the equations of motion and has ‘tension’ $NT_F f(r)^{-1/2}$ (exactly the tension exerted by a fundamental string of intrinsic tension T_F in this curved space).

The entire fivebrane-string (or collapsed brane) system will be stable only if there is tension balance between its two components. To obtain the stability condition, let r_c denote the location of the cusp (which is a function of r_0), and parametrize the family of fivebrane embeddings as $r = r(\theta; r_c)$. Under the variation $r_c \rightarrow r_c + \delta r_c$, it can be seen from (3.26), after an integration by parts and application of the Euler-Lagrange equation, that the energy of the brane changes only by a surface term,

$$\frac{\partial U}{\partial r_c} = T_5 \Omega_4 R^4 \frac{r' \sqrt{D^2 + \sin^8 \theta}}{f \sqrt{r^2 + f(r)^{-1} r'^2}} \frac{\partial r}{\partial r_c} \Big|_0^\pi = \frac{N T_F f(r_c)^{-1/2}}{\sqrt{1 + f(r_c) r_c^2 / r_c'^2}}, \quad (3.30)$$

where $r'_c = \partial_\theta r|_{\theta=\pi}$, and we have used the fact that $r(\pi; r_c) = r_c$. The numerator in the last expression of (3.30) is the ‘tension’ at $r = r_c$ of N fundamental strings, so it is clear that the brane has a lower tension for any $r_c > r_h$. The energy is lowered by expanding the fivebrane and shortening the explicit fundamental string. A similar variational calculation applied to the $\zeta > \zeta_{crit}$ configurations (cut off at a large $r = r_{max}$) shows that the BPS ‘tube’ at infinity is the lowest energy solution. This is consistent with the results of [48], where the baryon was examined using the pure Nambu-Goto action for the fivebrane wrapped on a sphere. We emphasize that the above variational calculation used solutions of the full Born-Infeld (plus Wess-Zumino) action.

Altogether, then, the solutions depicted in Fig. 3.7 provide a physically satisfying picture of the process through which the N fundamental strings deform the initially spherical fivebrane, pulling it out to infinity. The final configuration has the shape of a ‘tube’, just like the BPS embeddings found in [31, 12]. In the supersymmetric case, r_0 was a modulus and the energy of the baryon was independent of the overall scale of the solution. In the nonextremal case examined here, however, there appears to be a potential for that modulus which drives the stable solution out to $r_0 \rightarrow \infty$.

The dependence of the fivebrane embedding on the S^5 coordinates encodes the flavor structure (i.e., the $SU(4)$ quantum numbers) of the gauge theory state under

consideration. As a result of the UV/IR relation, the *AdS* radial coordinate r is associated with an energy scale in the gauge theory, $E = r/R^2$ [53, 54]. The embedding $r(\theta)$ consequently associates a particular value of θ to each different distance scale, yielding some sort of $SU(4)$ wavefunction for the baryon. The $SO(5)$ symmetry of the embedding translates into the statement that the baryon is a singlet under the corresponding $SU(4)$ subgroup. Finally, the fact that a given surface spans the range $r \geq r_0$ implies that the dual gauge theory configuration has structure on all length scales from zero up to a characteristic size R^2/r_0 . Since the energetically preferred configuration has $r_0 \rightarrow \infty$, it is in this sense truly pointlike.

3.3.3 The Split Baryon: Color Dependence of the String Tension

We now turn our attention to solutions with $p_x \neq 0$ (i.e. $x' \neq 0$). They describe collections of quarks at finite separation in the gauge theory position space and are of interest for exploring confinement issues. It turns out to be rather easy to construct a surface describing an $SU(N)$ baryon split into two distinct groups, containing νN and $(1 - \nu)N$ quarks respectively and separated by a distance L in the x direction. In a confining $SU(N)$ gauge theory, two such quark bundles should be connected by a color flux tube and we will study the Born-Infeld representation of this phenomenon. Each group of quarks corresponds as before to a bundle of Born-Infeld strings, realized in our approach as a singular spike or fivebrane ‘tube’ with topology $\mathbf{R} \times \mathbf{S}^4$. Remember that we have assumed an $SO(5)$ -symmetric configuration, which means that the two singularities representing the quarks must be located at opposite poles of the \mathbf{S}^5 (we will put them at $\theta = 0$ and $\theta = \pi$) with corresponding implications about the $SU(4)$ flavor structure of the states we are constructing. More general flavor structures are possible, but we will not try to study these more complicated surfaces. For large spatial separation $L = |x(\infty) - x(-\infty)|$, the portion of the fivebrane that interpolates between

the two string bundles runs close to the horizon and it is this part of the surface that encodes the confining flux tube of the gauge theory. The surface equations (3.29) imply that the part of the surface that has large spatial extent must sit at a constant $\theta = \theta_c$ where $\dot{p}_\theta = 0$. More precisely, it has to sit at the solution of

$$\pi\nu = \theta_c - \sin\theta_c \cos\theta_c . \quad (3.31)$$

corresponding to the unstable maximum of the potential $V(\theta)$ discussed at the end of Section 3.3.1. The critical angle is a monotonic function of ν , such that $\theta_c(0) = 0$ and $\theta_c(\nu) = \pi - \theta_c(1 - \nu)$. The energetics of the part of the fivebrane that encodes the confining flux tube will depend on θ_c , and therefore ν , in a way that we will now examine in some detail.

Unfortunately, we must resort to numerical analysis to construct specific surfaces of this kind. It is convenient to take the point of closest approach to the horizon as the starting point for the numerical integration. We start the integration off with the initial conditions

$$\begin{aligned} r(0) &= r_h + \epsilon , & p_r(0) &= 0 , \\ \theta(0) &= \theta_c , & p_\theta(0) &= \eta , \\ x(0) &= 0 , & p_x(0) &= (r(0)/R)^2 \sqrt{\sin^6\theta_c - (\eta/r(0))^2} . \end{aligned} \quad (3.32)$$

The distance from the horizon at the point of closest approach is controlled by ϵ . For a given ϵ , we have to ‘shoot’ in η until we get satisfactory behavior of the quark-like singularities at $\theta \rightarrow 0$ and $\theta \rightarrow \pi$ (see Section 3.3.2 for details). Indeed, it is natural to require asymptotically BPS behavior in the region of space where supersymmetry is recovered locally (i.e., far from the horizon). Once that is done, ϵ controls the spatial separation of the two separated quark bundles. Figs. 3.8 and 3.9 depict a typical fivebrane embedding obtained by numerical integration, for the case $\nu = 0.9$. It can be seen in Fig. 3.8 that the brane extends in the x direction mostly in its ‘flux tube’ portion, at $\theta = \theta_c$ and $r \approx r_h$. The Born-Infeld string ‘tubes’ corresponding to the two groups of quarks lie essentially at a constant value of x .

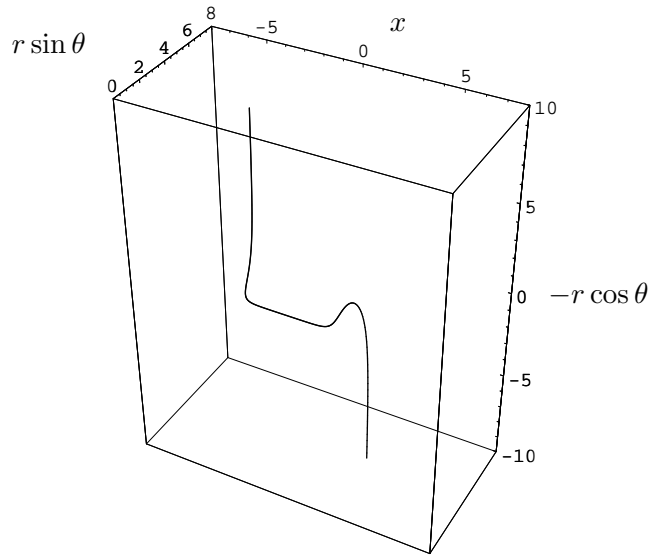

Figure 3.8: The three-dimensional projection of the D5-brane. Every point on the curve is an \mathbf{S}^4 . One can clearly see how the brane drops down towards the horizon, extends horizontally along it, and finally leaves at the other end. From the point of view of the three-dimensional $SU(N)$ gauge theory, which lives in the $\{x, y, z\}$ directions, this configuration represents a baryon split into two groups of νN and $(1 - \nu)N$ quarks (the vertical segments — see Fig. 3.9), connected by a flux tube extending a finite distance along the x direction.

It is seen from the equation for \dot{r} in (3.29) that, for the portion of the brane running close to the horizon, $r(s) - r_h$ grows as an exponential in the parameter s , with an exponent proportional to p_r . The latter reaches a value close to $(R/r_h)p_x$ (see the equation for \dot{p}_r). The equation for \dot{x} then shows that the separation L between the quarks increases only logarithmically with ϵ , the minimal distance to the horizon. In fact, there exists a limiting solution which consists of νN quarks with a flux tube that extends to infinity, and the brane approaches the horizon exponentially with distance.

From the above discussion it is clear that for large quark separation L the (renormalized) energy will receive its main contribution from the flux tube, and will consequently depend linearly on L , a clear indication of confinement. It is easy to compute the tension (energy per unit distance in x) of the color flux tube. Note that when the

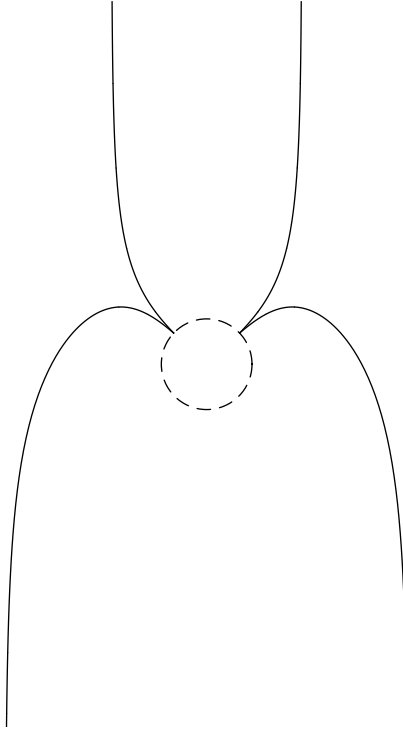

Figure 3.9: Polar plot of $r(\theta)$ – the two-dimensional projection of Fig. 3.8. The Born-Infeld string ‘tubes’ pointing up and down represent two groups of νN and $(1 - \nu)N$ quarks, respectively (with $\nu = 0.9$ here). The brane extends in the x -direction mostly at the inflection point (the cusp), while x is essentially constant along the tubes.

fivebrane runs parallel and close to the horizon, the energy function (3.26) reduces to

$$U_{flux} = \frac{2}{3\pi} NT_F \int dx \left(\frac{r}{R} \right)^2 \sqrt{D^2 + \sin^8 \theta} .$$

Using $r \simeq r_h$, $\theta \simeq \theta_c$, and performing some simple manipulations using the definitions of θ_c (3.31) and $D(\theta)$ (3.25), one obtains the tension

$$\sigma_3(\nu) = \frac{2}{3\pi} NT_F \left(\frac{r_h}{R} \right)^2 \sin^3 \theta_c = \frac{\sqrt{2}}{3} N \sqrt{g_{Y M_3}^2} NT^{3/2} \sin^3 \theta_c , \quad (3.33)$$

where the last expression is given solely in terms of parameters of the gauge theory in three dimensions. Since it is obtained by dimensional reduction from four dimensions, this theory should be understood to have an ultraviolet cutoff proportional to the Hawking temperature T . The dependence of the tension on T , N , and the ’t Hooft

coupling $\lambda_3 = g_{YM_3}^2 N$ agrees with the result of [48], where a baryon whose component quarks lie on a circle is treated within a simplified Nambu-Goto approach.

Notice that, in addition, equation (3.33) gives the dependence of the flux tube tension on ν , i.e. on its color content. This nontrivial dependence, arising entirely from the factor $\sin^3 \theta_c$, is plotted in Fig. 3.10:

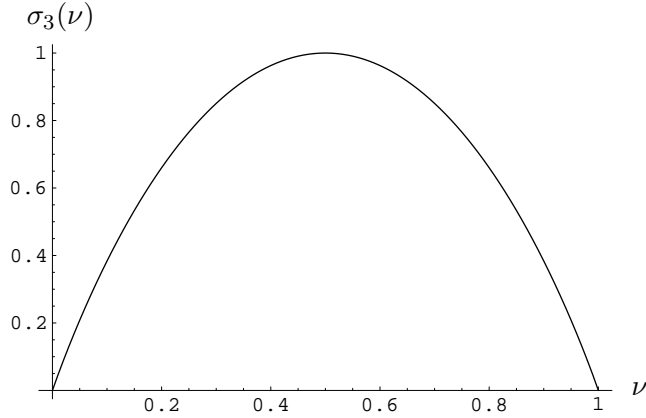

Figure 3.10: The tension of the flux tube (normalized to unity at its peak) as a function of ν , the fraction of quarks pulled apart. In the full theory ν should be quantized in units of $1/N$. See text for discussion.

Let us discuss the features of the flux tube tension seen in Fig. 3.10. As one might expect, the tension increases linearly for small ν . This means that for each additional quark removed the work done is approximately constant. Also as expected, in expression (3.33) there is a complete symmetry between ν and $1 - \nu$, (i.e., it makes no difference whether n or $N - n$ quarks are pulled out). Thus, the tension has a maximum at $\nu = 1/2$ and comes back down to zero near $\nu = 1$. In gauge theory language, the flat part of the curve means that it does not cost any energy to move the quark from one bundle with $\sim N/2$ quarks to the other.

Notice from equation (3.31) that $\sin^3 \theta_c \simeq 3\pi\nu/2$ for small ν . This implies that $\sigma_3(\nu = 1/N)$ becomes *independent* of N in the 't Hooft limit $N \rightarrow \infty$ with λ_3 fixed. This result has a natural gauge theory interpretation. When one quark is pulled out

from the $SU(N)$ baryon (a color-singlet), the remaining $N - 1$ must be in the anti-fundamental representation of the gauge group. The flux tube extending between this bundle and the solitary quark should then have the same properties as the standard QCD string which connects a quark and an antiquark. In particular, its tension should depend on N only through the 't Hooft coupling, as we have found. As a matter of fact, for $\nu = 1/N \ll 1$ equation (3.33) precisely agrees with the quark-antiquark string tension which follows from a Nambu-Goto string calculation [49]. More generally, for $\nu = n/N$, with n fixed as $N \rightarrow \infty$, expression (3.33) reduces to the tension of n quark-antiquark strings.

It is important to note that, as has been pointed out by various authors, the gauge theory under study here is not strictly three-dimensional [49, 47]. The energy scale associated with the QCD string tension, for instance, is proportional to $\lambda_4^{1/4} T$, where $\lambda_4 = g_{YM_4}^2 N$. This is much larger than the compactification scale T in the large λ_4 regime where the supergravity approximation is appropriate.

Conclusion

In conclusion I would like to sum up what has been done in this thesis, and point out some interesting possible extensions of our work.

In the second Chapter I conclusively show the broad applicability of the Born-Infeld action to static and dynamical questions in string theory.

In the third Chapter I present the work done in collaboration with C. Callan, A. Guijosa, and Ø. Tafjord on application of the B-I fivebrane worldvolume action to the AdS/CFT correspondence. We construct a non-perturbative object of gauge theory, namely the baryon vertex.

Our description of the Hanany-Witten phenomenon raises a very interesting question which I would like to explore in the future, whether the half-string state that can be conveniently described by our B-I wrapped brane has in fact reality to it, i.e. what are the dynamical consequences of such an object, and its place in perturbative string theory.

In the second part of the Chapter I present our work on the supergravity/gauge theory correspondence in the case of non-extremal background. Here we were able to measure the tension of the color flux tubes, and its dependence on the number of quarks removed from the baryon to a finite distance.

The possible extension of these efforts to get a handle at weakly coupled non-supersymmetric theory would be to the new ideas coming from type 0A and 0B theories [58, 59, 60]. In these theories spacetime fermions are absent from the very beginning and there is no need to invent ways to decouple them. Moreover there are solutions to the gravity equations which have a running dilaton, and on the gauge theory side the running coupling matches exactly the expectation from ordinary QCD.

It is at present too early to comment on the validity of this approach, for example because of the problems associated with the presence of the tachyon in the low energy spectrum.

Acknowledgements Before everyone else my Parents, Natalia and George,

and my brother Pavlos have given me the most valuable support and encouragement whenever it was most needed. Also, the people of my extended family have been a model of what a big heart, golden hands and hard work can achieve. It is to that simple model that I strive to measure up to.

I would like to thank everybody at Princeton who I worked with, was helped by, or just socialized. I have changed much and learned much over these years both scientifically and otherwise. The people who are most responsible for this, and to whom I am most thankful are my advisor Curtis Callan, as well as Igor Klebanov and Larus Thorlacius. Earlier I benefited tremendously from discussions with David Gross, Washington Taylor, and Matt Strassler.

Also, many thanks to the students in our department, discussions with whom played a big role in learning things: my coworkers Alberto Guijosa and Oyvind Tafjord; John Brodie, Andrei Mikhailov, Shiraz Minwalla, Sangmin Lee, Vamsi Madhav, Maulik Parikh, Morten Krogh, Aki Hashimoto, Steve Gubser, Sergei Gukov, Victor Gurarie, Michael Krasnitz, Juan Maldacena, Matt Hastings, Edna Cheung and several others.

I would also like to thank my friends who are too numerous to list all, Dimitris Kyritsis, Alexandros Michaelides, Angelos Bilas, Andromache Karanika, Diego Casa, Sanjay Ram, Tina Pavlin, Jacqui Hall, Marianna Shlyakhova, Paul Shultz, Jamie Fumo, Areg and Shooshan Danagoulian, Dima Oulianov, Cristina and Jorge Silva, Sasha Shekochikhin, Florin Spinu, Bogdan Ion, Evi, Anthi, George, Alexis, Max Perelstein, Billy Bridges, Elcin Yildirim, Partha Nandi, Don Priour, Antonio Garcia, Davee Datta, Stas Boldyrev, Anagha Neelakantan and many others.

Bibliography

- [1] M. Born and L. Infeld, “Foundations Of The New Field Theory,” Proc. Roy. Soc. Lond. **A144**, 425 (1934). ;
- [2] P.A. Dirac, “An Extensible Model Of The Electron,” Proc. Roy. Soc. Lond. **A268**, 57 (1962).
- [3] J. Dai, R.G. Leigh, J. Polchinski, “New connections between string theories,” Mod. Phys. Lett. **A4** (1989) 2073
- [4] R.G. Leigh, “Dirac-Born-Infeld action from Dirichlet sigma model,” Mod. Phys. Lett. **A4** (1989) 2767
- [5] J. Polchinski, “Dirichlet-Branes and Ramond-Ramond Charges,” Phys.Rev.Lett. **75** (1995) 4724, [hep-th/9510017](#).
- [6] C. Callan and J. Maldacena, “Brane Dynamics from the Born-Infeld Action,” Nucl. Phys. **B513** (1998) 198, [hep-th/9708147](#).
- [7] G. Gibbons, “Born-Infeld Particles and Dirichlet p-branes”, Nucl. Phys. **B514** (1998) 603, [hep-th/9709027](#).
- [8] K.G. Savvidy and G.K. Savvidy, “Neumann boundary conditions from Born-Infeld dynamics,” [hep-th/9902023](#).
- [9] K.G. Savvidy, “Brane death via Born-Infeld string,” [hep-th/9810163](#).
- [10] R. Emparán, “Born-Infeld Strings Tunneling to D-branes,” Phys. Lett. **B423** (1998) 71, [hep-th/9711106](#).

- [11] T. Banks and L. Susskind, “Brane - anti-brane forces,” hep-th/9511194.
 - [12] C.G. Callan, A. Guijosa and K.G. Savvidy, “Baryons and string creation from the five-brane world volume action,” hep-th/9810092.
 - [13] C.G. Callan, A. Guijosa, K.G. Savvidy and O. Tafjord, “Baryons and flux tubes in confining gauge theories from brane actions,” hep-th/9902197.
 - [14] G.W. Gibbons, M.B. Green and M.J. Perry, “Instantons and seven-branes in type IIB superstring theory,” Phys. Lett. **B370**, 37 (1996) hep-th/9511080.
 - [15] J.H. Schwarz, “Covariant Field Equations Of Chiral N=2 D = 10 Supergravity,” Nucl. Phys. **B226**, 269 (1983).
 - [16] L. Brink and J.H. Schwarz, “Quantum Superspace,” Phys. Lett. **100B**, 310 (1981).
 - [17] M.B. Green and J.H. Schwarz, “Covariant Description Of Superstrings,” Phys. Lett. **136B**, 367 (1984).
 - [18] E. Bergshoeff, E. Sezgin and P.K. Townsend, “Supermembranes And Eleven-Dimensional Supergravity,” Phys. Lett. **B189**, 75 (1987).
 - [19] P.K. Townsend, “The eleven-dimensional supermembrane revisited,” Phys. Lett. **B350**, 184 (1995) hep-th/9501068.
 - [20] J. Hughes, J. Liu and J. Polchinski, “Supermembranes,” Phys. Lett. **180B**, 370 (1986).
 - [21] W. Siegel, “Hidden Local Supersymmetry In The Supersymmetric Particle Action,” Phys. Lett. **128B**, 397 (1983).
 - [22] A. Dabholkar and J.A. Harvey, “Nonrenormalization Of The Superstring Tension,” Phys. Rev. Lett. **63**, 478 (1989).
- A. Dabholkar, G. Gibbons, J.A. Harvey and F. Ruiz Ruiz, “Superstrings And Solitons,” Nucl. Phys. **B340**, 33 (1990).

- [23] E.S. Fradkin and A.A. Tseytlin, “Effective Action Approach To Superstring Theory,” *Phys. Lett.* **160B**, 69 (1985).
E.S. Fradkin and A.A. Tseytlin, “Quantum String Theory Effective Action,” *Nucl. Phys.* **B261**, 1 (1985).
- [24] A. Abouelsaood, C.G. Callan, C.R. Nappi and S.A. Yost, “Open Strings In Background Gauge Fields,” *Nucl. Phys.* **B280**, 599 (1987).
- [25] T. Hagiwara, “A Nonabelian Born-Infeld Lagrangian,” *J. Phys.* **A14**, 3059 (1981).
- [26] P.C. Argyres and C.R. Nappi, “Spin 1 Effective Actions From Open Strings,” *Nucl. Phys.* **B330**, 151 (1990).
- [27] A.A. Tseytlin, “On nonAbelian generalization of Born-Infeld action in string theory,” *Nucl. Phys.* **B501**, 41 (1997) hep-th/9701125.
- [28] A.A. Tseytlin, “Vector Field Effective Action In The Open Superstring Theory,” *Nucl. Phys.* **B276**, 391 (1986).
- [29] G.K. Savvidy, “Infrared Instability Of The Vacuum State Of Gauge Theories And Asymptotic Freedom,” *Phys. Lett.* **71B**, 133 (1977).
S.G. Matinian and G.K. Savvidy, “Vacuum Polarization Induced By The Intense Gauge Field,” *Nucl. Phys.* **B134**, 539 (1978).
- [30] Soo-Jong Rey, Jungtae Yee, “Macroscopic Strings as Heavy Quarks of Large N Gauge Theory and Anti-de Sitter Supergravity”, hep-th/9803001.
- [31] Y. Imamura, “Supersymmetries and BPS Configurations on Anti-de Sitter Space,” hep-th/9807179.
- [32] C.G. Callan, A. Guijosa, K.G. Savvidy, “Baryons and String Creation,” hep-th/9810092
- [33] R. Emparan, “Born-Infeld Strings Tunneling to D-branes,” hep-th/9711106
- [34] J. Maldacena, “Wilson loops in large N field theories,” hep-th/9803002

- [35] M. Aganagic, C. Popescu, J.H. Schwarz, “Gauge-Invariant and Gauge-Fixed D-Brane Actions”, Nucl. Phys. **B495** (1997) 99, [hep-th/9612080](#)
- [36] S. Lee, A. Peet, L. Thorlacius, “Brane-Waves and Strings”, Nucl. Phys. **B514** (1998) 161, [hep-th/9710097](#)
- [37] C.G. Callan, L. Thorlacius, “Worldsheet Dynamics of String Junctions”, Nucl. Phys. **B534** (1998) 121, [hep-th/9803097](#)
- [38] J. Park, “A Study of a non-Abelian generalization of the Born-Infeld action,” [hep-th/9902081](#).
- [39] A. Hashimoto and W.I. Taylor, “Fluctuation spectra of tilted and intersecting D-branes from the Born- Infeld action,” Nucl. Phys. **B503**, 193 (1997) [hep-th/9703217](#).
- [40] A. Dabholkar, G. Gibbons, J.A. Harvey and F. Ruiz Ruiz, “Superstrings And Solitons,” Nucl. Phys. **B340**, 33 (1990).
- [41] G.T. Horowitz and A. Strominger, “Black strings and P-branes,” Nucl. Phys. **B360**, 197 (1991).
- [42] J. Polchinski, “Tasi lectures on D-branes,” [hep-th/9611050](#).
- [43] J. Maldacena, “The Large N Limit of Superconformal Field Theories and Supergravity,” [hep-th/9711200](#).
- [44] S. S. Gubser, I. R. Klebanov, and A. M. Polyakov, “Gauge Theory Correlators from Noncritical String Theory,” Phys. Lett. **B428** (1998) 105, [hep-th/9802109](#).
- [45] E. Witten, “Anti-de Sitter Space and Holography,” [hep-th/9802150](#).
- [46] E. Witten, “Baryons and Branes in Anti de Sitter Space,” JHEP **07** (1998) 006, [hep-th/9805112](#).
- [47] H. Ooguri and D. Gross, “Aspects of Large N Gauge Theory Dynamics as seen by String theory,” [hep-th/9805129](#).

- [48] A. Brandhuber, N. Itzhaki, J. Sonnenschein, and S. Yankielowicz, “Baryons from Supergravity,” [hep-th/9806158](#);
Y. Imamura, “Baryon Mass and Phase Transitions in Large N Gauge Theory,” [hep-th/9806162](#).
- [49] A. Brandhuber, N. Itzhaki, J. Sonnenschein, and S. Yankielowicz, “Wilson Loops, Confinement, and Phase Transitions in Large N Gauge Theories from Supergravity,” *J. High Energy Phys.* **06** (1998) 001, [hep-th/9803263](#).
- [50] A. Hanany and E. Witten, “Type IIB superstrings, BPS Monopoles, and Three-dimensional Gauge Dynamics,” *Nucl. Phys.* **B492** (1997) 152, [hep-th/9611230](#).
- [51] C. P. Bachas, M. R. Douglas, and M. B. Green, “Anomalous Creation of Branes,” *J. High Energy Phys.* **07** (1997) 002, [hep-th/9705074](#).
- [52] U. Danielsson, G. Ferretti, and I. Klebanov, “Creation of Fundamental Strings by Crossing D-branes,” *Phys. Rev. Lett.* **79** (1997) 1984, [hep-th/9705084](#).
- [53] L. Susskind and E. Witten, “The Holographic Bound in Anti-de Sitter Space,” [hep-th/9805114](#).
- [54] A. W. Peet and J. Polchinski, “UV/IR Relations in AdS Dynamics,” [hep-th/9809022](#).
- [55] E. Witten, “Anti-de Sitter Space, Thermal Phase Transition, and Confinement in Gauge Theories,” *Adv. Theor. Math. Phys.* **2** (1998) 505, [hep-th/9803131](#).
- [56] Y. Imamura, “Supersymmetries and BPS Configurations on Anti-de Sitter Space,” [hep-th/9807179](#).
- [57] A. Hashimoto, “The Shape of Branes Pulled by Strings,” [hep-th/9711097](#).
- [58] A. M. Polyakov, “The Wall of the Cave,” [hep-th/9809057](#);
I. R. Klebanov and A. A. Tseytlin, “D-Branes and Dual Gauge Theories in Type 0 Strings,” [hep-th/9811035](#);

- I. R. Klebanov and A. A. Tseytlin, “Asymptotic Freedom and Infrared Behavior in the Type 0 String Approach to Gauge Theory,” [hep-th/9812089](#).
- [59] J. A. Minahan, “Glueball Mass Spectra and Other Issues for Supergravity Duals of QCD Models,” [hep-th/9811156](#);
J. A. Minahan, “Asymptotic Freedom and Confinement from Type 0 String Theory,” [hep-th/9902074](#).
- [60] C. Csaki, Y. Oz, J. Russo, and J. Terning, “Large N QCD from Rotating Branes,” [hep-th/9810186](#);
A. Kehagias and K. Sfetsos, “On running couplings in gauge theories from type-IIB supergravity,” [hep-th/9902125](#).