

R&D for a CCD Vertex Detector for the High Energy Linear e^+e^- Collider

P.N. Burrows*
Oxford University

(Representing the LCFI (UK) Collaboration)
 (Dated: November 21, 2018)

I summarise the status of the LCFI Collaboration R&D programme for a CCD-based vertex detector for the linear collider.

I. INTRODUCTION

Charge-coupled devices (CCDs) were originally applied in high-energy particle physics at a fixed-target charm-production experiment, and their utility for high-precision vertexing of short-lived particles was quickly realised [1]. More recently two generations of CCD vertex detectors (VXD) were used in the e^+e^- colliding-beam environment of the SLD experiment at the first linear collider, SLC, at SLAC.

CCDs are silicon pixel devices which are widely used for imaging; one common application is in home video cameras, and there is extensive industrial manufacturing experience in Europe, Japan and the US. CCDs can be made with high pixel granularity. For example, those used at SLD comprise $20 \times 20 \mu\text{m}^2$ pixels, offering the possibility of intrinsic space-point resolution of better than $3 \mu\text{m}$, determined from the centroid of the small number of pixels which are hit when a charged particle traverses the device. The active depth in the silicon is only $20 \mu\text{m}$, so each pixel is effectively a cube of side $20 \mu\text{m}$, yielding true 3-dimensional spatial information. Furthermore, this small active depth allows CCDs to be made very thin, ultimately perhaps as thin as $20 \mu\text{m}$, which corresponds to significantly less than 0.1% radiation length (X_0), and yields a very small multiple scattering of charged particles. Also, large-area CCDs can be made for scientific purposes, allowing an elegant VXD geometry with no azimuthal gaps or dead-zones for readout cables or support structures.

The combination of superb spatial resolution, low multiple scattering, and large-area devices, with a decade of operating experience at SLC, makes CCDs a very attractive option for use in a vertex detector at the next-generation linear collider (LC).

II. SLD CCD VXD EXPERIENCE

The SLD experiment has utilised three CCD arrays for heavy-flavour tagging in Z^0 decays. In 1991 a 3-ladder prototype detector, VXD1, was installed for initial operating experience. In 1992 a complete four-layer detector, VXD2, was installed and operated until 1995. VXD2 [2] utilised 64 ladders arranged in 4 incomplete azimuthal layers, with ≥ 2 -hit coverage extending down to polar angles within $|\cos\theta| \leq 0.75$. The device contained 512 roughly $1 \times 1 \text{cm}^2$ CCDs, giving a total of 120M pixels.

In 1996 a brand new detector, VXD3 [3], was installed. The main improvement was to utilise much larger, $8 \times 1.6 \text{cm}^2$, and thinner ($\times 3$) CCDs, which allowed significantly improved azimuthal- and polar-angle coverage. Ladders were formed from two CCDs placed end-to-end (with a small overlap in coverage) on opposite sides of a beryllium support beam, and arranged in 3 complete azimuthal layers, with a ‘shingled’ geometry to ensure no gaps in azimuth. 96 CCDs were used, giving a total count of 307M pixels.

In operations from 1996 through 1998 VXD3 performed beautifully, yielding a measured single-hit resolution of $\sim 3 \mu\text{m}$, and a track impact-parameter resolution of $8 \mu\text{m}$ ($10 \mu\text{m}$) in $r - \phi$ ($r - z$) respectively, measured using 46 GeV μ tracks in $Z^0 \rightarrow \mu^+\mu^-$ events. The multiple scattering term was $33/p \sin^{3/2}\theta \mu\text{m}$. For inclusive b -hemisphere tagging a sample purity of 98% was obtained with a tag efficiency of over 60%, and for inclusive c -tagging a sample purity of around 80% was obtained with a tag efficiency of about 20%. This performance is ‘state-of-the-art’ today.

*p.burrows@physics.ox.ac.uk

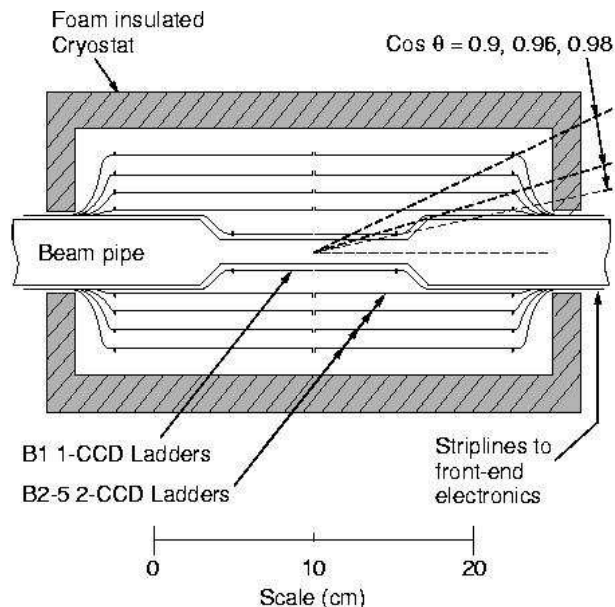

FIG. 1: Schematic of the LC CCD vertex detector.

III. LINEAR COLLIDER PHYSICS DEMANDS

The LC will probably be built to operate at c.m. energies in the range between the LEP2 energy of around 200 GeV and up to 0.8 or 1 TeV. Many of the interesting physics processes can be characterised as multijet final states containing heavy-flavour jets. It should be noted that charm- and τ -tagging, as well as b -tagging, will be very important. For example, measurements of the branching ratios for (the) Higgs boson(s) to decay into b , c , and τ pairs (and/or W , Z^0 and t pairs for a heavy Higgs) will be crucial to map out the mass-dependence of the Higgs coupling and to determine the nature (SM, MSSM, SUGRA ...) of the Higgs particle(s). Because of this multijet structure, even at $\sqrt{s} = 1$ TeV many of these processes will have jet energies in the range $50 \rightarrow 200$ GeV, which is not significantly larger than at SLC, LEP or LEP2. The track momenta will be correspondingly low. For example, at $\sqrt{s} = 500$ GeV the mean track momentum in $e^+e^- \rightarrow q\bar{q}$ events is expected to be around 2 GeV/ c . Hence, for the majority of tracks, multiple scattering in thick detectors will limit the impact-parameter resolution, as was the case even with SLD VXD3, and will compromise the flavour-tagging performance, most seriously for charm and τ .

Furthermore, some of these processes may lie close to the boundary of the accessible phase space, suggesting that extremely high flavour-tagging efficiency will be crucial for identifying a potentially small sample of events above a large multijet combinatorial background. It is worth bearing in mind that a doubling of the single-jet tagging efficiency at high purity is equivalent to a luminosity gain of a factor of 16 for a 4-jet tag; it is likely to be a lot cheaper (and easier) to achieve this gain by building a superior VXD than by increasing the luminosity of the accelerator by over an order of magnitude.

IV. LC VXD R&D PROGRAMME

The LCFI VXD conceptual design is illustrated in Fig. 1. Simulation of the flavour-tagging performance is described elsewhere [4]. Table I summarises the improvement factors that it is hoped to achieve, relative to the current SLD VXD3, for various key parameters; the most challenging are the ladder thickness and readout speed.

A. Ladder Thickness

An aggressive option of ‘unsupported’ silicon is being pursued. In this mode the CCDs would be back-thinned to 50 or 60 μm (0.06% X_0), assembled into a ladder structure, and held under tension at the ends. Although the production of CCDs as thin as 20 μm has been achieved for use in astronomy, the use of such ‘unsupported’ devices has not been tried before, and a number of key issues are being addressed. Of primary concern is the

Item	SLD	LC	factor
longest CCD (mm)	80	125	1.6
largest CCD area (mm ²)	1280	3000	2.3
# ladders	48	64	1.3
# pixels (M)	307	900	2.3
ladder thickness (% X_0)	0.4	0.06	7
pixel readout rate (MHz)	5	50	10
column-parallel r/o	×	√	1000

TABLE I: CCD performance improvement factors required for the LC VXD

degree of mechanical stability achievable. This has both ‘static’ and ‘dynamic’ aspects. We require shape reproducibility at the level of a few microns under temperature cycling between room temperature and about 180K. We also require insensitivity to vibrations, eg. possible flow-driven oscillations caused by the coolant N₂ gas.

A test rig has been assembled and used to investigate the stability of thin prototype ladders comprising two dummy CCDs glued together to form 25cm-long structures. The ladder is pinned to the support jig at one end, and tensioned via a spring mechanism, with a sliding joint to the jig, at the other. Tests have been performed using glass and unprocessed silicon of 60 μm thickness. The results are extremely encouraging. For modest tensions, above 15N, the position reproducibility is better than 3 μm under successive relaxation and reapplication of the tensioning mechanism. The stability under temperature cycling has also been investigated. Here the type of adhesive, the relative CTEs of the glue, ladder and supporting blocks, the pattern of application of the glue, and the alignment of the blocks w.r.t. the ladder are all crucial elements that have been studied using both prototypes and FEA simulations. An optimal solution has been found, which will now be tried with actual thin CCDs.

Metrology apparatus for these stability tests has been set up at RAL and Oxford. The RAL system uses a commercial microscope CMM that is excellent for single-point measurements. The Oxford system is a custom-made white-light interferometer that allows micron-level complete surface profile measurements to be made of ladders as large as $30 \times 2.5 \text{ cm}^2$.

A possible fall-back option is to support the thin CCDs on a thin flat Be beam with an intrinsic ‘omega’ or ‘V’ shape for rigidity. Finite-element analysis simulations have shown that such structures offer the possibility of small, and predictable, deformations under temperature cycling of the order of tens of μm . If the support beam comprises 250 μm Be-equivalent, or 0.07% X_0 , and the adhesive an additional 0.02% X_0 , the CCDs could be fully thinned to 20 μm , yielding a total ladder material budget as low as 0.11% X_0 . The handling and assembly of such thin devices will be addressed if the ‘unsupported’ option proves untenable.

B. Readout Speed

The allowed radial position of the innermost layer w.r.t. the beamline is strongly influenced by the accelerator-related backgrounds, and is correlated with the pixel readout rate, which determines the hit density accumulated during the CCD readout cycle, and hence the degree of fake hit confusion for bona fide tracks. The main sources of accelerator-related backgrounds are: muons from beam interactions with upstream collimators; e^+e^- pairs from converted photons and ‘beamstrahlung’; photoproduced neutrons from the interaction region material and back-shine from the beam dumps; hadrons from beam-gas and $\gamma\gamma$ interactions.

From the VXD occupancy point-of-view the most serious are the e^+e^- pairs. For example, beam-beam interaction simulations indicate that tens of thousands of pairs will be created *per bunch crossing* of the beams. For a VXD layer-1 radius of around 13mm, a large detector solenoidal magnetic field will be required to contain the bulk of the pairs within the beampipe, and maintain an acceptably low hit density. Field strengths of between 3 and 6 T are being considered by the detector working groups. At both NLC (6 T) and TESLA (4 T) roughly 0.03 hits/mm²/bunch crossing are expected in VXD layer 1. This translates to roughly 6 hits/mm²/bunch *train* at NLC, and roughly 90 hits/mm²/bunch *train* at TESLA. Since the pixel density is 2500/mm², a readout that integrates over one complete train is acceptable for NLC, but would yield an uncomfortable 4% occupancy at TESLA. This is not disastrous, but studies show [4] that some pollution of tracks with background hits would result in this crucial layer, closest to the IP.

The requirements are therefore to achieve a complete detector readout between NLC bunch trains, i.e. within about 8ns, and to read out roughly 10 times per train at TESLA, i.e. within about 100 μ s. The NLC goal can be met with a factor of 10 increase in pixel-readout rate relative to what was achieved at SLD, namely 50 MHz. The TESLA goal requires, in addition, parallelisation of the CCD readout; we are investigating the design of a CCD in which every column is read out through an independent output node. This will require the output-node pads and associated readout electronics to be laid out on a pitch of 20 μ m. This is challenging, but preliminary design work for an output circuit on this pitch has been done, and at least one company is able to produce ADCs on the same pitch.

We have outlined a staged approach for developing a column-parallel CCD with the required pixel readout speed, starting at 0.5 MHz, progressing to 5 MHz, and hopefully reaching 50 MHz. The design work, in collaboration with Marconi Applied Technologies, is well advanced. In addition we are bench-testing a standard CCD that has the promise of reaching 70 MHz serial readout speed; this chip has so far been driven at 10 MHz with good signal/noise performance. VME-based drive and readout electronics for 50 MHz operation are under construction at RAL.

C. Radiation Damage Studies

The neutron flux in the inner detector is expected to be at the level of $10^9/\text{cm}^2/\text{year}$. This is about an order of magnitude below the threshold at which a non-negligible charge transfer inefficiency (of order 10^{-4}) results from charge-trapping by damage centres. A number of promising ideas offer the possibility of further headroom. For example, lower-temperature operation may increase the tolerance via trap ‘freezeout’. Trap filling via auxiliary charge injection is another possibility. These ideas warrant further investigation, and low-temperature studies are expected to be performed at the Liverpool test setup.

V. SUMMARY AND OUTLOOK

CCDs offer a very attractive option for a high-energy linear collider vertex detector. CCD VXD’s have been ‘combat-tested’ at the first linear collider, SLC, and have allowed SLD to achieve unrivalled *b* and *c*-jet tagging performance. We are addressing a number of R&D issues to permit successful application of this technology at the LC. There is considerable interest and overlap with other scientific communities, for example astronomy, remote sensing and X-ray imaging.

-
- [1] C.J.S. Damerell et al, IEEE Trans. Nucl. Sci. **33** (1986) 51.
S. Barlag et al, Phys. Lett. **B184** (1987) 283.
 - [2] C.J.S. Damerell et al, Nucl. Instr. Meth. **A288** (1990) 236.
 - [3] K. Abe et al, Nucl. Instr. Meth. **A400** (1997) 287.
 - [4] S. Xella-Hansen, these proceedings.