

Realization of the anomalous scattering method in crystallography on the basis of the parametric X-ray radiation

I.D.Feranchuk and A.P.Ulyanenko

Byelorussian State University, F.Skariny Av., 4, 220050 Minsk, Republic of Belarus

Spectra of parametric X-ray radiation (PXR) are considered in the range of anomalous dispersion for one of the atoms in a crystal elementary cell. The PXR spectra are calculated both for the ultra-relativistic ($E \geq 50MeV$) and non-relativistic ($E \simeq 100KeV$) electrons for the specific conditions corresponding to the organic compounds. It is shown that analysis of the RXR angular distribution permits one to realize the method of anomalous scattering for direct measurement of the phases of structure amplitudes without additional isomorphous intrusion of a heavy atom.

I. INTRODUCTION

Development of the physical methods for direct measurement of the phases of structure amplitudes in the X-ray analysis of the crystals has always attracted a great attention [1]. Solution of the phase problem is especially important for determination of the structure of the complicated organic compounds with elementary cell including a lot of atoms. Quite long ago the effective and simple methods of the direct measurement of phases in the X-ray structure analysis were suggested and realized for some special cases (for example, [2]). The first one is the method of double isomorphous replacement when the heavy atom strongly scattered X-ray radiation is introduced to the investigated structure [3]. Another approach is the anomalous scattering method (ASM) when the intensities of the diffraction reflexes are measured using the radiation with two wave lengths near the absorption edge of one of the atoms in the elementary cell of the analyzed crystal [4]. These methods have big advantage for possible applications in the practical X-ray structure analysis because they permit one to measure the phases in rather thin crystals when the kinematic diffraction theory is available and the observed data can be simply interpreted [5] - [7].

A series of methods for solution of the phase problem were suggested on the basis of the interference phenomena in various variants of the many-beam diffraction. As a rule, the wave interference is essential when the dynamical effects are clearly appeared in the X-ray diffraction and the photons can scatter multiply in the analyzed crystal which should be perfect. Realization of such methods for mosaic and macromolecular crystals is rather complicated problem which is developed actively by many authors at present (for example, [8] - [15] and references therein).

However, the phase information in many-beam diffraction experiments can be extracted from the diffraction data by means of the complicated and precise additional measurements even in the ideal crystal. Therefore elaboration of the effective and universal approach to the experimental realization of ASM is very actual task because in this case only the intensities of reflexes should be measured and they are strictly connected with the structure amplitudes and their phases in the framework of kinematical diffraction. There are two main problems in this way: i) the reflex intensities should be measured with X-rays of various wave lengths and ii) the absorption edge of atoms in the most organic compounds corresponds to very soft X-ray radiation (for example, K_α -line for the sulphur atom S, which is the heaviest atom in the most of aminoacids, corresponds the energy of photons $\hbar\omega_K \simeq 2.40keV$, or wave length $\lambda_K \simeq 5.13\text{\AA}$). It makes difficult to use ASM for the X-ray structure analysis in home laboratories because of lack of the soft X-ray sources with smoothly variable wave length. Possibly, these problems could be overcome by means of synchrotron radiation but even in this case some difficulties are appeared when choosing the crystal-monochromator for soft X-rays [16].

In the present paper we discuss another possibility to use ASM for the structure analysis of organic compounds by means of measurement of angular distribution of PXR generated by electrons passing through the investigated crystal [17]. There are two variants in order to realize such approach in laboratory conditions. One of them can be built on the basis of PXR from ultrarelativistic electrons (with the energy $E \sim 30 - 50MeV$), when the investigated crystal is arranged inside the betatron. This type of PXR was successfully obtained recently by authors of [18]. In Sec.2 we will discuss the realization of ASM in scope of such approach.

The other method (Sec.3) is based on PXR from the nonrelativistic electrons (with the energy $E \sim 100keV$). The main characteristics and some applications of such form of PXR were considered in our papers [19]-[22].

II. ASM ON THE BASIS OF PXR FROM ULTRARELATIVISTIC ELECTRONS

Remind some qualitative features of the interaction of the ultrarelativistic electrons with crystals which permit one to consider the PXR kinematics and most essential for preliminary analysis of the phenomenon [23],[24]. Let us

suppose that an electron with energy $E \gg mc^2$ (m is the electron mass; c is the light velocity) enters the crystal with an arbitrary orientation relatively to the electron velocity \vec{v} (Fig.1). It is well known that the charge particle's electromagnetic field can be represented as the pseudophoton beam [23], whose properties are closed to those of real photons with the wave vectors $\vec{k} = \omega\vec{v}/c^2$, concentrated in the angular cone $\Delta\theta \simeq mc^2/E$ along the vector \vec{v} and the spectral density $n(\omega)$ that is defined by the following formula [23]:

$$n(\omega)d\omega \simeq \frac{\alpha}{\pi\omega} \ln\left(\eta\frac{E}{\hbar\omega}\right)d\omega, \quad (1)$$

where $\alpha = \frac{e^2}{\hbar c} \simeq \frac{1}{137}$ is the fine structure constant and η is the the value of the order of unity.

Рис. 1: Sketch of the PXR experiment

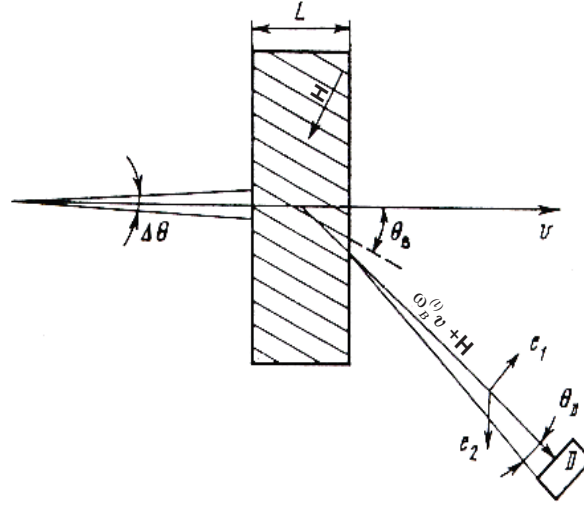

From this point of view the kinematics of the electromagnetic interaction between the electron and crystal is equivalent to the interaction of the photon beam with the angle divergence $\Delta\theta$ and the "white" spectrum (1) with the same crystal. In particular, the photons with the wave vector satisfied to the Bragg condition with one of vector \vec{H} of the reciprocal lattice of the crystal

$$(\vec{k} + \vec{H})^2 \simeq k^2; \quad 2\omega(\vec{v}\vec{H}) + H^2c^2 \simeq 0, \quad (2)$$

will be reflected by the corresponding crystallographic planes. It will lead to the appearance of the X-ray radiation peak (reflex) over the angle $2\theta_B$ with respect to the electron velocity. The value θ_B is defined by the angle between the reflected planes and the vector \vec{v} (Fig.1), that is

$$(\vec{v}\vec{H}) = -vH \sin \theta_B.$$

The totality of such reflexes conditioned by various crystallographic planes and distributed in the space represents the integral spectrum of PXR from the ultrarelativistic electrons [24]. Intensity of the radiation in the every reflex is defined by the same structure amplitude $F(\vec{H})$ as for scattering of the real photons in the same direction. Besides, each reflex has the "fine structure" that is characteristic angular and frequency distributions [24] correspondingly near the angle $2\theta_B$ and frequency ω_B (wave length λ_B), which value can be found strictly from the formula (2)

$$\omega_B = \frac{Hc^2}{2v \sin \theta_B}; \quad \lambda_B = \frac{4\pi v \sin \theta_B}{Hc}. \quad (3)$$

These properties of the PXR spectrum were confirmed by a lot of experiments (for example, [25] and references therein) and their results in a good agreement with the theory.

In accordance with the formula (3) the radiation frequency in the PXR reflex can be varied by simple rotation of the crystal relatively to the electron beam and it is the basis for development of new sources of the monochromatic X-ray radiation with smoothly changeable frequency [18], [19]. But the main purpose of the present paper is the justification of the possibility to use this property of PXR for solution of another problem which is the direct measurement of the phase of structure amplitudes $F(\vec{H})$ on the basis of ASM. It means that the incident angle of the electron in the crystal should be chosen such a way that the radiation frequency in the PXR reflex from the analyzed plane was near the frequency of absorption K-edge ω_K of one of the substances forming the crystal

$$\sin \theta_K^H = \frac{Hc^2}{2v\omega_K} = \frac{c}{4\pi v} H\lambda_K, \quad (4)$$

where λ_K is the wave length of K_α -line for the considered substance .

Analogous approach was also discussed before in our paper [26]. But this analysis was referred to the case of X-rays corresponding to the characteristic frequencies of the heavy atoms and, besides, was considered for the conditions of the dynamical diffraction in the perfect crystals. But both conditions are not realized in the organic compound crystals considered in the present paper.

It is important to notice that the characteristic parameters which define the interaction of the X-rays with the organic crystals are essentially differed from the analogous values for inorganic crystals. In particular the former ones have a comparatively small susceptibility χ_0 and a quite large extinction length L_e which is the same order as the investigated sample size L . In its turn, the value L is usually smaller than the absorption length L_{abs} . In order to estimate these parameters and consider the quantitative analysis of the effect let us choose for definiteness one of the typical organic crystals which structure was recently investigated in the paper [27]. This is the crystal of the dimetil-ether of the 4-fenilsemicarboacetil acid (DFA) with the structure formula

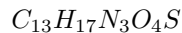

It has the monoclinic singony and space group $P2_1/n$. The elementary cell parameters (a,b,c), its volume Ω and the directing angle β have the following values accordingly

$$a = 8.066, b = 15.812, c = 24.977A; \quad \Omega = 3174A^3; \quad \beta = 94.88. \quad (5)$$

Accordingly to the formula (3) for the crystals with such values of the lattice parameters the wave length of the most part of the PXR reflexes belongs to the range of $\lambda \leq 20A$. The only atom of the sulphur S has the absorption edge in this range and we will consider it as the main object for realization of ASM. One more reason for choice just S for this purpose is its universal spreading almost in all organic crystals and its coordinate is found most precisely on the first stadium of the structure analysis because of rather big charge [5].

Let us calculate the susceptibility χ_0 [28] of the considered crystal with the total number of electrons in the elementary cell $Z_{tot} = 164$ and for the wave length $\lambda_K \simeq 5.13A$, corresponding the K-edge of the atoms S

$$\chi_0 = -\frac{e^2 Z_{tot} \lambda_K^2}{4\pi^2 m c^2 \Omega} \quad a = 8.066, b = 15.812, c = 24.977A; \quad \Omega = 3174A^3; \quad \beta = 94.88. \quad (6)$$

Then the unknown values are

$$\chi_0 \simeq -1.2310^{-5}; \quad L_e = \frac{\lambda_K}{\pi|\chi_0|} \simeq 13.3\mu k; \quad L_{abs} \simeq 1mm. \quad (7)$$

These values can be compared with the analogous ones for the crystal Si which has the susceptibility $\chi_0 \simeq 1.510^{-4}$ for the same wave length and essentially less extinction length.

Besides, the average effective charge Z_{eff} for one atom is rather small for the organic crystals (for the DFA crystal $Z_{eff} = 4$), and multiple scattering in these materials is essentially less than in the inorganic crystals.

III. CALCULATION OF THE PHASES OF THE STRUCTURE AMPLITUDES

It can be shown that for the above mentioned parameters of the organic crystals intensity of the PXR reflex can be calculated in the scope of the kinematical approximation when it is defined by means of the following simple formula

$$I_{\vec{H},\omega} = A(E)|F(\vec{H},\omega)|^2, \quad (8)$$

where the value $A(E)$ is the universal coefficient which depends on the particle energy but doesn't connect with the crystal structure [24].

So, one can measure the value $|F(\vec{H},\omega)|$ strictly from the intensity measurements

$$|F(\vec{H},\omega)| = \sqrt{\frac{I_{\vec{H},\omega}}{A(E)}}. \quad (9)$$

From the other side, in the of the anomalous dispersion this value can be expressed as follows

$$|F(\vec{H},\omega)|^2 = |F_0(\vec{H}) + [\Delta f'(\omega) + i\Delta f''(\omega)]S(\vec{H})|^2, \quad (10)$$

where $F_0(\vec{H},\omega)$ is the value of the crystal structure amplitude calculated with the wave length far from the range of the anomalous dispersion; $\Delta f'(\omega), \Delta f''(\omega)$ are the anomalous corrections to the atom amplitude which are essential in the range $\omega \simeq \omega_K$ and their values are well known [2] ; $S(\vec{H},\omega)$ is the structure factor of the sulphur atoms in the elementary cell.

The relative interval of the anomalous dispersion $\Delta\omega_K/\omega_K$ is the value of the order of unit [2] and it is essentially wider than the characteristic frequency interval $\Delta\omega_B/\omega_B \simeq mc^2/E \ll 1$ for the PXR reflex. So, one can measure the values $F_{1,2}(\vec{H},\omega_{1,2})$ for two different frequencies in the interval of the anomalous dispersion. From the other side, one can also use the reflex corresponding to the reciprocal lattice vector ($\vec{H} = -\vec{H}$), as it is usually considered in the ASM. This reflex can be measured in the result of the rotation of the crystal on the 180° around the axis perpendicular to the electron velocity and with the same value $A(E)$. In this case the structure amplitude is defined by the equation

$$|F(\vec{H},\omega)|^2 = |F_0^*(\vec{H}) + [\Delta f'(\omega) + i\Delta f''(\omega)]S^*(\vec{H})|^2. \quad (11)$$

This value can also be measured for the same frequencies $\omega_{1,2}$. In the result 4 equations will be obtained for 2 unknown values $F_0(\vec{H}), S(\vec{H})$ and their phases which can be uniquely calculated.

IV. CONCLUSIONS

So, the method of the direct measurement of the phases of the structure amplitudes on the basis of the parametric X-ray radiation in the range of the anomalous dispersion is justified theoretically.

V. ACKNOWLEDGMENTS

Authors are grateful to the International Scientific Technical Center (Grants B-626) for the support of this work.

-
- [1] M.M.Woolfson and H.F.Fan, *Physical and Non-physical Methods of Solving Crystal Structures*, (Cambridge, England, 1995).
 - [2] B.K.Vainshtein, *Modern Crystallography*, v.1, ("Nauka", Moscow, 1978).
 - [3] D.Harker, *Acta Cryst.*, **9**,(1956), 1.
 - [4] J.M.Bijvoet, *Nature*, **173**,(1954), 888.
 - [5] Porai-Koshitz, *Practical Course of the X-ray structure analysis*, v.2, ("Fizmatgiz", Moscow, 1968).
 - [6] W.A.Hendrickson, *Science*, **254**,(1991), 51.
 - [7] J.P.Attfield, *Nature (London)*, **343**,(1990), 46.
 - [8] M.Hart and A.R.Lang, *Phys. Rev. Lett.*, **7**,(1961), 120.
 - [9] R.Collela, *Acta Crystallogr.*, **A 30**,(1974), 413.
 - [10] B.Post, *Phys. Rev. Lett.*, **39**,(1977), 760.
 - [11] S.L.Chang, *Multiple Diffraction of X-rays in Crystals*, (Springer-Verlag, Heidelberg, 1984).

- [12] E.Weckert and K. Hümmer, *Acta Crystallogr.* , **A 53**,(1997), 108.
- [13] Q.Shen and R.Collela,*Nature (London)*, **329**,(1987), 232.
- [14] Q.Shen and X-R. Huang,*Phys. Rev. B*, **63**,(2001), 174102.
- [15] Y.P.Stetsko, G-Y.Lin, Y-S.Huang and S-L.Chang, *Phys. Rev. Lett.*,**86**,(2001), 2026.
- [16] M.Hart , *Nucl. Instrum. Methods*, **A 297**,(1990), 306.
- [17] Baryshevsky V.G, Danilov V.A., Feranchuk I.D. and Shadyro L.L., *USSR patent*, **1032376**,(priority 01.04.1983).
- [18] V.V.Kaplin, S.R.Uglov, O.F.Bulaev, V.J.Goncharov, A.A.Voronin, M.A.Piestrup, C.K.Gary, N.N.Nasonov and M.K.Fuler, *Appl. Phys. Letters*, **80**,(2002), 3427.
- [19] I.D.Feranchuk and A.P.Ulyanenko, *Acta Crystallogr.* , **A 55**,(1999), 466.
- [20] I.D.Feranchuk, A.P.Ulyanenko, J.Harada and J.C.H. Spence, *Phys. Rev. E* , **62**,(2000), 4225.
- [21] I.D.Feranchuk and A.P.Ulyanenko, *Phys. Rev. B* , **63**,(2001), 155318.
- [22] I.D.Feranchuk and A.P.Ulyanenko, *Acta Crystallogr.* , **A 57**,(2001), 283.
- [23] V.G.Baryshevskii and I.D.Feranchuk *J. of Phys. (Paris)* , **44**,(1983), 913 .
- [24] I.D.Feranchuk and A.V.Ivashin, *J. of Phys. (Paris)* , **46**,(1985), 1981.
- [25] K.-H.Brenzinger, B.Limburg, H.Backe et al., *Phys.Rev.Lett.*, **79**,(1997), 1997.
- [26] I.D.Feranchuk and A.V.Ivashin, *Crystallography*, **34**,(1989), 39.
- [27] V.X.Kravtsov, Yu.A.Simonov, Ya.Lipkovsky et al., *Crystallography*, **47**,(2002), 87.
- [28] R.W.James, *The Optical Principles of the Diffraction of X-rays*, (G.Bell and Sons Ltd., London, 1960).
- [29] F.N.Allen and O.Kennard , *Chem. Dedign Automat. News*, **8**,(1993), 131.