

Spin Dependent Transport in Magnetic Nanostructures

S. Maekawa

Institute for Materials Research, Tohoku University, Sendai 980-8577, Japan

Abstract

Recent progress in physics on spin dependent transport in magnetic nanostructures is reviewed. Special attention is paid on the spin accumulation and spin current caused by spin injection into non-magnetic metals and semiconductors and superconductors. A variety of phenomena induced in nano-superconductor/ferromagnet devices are proposed, examining the spin-charge separation in superconductors.

Key words: spin polarized transport, spin injection, spin accumulation, spin current, tunneling

PACS: 72.25Ba, 72.25.Hg, 72.25.Mk, 73.40.Gk

1. Introduction

Discovery in 1988 of the so-called giant magnetoresistance (GMR) effect in magnetic multilayers [1,2] raised the curtain for an intensive new research effort on magnetic materials and magnetic thin films which profited enormously from the application of microfabrication techniques [3]. Semiconductor devices have been the main actors on the electronics stage during the latter half of twentieth century. The size of such devices has been getting steadily smaller following the impressive progress in microfabrication techniques. In addition, the physics of such small semiconductor devices, i.e., mesoscopic physics, has emerged as a subject of study in its own right. It is also relevant to remember the considerable quantity of new physics which has emerged since the discovery of high temperature superconductors in 1986. In this latter field, one of the main concerns is the behavior of spin and charge and their interac-

tions. On the other hand, to date in semiconductor devices only the movement of charge has found application with spin being usually considered as an irrelevant degree of freedom. The discovery of GMR signaled a starting point for the physics and application of the interaction between spin and charge and shed light to the spin polarized tunneling [4,5] which was studied in advance of GMR. Here, I would like to review the new physics of spin dependent transport in magnetic nanostructures. Special attention is paid on the spin accumulation and spin current caused by spin injection into non-magnetic metals and semiconductors and superconductors. Examining the spin-charge separation in superconductors [6], a variety of phenomena induced in nano-superconductor/ferromagnet devices are proposed.

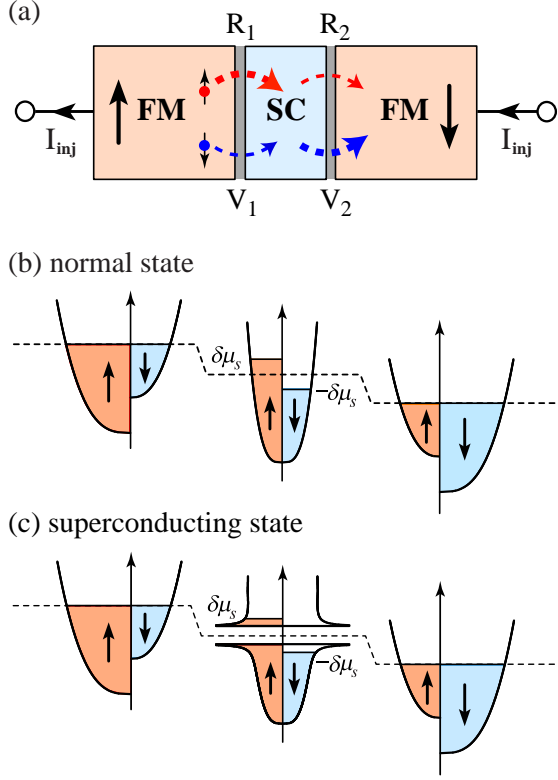

Fig. 1. (a) Double tunnel junction comprising two ferromagnets (FM) and a superconductor (SC) separated by insulating barriers. R_1 and R_2 are the tunnel resistances of the left and right junctions with the voltage drops, V_1 and V_2 , across the barriers ($V = V_1 + V_2$ is the total voltage drop across the entire double tunnel junction). Schematic diagram of the densities of states of FMs (left and right) and SC (middle) in the antiparallel alignment of magnetizations of FMs are shown when SC is in the normal state (b) and in the superconducting state (c). $\delta\mu_s$ denotes the shift in the chemical potentials of the spin subbands.

2. Spin Accumulation

Let us consider a double tunnel junction device shown in Fig. 1 (a), where two ferromagnetic electrodes and a non-magnetic island are separated by two tunnel barriers. In the device, the magnetic moments of two ferromagnetic electrodes are taken to be antiparallel and the electric current is introduced from the left electrode. In Fig. 1(b), the schematic electronic structure is presented. Here, electrons with up spin mainly come into the central island from the left electrode, whereas elec-

trons with down spin mainly go out from the island to the right. As a result, the spin imbalance occurs in the island with size smaller than the spin diffusion length (l_s), when electrons pass through it within the time less than the spin relaxation time (τ_s). Since the magnetization is given by the difference between the numbers of electrons with up and down spins times the Bohr magneton (μ_B), the island is magnetized by the electric current. This is called spin accumulation. Spin accumulation causes the tunnel magnetoresistance (TMR) [7,8,9,10,11,12]. In a double tunnel junction device with two equivalent ferromagnetic electrodes, the spin polarization being P , and two equal tunnel barriers, the TMR is given by

$$TMR = P^2/(1 - P^2), \quad (1)$$

which is a half of that in the usual ferromagnetic tunnel junctions, i.e., $TMR = 2P^2/(1 - P^2)$ [4,5,13,14,15,16]. Therefore, the spin accumulation may be examined by using TMR. Recently, the TMR due to the spin accumulation has been studied in GaMnAs/GaAs/GaMnAs double tunnel junction devices [12]. When the central island in Fig. 1 (a) becomes superconducting, the competition between spin accumulation and superconductivity occurs as depicted in Fig. 1 (c). In the superconducting state, there appears the superconducting gap (Δ), which competes with the spin accumulation. In Fig. 2 (a), the theoretical results of the shift of the Fermi level ($\delta\mu_s$) due to spin accumulation and Δ are presented as functions of bias voltage (V) in the double tunnel junction device where the magnetic moments in the electrodes are antiparallel. When the bias voltage becomes of the order of the gap, $eV/2 \sim \Delta/P$, the superconductivity is suppressed [10]. In Fig. 2 (b), the tunnel conductances, G_{AP} and G_P , are shown in the device with antiparallel and parallel magnetic moments, respectively. For the antiparallel magnetic moments, the superconductivity is suppressed at $V = V_c$ and the conductance jumps. The TMR in the device is given in Fig. 2 (c), where the dashed line shows the value given by Eq. (1). We note that the TMR oscillates as a function of V since Δ depends on spin accumulation [17,18,19]. The suppression of the superconducting gap by

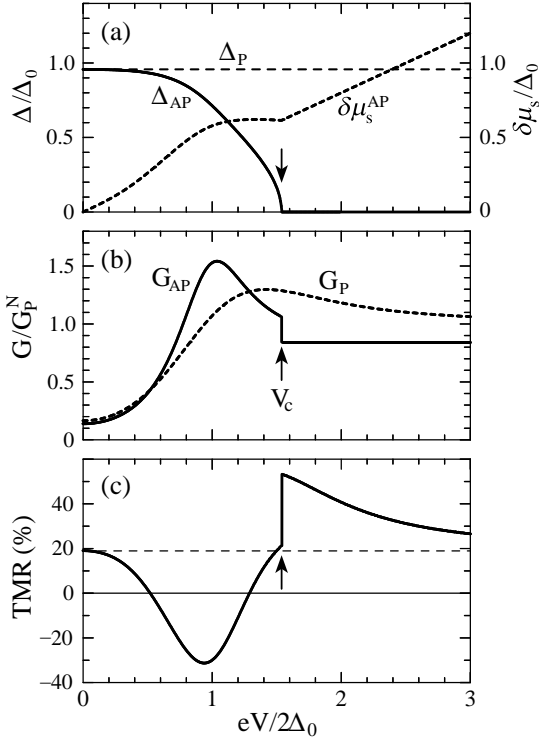

Fig. 2. (a) Superconducting gaps, Δ_P and Δ_{AP} , for the parallel (P) and antiparallel (AP) alignments of magnetizations, respectively, and the half of the spin splitting between the spin-up and spin-down bands in the AP alignment, $\delta\mu_s^{AP}$. (b) Tunnel conductances, G_P and G_{AP} , for the P and AP alignments, respectively. (c) Tunnel magnetoresistance (TMR). Thin dashed line indicates $\text{TMR} = P^2/(1 - P^2)$ in the normal state. The values $P = 0.4$ and $T/T_c = 0.5$ are taken for all curves.

spin accumulation may be observed by the superconducting critical current, J_c , following the relation, $J_c \propto \Delta^3$ [10,20,21,22,23,24]. In Fig. 3, J_c normalized by that at zero temperature, J_{c0} , is plotted as a function of the injected current, I_{inj} , at $T/T_c = 0.9$, the temperature (T) being normalized by the critical temperature (T_c). Here, the spin polarization of one of the ferromagnetic electrodes is taken to be $P_1 = 0.8$ and that of the other one is chosen to be the values, $P_2 = 0, 0.4$ and 0.8 . The tunnel resistance of the both tunnel barriers is equal and is taken to be R_T . For the tunnel device with the same ferromagnetic electrodes ($P_1 = P_2$), the superconductivity is strongly suppressed for the antiparallel magnetic

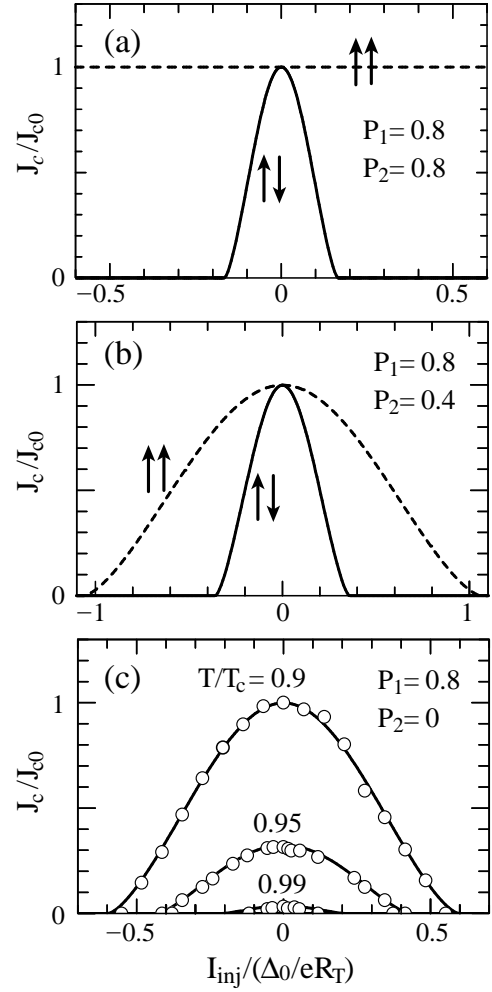

Fig. 3. Critical current J_c as a function of injection current I_{inj} for the spin polarizations P_1 of FM1 and different values of P_2 of FM2 at $T/T_c = 0.9$: (a) $P_1 = 0.8$ and $P_2 = 0.8$, (b) $P_1 = 0.8$ and $P_2 = 0.4$, and (c) $P_1 = 0.8$ and $P_2 = 0$. Open circles indicate the critical current at $T = 80$ K, 84 K and 87 K ($T_c \sim 89$ K) in $\text{Au}/\text{YBa}_2\text{Cu}_3\text{O}_7/\text{LaAlO}_3/\text{Nd}_{2/3}\text{Sr}_{1/3}\text{MnO}_3$ junctions [21].

moments, whereas it is not for the parallel moments as seen in Fig. 3 (a). On the other hand, for the device with different ferromagnets ($P_1 \neq P_2$), the superconductivity is suppressed even for the parallel moments since spins coming into and going out from the island is not equal (Fig. 3 (b)). When one of the electrodes is non-magnetic, P_2 is equal to zero (Fig. 3 (c)). The experimental result

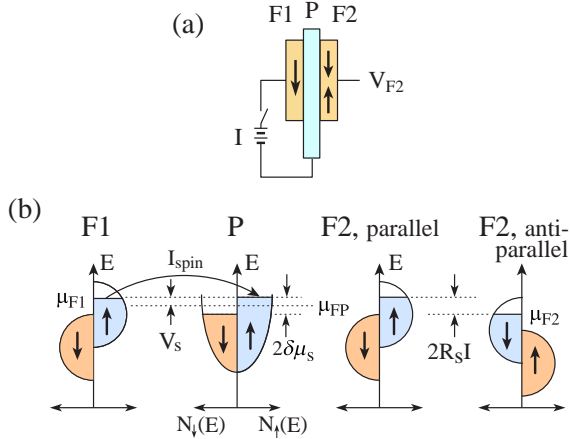

Fig. 4. (a) Three terminal device introduced by Johnson [26]. Arrows in F1 and F2 refer to the magnetization orientation. (b) Diagram of the densities of states of the ferromagnet(F1)/paramagnet(P)/ferromagnet(F2) system in (a).

obtained in $\text{Nd}_{1-x}\text{Sr}_x\text{MnO}_3/\text{YBa}_2\text{Cu}_3\text{O}_7/\text{Au}$ devices [21] and theoretical ones are shown by circles and solid lines, respectively, in Fig. 3 (c), where $\text{Nd}_{1-x}\text{Sr}_x\text{MnO}_3$ is a ferromagnetic electrode and $\text{YBa}_2\text{Cu}_3\text{O}_7$ is a high temperature superconductor with $T_c = 89$ K. As noted above, the shift of the Fermi level ($\delta\mu_s$) due to spin accumulation competes with the superconductivity, which disappears at $V_c \sim 2\Delta/eP$. It is also known that the superconductivity is suppressed by an applied magnetic field (Pauli paramagnetic effect). In this case, the critical field is given by $H_c \sim 2\Delta/\mu_B$. By comparing these two effects, we find that the bias voltage of 0.1V corresponds to the magnetic fields of the order of 10^2 T for superconductivity. It is very hard to suppress the high temperature superconductivity by an applied magnetic field, since it is too large to access it in the usual experimental conditions. On the other hand, the bias voltage of the order of 0.1V may be obtained easily. This fact suggests potentials for application of spin accumulation in various fields.

3. Spin Injection Devices

Johnson and Silsbee in 1985 [25] and Johnson in 1993 [26] have proposed a three-terminal de-

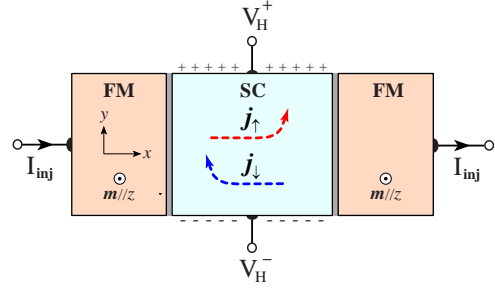

Fig. 5. Spin injection device of a double tunnel junction FM/SC/FM in the parallel magnetic moments of FMs, in which a nonequilibrium Hall voltage V_H is induced in the transverse direction by injection of spin-polarized current.

vice shown in Fig. 4 (a), which consists of a non-magnetic metal (P) and two ferromagnets (F1 and F2). Let us consider that both F1 and F2 are half-metallic, for simplicity. Then, electrons with up spin are injected from F1 into P as seen in Fig. 4 (b). As a result, the Fermi level with up spin in P is different from that with down spin. Therefore, the voltage (V_2) depends on whether the magnetic moment of F2 is parallel or antiparallel to that of F1 [27,28,29,30]. Recently, well-defined three-terminal devices were prepared by using the microfabrication technique [31,32]. Here, it is important that the size of the devices is smaller than the spin diffusion length (l_s), which is less than $1 \mu\text{m}$ in the usual non-magnetic metals. Since the signal in such spin injection devices is obtained as the voltage induced by the electric current, a low-carrier material in the nonmagnetic part will provide an opportunity for obtaining the larger signal. Therefore, semiconductors such as GaAs with long spin diffusion length may be good candidates in the devices [33,34,35,36]. We note that superconductors are low-carrier systems for spin, since spin is carried by quasi-particles whereas charge is by Cooper pairs. Thus, the large spin injection signal is also expected in the devices with superconductors [33].

4. Anomalous Hall Effect

Anomalous Hall effect in a ferromagnet is caused by spin polarized current scattered by the spin-orbit interaction at impurities [37,38,39,40]. In

other words, spin current shifts to charge current perpendicular to the applied bias voltage by the scattering [37]. Let us consider a double tunnel junction device in Fig. 5, where two electrodes are made of the same ferromagnet with magnetic moments perpendicular to the film plane (z -direction). The current (I_{inj}) is injected from the left electrode to the non-magnetic central one (x -direction). In this case, the charge and spin currents, respectively, are expressed as

$$I_{charge} = I_{\uparrow} + I_{\downarrow}, \quad (2)$$

$$I_{spin} = I_{\uparrow} - I_{\downarrow} = PI_{inj}, \quad (3)$$

where I_{\uparrow} and I_{\downarrow} are the current with spin up and down, respectively, and P is the spin polarization in the ferromagnetic electrodes. The Hall current is induced perpendicular to the injected current (y -direction) and the Hall voltage is given by

$$V_H \propto \vec{z} \times \vec{I}_{spin} = \vec{z} \times P \vec{I}_{inj}. \quad (4)$$

It is interesting to see the Hall voltage in the superconducting state. As mentioned in the previous section, the charge current is carried by Cooper pairs and is not affected by impurities. Since impurity scattering occurs only for quasi-particles which carry spin current, the Hall effect in superconductors proves that the anomalous Hall effect is due to spin current but not charge [40].

5. Conclusion

Recent progress in microfabrication techniques has brought spin-electronics devices of the order of or smaller than the spin diffusion length (l_s) [41], which provide a variety of spin dependent phenomena due to spin accumulation and spin current. The phenomena also depend on the geometry of the devices. Spin dependent transport in magnetic nanostructures is based on the physics of the interaction between spin and charge. In this sense, the spin-charge separation of electrons is a starting point for the physics of spin-electronics.

Acknowledgements:

I would like to thank S. Takahashi, H. Imamura, T. Yamashita and J. Martinek for continuous collaboration in this field. This work has been supported by a Grant-in-Aid for Scientific Research from MEXT and CREST.

References

- [1] M. N. Baibich *et al.*, Phys. Rev. Lett. **61** (1988) 2472.
- [2] G. Binash *et al.*, Phys. Rev. B **39** (1989) 4828.
- [3] *Spin Dependent Transport in Magnetic Nanostructures*, edited by S. Maekawa and T. Shinjo (Taylor and Francis, London and New York, 2002).
- [4] M. Julliere, Phys. Lett. **54A** (1975) 225.
- [5] S. Maekawa and U. Gafvert, IEEE Trans. Magn. **18** (1982) 707.
- [6] J.R. Schrieffer and M. Tinkham Rev. Mod. Phys. **71** (1999) 313.
- [7] J. Barnas and A. Fert, EuroPhys. Lett., **44** (1998) 85.
- [8] A. Brataas, Y.V. Nazarov, J. Inoue, and G.E.W. Bauer, Phys. Rev. B **59** (1999) 93.
- [9] H. Imamura, S. Takahashi, and S. Maekawa, Phys. Rev. B **59** (1999) 6017.
- [10] S. Takahashi, H. Imamura, and S. Maekawa, Phys. Rev. Lett. **82**, 3911 (1999); *ibid.*, J. Appl. Phys. **87**, 5227 (2000).
- [11] J. Martinek, J. Barnas, A. Fert, S. Maekawa, and G. Schon J. Appl. Phys. **93** (2003) 8265.
- [12] R. Mattana *et al.*, Phys. Rev. Lett. **90** (2003) 166601.
- [13] J.S. Moodera *et al.*, Phys. Rev. Lett. **74** (1995) 3273.
- [14] T. Miyazaki and N. Tezuka, J. Magn. Magn. Mater. **139**, L231(1995).
- [15] J. C. Slonczewski, Phys. Rev. B **39**, 6995 (1989).
- [16] S. S. P. Parkin *et al.*, J. Appl. Phys. **85** (1999) 5828.
- [17] T. Miyazaki (private communication).
- [18] J. Johansson *et al.*, J. Appl. Phys. **93** (2003) 8650.
- [19] T. Ono (private communication).
- [20] V.A. Vas'ko *et al.*, Phys. Rev. Lett. **78** (1997) 1134.
- [21] Z.W. Dong *et al.*, Appl. Phys. Lett. **71** (1997) 1718.
- [22] N.-C. Yeh *et al.*, Phys. Rev. B **60** (1999) 10522.
- [23] J.Z. Liu *et al.*, *Physica C* **357-360** (2001) 1614.
- [24] C.D. Chen *et al.*, Phys. Rev. Lett. **88** (2002) 047004
- [25] M. Johnson and R.H. Silsbee, Phys. Rev. Lett. **55** (1985) 1790; *ibid.* **60** (1988) 377.

- [26] M. Johnson, Phys. Rev. Lett. **70** (1993) 2142.
- [27] T. Valet and A. Fert, Phys. Rev. B **48** (1993) 7099.
- [28] A. Fert and S.F. Lee, Phys. Rev. B **53** (1996) 6554.
- [29] S. Hershfield and H.L. Zhao, Phys. Rev. B **56** (1997) 3296.
- [30] M. Johnson and J. Byers, Phys. Rev. B **67**, 125112 (2003).
- [31] F.J. Jedema *et al.*, Nature (London) **410** (2001) 345; **416**, 713 (2002); Phys. Rev. B **67** (2003) 085319.
- [32] J.-M. George, A. Fert, and G. Faini, Phys. Rev. B **67** (2003) 012410.
- [33] S. Takahashi and S. Maekawa, Phys. Rev. B **67** (2003) 052409.
- [34] A. Fert and H. Jaffrès, Phys. Rev. B **64** (2001) 184420.
- [35] E.I. Rashba, Phys. Rev. B **62** (2000) R16267.
- [36] G. Schmidt *et al.*, Phys. Rev. B **62** (2000) R4790.
- [37] J.E. Hirsch, Phys. Rev. Lett. **83** (1999) 1834.
- [38] S. Zhang, Phys. Rev. Lett. **85** (2000) 393.
- [39] Y. Otani *et al.*, J. Magn. Magn. Mater. **239**, 135 (2002).
- [40] S. Takahashi and S. Maekawa, Phys. Rev. Lett. **88** (2002) 116601.
- [41] T. Yamashita, H. Imamura, S. Takahashi, and S. Maekawa, Phys. Rev. B **65** (2002) 172509.