

Performance of cryogenic microbolometers and calorimeters with on-chip coolers

D. V. Anghel,^{a,b} A. Luukanen,^{a,c} and J. P. Pekola^a

^aUniversity of Jyväskylä, Department of Physics, P.O. Box 35, FIN-40351, Jyväskylä, Finland

^bNIPNE – “HH”, P.O.Box MG-6, R.O.-76900 București - Măgurele, Romania

^cMetorex International Oy P.O. Box 85, FIN-02631, Espoo, Finland

Astronomical observations of cosmic sources in the far-infrared and X-ray bands require extreme sensitivity. The most sensitive detectors are cryogenic bolometers and calorimeters operating typically at about 100 mK. The last stage of cooling (from 300 mK to 100 mK) often poses significant difficulties in space-borne experiments, both in system complexity and reliability. We address the possibility of using refrigeration based on normal metal/insulator/superconductor (NIS) tunnel junctions as the last stage cooler for cryogenic thermal detectors. We compare two possible schemes: the direct cooling of the electron gas of the detector with the aid of NIS tunnel junctions and the indirect cooling method, when the detector lattice is cooled by the refrigerating system, while the electron gas temperature is decreased by electron-phonon interaction. The latter method is found to allow at least an order of magnitude improvement in detector noise equivalent power, when compared to the direct electron cooling.

A thermal detector system, such as a bolometer or a calorimeter, consists of a thermal sensing element (TSE) which is connected to a heat sink. The TSE typically consists of an absorber and a thermometer. The thermometer can be a transition-edge sensor [1–3], or a normal metal/insulator/superconductor NIS tunnel junction thermometer [4,5]. In this paper we address the fundamental question of whether one should cool the electrons of the detector directly, i.e. cool the TSE below the heat sink temperature, or alternatively cool the heat bath of the TSE. The principle of the NIS cooler has been introduced in Refs. [6] and [7].

The sensitivity of thermal detectors is strongly influenced by the detector temperature. The figure of merit for bolometric detectors is the noise equivalent power (NEP). To calculate this quantity for thermal detectors coupled to on-chip coolers, we have to evaluate the fluctuations of the electron gas temperature due to the power exchange with the lattice, with the superconductor of the cooler (in the case of direct cooling), and due to the bias of the thermometer (see Fig. 1). We can then define the NEP as the optical input power (the power to be detected) needed to produce a change in the temperature of the electron gas equal to the square root of the mean square of these fluctuations. In the following calculations the noise introduced by the bias power \dot{Q}_b is supposed to be very small.

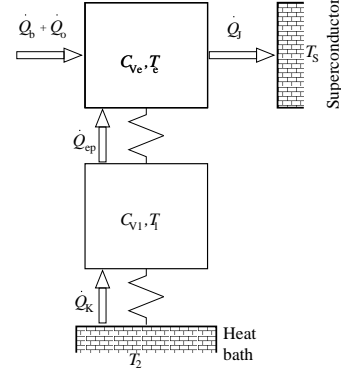

FIG. 1. The schematic drawing of the thermal sensing element. The two rectangular boxes represent two distinct subsystems of this element: the electron system and the lattice. The electron system, the lattice, the heat bath, and the superconductor are at the temperatures T_e , T_1 , T_2 , and T_s , respectively. In the case of direct cooling the superconductor is connected with the electron gas through NIS junctions, while in the case of indirect cooling it is used to cool down the thermal bath. The heat capacities of the electron gas and the lattice are C_{Ve} and C_{Vl} , respectively. The power fluxes transmitted between the systems are represented in the figure by long arrows and are denoted by \dot{Q}_J , \dot{Q}_{ep} , \dot{Q}_K . \dot{Q}_b is the bias power, while \dot{Q}_o is the optical input power to be detected.

Applying the prescription above and making use of the power balance equation for the TSE, schematically drawn in Fig. 1, we arrive at the following expression for the NEP [8]:

$$\begin{aligned}
 \text{NEP}^2 = & \langle \delta^2 \dot{Q}_{ep, \text{shot}}(\omega) \rangle \left| 1 + \frac{\partial \dot{Q}_{ep}}{\partial T_1} \frac{1}{i\omega C_{V1} + \frac{\partial(\dot{Q}_{ep} - \dot{Q}_K)}{\partial T_1}} \right|^2 \\
 & + \langle \delta^2 \dot{Q}_{K, \text{shot}}(\omega) \rangle \left(\frac{\partial \dot{Q}_{ep}}{\partial T_1} \right)^2 \\
 & \times \frac{1}{\omega^2 C_{V1}^2 + \left[\frac{\partial(\dot{Q}_{ep} - \dot{Q}_K)}{\partial T_1} \right]^2} + \langle \delta^2 \dot{Q}_{J, \text{shot}}(\omega) \rangle \\
 & + \frac{1}{\omega^2} \left(\frac{\partial \epsilon_F}{\partial N} \frac{\partial \dot{Q}_J}{\partial E} \right)^2 \langle \delta^2 \dot{N}_{J, \text{shot}}(\omega) \rangle,
 \end{aligned} \tag{1}$$

where $E = eV$ (V is the voltage across the junction), while $\delta \dot{Q}_{(J/ep/K), \text{shot}}(\omega)$ and $\delta \dot{N}_{J, \text{shot}}(\omega)$ are the ω com-

ponents of the Fourier transformed *shot noise fluctuations* (finite quantities transferred randomly at a *constant* average rate) of the power fluxes $\dot{Q}_{(J/ep/K)}$ and particle flux \dot{N}_J (through the NIS junctions), respectively. The other notations are explained in Fig. 1. We can now observe that in the case of indirect cooling, the last two terms in Eq. (1) (let us call them NEP_J) disappear, since there are no NIS refrigerating junctions on the thermometer. Moreover, if in three-dimensional systems we write $\dot{Q}_{ep} = \Sigma_{ep}\Omega(T_1^5 - T_{ep}^5)$ [9], $\dot{Q}_J = \Sigma_K S(T_2^4 - T_1^4)$ [8], then $\langle \delta^2 \dot{Q}_{ep,shot}(\omega) \rangle \approx 5k_B \Sigma_K \Omega (T_e^6 + T_1^6)$ [10] (the error of the approximation is within 2% for any $T_1 > T_e$) and $\langle \delta^2 \dot{Q}_{K,shot}(\omega) \rangle = 8k_B [\zeta(5)/\zeta(4)] \Sigma_K S (T_1^5 + T_2^5)$, where $\zeta(x)$ is the Riemann function, Ω is the volume of the TSE, S is the contact area between the TSE and the heat bath, while Σ_{ep} and Σ_K are coupling constants. In the case of indirect cooling, $T_e \approx T_1 \approx T_2$, while for the direct cooling $T_e < T_1 < T_2$, the exact values depending on the coupling constants and geometry. Due to the high power in the temperature dependence of the noise terms, slightly higher temperature of the lattice or of the heat bath would have a big effect on the NEP. To make this point more clear let us discuss two extreme cases. In the first case suppose that the thermal resistance between the lattice and the heat bath (Kapitza resistance) is much smaller than the one between the electrons and phonons: $|\partial \dot{Q}_K / \partial T_1| \gg |\partial \dot{Q}_K / \partial T_1|$, while in the second the inequality is reversed. We define a *critical frequency* $\omega_c \equiv |\partial \dot{Q}_K / \partial T_1| / C_{V1} = 4tv/w$, where t is the transmission coefficient for a phonon between the lattice and the heat bath [11], v is the velocity of sound in the heat bath, and w is the thickness of the TSE. For typical devices ω_c is of the order of 10^{10} s^{-1} . Therefore we can neglect in general the ω dependence of the first two terms in Eq. (1). Under such assumptions, in *case 1* the NEP reduces to

$$\begin{aligned} \text{NEP}^2 &\approx \langle \delta^2 \dot{Q}_{ep,shot}(\omega) \rangle + \langle \delta^2 \dot{Q}_{K,shot}(\omega) \rangle \\ &\quad \times \left(\frac{\partial \dot{Q}_{ep}}{\partial T_1} \right)^2 \left(\frac{\partial \dot{Q}_K}{\partial T_1} \right)^{-2} + \text{NEP}_J^2 \\ &\approx \langle \delta^2 \dot{Q}_{ep,shot}(\omega) \rangle + \text{NEP}_J^2, \end{aligned} \quad (2)$$

where the last approximation holds if $(T_2/T_1)^5$ is much smaller than the ratio between the electron-phonon and the Kapitza resistance $[(T_2/T_1)^5 (\Sigma \Omega T_1 / \Sigma_K S) \ll 1]$, which is certainly the case for indirect cooling. In the second case we have the approximation

$$\text{NEP}^2 \approx 4 \times \langle \delta^2 \dot{Q}_{ep,shot}(\omega) \rangle + \text{NEP}_J^2. \quad (3)$$

Using Eqs. (2) and (3), we can write in general the ratio between the noise equivalent power in the case of direct cooling (NEP_d) and in the case of indirect cooling (NEP_i):

$$\frac{\text{NEP}_d}{\text{NEP}_i} \approx \sqrt{\frac{T_e^6 + T_1^6}{2T_e^6} + \frac{\text{NEP}_J^2}{\text{NEP}_i^2}}. \quad (4)$$

If the working conditions require $T_e \approx 0.1 \text{ K}$ and if the lattice temperature is $T_1 \approx 0.3 \text{ K}$ [7,12,13] in the case of direct cooling, we obtain, ignoring NEP_J , a ratio $\text{NEP}_d/\text{NEP}_i \approx 19$, thus strongly favoring the indirect cooling method.

Unfortunately it is difficult to calculate the performance of NIS junctions as coolers, having the junction parameters [12,14]. This is due to the fact that the quasi-particle energy levels in the superconductor are populated during the cooling process and the superconductor has to be cooled itself using so called *normal traps for quasiparticles* [12,13]. In any case, if we suppose that the effective temperature of the superconductor is an external parameter, at low temperatures we can find analytical approximations for \dot{Q}_J . Keeping only the highest order terms in $\Delta/k_B T_e$ and $\Delta/k_B T_1$, where Δ is the energy gap in the superconductor, the optimum cooling power is $\dot{Q}_{opt,J} \approx 0.6(\Delta^2/e^2 R_T)(k_B T_e/\Delta)^{3/2} - \sqrt{2\pi k_B T_s \Delta^3} e^{-\Delta/k_B T_s}$ [7,13]. Using this equation, supposing that $T_s \approx T_1 \approx T_2 \approx 0.3 \text{ K}$ and that the superconductor is Al, with $\Delta \approx 200 \mu\text{eV}$, we can calculate the tunnel junction resistance R_T from the power balance equation. To evaluate \dot{Q}_{ep} , which also enters the power balance equation, we assume that the TSE is made of copper ($\Sigma_{ep} \approx 4 \times 10^9 \text{ WK}^{-5}\text{m}^{-3}$) and $\Omega = 1 \mu\text{m}^3$. From these we find $R_T \approx 22 \Omega$. Entering this value into the expression for NEP_J [8,15] and since $\partial \dot{Q}_J / \partial E = 0$ at the optimum bias [7], we find $\text{NEP}_J = 1.2 \times 10^{-17} \text{ W}/\sqrt{\text{Hz}}$. As a comparison, in the case of direct cooling, $\langle \delta^2 \dot{Q}_{ep,shot}(\omega) \rangle_{\text{direct}}^{1/2} \approx 1.4 \times 10^{-17} \text{ W}/\sqrt{\text{Hz}}$.

In the case of direct cooling, there is another noise contribution, say NEP'_J , due to the Johnson noise in the voltage across the NIS junctions, that should be quadratically added to NEP_J^2 . If close to the optimum bias voltage V_{opt} we write $\dot{Q}_J \approx -\gamma(V - V_{opt})^2$, then at low temperatures $\gamma \approx (0.33/R_T) \times (\pi\Delta/2k_B T_e)^{1/2}$ [8]. To evaluate the order of magnitude we write $\langle \delta^2 V(\omega) \rangle = 4k_B T_e R_T \approx 1.2 \times 10^{-23} \text{ V}^2/\text{Hz}$ and obtain $\text{NEP}'_J \approx 10^{-23} \text{ W}/\sqrt{\text{Hz}}$. Therefore NEP'_J is many orders of magnitude smaller than NEP_J so we neglect it here, but as future prospect a more rigorous investigation of the voltage fluctuations in such systems would be desirable.

In this letter we calculated the noise equivalent power (NEP) in microbolometers cooled by the direct [the refrigerator is connected to the thermal sensing element (TSE)] and the indirect [the refrigerator cools the heat bath of the TSE] method, respectively. It turned out that the NEP_J is more than an order of magnitude smaller (in our example it was 19 times smaller, in the situation in which the noise in the cooling power of the NIS junctions was not taken into account) if the TSE is cooled indirectly, the fact that would recommend this method for applications, such as the X-ray Evolving Universe Satellite (XEUS) -mission [16], currently under study by the European Space Agency. There is also the possibility of combining both methods in bolometers, which would allow significant improvement in the dynamic range of

far-infrared bolometers in terms of background saturation.

This work has been funded by the European Space Agency under contract Nos. 13006/98/NL/PA(SC) and 12835/98/NL/SB and by the Academy of Finland under the Finnish Centre of Excellence Programme 2000-2005 (Project No. 44875, Nuclear and Condensed Matter Programme at JYFL).

- [1] K. D. Irwin, G. C. Hilton, D. A. Wollman, and J. M. Martinis, *Applied Physics Letters* **69**, 1945 (1996).
- [2] A. T. Lee, P. L. Richards, S. W. Nam, B. Cabrera, and K. D. Irwin, *Appl. Phys. Lett.* **69**, 1801 (1996).
- [3] A. Luukanen, H. Sipilä, K. Kinnunen, A. Nuottajärvi, J. P. Pekola, *Physica B* **284**, 2133 (2000).
- [4] M. Nahum and J. M. Martinis, *Appl. Phys. Lett.* **63**, 3075 (1993).
- [5] M. Nahum and J. M. Martinis, *Appl. Phys. Lett.* **66**, 3203 (1995).
- [6] M. Nahum, T. M. Eiles, and J. M. Martinis. *Applied Physics Letters* **65**, 3123 (1994).
- [7] M. M. Leivo, J. P. Pekola, and D. V. Averin. *Applied Physics Letters* **68**, 1996 (1996).
- [8] D.V. Anghel and J. P. Pekola, submitted to the *Journal of Low Temperature Physics*, October 2000; cond-mat/0011111.
- [9] F. C. Wellstood, C. Urbina, and J. Clarke, *Phys. Rev. B* **49**, 5942 (1994).
- [10] S. R. Golwala, J. Jochum, B. Sadoulet, *Low Temperature Detectors* **64** (1997).
- [11] F. Pobell, *Matter and methods at low temperatures*, Springer-Verlag, Berlin and New York, 2nd edition, 1996.
- [12] J.P. Pekola, D.V. Anghel, T.I. Suppala, J.K. Suoknuuti, A.J. Manninen, and M. Manninen, *Appl. Phys. Lett.* **76**, 2782 (2000).
- [13] D. V. Anghel, *Phases and phase transitions in restricted geometries*, PhD thesis, Rap. No. 5/2000, Department of Physics, University of Jyväskylä, 2000 (unpublished).
- [14] P. A. Fisher, J. N. Ullom, and M. Nahum. *Applied Physics Letters* **74**, 2705 (1999).
- [15] D. Golubev and L. Kuzmin, Second International Workshop, “From Andreev Reflection to the International Space Station”, Gotenburg, Sweden, October 18–19, 1999 (unpublished).
- [16] M. Bavdaz, J.A. Bleeker, G. Hasinger, H. Inoue, G.G. Palumbo, A.J. Peacock, A.N. Parmar, M.J. Turner, J. Truemper, and J. Schiemann, *X-ray evolving universe spectroscopy mission (XEUS)*, in R.B. Hoover and A.B. Walker, editors, *Proc. SPIE*, volume 3766, pages 82–93, Bellingham WA, 1999. SPIE.