

Big Bang riddles and their revelations

BY JOÃO MAGUEIJO¹ AND KIM BASKERVILLE²

¹ *Theoretical Physics, The Blackett Laboratory, Imperial College, Prince Consort Road, London, SW7 2BZ, U.K.*

² *Department of Mathematical Sciences, South Road, Durham, DH1 3LE, UK.*

We describe how cosmology has converged towards a beautiful model of the Universe: the Big Bang Universe. We praise this model, but show there is a dark side to it. This dark side is usually called “the cosmological problems”: a set of coincidences and fine tuning features required for the Big Bang Universe to be possible. After reviewing these “riddles” we show how they have acted as windows into the very early Universe, revealing new physics and new cosmology just as the Universe came into being. We describe inflation, pre Big Bang, and varying speed of light theories. At the end of the millennium, these proposals are seen respectively as a paradigm, a tentative idea, and outright speculation.

Keywords: Cosmology; Inflation; String theory; Varying constants

1. The Big Bang riddles

The Big Bang Universe is a success story. It makes use of the general theory of relativity to set up the most minimalistic model for our Universe. According to this model the embryo Universe was concentrated in a single point, which exploded in a Big Bang event some 15 billion years ago. The Big Bang Universe is homogeneous in space, and expands as time progresses: a dynamical prediction of relativity. An elegant explanation for an ever growing array of observations ensues.

A closer examination of this model, however, reveals a number of unnatural features. The Big Bang Universe is fragmented into many small regions, which are so far apart light, or indeed any interaction, has not had time to travel between them. These “horizons” are therefore unaware of each other, yet mysteriously share the same properties, such as age and temperature. It almost looks as if telepathic communication has taken place between disconnected regions. Another puzzle is the observed near flatness of the Universe. Flatness is central to successful Big Bang models, but is unfortunately not stable. Big Bang models may be open (hyperbolic), flat, or closed (spherical). Closed Big Bang models expand to a maximum size, and then recollapse, dying in a Big Crunch. Open models expand too fast, leaving the Universe empty soon after the Big Bang. The problem is that even slight deviations from flatness grow very quickly, leading inevitably to either a catastrophic Big Crunch or emptiness. The fact that neither has occurred means that we are successfully walking on a tightrope. Short of invoking divine intervention how can we possibly have managed this for so long?

Thankfully a number of natural explanations have been put forward. In all of these, the riddles plaguing the Big Bang act as windows into new physics. Inflationary models of the Universe, which have become a paradigm in modern cosmology,

were undoubtedly born out of these puzzles. Inflation is perhaps the simplest addition to the Big Bang which leaves behind a Universe without mystery. Another explanation is the so-called Pre Big Bang model. This is inspired by string theory, and explores the possibility of the Universe existing before the Big Bang. In the progenitor Universe lies the secret of the riddles. The most radical explanation is a recent proposal, involving a revision of the special theory of relativity. According to this proposal light might have travelled much faster in the Early Universe. The varying speed of light cosmology explains the puzzles solved by inflation and Pre Big Bang models, and maybe some additional riddles, too.

In this paper we review the Big Bang model (Section 2), and its riddles (Section 3). We then describe solutions to these riddles: inflation (Section 4), Pre Big Bang (Section 5), and varying speed of light (Section 6). We conclude with an assessment of the state of the art.

2. The bright side of Big Bang cosmology

Cosmology, the study of the Universe, was for a long time the subject of religion. That it has become a branch of physics is a surprising achievement. Why should a system as apparently complex as the Universe ever be amenable to scientific scrutiny? At the start of this century, however, it became obvious that in a way the Universe is far simpler than say an ecosystem, or an animal. In many ways even a suspension bridge is far harder to describe than the dynamics of the Universe.

The big leap occurred as a result of the discovery of the theory of relativity, in conjunction with improvements in astronomical observations. If we look at the sky we see an overwhelming plethora of detail: planets, stars, the Milky Way, the nearby galaxies. At first the task of predicting the behaviour of the Universe as a whole looks akin to predicting the world's weather, or the currents in the oceans.

If we look harder we start to see that such structures are mere details. With better telescopes we can zoom out, to find that galaxies, clusters of galaxies, even the largest structures we can see, become “molecules” of a rather boring soup. A very homogeneous soup, called the cosmological fluid. The subject of cosmology is the dynamical behaviour of this fluid, when left to evolve according to its own gravitation. The crucial feature is the fact that this fluid appears to be expanding: its “molecules” are moving away from each other.

What set the Universe in motion? Can physics explain this phenomenon? That was one of the many historical roles played by the theory of relativity. The result is encoded in what came to be known as the Big Bang model of the Universe. Here we shall attempt to convey the essence of this model, in a Newtonian version of the theory which imports all the relevant relativistic aspects.

Let us start by assuming that the cosmological fluid is homogeneous and also that at every point all directions are equivalent, that is we have isotropy (note that homogeneity does not imply isotropy.) Isotropy requires that the only possible motion relative to any given point \mathcal{O} be radial motion. Imagine a sphere around \mathcal{O} , and consider the velocity vectors of points on this sphere. Now try to comb this sphere (that is, to add a tangential component to these velocities). There will always be a bald patch, no matter how careful one is. Such a bald patch provides a preferred direction, contradicting isotropy. Therefore isotropy is a hair raising experience, allowing only radial motion. Any observer can at most see outwards or

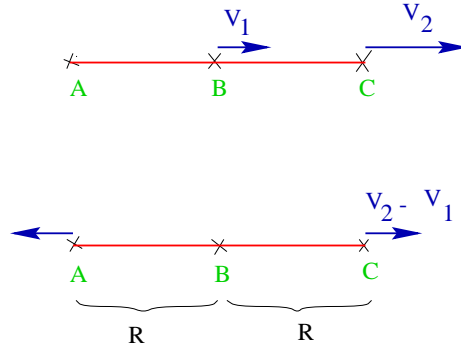

Figure 1.

inwards motion around itself. We shall assume for the rest of the argument that this motion is outwards.

The speed at which this motion takes place may depend on the distance and on time, but the function must be the same for all central points \mathcal{O} considered. This imposes constraints on the form of this function. Consider three collinear points A , B and C , with B at distance R from A and B (see Fig.1). In the rest frame of A , let the velocities of B and C be \mathbf{v}_1 and \mathbf{v}_2 (top case in Fig. 1). If we now consider the situation from the point of view of B , C is at a distance R and has velocity $\mathbf{v}_2 - \mathbf{v}_1$ (bottom case in Fig. 1). But given homogeneity, what B now sees at C should be what A sees at B . Hence $\mathbf{v}_1 = \mathbf{v}_2 - \mathbf{v}_1$, that is $\mathbf{v}_2 = 2\mathbf{v}_1$. Going back to A 's perspective, we now find that points at twice the distance move at twice the speed. More generally $\mathbf{v} = H\mathbf{d}$: the recession speed away from any point \mathcal{O} is proportional to the distance. H is called the Hubble “constant”. It is not really a constant, but may only depend on time.

This is a weird law. Any point \mathcal{O} sees the stuff of the Universe receding away from it, the faster the further away it is. Let us first simplify life, and ignore gravity, so that these speeds do not change in time. Then a cataclysm must have happened in the past. If an object at distance d is moving at speed $v = Hd$, then rewinding the film by $\delta t = d/v = 1/H$ will show that this object was ejected from \mathcal{O} . But the rewind time is the same for objects at any distance d , and is always $\delta t = 1/H$. Points further away are moving faster, and therefore crossed their greater distance from \mathcal{O} in the same time. Hence, at a time $\delta t = 1/H$ into the past, the whole observable Universe was ejected from point \mathcal{O} . But \mathcal{O} can be any point. Therefore the whole Universe started from a single point, in a big explosion: the Big Bang. Gravity complicates, but does not alter this argument.

We shall now include gravity, using O-level algebra. The lazy reader may skip this effort: the above already allows pretentious statements about creation to be made. Let us again consider the perspective of a point \mathcal{O} , and imagine a small test particle with mass m at distance \mathbf{d} . The gravitational force on the mass m is determined by the mass M inside a sphere centred at \mathcal{O} and with radius d (see Fig. 2). If ρ is the mass density of the Universe, this mass is $M = \frac{4}{3}\pi d^3 \rho$. Energy conservation requires that

$$-\frac{GMm}{d} + \frac{1}{2}mv^2 = C \quad (2.1)$$

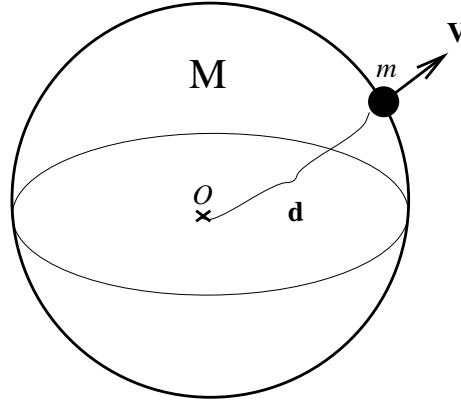

Figure 2.

(where v is m 's velocity) and Newton's law implies that

$$m\dot{v} = -\frac{GMm}{d^2} \quad (2.2)$$

where G is the gravitational constant. If we label particle m with a comoving coordinate \mathbf{l} , then we may write its position as $\mathbf{d}(t) = a(t)\mathbf{l}$. We call a the expansion factor of the Universe. The particle velocity is then $\mathbf{v} = \dot{a}\mathbf{d}$ and its acceleration is $\dot{\mathbf{v}} = \ddot{a}\mathbf{d}$. With these rearrangements we can derive the Friedmann equations:

$$\left(\frac{\dot{a}}{a}\right)^2 = \frac{8\pi G}{3}\rho - \frac{Kc^2}{a^2} \quad (2.3)$$

$$\frac{\ddot{a}}{a} = -\frac{4\pi G}{3}\left(\rho + 3\frac{p}{c^2}\right) \quad (2.4)$$

in which $K = -2C/(ml^2c^2)$. In the second equation we have included an extra term in p , the pressure in the Universe, which does not follow from the Newtonian argument. This is a correction imposed by general relativity even in the Newtonian limit. In Relativity the gravitational mass is not given by the mass density ρ alone. The pressure contributes as well. We may regard $\rho + 3p/c^2$ as the active gravitational mass density of the Universe. This subtlety will be of great importance later on.

We see that there is still a Big Bang, even when gravity is taken into account. The Friedmann equations give $a \propto t^{2/3}$ for a Universe with no pressure (dust), as $t \rightarrow 0$, regardless of the constant K . The early Universe is in fact filled with radiation, for which $p = \frac{1}{3}\rho c^2$. In this case, $a \propto t^{1/2}$ as $t \rightarrow 0$, for all K . In either case we see that $a \rightarrow 0$ as $t \rightarrow 0$, that is we have a Big Bang.

The previous argument is naturally oversimplified. As d increases the recession speed v increases until it eventually approaches the speed of light c . The Newtonian argument then breaks down, since special relativity invalidates the numerous changes of frame used. Nonetheless the Newtonian argument does give the right equations. Equations (2.3) and (2.4) are Einstein's equations for a uniform and isotropic space-time.

One significant novelty is introduced by relativity. In relativity the objects in the Universe are not moving away from each other. Rather, they are fixed in space,

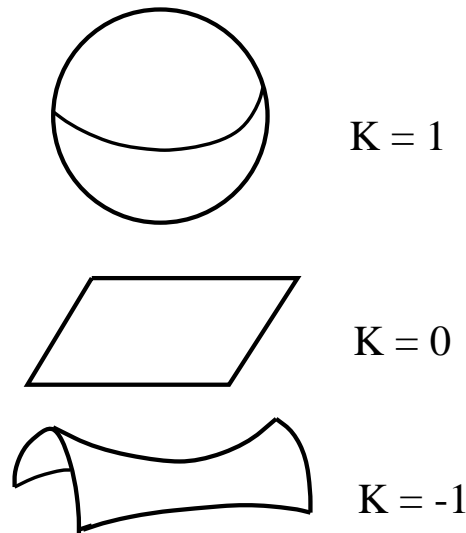

Figure 3.

and space is expanding. Another novelty is a better interpretation of the constant K which appears in the equations. This constant describes the curvature of the expanding space, and a can always be redefined so that $K = 0, \pm 1$. Given homogeneity, the expanding space can only be a 3-dimensional sphere ($K = 1$), Euclidean or flat 3-dimensional space ($K = 0$), or a 3-dimensional hyperboloid or saddle ($K = -1$). The 2-dimensional analogues are pictured in Fig. 3.

The brightest side of the Big Bang model is the prediction of Universal expansion. What set the Universe in motion? The question does not make sense. It's like asking what keeps a free particle moving, as Aristotelian physicists would do. The cosmological expansion is a generic feature of any space-time satisfying Einstein's equations, as they were written above. Only a restless Universe is consistent with relativity; and that is just what was discovered by observation.

3. The spooky side of Big Bang cosmology

The Big Bang model is a success. It offers the most minimalistic explanation for all the observations currently available. It explains the cosmic microwave background. It explains the abundances of the lighter elements, through a process called primordial nucleosynthesis. It provides an explanation for how structures, such as galaxies, form in a Universe which is very homogeneous at early times, indeed at any time at very large scales. This is only to mention a few striking successes of the Big Bang model. Competitors to the Big Bang model, such as the steady state model, lost their elegance and predictive power as more and more data accumulated.

In the late 70's, however, it became apparent that not all was a bed of roses with the Big Bang model. Even though the model proved unbeatable when confronting observation, it required a large amount of coincidence and fine tuning, which one would rather do without. These difficulties are referred to as the horizon, flatness, and Lambda problems, which we now describe (see Linde 1990 for a review).

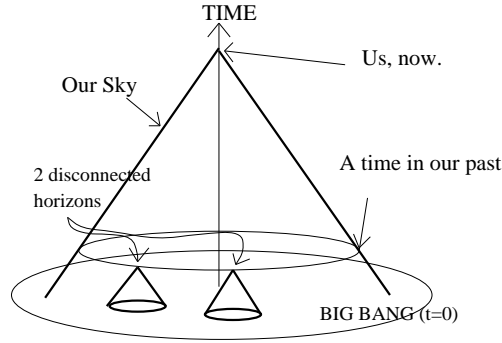

Figure 4. Conformal diagram (light at 45°) showing the horizon structure in the Big Bang model. Our past light cone contains regions outside each others' horizon.

(a) *Horizons in the Universe*

Creation entails limitation. Universes marked by a creation event, such as the Big Bang Universe, suffer from a disquieting phenomenon known as the horizon effect: observers can only see a finite portion of the Universe. The horizon effect can be qualitatively understood from the fact that, since light takes time to travel, distant objects are always seen as they were in the past. Given that creation imposes a boundary in the past, this means that for any observer there must also be a boundary in space. A distance must exist beyond which nothing can be seen, as one would be seeing objects before the creation. Such a boundary is called the horizon.

The existence of horizons is not by itself a problem. The problem is that the horizon is tiny at early times. If we ignore expansion effects, the current horizon radius is 15 billion light years, corresponding to our age of 15 billion years. When the Universe was 100,000 years old the horizon radius was only 100,000 light years. If we look far enough we can see the 100,000 year old Universe. As Fig. 4 shows, we should be able to see many regions which were outside each other's horizons at that time.

The celebrated cosmic microwave background radiation is, in fact, a glow emitted by the Universe when it was 100,000 years old. One can show that a horizon region at this time subtends in the sky an angle of about a degree, the size of the moon. We can see many of these regions, and they all agree to have the same temperature to a high degree of accuracy.

The horizon problem is our ability to see disconnected horizons in our past, and the fact that these horizons are seen to share the same properties, such as temperature or density. The horizon effect prevents any causal equilibration mechanism from explaining this remarkable coincidence. In a sense the horizon problem is really a homogeneity problem: the uncanny homogeneity of the Universe across causally disconnected regions.

Expansion complicates this reasoning a bit, but not enough to solve the problem in a Big Bang Universe. When we discuss the inflationary Universe we shall include the effects of expansion into the discussion, and show how they may be used to solve this riddle.

(b) Walking on a tightrope without falling off

The first Friedmann equation, (2.3), shows that there are two contributions to expansion. On its right hand side we see that matter and, if present, curvature contribute to expansion. How does their relative importance evolve in time?

The two Friedmann equations may be combined into a single equation

$$\dot{\rho} + 3\frac{\dot{a}}{a}\left(\rho + \frac{p}{c^2}\right) = 0 \quad (3.1)$$

which represents energy conservation. This implies that pressureless matter ($p = 0$) is diluted as $\rho \propto 1/a^3$, the dilution rate corresponding to volume expansion. Radiation ($p = \frac{1}{3}\rho c^2$) is diluted as $\rho \propto 1/a^4$, the extra factor corresponding to the fact that the radiation pressure is doing work as the Universe expands. Eqn. (2.3) then shows that the ratio between the contribution to expansion due to curvature, and that due to matter (radiation), increases with a (a^2). This means that the flat model is unstable! This conflicts with the fact that we are now close to flatness. Observations show that the contributions to expansion due to matter and curvature are at most of the same order of magnitude. How have we managed not to fall off the tightrope of flatness? This is the flatness problem.

To put numbers into the problem, we know that the Big Bang Universe has been expanding since the so-called Planck time, $t_P = 10^{-42}$ sec, when gravity became classical. We can work out that since then the expansion factor has increased by 10^{32} , or thereabouts, leading to a growth in any deviation from flatness by around 10^{64} since then. This means fine tuning the curvature contribution at Planck time by 64 orders of magnitude.

Falling off the flatness ridge is disastrous. Staring at the first Friedmann Equation (2.3) we see that closed models ($K = 1$) expand more slowly than flat models, but open models ($K = -1$) expand faster. We can follow the evolution of non-flat Universes into their curvature dominated epochs. Expansion in closed models keeps slowing down relative to flat models, until eventually expansion comes to an halt. The curvature term cannot be bigger than the matter term (since the left hand side of (2.3) must be positive). Therefore recollapse starts, retracing expansion's steps, until the Universe ends in a Big Crunch. Open models expand ever more rapidly compared to flat models. Therefore the curvature term keeps increasing until the matter is irrelevant. But this means that the Universe is destined to become totally empty. If the contribution to expansion from curvature is not negligible at Planck time, one or the other of these two tragedies would have occurred within a few Planck times.

Only flat models offer a reasonable model for the Universe as we see it. But as we saw, they are unstable, the tiniest trace of curvature sufficing to derail them.

(c) Einstein's greatest blunder

Self-flagellation has played an important role in modern science. At the start of the 20th century there was no evidence for cosmological expansion. Relativity predicts expansion, with one exception: a closed Universe dominated by a cosmological constant. The cosmological constant represents the energy of the vacuum, and it was introduced by Einstein to ward off expansion. When Hubble discovered expansion, a few years later, Einstein bitterly regretted having introduced the

cosmological constant, thus missing yet another theoretical prediction for a major experimental discovery. He called the cosmological constant “the biggest blunder of my life”.

The cosmological constant may be seen as an extra term one adds to curvature in Einstein’s equations. This term is usually represented by Λ . It may be reinterpreted as an extra fluid pervading the whole Universe, with pressure $p_\Lambda = -\rho_\Lambda c^2$, and mass density $\rho_\Lambda = \Lambda c^2/8\pi G$. The cosmological constant is the stuff the vacuum is made of.

The cosmological constant has a very negative pressure, that is, it is very tense stuff. Inserting this fact into Eqn. (3.1) leads to $\rho_\Lambda = \text{const}$. The vacuum does not get diluted by expansion! This is because expansion is doing work against the Λ tension. Therefore at the same time expansion dilutes the energy density in Λ , it transfers energy into it, via this work.

We see that any traces of the cosmological constant would immediately dominate the Universe. Defining the ratio between the energy density in normal matter and in Λ reveals that $\epsilon_\Lambda = \rho_\Lambda/\rho$ grows like a^3 for matter, and like a^4 for radiation. This means a growth by 128 orders of magnitude since Planck time, when we know the Universe expansion must have started.

We have another, even thinner, tightrope to walk on.

4. God on amphetamine

In the end, history flushed Einstein’s greatest blunder into one of the main paradigms of modern cosmology: inflation (Guth 81, Linde 82, Albrecht & Steinhardt 82, Linde 83). Inflation is a period in the early Universe during which the dominant energy contribution is the vacuum energy. Inflation is a brief affair with the cosmological constant.

Inflation is a way of switching on the cosmological constant, and then letting it decay into ordinary matter. The trick is played by a field, called the inflaton field. When the inflaton is switched on it dominates all other forms of matter, in the catastrophe described above. However this catastrophe brings luck. Integrating the Friedmann equations with $p = -\rho c^2$ leads to $a \propto e^{Ht}$, where the Hubble constant H is now indeed a constant. We have exponential expansion. The Universe therefore inflates, and this, as we shall see, is enough to solve the flatness and horizon problems.

Inflation may be achieved with stuff less extreme than a temporary cosmological constant. In fact $\rho + 3p/c^2 < 0$ is the generic condition for inflation. It means that the gravitational mass of the Universe is negative. For this reason the cosmological expansion accelerates instead of decelerating ($M < 0$ in Fig. 2). More precisely $\ddot{a} > 0$, as we can see from the second Friedmann Equation (2.4). A period of inflationary expansion is sometimes also called “superluminal expansion”.

(a) *Opening up horizons*

In our discussion of the horizon problem we neglected expansion. Let us now refine the argument. The horizon size is the distance travelled by light since the Big Bang. But is this really one light year in a one year old Universe? Travelling in an expanding Universe entails a surprise: the distance from the departure point is

larger than the distance travelled. This is because expansion keeps stretching the distance already travelled. Imagine a cosmic motorway, realized if the Earth were expanding very fast. Then a trip from London to Durham might show on the speedo that 300 miles were travelled, whereas the actual distance between the two places at the end of the trip would be 900 miles. Similarly in a 15 billion year old Universe, light would have travelled 15 billion light years since the Big Bang. However the distance to its starting point would be roughly 45 billion light years, the current size of the horizon.

This subtlety does not change the essence of the discussion of the horizon effect in Big Bang models. But inflation builds upon this subtlety. With super-luminal expansion the distance travelled by light since the start of inflation becomes essentially infinite. Under amphetaminic expansion light travels a finite distance, but expansion works “faster than light”, infinitely stretching the distance from departure.

Therefore inflation opens up the horizons. The whole observable Universe nowadays was, before inflation, a tiny bit of the Universe well in causal contact. This was then blown up by a period of inflation. We have solved the horizon problem.

(b) *The valley of flatness*

If we insert a cosmological constant into the flatness problem argument, we find a pleasant reversal of the situation. Now the contribution to expansion due to matter (which is ρ_Λ) remains constant, whereas the contribution due to curvature decays like $1/a^2$. The ratio between curvature and matter contributions now decreases like $1/a^2$ instead of increasing like a^2 . Flatness becomes a valley, rather than a ridge.

Because the expansion factor is increasing exponentially, within a very short time any deviation from flatness becomes infinitesimally small. At the end of inflation the contribution to expansion from curvature is smaller than 10^{-64} . We have achieved the fine tuning required to survive the Big Bang flatness tightrope. Inflation provides the primordial balancing pole to allow us to walk the tightrope without falling off.

(c) *The end of the nothing*

At the end of inflation the inflaton field decays into radiation, in a process known as reheating. The normal course of the Big Bang resumes. But the worst Big Bang nightmares have been staved off. It is no longer a coincidence that the Universe is homogeneous across so many disconnected horizons. All these separate horizons went to the same nursery school. The instabilities of the sensible brand of Big Bang models (the flat ones) are no longer a concern. A period of inflation finely tuned the Universe. It gave it the stability at birth required for the Universe to cope with its “instabilities” in later life.

The only problem inflation does not solve is of course the Λ problem. Inflation is built upon it. If in addition to the inflaton effective Λ , which turns on and off, there is a genuine cosmological constant, this will still be present at the end of inflation. The energy densities for the two Λ s remain constant, and therefore at fixed ratio, during inflation. Hence a genuine Λ would still threaten to dominate the Universe

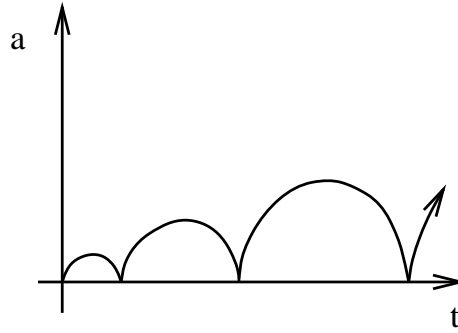

Figure 5. The scale factor evolution in the bouncing Universe.

at any time after inflation. Inflation does not provide the fine tuning required to solve the Λ instability of the Big Bang.

5. Is there life before the Big Bang?

There have been several attempts to solve the Big Bang riddles by plunging into the Planck time, $t_P = 10^{-42}$ sec, before which the temperatures in the Universe are so high that gravity, and therefore the evolution of the Universe, becomes dominated by quantum effects. Perhaps the most challenging approach is quantum cosmology, an attempt to describe the Universe with a wave function, hopefully subject to a Schroedinger-type Equation. We shall not describe this side of the story. Instead we will present a few ideas suggesting that before the Big Bang there may have been another classical period in the life of the Universe. In this previous incarnation one seeks solutions to the cosmological puzzles.

Historically the first such attempt was the Bouncing Universe (see Zeldovich and Novikov 83). Closed Universes expand to a maximum size, and then recollapse, eventually reaching a Big Crunch. What if the Crunch bounced into a Bang? This cannot be achieved classically, but may be possible due to quantum effects, although this remains a speculation. In Fig. 5 we plot the typical evolution of the scale factor a in such models. The maximum size of the Universe is related to its entropy. The second law of thermodynamics then requires that the bouncing Universe gets bigger in each cycle.

A bouncing Universe does not have an horizon. To see this let us ask the question: can a light ray in a closed Universe ever get back to its starting point? Are there Magellanic photons in a spherical Universe? The answer is yes: if a ray sets off at the Big Bang, it travels around the Universe and gets back to the departure point at the Big Crunch. Hence after the first cycle all points have been in causal contact. It is only if we are unaware of the cycles preceding our own that we may infer a horizon problem.

However it turns out that even though we have solved the horizon problem, we have not solved the homogeneity problem. Ensuring causal contact between the whole observable Universe allows for an equilibration mechanism to homogenise the whole Universe, but such a mechanism must still be proposed and be efficient enough. No such mechanism seems to be present in Bouncing Universes.

A more modern way to explore life before the Big Bang was recently inspired by

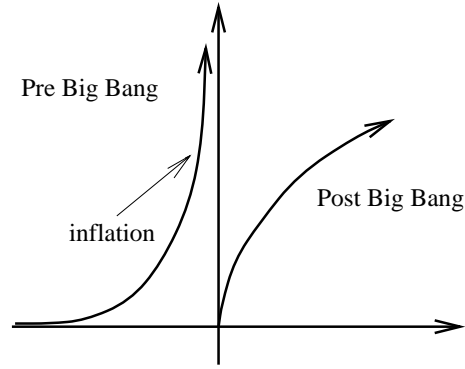

Figure 6. The scale factor evolution in Pre Big Bang cosmology

string theory (Veneziano 97, Gasperini and Veneziano 93). In string theory there are a number of duality symmetries, typically involving transforming big things into small things, and strong coupling into weak coupling. In the context of cosmology this is reflected in a scale factor transformation of the form $a(t) \rightarrow a^{-1}(-t)$. This permits the extension of the history of the Universe into times before the Big Bang, times $t < 0$. For such times the solution dual to the radiation Post Big Bang solution is $a \propto (-t)^{-1/2}$. We have accelerated expansion: $\ddot{a} > 0$, and therefore we have inflation. The typical time evolution of the scale factor is described in Fig. 6.

The PreBig Bang is really another way of getting inflation. But this time inflation occurs before the Big Bang. The Pre Big Bang scenario solves the horizon and flatness problems in the same way as inflation, but the timing is completely different.

Another aspect of the duality transformation assisting Pre Big Bang cosmology involves a field called the dilaton ϕ . The dilaton appears in all attempts to derive low energy limits to string theory. It plays the role of a coupling constant for all interactions, or rather the couplings are given by, eg, $G = e^\phi$. The duality transformation described above requires a transformation upon the dilaton of the form $\phi \rightarrow \phi + 6 \log(a)$. Hence the radiation dominated Big Bang solution, with constant dilaton $\phi = \phi_0$ (that is with stabilised constants) is mapped in the Pre Big Bang epoch into a solution of the form $\phi = \phi_0 - 3 \log(-t/t_0)$. When $t \rightarrow -\infty$ we have $\phi \rightarrow -\infty$, and so the generic coupling constant $G \rightarrow 0$. This means the Pre Big Bang Universe emerges from an epoch in which the interactions were switched off.

The overall picture is that the Universe starts from the very weak coupling regime, evolving into strong coupling. Interactions switch on. In the process inflation is also triggered, solving the riddles of the Big Bang. Deep in the strong coupling regime string theory effects become important, and lead the Universe into the Post Big Bang stage. We do not know what happens in the Bang. However we hope that the duality transformations assisting string theory will be enough to perform the mapping between these two stages in the life of the Universe.

6. Quick-light

The special theory of relativity has dominated 20th century physics. More than the general theory, the special theory has become part of the fabric of physics. Special relativity has been successfully combined with quantum mechanics, to striking effect. Quantum field theory emerged from the union, with an array of spectacular predictions leading to modern particle physics. Good examples are the discovery of new particles and antiparticles, the electroweak theory and the prospect of unification (and the crucial idea of spontaneous symmetry breaking), as well as all sorts of high precision quantitative predictions concerning interactions and their cross-sections.

Central to special relativity is the idea that the speed of light c is a constant. Regardless of the speed of the emitting or observing object, light moves at the same speed: about $300,000 \text{ Km sec}^{-1}$. Nothing can travel faster than light. The invariance of c imposes a symmetry group on physics, called Lorentz symmetry. Only if space and time transform in a specific manner between different observers can the speed of light be the same for all of them. The implications of the Lorentz transformation are immensely popular. The (Lorentz) contraction of moving bodies, time dilation and the twin “paradox” are now well known to everyone.

(a) VSL

But what if the speed of light were to change during the lifetime of the Universe? “Varying constant” theories have been proposed, starting with Dirac’s idea of varying the gravitational constant G . In attempting to explain the constants of nature one should allow them to vary, and then see if a physical mechanism can be found which crystallises their values into fixed quantities. If so we may hope that these values are the ones we observe. This project has not been terribly successful. But as a byproduct it has left us with great insights into what physics would be like if indeed the constants of nature were variables.

A good example is the Jordan-Brans-Dicke theory, in which the gravitational constant G is a variable. In this theory the gravitational constant is the result of the matter content of the Universe. As the cosmic density changes, G changes as well. Such theories have led to interesting cosmological models, and attempts to solve Big Bang riddles with them have been made, albeit unsuccessfully. Another example is the theory proposed by Bekenstein, in which the electron charge e is a field. String theories predict that all charges are in fact variable, and related to a single field, the dilaton field.

Varying speed of light (VSL) is based on a similar exercise applied to c (Moffat 93, Albrecht & Magueijo 99, Barrow 99). In the simplest implementation of VSL, c drops in a sharp phase transition in the Early Universe. Light was much faster in the Early Universe.

There is an element of criminal negligence in VSL. In VSL all observers at the same point, at the same time, but possibly moving relative to each other, see the same c . Again nothing can travel faster than light. However Lorentz symmetry is broken. And once this happens we are in the dark. Lorentz symmetry has been the guiding principle used to set up all new theories in the 20th century. If we discard it, what new guideline can we adopt?

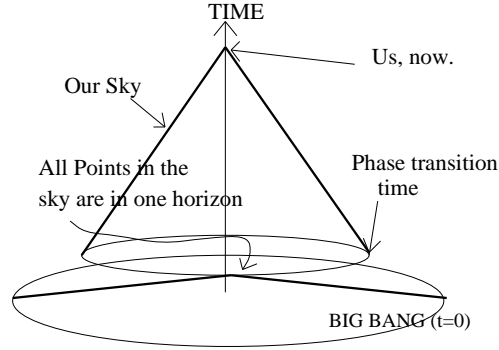

Figure 7. Diagram showing the horizon structure in a model in which at time t_c the speed of light changed from c^- to $c^+ \ll c^-$. Light travels at 45° after t_c but it travels at a much smaller angle with the space axis before t_c . Hence it is possible for the horizon at t_c to be much larger than the portion of the Universe at t_c intersecting our past light cone. All regions in our past have then always been in causal contact.

We postulate a principle of minimal coupling. This means simply to replace c by a field $c(t, \mathbf{x})$ wherever it occurs in selected laws. Such a minimal coupling principle guided the construction of other “varying constant” theories. It ensures that nothing new happens when the “varying constants” are kept fixed. It also ensures that minimal changes are introduced when “varying constants” do vary.

Minimal coupling cannot be consistently applied in all laws. We decided to apply it to the field equations: in the case of gravity, to Einstein’s equations. Curvature is not affected by VSL, and the way matter generates curvature is the same as before. In some loose sense we have General Relativity without Special Relativity.

In the context of cosmology this means simply replacing c by a variable $c(t)$ in Eqns. (2.3) and (2.4). The matter content in the Early Universe is still relativistic, so $a \propto t^{1/2}$. We don’t have superluminal expansion.

(b) Quick-light years

It is immediately obvious that quick-light in the early Universe solves the horizon problem. Look at Fig. 7, in which we redrew Fig. 4 assuming the speed of light was much larger in the Early Universe than it is nowadays, dropping to its current value in a sharp phase transition at $t = t_c$. We don’t need to play tricks with expansion in order to establish causal contact between the whole observable Universe. Even without expansion (so that $d_h = ct$ when c is constant), the quick-light pervading the Early Universe would have been enough to connect the whole observable Universe.

Suppose that the transition happened when the Universe was 1 year old. The horizon was then one quick-light year across, easily bigger than 15 billion normal-light years, if quick-light is fast enough. If such a phase transition occurred at Planck time ($t_c = t_P$), then light would need to have been 10^{32} times faster than nowadays, to solve the horizon problem.

(c) *Another valley for flatness*

Energy conservation appears in relativity as a consistency condition for Einstein's equations. For instance, before Eqns. (2.3) and (2.4) can be solved, one must satisfy conservation Eqn. 3.1, as the latter is implicit in the former two. This is only true if c is a constant. If c is allowed to vary then combining Eqns. (2.3) and (2.4) leads to

$$\dot{\rho} + 3\frac{\dot{a}}{a}\left(\rho + \frac{p}{c^2}\right) = \frac{3Kc^2}{4\pi Ga^2} \frac{\dot{c}}{c} \quad (6.1)$$

implying lack of energy conservation.

It is not surprising that energy conservation must be violated in such a theory. Conservation laws are the result of symmetries: that is the modern way to look at it. For instance conservation of angular momentum is a consequence of isotropy, the symmetry according to which the Universe looks the same in all directions. Energy conservation results from invariance under time-translations: the laws of physics are the same at all times. This is clearly not the case if the speed of light changes: the laws of physics change fundamentally as the speed of light changes. Therefore there must indeed be violations of energy conservation if $\dot{c}/c \neq 0$, as shown by Eqn. 6.1.

Lack of energy conservation pays its dividends. For a given expansion rate, \dot{a}/a , we can diagnose the geometry of the Universe by comparing its density with the density corresponding to the flat case $\rho_c = \frac{3}{8\pi} \frac{\dot{a}}{a}$ (see Eqn. 2.3). The density ρ_c is called the critical density, and if the density is supercritical, $\rho > \rho_c$, the Universe is closed; if the density is subcritical, $\rho < \rho_c$, the Universe is open. Now let us stare at Eqn. 6.1. We see that if the speed of light decreases ($\dot{c}/c < 0$), then matter is created if the Universe is open ($K = -1$ and $\rho < \rho_c$), but disappears if the Universe is closed ($K = 1$ and $\rho > \rho_c$). There is no creation or annihilation if the Universe is flat ($K = 0$ and $\rho = \rho_c$). Hence VSL creates matter if we are subcritical, subtracts it if we are supercritical. Again we have produced a valley for flatness.

It can be shown that a drop in c by 32 orders of magnitude at Planck time would provide sufficient fine tuning for a flat Universe to be seen nowadays.

(d) *Exorcising the nothing*

Finally VSL solves the cosmological constant problem. Einstein introduced Λ into his equations as an extra geometrical term. However the dynamical importance of Λ can only be inferred when we reinterpret it as a fluid, with a density which remains constant under expansion, and with $p_\Lambda = -\rho_\Lambda c^2$. The density of this fluid is $\rho_\Lambda = \Lambda c^2/(16\pi G)$, and because $\rho_\Lambda \propto c^2$, we see how a drop in c reduces the dynamical significance of Λ . If c drops by more than 64 orders of magnitude at Planck time, indeed $\rho_\Lambda \ll \rho$ nowadays. We have exorcised vacuum domination.

Celebrations of this triumph were interrupted by disturbing claims for observational evidence that the cosmic expansion is accelerating, $\ddot{a} > 0$ (Perlmutter & al 1998). This implies that Λ is still with us, and about to dominate the Universe. We are about to enter a period of inflation!

This is horrifying. All galaxies will soon recede away from us so fast that we will not be able to see them. We will soon be confined to our galaxy-island, with nothing but the Λ -vacuum to keep us company, in cosmic loneliness. We will end up in an island Universe, as Kant envisaged. Explaining why Λ is only now about to dominate

the Universe is an outstanding challenge. Why now? Why not immediately after the Planck time? Why not never?

As this review goes to press one of the authors is suffering from insomnia due to this humiliating riddle.

7. An appraisal of current cosmology

In this review we provided a rather diluted version of a very technical field. We described how the Big Bang model converted cosmology into a successful science. We showed how its riddles have provided insights into theories of the very Early Universe, when the Big Bang must be replaced by something more fundamental. We described three classes of models. Inflation is now a paradigm, Pre Big Bang models are a popular tentative idea, while VSL theories are outright speculation. In the words of a distinguished Cambridge Professor “VSL is a step back from relativity”.

In order to make this review more accessible, we highlighted the least technical aspects of the Big Bang riddles. This necessarily distorts the field. Perhaps the biggest riddle of all is the emergence of structure in a Universe known to be very homogeneous at Early times. All the above theories can answer this riddle, but in ways too technical for a light hearted review like this one.

Nonetheless structure formation is really the testing ground where experiment may one day decide between all these ideas. We can measure the properties of galaxy clustering, and also the power spectrum in the cosmic microwave background (CMB) anisotropies. Theories of the Early Universe make very different predictions for these observations. A new generation of satellite CMB experiments, plus new galaxy surveys, leave us at a threshold. In the 21st century it could well be decided which if any of the above ideas is correct.

The most exciting possibility is of course that all the current ideas are proved wrong. For that reason we believe that this is a bad time to adopt a dogmatic view in cosmology. Instead, we should try out as many new ideas as possible. Who knows, even so they may still all be wrong. We advocate promiscuity in science.

Acknowledgements JM is indebted to Andy Albrecht, John Barrow, and John Moffat, for shaping his views on the cosmological problems. We thank the referee and David Singleton for forcing us to clarify the more obscure parts of the text. We finally acknowledge financial support from the Royal Society (JM) and PPARC (KB).

References

- A. Albrecht and J. Magueijo, *Phys.Rev.* **D 59** 043516 (1999).
- A. Albrecht and P. Steinhardt, *Phys.Rev.Lett.* **48** 1220 (1982).
- J. Barrow, *Phys.Rev.D*59 043515 (1999).
- A. Guth, *Phys.Rev.* **D23** 347 (1981).
- A. Linde, *Phys. Lett* **B 108**, 1220 (1982).
- A. Linde *Phys. Lett* **B 129**, 177 (1983).
- A. Linde, *Inflation and quantum cosmology*, Academic Press, 1990.
- J. Moffat, *International Journal of Physics D*, Vol. 2, No. 3 (1993) 351-365.

- S. Perlmutter et al (The Supernova Cosmology project), *Nature* **391** 51 (1998).
M. Gasperini and G. Veneziano, *Astropart. Phys.* **1**, 317 (1993).
Ya. Zeldovich and I. Novikov, *Relativistic Astrophysics II*, University of Chicago Press, 1983.