

Coupling Impedances of Azimuthally Symmetric Obstacles of Semi-Elliptical Shape in a Beam Pipe*

Robert L. Gluckstern and Sergey S. Kurennoy[†]
Physics Department, University of Maryland, College Park, MD 20742

The beam coupling impedances of small axisymmetric obstacles having a semi-elliptical cross section along the beam in the vacuum chamber of an accelerator are calculated at frequencies for which the wavelength is large compared to a typical size of the obstacle. Analytical results are obtained for both the irises and the cavities with such a shape which allow simple estimates of their broad-band impedances.

I. INTRODUCTION

High currents in modern accelerators and colliders severely restrict the allowed coupling impedance of the machine. For this reason, it is important to know the impedance contributions even from small discontinuities of the vacuum chamber.

In a recent paper [1], Kurennoy has analytically calculated the low-frequency coupling impedance of small obstacles protruding into a beam pipe. In this paper we present an alternative derivation for an azimuthally symmetric semi-elliptical object protruding into a beam pipe, which confirms the dependence on the depth, but not on the width, of the protrusion. We also study the more difficult — from the analytical point of view — case of an axisymmetric semi-elliptical protrusion *outside* the beam pipe (cavity), and present variational results for different elliptical eccentricities.

II. GENERAL ANALYSIS

Consider a beam pipe of radius R_{pipe} and an azimuthally symmetric obstacle whose dimensions are small compared with both R_{pipe} and λ , the rf wavelength. We start with the definition of the longitudinal impedance as [2]

$$Z_{\parallel}(k) = \frac{1}{|I_0|^2} \int dv \vec{E} \cdot \mathbf{J}^*, \quad (2.1)$$

where the current in the frequency domain for an ultra-relativistic point charge is

$$\mathbf{J}_z(x, y, z; k) = I_0 \delta(x) \delta(y) \exp(-jkz), \quad (2.2)$$

with $k = w/c = 2\pi/\delta$, and with the implied time dependence of all quantities being $\exp(jwt)$. We then identify two configurations: the subscript 1 denotes the pipe without the obstacle and the subscript 2 denotes the pipe with the obstacle. By forming the combination

$$- \int dv (\mathbf{E}_2 \cdot \mathbf{J}^* + \mathbf{E}_1^* \times \mathbf{J})$$

and using Maxwell's equations to write \mathbf{J} in terms of the fields \mathbf{E} and \mathbf{H} , we write the contribution of the obstacle to the impedance as

$$|I_0|^2 Z_u(k) = \int_{S_2 \neq S_1} dS_2 \mathbf{n}_2 \cdot \mathbf{E}_1^* \times \mathbf{H}_2, \quad (2.3)$$

where the surface integral is only over the surface of the obstacle. Using

$$\mathbf{E}_{1r}^* = \frac{Z_0 I_0^*}{2\pi r} \exp(jkz) \quad (2.4)$$

and

$$\mathbf{n}_2 dS_2 = 2\pi r [\hat{\mathbf{n}} dz - \hat{\mathbf{z}} dr], \quad (2.5)$$

with $\hat{\mathbf{r}}$ and $\hat{\mathbf{z}}$ being unit vectors, we have

$$\frac{Z_{\parallel}(k)}{Z_0} = -\frac{1}{I_0} \int dr H_{2\phi} e^{jkz}. \quad (2.6)$$

Figure 1 show the geometry for an obstacle protruding into and outside of the beam pipe.

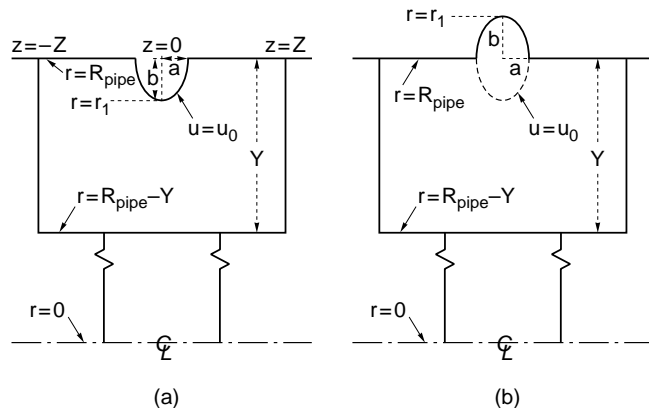

FIG. 1. The beam pipe with an interior (a) and exterior (b) obstacle. One assumes $a, b \ll Y, Z \ll \lambda, R_{\text{pipe}}$.

*Work supported by the U.S. Department of Energy

[†]Present address: AOT-1, LANL, Los Alamos, NM 87545

A more explicit form for Eq. (2.6) is

$$\frac{Z_{\parallel}(k)}{Z_0} = -\frac{1}{I_0} \left[\int_{R_{\text{pipe}}}^{r_1} dr H_{2\phi}(r, z_a(r)) e^{jkz(r)} + \int_{r_1}^{R_{\text{pipe}}} dr H_{2\phi}(r, z_b(r)) e^{jkz(r)} \right] \quad (2.7)$$

We now convert the bracket in Eq. (2.7) to a double integral for the obstacle in Fig. 1a:

$$\begin{aligned} [] &= \int_{r_1}^{R_{\text{pipe}}} \int_{-Z}^{z_a(r)} dz \frac{\partial}{\partial z} (H_{2\phi} e^{jkz}) \\ &+ \int_{r_1}^{R_{\text{pipe}}} dr (H_{2\phi} e^{jkz}) \Big|_{z=-Z} \\ &+ \int_{r_1}^{R_{\text{pipe}}} dr \int_{z_b(r)}^Z dz \frac{\partial}{\partial z} (H_{2\phi} e^{jkz}) \\ &- \int_{r_1}^{R_{\text{pipe}}} dr (H_{2\phi} e^{jkz}) \Big|_{z=Z}. \end{aligned} \quad (2.8)$$

Here Z is a distance large compared with the dimensions of the obstacle, but small compared with λ and R_{pipe} , so that $H_{2\phi} \exp(jkz)$ takes on its value in a pipe without an obstacle at $z = \pm Z$, namely

$$H_{2\phi}(\pm Z) = I_0 \exp(\mp jkZ). \quad (2.9)$$

This causes the 2nd and 4th terms on the right side of Eq. (2.8) to cancel. We also add the vanishing term

$$\int_{R_{\text{pipe}}-Y}^{r_1} dr \int_{-Z}^Z dz \frac{\partial}{\partial z} (H_{2\phi} e^{jkz}), \quad (2.10)$$

and finally obtain

$$\frac{Z_{\parallel}(k)}{Z_0} = \frac{1}{I_0} \iint_{\text{border}}^{\text{solid}} dr dz \frac{\partial}{\partial z} (H_{2\phi} e^{jkz}), \quad (2.11)$$

where the area of integration is within the solid border in Fig. 1a. Parallel arguments lead to the same result for the obstacle in Fig. 1b.

We now use Maxwell's equations to rewrite Eq. (2.11) as

$$\frac{Z_{\parallel}(k)}{Z_0} = -\frac{jk}{Z_0 I_0} \iint_{\text{border}}^{\text{solid}} dr dz (E_r - Z_0 H_{\phi}) e^{jkz} \quad (2.12)$$

where we have dropped the subscript 2. For low frequency we set $\exp(jkz) = 1$ and obtain

$$\frac{Z_{\parallel}(k)}{Z_0} \cong -\frac{jk}{Z_0 I_0} \iint_{\text{border}}^{\text{solid}} dr dz (E_r - Z_0 H_{\phi}). \quad (2.13)$$

Clearly our derivation has resulted in a separation into a term involving the electric polarizability and a term involving the magnetic susceptibility (in the azimuthal

direction) as in previous work [3–6]. Since the obstacles are azimuthally symmetric, we can replace $Z_0 H_{\phi}$ in the vicinity of the obstacle by

$$Z_0 H_{\phi} = E_0 = Z_0 I_0 / (2\pi R_{\text{pipe}}) \quad (2.14)$$

and find

$$\frac{Z_{\parallel}(k)}{Z_0} = \frac{jk}{2\pi R_{\text{pipe}}} \iint_{\text{border}}^{\text{solid}} dr dz \left(\frac{E_r - E_0}{E_0} \right). \quad (2.15)$$

III. SEMI-ELLIPTICAL INTERIOR OBSTACLE — IRIS

We now proceed to calculate Eq. (2.15) explicitly for the geometry of Fig. 1a. We change from the variable r to the variable

$$y = R_{\text{pipe}} - r, \quad (3.1)$$

with $|y| \ll \lambda$, $|y| \ll R_{\text{pipe}}$, and we use elliptical coordinates [7] defined by

$$\left. \begin{aligned} y &= c \cosh u \cos v, & z &= c \sinh u \sin v \\ a &= c \sinh u_0, & b &= c \cosh u_0, & c^2 &= b^2 - a^2 \end{aligned} \right\}. \quad (3.2)$$

The metric (Jacobian) is defined by

$$dz dy = c^2 D(u, v) du dv, \quad (3.3)$$

where

$$D(u, v) = \cosh^2 u \sin^2 v + \sinh^2 u \cos^2 v, \quad (3.4)$$

and the Laplacian operator can be written as

$$\frac{\partial^2}{\partial x^2} + \frac{\partial^2}{\partial y^2} = \frac{1}{c^2 D(u, v)} \left(\frac{\partial^2}{\partial u^2} + \frac{\partial^2}{\partial v^2} \right). \quad (3.5)$$

The solution to Laplace's equation for the electrostatic potential in the region $u \geq u_0$, with $\Psi(u_0, v) = 0$, and with the asymptotic field E_0 , is

$$\Psi(u, v) = c E_0 \cos v [\cosh u - e^{u_0 - u} \cosh u_0] \quad (3.6)$$

where

$$\begin{aligned} E_r &= -\frac{\partial \Psi}{\partial r} = \frac{\partial \Psi}{\partial y} \\ &= E_0 - c E_0 e^{u_0} \cosh u_0 \frac{\partial}{\partial y} (\cos v e^{-u}). \end{aligned} \quad (3.7)$$

Here we choose $\cos v$ in the second term to preserve the symmetry around $v = 0$ ($z = 0$), and to satisfy the boundary condition for all v at $u = u_0$ and for $v = \pm\pi/2$ with $u \geq u_0$. Also we have

$$\begin{aligned} \frac{\partial}{\partial y} &= \frac{\partial u}{\partial y} \frac{\partial}{\partial u} + \frac{\partial v}{\partial y} \frac{\partial}{\partial v} \\ &= \frac{1}{c D(u, v)} \left[\sinh u \cos v \frac{\partial}{\partial u} - \cosh u \sin v \frac{\partial}{\partial v} \right]. \end{aligned} \quad (3.8)$$

Applying this to Eq. (3.7) for $E_r - E_0$, we find from Eq. (3.6) that

$$\begin{aligned} \frac{Z_{\parallel}(k)}{Z_0} &= \frac{-jkc^2}{2\pi R_{\text{pipe}}} e^{u_0} \cosh u_0 \times \\ &\int \int dudv [\cos^2 v e^{-u} \sinh u - \sin^2 v e^{-u} \cosh u] \\ &= \frac{jkc^2 e^{u_0} \cosh u_0}{2R_{\text{pipe}}} \int \int_{\text{border}}^{\text{solid}} dudv [e^{-2u} - \cos 2v], \end{aligned} \quad (3.9)$$

where we have used Eq. (2.14).

We now let $Z \rightarrow \infty$ and cut off the integration over v where

$$\begin{aligned} y &= c \cosh u_{\text{max}} \cos v = Y, \quad \text{or} \\ u_{\text{max}} &= \cosh^{-1} \frac{Y}{c \cos v} \gg 1. \end{aligned} \quad (3.10)$$

This leads to

$$\begin{aligned} \frac{Z_{\parallel}(k)}{Z_0} &= \frac{jkc^2 e^{u_0} \cosh u_0}{4\pi R_{\text{pipe}}} \int_{-\frac{\pi}{2}}^{\frac{\pi}{2}} dv \int_{u_0}^{u_{\text{max}}} du [e^{-2u} - \cos v] \\ &\cong \frac{jkc^2 e^{u_0} \cosh u_0}{4\pi R_{\text{pipe}}} \left[\frac{\pi}{2} e^{-2u_0} \right. \\ &\quad \left. - \int_{-\frac{\pi}{2}}^{\frac{\pi}{2}} dv \cos 2v \left(\ln \frac{2Y}{c \cos v} - u_0 \right) \right], \end{aligned} \quad (3.11)$$

or

$$\frac{Z_{\parallel}(k)}{Z_0} = \frac{jkc^2 \cosh^2 u_0}{4R_{\text{pipe}}} = \frac{jkb^2}{4R_{\text{pipe}}} \quad (3.12)$$

where the last integral in (3.11) was done by parts for $Y \gg c$.

For $a > b$ we need to modify our elliptical coordinates so that

$$\left. \begin{aligned} y &= c \sinh u \sin v, \quad z = c \cosh u \cos v \\ a &= c \cosh u_0, \quad b = c \sinh u_0, \quad c^2 = a^2 - b^2 \end{aligned} \right\}. \quad (3.13)$$

The matrix is unchanged, but now

$$\frac{\partial}{\partial y} = \frac{1}{D(u, v)} \left[\frac{\cosh u \sin v}{c} \frac{\partial}{\partial u} + \frac{\sinh u \cos v}{c} \frac{\partial}{\partial v} \right]. \quad (3.14)$$

This time one finds

$$\frac{Z_{\parallel}(k)}{Z_0} = \frac{jkc^2 \sinh^2 u_0}{4R_{\text{pipe}}} = \frac{jkb^2}{4R_{\text{pipe}}}, \quad (3.15)$$

that is the result is unchanged from Eq. (3.12), again depending only on the depth of the elliptical protrusion into the pipe and not on its width, as also found by Kurennoy [1].

IV. SEMI-ELLIPTICAL EXTERIOR OBSTACLE — CAVITY

A. Analytical Approach

We now turn to the exterior semi-elliptical obstacle in Fig. 1b. Here we need to choose appropriate potential forms for $u \leq u_0$, and for $u \geq u_0$, and match them at $u = u_0$.

We again start with Eq. (2.15) and work with the complete set of solutions of the Laplace equation, namely $\cos nv \exp(\pm nu)$ and $\sin nv \exp(\pm nu)$. For $u \geq u_0$, (and $b > a$) with the asymptotic field E_0 , we choose

$$\Psi(u, v) = E_0 y - cE_0 \sum_{n=1}^{\infty} \alpha_n \cos nve^{-nu} \quad (4.1)$$

in order to satisfy the even symmetry about $v = 0$ ($z = 0$) and $\Psi(u, \pm\pi/2) = 0$ for $u \geq u_0$. If we write

$$\Psi(u_0, v) = cE_0 f(v), \quad (4.2)$$

where $f(v)$ is, as yet, an unknown function, we can solve for α_n in terms of $f(v)$ to obtain

$$\alpha_n = -\frac{2}{\pi} e^{nu_0} f_n + e^{u_0} \cosh u_0 \delta_{n1}, \quad (4.3)$$

where

$$f_n \equiv \int_{-\frac{\pi}{2}}^{\frac{\pi}{2}} dv \cos nv f(v). \quad (4.4)$$

For $u \leq u_0$, we write

$$\Psi(u, v) = \sum_{m=1}^{\infty} \beta_m \cos nv \cosh mu \quad (4.5)$$

for a potential which is well behaved within the ellipse. Recognizing in this case that $f(v) = 0$ for $\pi/2 < |v| < \pi$, we solve for β_m in terms of $f(v)$ to obtain

$$\beta_m = \frac{f_m}{\pi \cosh mu_0}, \quad (4.6)$$

where f_m is consistent with the definition in Eq. (4.4). Both odd and even values of m must be included.

We now calculate the impedance as we did in the previous section, this time including the regions $u \geq u_0$, $|v| \leq \pi/2$ and $u \leq u_0$, $|v| \leq \pi$. For $u \geq u_0$ we find

$$\begin{aligned} \frac{Z_{\parallel}^{(>)}(k)}{Z_0} &= -\frac{jkc^2}{4\pi R_{\text{pipe}}} \int \int_{y < Y}^{u \geq u_0} dudv \sum_{\substack{n=1 \\ \text{odd}}}^{\infty} n \alpha_n \times \\ &\left[e^{-(n-1)u} \cos(n+1)v - e^{-(n+1)u} \cos(n-1)v \right]. \end{aligned} \quad (4.7)$$

Clearly, only the terms with $n = 1$ survive, leading ultimately to

$$\frac{Z_{\parallel}^{(>)}(k)}{Z_0} = \frac{jk c^2}{4R_{\text{pipe}}} \alpha_1 e^{-u_0} \cosh u. \quad (4.8)$$

For $u \leq u_0$ we separate the two terms in Eq. (2.15). The second is simply

$$\frac{Z_{\parallel,2}^{(<)}(k)}{Z_0} = \frac{jkab}{\pi 4R_{\text{pipe}}} = \frac{jk c^2 \cosh u_0 \sinh u_0}{4R_{\text{pipe}}} \quad (4.9)$$

The first is

$$\begin{aligned} \frac{Z_{\parallel,1}^{(<)}(k)}{Z_0} &= -\frac{jk c^2}{4\pi R_{\text{pipe}}} \iint_{u \leq u_0} dudv \\ &\times \sum_{m=1}^{\infty} m \beta_m [\cosh(m+1)u \cos(m-1)v \\ &\quad + \cosh(m-1)u \cos(m+1)v]. \end{aligned} \quad (4.10)$$

Again, only the term $m = 1$ survives, and is

$$\frac{Z_{\parallel,1}^{(<)}(k)}{Z_0} = -\frac{jk c^2}{4R_{\text{pipe}}} \beta_1 \cosh u_0 \sinh u_0. \quad (4.11)$$

Using Eqs. (4.3) and (4.6) we have for the impedance

$$\frac{Z_{\parallel}(k)}{Z_0} = \frac{jk}{2R_{\text{pipe}}} \left[\frac{b^2}{2} + ab - (a+b)^2 \frac{f_1}{\pi} e^{-u_0} \right]. \quad (4.12)$$

In order to find f_1 , we must obtain and solve the integral equation which represents the match of $\partial\Psi/\partial u$ at $u = u_0$, $|v| \leq \pi/2$. Here

$$\begin{aligned} \frac{\partial\Psi}{\partial u} \Big|_{u=u_{o+}} &= cE_0 \left[\sinh u_0 \cos v \right. \\ &\quad \left. + \sum_{\substack{n=1 \\ \text{odd}}}^{\infty} n \alpha_n e^{-nu_0} \cosh v \right] \end{aligned} \quad (4.13)$$

and

$$\frac{\partial\Psi}{\partial u} \Big|_{u=u_{o-}} = cE_0 \sum_{m=1}^{\infty} m \beta_m \sinh mu_0 \cos mv. \quad (4.14)$$

Equating Eqs. (4.13) and (4.14), and using Eqs. (4.3) and (4.6), we find

$$\int_{-\pi/2}^{\pi/2} dv' f(v') K(v, v') = \pi \cos v e^{u_0} \quad (4.15)$$

where

$$\begin{aligned} K(v, v') &= \sum_{\substack{n=1 \\ \text{odd}}}^{\infty} (2 + \tanh nu_0) n \cos nv \cos v' \\ &\quad + \sum_{\substack{m=2 \\ \text{even}}}^{\infty} m \tanh mu_0 \cos mv \cos mv'. \end{aligned} \quad (4.16)$$

We now multiply Eq. (4.15) by $\int_{-\pi/2}^{\pi/2} dv f(v)$ to obtain

$$\begin{aligned} \frac{\left[\int_{-\pi/2}^{\pi/2} dv f(v) \cos v \right]^2}{\int_{-\pi/2}^{\pi/2} dv f(v) \int_{-\pi/2}^{\pi/2} dv' f(v') K(v, v')} &= \frac{\int_{-\pi/2}^{\pi/2} dv f(v) \cos v}{\pi e^{u_0}} \\ &= \frac{f_1 e^{-u_0}}{\pi}. \end{aligned} \quad (4.17)$$

This is a variational form for f_1 , the only unknown parameter in Eq. (4.12) for the impedance. An accurate numerical value for $Z_{\parallel}(k)/Z_0$ can be found by expanding $f(v)$ into a complete set in the interval $|v| \leq \pi/2$, then truncating and solving the resulting matrix equations obtained by maximizing Eq. (4.17). We write

$$f(v) = \sum_{\substack{p=1 \\ \text{odd}}}^P c_p \sin\left(p \frac{\pi}{2}\right) \frac{\cos pv}{p}, \quad (4.18)$$

truncated at $p = P$ and normalize $f(v)$ so that $c_1 = 1$. This leads to

$$\begin{aligned} \frac{f_1 e^{-u_0}}{\pi} &= \left[H_{11} + 2 \sum_{\substack{p=3 \\ \text{odd}}}^P c_p H_{p1} \right. \\ &\quad \left. + \sum_{\substack{p=3 \\ \text{odd}}}^P \sum_{\substack{q=3 \\ \text{odd}}}^P c_p c_q H_{pq} \right]^{-1}, \end{aligned} \quad (4.19)$$

where the symmetric matrix H_{pq} is

$$\begin{aligned} H_{pq} = H_{qp} &= \frac{2 + \tanh pu_0}{P} \delta_{pq} \\ &\quad + \frac{16}{\pi^2} \sum_{\substack{m=2 \\ \text{even}}}^{\infty} \frac{m \tanh mu_0}{(m^2 - p^2)(m^2 - q^2)}. \end{aligned} \quad (4.20)$$

Maximizing Eq. (4.19) with respect to the coefficients c_p , $p = 3, 5, \dots, P$, leads to

$$\frac{f_1 e^{-u_0}}{\pi} = \left[H_{11} - \sum_{\substack{p=3 \\ \text{odd}}}^P \sum_{\substack{q=3 \\ \text{odd}}}^P H_{1p} (H^{-1})_{pq} H_{q1} \right]^{-1}. \quad (4.21)$$

Here $(H^{-1})_{pq}$ is the inverse of the matrix H_{pq} with p and $q = 3, 5, 7 \dots P$. This square matrix has the dimension

$$(P-1)/2 \text{ by } (P-1)/2. \quad (4.22)$$

Note that

$$\tanh pu_0 = (1 - w^p) / (1 + w^p) \quad (4.23)$$

and

$$\tanh mu_0 = (1 - w^m) / (1 + w^m) \quad (4.24)$$

with

$$w = (b - a)/(b + a). \quad (4.25)$$

The final result for the impedance is given in Eq. (4.12), using Eqs. (4.20) and (4.21).

The analysis for an obstacle with $a > b$ proceeds in a similar, but not identical pattern. The result is once again Eq. (4.12), using Eqs. (4.20) and (4.21), with only one change in Eq. (4.20):

$$\tanh pu_0 \rightarrow \coth pu_0,$$

with $\tanh u_0$ now being a/b instead of b/a . Thus w in Eq. (4.25) is replaced by $-w$ in Eq. (4.23), but the use of $\coth pu_0$ instead of $\tanh pu_0$ for odd p leaves the expression for H_{pq} in terms of a and b unchanged. The same is true for the term $\tanh mu_0$ in Eq. (4.24) since m is even. So the final expression in Eq. (4.12) is unchanged provided H_{pq} in Eqs. (4.20) and (4.21) is expressed in terms of a and b .

B. Variational Approach - Numerical Results

We proceed with a numerical investigation of the variational scheme described by Eqs. (4.12)-(4.21). Truncating the sum in the denominator of Eq. (4.21) at different $N = (P - 1)/2 = 1, 2, 3, \dots$, we explore the scheme convergence, and compare the results for the impedance (4.12) with those obtained by other methods. In doing so, it is convenient to rewrite Eq. (4.12) in the following form

$$\frac{Z_{\parallel}(k)}{Z_0} = \frac{jk}{2\pi R_{\text{pipe}}} \frac{\pi ab}{2} F\left(\frac{a}{b}\right), \quad (4.26)$$

where

$$F(x) = \frac{1}{x} + 2 - \frac{2(1/x + 2 + x)}{2 + x + 16s(x)/\pi^2 - \Sigma(x)}, \quad (4.27)$$

and

$$s(x) = \frac{1}{8} \sum_{n=1}^{\infty} \frac{n}{(n^2 - 1/4)^2} \frac{(1+x)^{2n} - (1-x)^{2n}}{(1+x)^{2n} + (1-x)^{2n}}. \quad (4.28)$$

Here $\Sigma(x)$ denotes the sum in the denominator of Eq. (4.21) which is to be truncated.

The advantage of the representation (4.26) is that we know the asymptotic behavior of $F(x)$ for two limiting cases. For $x \ll 1$, i.e., when $a \ll b$, but still $b \ll R_{\text{pipe}}$ — a short and deep enlargement — it has been demonstrated in [8] that

$$F(x) \rightarrow 1 - \frac{4}{\pi^2} x. \quad (4.29)$$

In this limit, the inductive impedance in Eq. (4.26) is mostly of magnetic origin: the beam magnetic field fills

the cavity volume without being substantially perturbed, and therefore the inductance is simply proportional to the area of the obstacle cross section. A correction of the order of $x = a/b$ to this term comes from the electric contribution. For a deep pillbox of depth h which is much larger than width g , the electric contribution was calculated in [8] by means of conformal mapping. It results in the electric term $-g^2/(2\pi)$, which is small compared to the magnetic one, equal to hg for such a pillbox. Obviously, the shape of a short and deep enlargement — rectangular or semi-elliptical — does not affect the electric term as long as $g \ll h$, since the beam electric field does not penetrate deeply into such a cavity, unlike the magnetic one. Substituting $g = 2a$ into the electric term, and replacing the pillbox area hg by the semi-ellipse area $\pi ab/2$ leads to the asymptotic form in Eq. (4.29).

The opposite limit, $x \gg 1$, corresponds to a very shallow cavity, $a \ll b$. It has been shown for many particular shapes of such cavities (see [8] and references therein) that the low-frequency impedance of a small shallow cavity of the depth h and of an iris with the same cross section and having the same depth, are both inductive, equal to each other, and in the leading order are proportional to h^2 . Since we already know the answer for a semi-elliptical iris (see Section III) we expect that for $x \gg 1$

$$F(x) \rightarrow \frac{1}{x}, \quad (4.30)$$

to match the low-frequency impedance of the shallow iris, given in Eq. (3.15).

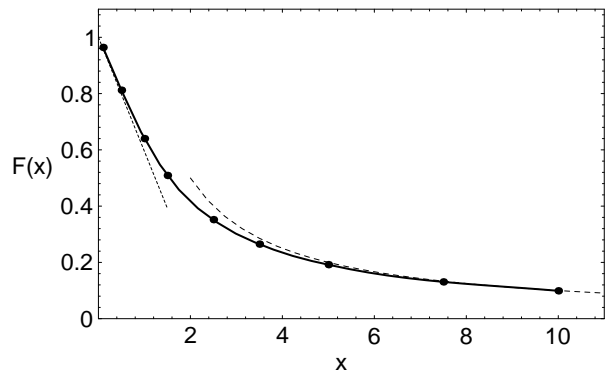

FIG. 2. Function $F(x)$ versus ellipse aspect ratio $x = a/b$. The solid curve is an interpolation of numerical results (thick points). The dashed lines show the asymptotic behavior Eqs. (4.29) and (4.30).

The results of our numerical study are shown in Fig. 2, where the function $F(x)$ is plotted against the ellipse aspect ratio $x = a/b$. The convergence of the variational scheme is rather fast for all values of x ; in fact, results obtained with $N = 1$ (i.e., when the matrix in the sum $\Sigma(x)$ is truncated to merely a single number) and those for $N = 8$, when the matrix has size 8×8 , differ by less than 0.5%. And, of course, we can obtain the asymptotic

value of $F(x)$ for large N with much better accuracy, well below 10^{-3} , simply by extrapolating the results for different matrix sizes at fixed x . Figure 2 also shows very good agreement with the expected asymptotic behavior Eq. (4.29) for small x and Eq. (4.30) for large x .

V. TRANSVERSE COUPLING IMPEDANCE

We start with a dipole drive current for the transverse impedance in the form [9]

$$J_z(x, y, z; k) = I_0 \delta(y) \exp(-jkz) \times [\delta(x - x_1) - \delta(x + x_1)], \quad (5.1)$$

where we eventually proceed to the limit $x_1 \rightarrow 0$. It is straightforward to show [9] that the transverse impedance in the x direction can be written as

$$Z_x(k) = -\frac{1}{4kx_1^2 |I_0|^2} \int dv \mathbf{E} \cdot \mathbf{J}^*, \quad (5.2)$$

analogous to Eq. (2.1) for the longitudinal impedance. Use of Maxwell's equations as we did in Section II, leads to

$$Z_x(k) = -\frac{1}{4kx_1^2 |I_0|^2} \int_{S_2 \neq S_1} dS_z \mathbf{n}_2 \cdot \mathbf{E}_1^* \times \mathbf{H}_2, \quad (5.3)$$

but we must now use the form of \mathbf{E}_1 (and \mathbf{H}_2) appropriate to the source current in Eq. (4.26). In fact, we now have for \mathbf{E}_1 and $Z_0 \mathbf{H}_1$ at the beam pipe wall

$$E_{1r} = Z_0 H_{1\phi} = \frac{2Z_0 I_0}{\pi R_{\text{pipe}}^2} x_1 \cos \phi \exp(-jkz) \quad (5.4)$$

$$E_{1\phi} = Z_0 H_{1r} = 0.$$

As a result, we can write

$$\frac{Z_x(k)}{Z_0} \cong -\frac{1}{2kx_1 I_0 Z_0 \pi R_{\text{pipe}}} \times \int d\phi \cos \phi \int dr (Z_0 H_{2\phi} e^{jkz}). \quad (5.5)$$

Once again we have written the impedance as an integral along the surface of the obstacle, where $H_{2\phi}$ arises from the driving field components E_{1r} and $H_{1\phi}$ at the wall. Dropping the subscript 2, extracting the factor $\cos \phi$ from H_ϕ and integrating over ϕ leads to

$$\frac{Z_x(k)}{Z_0} \cong -\frac{1}{2kx_1 I_0 Z_0 R_{\text{pipe}}} \int dr (Z_0 H_\phi e^{jkz}). \quad (5.6)$$

We now write Eq. (5.6) as a double integral over $drdz$ as we did in Section II, obtaining

$$\frac{Z_x(k)}{Z_0} = \frac{-j}{R_{\text{pipe}}^3} \int_{\text{border}}^{\text{solid}} dr \int dz \left(\frac{E_r - E_0}{E_0} \right) \quad (5.7)$$

where E_0 , the maximum asymptotic field at the wall, is

$$E_0 = \frac{2Z_0 I_0}{\pi R_{\text{pipe}}^2} x_1. \quad (5.8)$$

Comparison of Eq. (5.8) with Eq. (2.15) shows that the calculations for an exterior and an interior obstacle are exactly the same as they were for the longitudinal impedance. In fact, the results for the transverse impedance can be obtained simply by multiplying the results for the longitudinal impedance in Eqs. (3.12), (3.15), (4.12) and (4.21) by $2/kR_{\text{pipe}}^2$.

-
- [1] S.S. Kurennoy, "Beam Coupling Impedances of Obstacles Protruding into Beam Pipe", submitted to Phys. Rev. E.
 - [2] R.L. Gluckstern and F. Neri, IEEE Trans. Nucl. Sci., NS-**32**, 2403 (1983).
 - [3] H.A. Bethe, Phys. Rev. **66**, 163 (1944).
 - [4] R.E. Collins, *Field Theory of Guided Waves* (IEEE Press, NY, 1991).
 - [5] S.S. Kurennoy, Part. Acc. **39**, 1 (1992).
 - [6] R.L. Gluckstern, Phys. Rev. A **46**, 1106, 1110 (1992).
 - [7] See, for example, P.M. Morse and H. Feshbach, *Methods of Theoretical Physics*, McGraw Hill (New York, 1953).
 - [8] S.S. Kurennoy and G.V. Stupakov, Part. Acc. **45**, 95 (1994).
 - [9] R.L. Gluckstern, J.B.J. van Zeijts and B. Zotter, Phys. Rev. **E47**, 656 (1993).