

# HiFi-Stream: Streaming Speech Enhancement with Generative Adversarial Networks

Ekaterina Dmitrieva, and Maksim Kaledin.

**Abstract**—Speech Enhancement techniques have become core technologies in mobile devices and voice software simplifying downstream speech tasks. Still, modern Deep Learning (DL) solutions often require high amount of computational resources what makes their usage on low-resource devices challenging. We present HiFi-Stream, an optimized version of recently published HiFi++ model. Our experiments demonstrate that HiFiStream saves most of the qualities of the original model despite its size and computational complexity: the lightest version has only around 490k parameters which is 3.5x reduction in comparison to the original HiFi++ making it one of the smallest and fastest models available. The model is evaluated in streaming setting where it demonstrates its superior performance in comparison to modern baselines.

**Index Terms**—Audio denoising, audio processing, generative adversarial networks, speech enhancement, streaming audio processing.

## I. INTRODUCTION

Speech enhancement (SE) techniques are generally used as a preprocessing tool for speech downstream tasks such as speech recognition. The main goal of speech enhancement is to remove noise and reverberations coming from the actual environment where the audio is recorded. Mobile and wearable smart devices such as smartphones and smartwatches naturally face strongly corrupted speech as an audio input. Studies [1], [2] show that the quality of automatic speech recognition (ASR) solutions benefits from using an additional speech enhancement model making it an important part of speech processing pipeline. In the area of SE, the state-of-the-art Deep Learning (DL) approaches [3], [4], [5] demonstrated that DL can manage very hard audio conditions in speech enhancement and source separation problems. Nonetheless, the line of research in these models was mainly achieving quality at all costs resulting in dozens of millions parameters. On the other hand, such models require powerful computational resources which are unlikely to be placed in a mobile or wearable device. To get the scale, DEMUCS [3] hit the relevant realtime constraints as a result of significant optimization efforts. The architecture has around **60 M parameters** and requires **38.1 GMACs** (Multiply-ACcumulate operations) per second of audio in 16 kHz [6], [7]. The problem of constructing architectures for various speech processing tasks available on low-resource devices has become the focus of research efforts in recent years [8].

Generative Adversarial Networks (GANs) quickly showed their superior quality in text-to-speech problems [9], but

still the right-away application of GANs for SE problems [10], [11], [12] resulted in very computationally expensive models. Recently [6] it was shown that the number of parameters used in GANs for SE can be reduced more than 10 times suggesting that with more careful design there is an opportunity to propose even more efficient solution with almost the same performance on the benchmarks.

In our work we propose HiFi-Stream, an optimized version of HiFi++ [6] introducing structural and technical modifications. The experimental set up, pipeline and model configurations are given in the github repository: [https://github.com/KVDmitrieva/source\\_sep\\_hifi](https://github.com/KVDmitrieva/source_sep_hifi).

- 1) We show that the model can be reduced almost 3.5 times in parameters and around 30% in MACs making it one of the available quality-complexity trade-offs.
- 2) The experiments on VCTK [13] dataset in offline setting demonstrate that the proposed model does not lose much in performance in comparison to the original model.
- 3) We also investigate the performance of HiFiStream in an audio stream simulation where the audio is given in chunks. HiFi-Stream demonstrates superior quality to its direct competitors : HiFi++ [6] and FFC-SE [7]; both in performance and computational complexity without additional streaming training.

## II. RELATED WORK

Speech enhancement and speech separation methods generally can be classified into two branches of research. Time-frequency (TF) methods are based on the usage of the spectrograms produced by the Short-Time Fourier Transform (STFT). Models take a spectrogram as input and outputs the cleaned spectrogram which is transformed into a cleaned waveform via inverse STFT (iSTFT). The TF methods are represented in particular by [1], [4], [14]. Time-domain (TD) methods got their popularity just in recent years [3], [5], [15]–[17]. Most of these models by construction require millions of parameters, the most efficient of these are DPRNN models with around 2-6 M parameters [15]. For these reason in our research we focus on TF-methods.

Streaming processing presents additional constraints [8]. The first is computational complexity reflected by the number of parameters and processing time. The second is causality: the model is restricted to use only limited context. So, the researchers are focused on constructing streaming-aware versions of state-of-the-art solutions some of which include ReSepformer [18] and SkiM [19]. It was recently shown that

E. Dmitrieva is with HSE University, Russia, Moscow, 109028 11 Pokrovsky Bulvar (email: evdmitrieva\_3@edu.hse.ru).

M. Kaledin is with HSE University, Russia, Moscow, 109028 11 Pokrovsky Bulvar (email: mkaledin@hse.ru). Corresponding author.

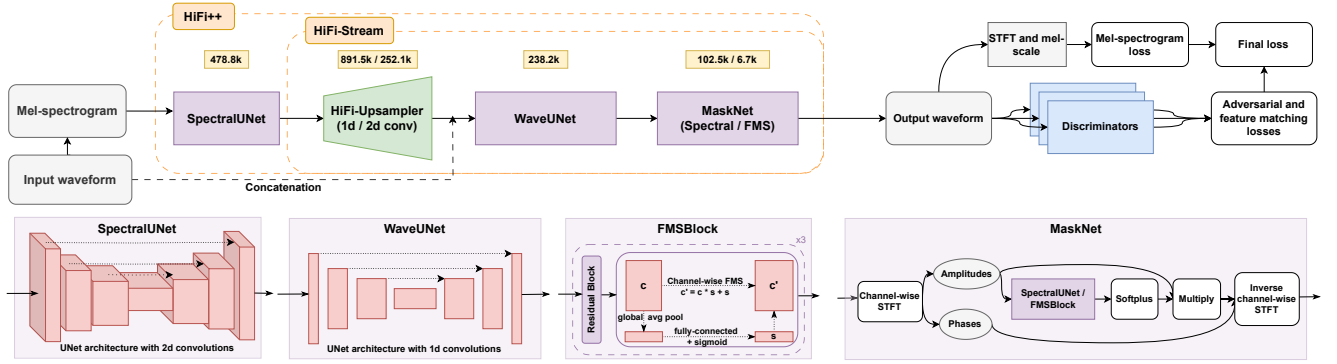

Fig. 1. HiFi++ and HiFi-Stream architectures: the new model reduced the number of parameters, got new MaskNet block, redesigned HiFi upsampler and removed SpectralUNet

regression transformer-based solutions can be implemented in low-resource setting but with considerable efforts invested into the attention mechanisms [8].

The generative look at the problem presented by SEGAN [10] later developed into HiFi-GAN solutions [11] and [12]. It was suggested to train and design the model as GAN where the generator predicts the clean waveform. This was reviewed in HiFi++ [6] with more structured design. The model achieved the baseline results despite significantly reduced model complexity. Several other solutions of the same scale were proposed later [7], [20], [21]. In [6], [7] the main goal was to reduce the model size but computational complexity was not addressed. Our aim is to improve also the computational complexity of the SE, and we improved the results of [6], [7] in this regard, see Fig. 3.

### III. METHODOLOGY

The problem of speech enhancement is to get an estimate  $\hat{x} \in \mathbb{R}^{N_{ch} \times T}$  of the clean speech signal  $x \in \mathbb{R}^{N_{ch} \times T}$  with  $N_{ch}$  channels from its corrupted representation

$$y = f \star x + \varepsilon,$$

where  $f \in \mathbb{R}^{N_{ch} \times k}$  represents an impulse response kernel (the effects of the environment acoustics, reverberation and recording device) which is convolved with the clean signal and  $\varepsilon \in \mathbb{R}^{N_{ch} \times T}$  is an additive noise component. In our work we consider a monaural problem, i.e. the signal has only one channel. Originally GAN approaches mostly [10], [11], [12] used time-domain approach requiring direct signal reconstruction. It turned out that such approaches typically have large number of parameters: one needs a sophisticated enough encoder and decoder to obtain a representative set of features from raw audio. So, HiFi++ [6] and our work in this aspect take a route of TF-methods rising from original vocoding applications [9]. Classic TF approaches usually propose to estimate a magnitude mask  $M(y) \in \mathbb{R}^{F \times M}$  with values from 0 to 1 for signal spectrogram  $s = STFT(y) \in \mathbb{C}^{F \times M}$  and then estimate the clean signal as

$$\hat{x} = iSTFT(M(y) \odot s).$$

In such a way, the phase component is bypassed to have a well-defined inverse STFT. On a high level, in HiFi++ the signal is first re-synthesized in several audio channels and then is processed by the masking pipeline producing the spectral mask.

The generator depicted on the Fig. 1 consists of several blocks: STFT-Mel transform, Spectral U-Net, HiFi, Wave U-Net and SpectralMaskNet. The idea is to train the generator to predict clean waveform and discriminator decides whether the audio is clean. We used the same loss construction and discriminators as in [6], [9] and focus our main efforts on the generator structure.

a) *Spectral U-Net*: The block is responsible for mel-spectrogram pre-processing and acts as feature transformer highlighting the important parts of the mel-spectrogram. We show that for mild noisy conditions the block is irrelevant, it is in line with the findings of [6] where the same was demonstrated for SE problem. So, we have removed the block in all our considered architectures resulting in reduction of 300k parameters.

b) *Improved HiFi block*: HiFi block is the largest core block in the model. When trained, it transforms mel-spectrogram  $m = Mel(s)$  of the signal  $x$  into multichannel audio  $x' \in \mathbb{R}^{n_{ch} \times T}$ . The channels can be interpreted as signal and noise layers very similar to those observed in the output of source separation [15]. We experimented with usage of 2D convolutions instead of 1D and varying parameters, which gave a drastic reduction in almost -400k parameters but in the same time GMACs became slightly higher with 2D convolutions. Still, the usage of 2D convolutions even with smaller kernel size increased the performance, since the model better exploits the spatio-temporal correlations in the spectrogram.

c) *Wave UNet*: The block is the main post-processing unit responsible for fixing the signal in time domain [6] by removing robo-voice artifacts typical for vocoding [9]. With the help of input waveform and multichannel vocoder output it effectively fixes the phase shifts. The Wave UNet design is taken from [6].

d) *Spectral Mask Net FMS*: SpectralMaskNet is another key component in the model since it generates the spectral

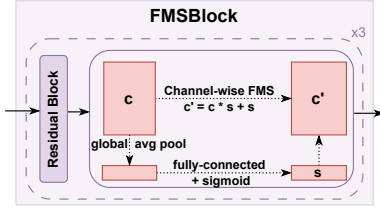

Fig. 2. FMS Block inspired by [23] takes the input tensor  $C \in \mathbb{R}^{F \times T}$ , computes the vector of scaling coefficients  $S \in \mathbb{R}^T$  and applies them filter-wise and computes the result via affine aggregation.

magnitude mask  $M(y)$ . The original HiFi++ used a U-Net processing unit which can be improved both in terms of parameters and computational complexity. The mask of gains is essentially a tensor of the same size as spectrogram where larger values depict higher amplitude. Such specification very natural for attention architectures [22] but it is known that despite attention design allows more expressive models, it is computationally expensive for streaming [8]. We came up with a cheaper attention alternative from RawNet2 [23] called Feature Map Scaling (FMS), known also as Squeeze-Excitation [24]. Instead of original UNet we used FMS Blocks with affine aggregation (see Fig. 2) in a ResNet structure. FMS acts as attention mechanism with reduced complexity. The usage of FMS ResNet gave 20x reduction in the MaskNet block.

#### IV. EXPERIMENTAL SETUP

##### A. Dataset

We used Valentini VCTK [13] dataset for experiments. The dataset is a selection of 30 speakers from the VoiceBank corpus with 28 and 2 speakers set for the training and test respectively. The original sample rate is 48 kHz, we resampled the audio to 16 kHz for comparison with other solutions. All audios were cut to 3 seconds as in [6].

In streaming scenario we used chunks of 4096 samples with no intersections. This gives us an estimate of streaming performance and measures the effect of limited context. The model separately processes all the chunks and the processed chunks are joined together to emulate the processing pipeline in audio stream.

For evaluation we used perceptual evaluation metrics: CSIG, CBAK, COVL, WB-PESQ, STOI, WV-MOS [6]. Also, we present objective evaluation metrics: SDR and SI-SDR. The key aspect of our research is model complexity, so we also demonstrate the complexity metrics: number of parameters and GMACs per second of audio measured with pytorch profiling library `thop`.

##### B. Training details

All models were trained for 150 epochs with learning rate  $2e-4$  on the given dataset with batch size 32 using AdamW optimizer (see the repository for the exact details). For HiFi++ we trained our own model (marked as *reprod.*) with the same computational budget but also added the metrics for the checkpoint given by [6].

## V. RESULTS

### A. Offline Comparison (Full Audio)

All the modifications were trained with the same computational resource, the results are depicted in the Table I. *HiFi++(reprod)* has lower metrics than presented in the repository due to the less training time invested. We compare the modified models to it to have the same training conditions. *HiFi w/o spec* acts as a starting point. The usage of 2D convolutions together with optimization of number of channels (*HiFi-2dMRF*) allowed a drastic reduction in parameters of HiFi Block resulting in almost 3x parameter reduction in comparison to *HiFi+w/o spec*. It presents the direction of smaller number of parameters but in cost of computational complexity.

The usage of FMS allows not only the reduced complexity and parameters but also better performance in terms of quality. *HiFi-fms* is essentially *HiFi++ w/o spec* with FMSBlock in place of MaskNet and *HiFi-fms+2dMRF* additionally uses 2D convolutions in HiFi MRF Blocks. The two models have their effect in comparison to *HiFi++(reprod.)* and *HiFi-2dMRF* depicting the effect of FMS Blocks. As we can see from the tables, the modifications with FMS despite the reduced complexity demonstrate relatively the same metrics or better than *HiFi w/o spec* and *HiFi++(reprod.)*.

Overall, *HiFi-Stream2D* model can be chosen as a small-size model and *HiFi-Stream* is the better option in terms of computational complexity, according to the MACs, see Fig.3.

We also compared our solutions to the available baselines including some recent GAN-based light-weight solutions. According to Table I, *HiFi-Stream* models demonstrate similar performance metrics with a slight drop in comparison to existing low-parameter baselines. In particular, the model reaches the same results as the lightest *FFC-AE-V0* with almost the same number of parameters but 2x reduced computational complexity.

### B. Streaming Comparison

We compare the stream-aware models in the streaming conditions (see Table II) without additional streaming training. It is notable that almost in all cases the quality declines in all metrics which is the effect of limited audio input and context. In comparison to published baselines *HiFi++* models with FMS blocks demonstrate their robustness in this regard showing slightly worse performance. It may be the case that due to the filter-wise scaling in FMS mechanism it better exploits short-time correlations while other models may require additional streaming finetuning to compensate for the lost global context.

## VI. CONCLUSION

Our results show that HiFi++ model can be optimized to become another GAN candidate to be the most optimal trade-off between complexity and quality. Among considered GAN baselines the proposed solutions are the best in terms of computational complexity. The achieved results suggest that the model is robust to limited context conditions and therefore can be used in SE streaming applications.

TABLE I

RESULTS ON VCTK [13] DATASET FOR DIFFERENT MODIFICATIONS OF HiFi++ AND OTHER SE MODELS (THE RESULTS MARKED WITH \* ARE TAKEN FROM THE PAPERS, OTHERWISE THE VALIDATION WAS OURS). THE TOP-2 VALUES IN TOP AND BOTTOM PARTS ARE PUT IN BOLD.

Model	WV-MOS	SI-SDR	SDR	STOI	PESQ	CSIG	CBAK	COVL	nParams	GMACs/sec
Ground Truth	4.500	-	-	1.000	4.640	5	5	5	-	-
Input	2.990	8.440	8.54	0.790	1.970	3.340	2.820	2.740	-	-
SEGAN [10]	-	-	-	-	2.160	3.480	2.940	2.80	-	-
MetricGAN+ [25]	3.913	8.162	14.734	0.853	<b>3.130</b>	3.971	3.123	3.549	2.700M	28.500
DEMUCS(non-caus.) [3]	<b>4.453</b>	<b>18.585</b>	<b>19.603</b>	<b>0.893</b>	3.015	4.348	<b>3.597</b>	<b>3.715</b>	30.100M	38.1
HiFiGAN-SE* [11]	-	-	-	-	2.940	4.070	3.070	3.490	-	-
HiFiGAN-2* [12]	-	-	-	-	<b>3.110</b>	<b>4.370</b>	3.540	3.740	-	-
FFC-AE-V0 [7]	4.339	16.313	17.291	0.865	2.669	4.061	3.296	3.373	<b>0.422M</b>	<b>4.064</b>
FFC-AE-V1 [7]	4.402	16.899	17.484	<b>0.893</b>	2.868	4.238	3.497	3.573	<b>1.665M</b>	15.672
FFC-UNet [7]	<b>4.421</b>	17.851	18.702	<b>0.894</b>	2.962	<b>4.349</b>	<b>3.510</b>	<b>3.682</b>	7.673M	35.552
HiFi++ [6]	4.385	<b>17.954</b>	<b>18.936</b>	0.890	2.906	4.271	3.483	3.609	1.706M	<b>2.746</b>
HiFi++(reprod.)	<b>4.314</b>	13.400	15.661	<b>0.866</b>	2.595	3.998	<b>3.173</b>	3.305	1.617M	2.096
HiFi w/o spec	4.278	12.808	<b>16.155</b>	<b>0.873</b>	<b>2.703</b>	<b>4.094</b>	3.166	<b>3.413</b>	1.356M	2.007
HiFi-2dMRF	4.130	13.455	15.812	0.865	2.466	3.865	3.075	3.172	<b>0.677M</b>	2.084
HiFi-fms (HiFi-Stream)	<b>4.320</b>	<b>14.067</b>	15.924	0.865	<b>2.701</b>	<b>4.031</b>	<b>3.220</b>	<b>3.372</b>	1.174M	<b>1.895</b>
HiFi-fms+2dMRF (HiFi-Stream2D)	4.312	<b>14.762</b>	<b>17.213</b>	0.864	2.652	4.027	3.167	3.345	<b>0.497M</b>	<b>1.973</b>

TABLE II

STREAMING EVALUATION RESULTS ON VCTK [13] DATASET FOR DIFFERENT MODIFICATIONS OF HiFi++ AND OTHER SE MODELS. THE TOP VALUES IN TOP AND BOTTOM PARTS ARE PUT IN BOLD.

Model	WV-MOS	SI-SDR	SDR	STOI	PESQ	CSIG	CBAK	COVL
Ground Truth	4.500	-	-	1.000	4.640	5	5	5
Input	2.990	8.440	8.54	0.790	1.970	3.340	2.820	2.740
DEMUCS(caus.dns) [3]	<b>4.600</b>	<b>17.804</b>	<b>19.310</b>	0.881	<b>2.657</b>	3.823	<b>3.231</b>	<b>3.236</b>
FFC-AE-V0 [7]	4.209	12.664	13.820	0.789	1.996	3.502	2.807	2.742
FFC-AE-V1 [7]	4.365	15.147	15.806	0.860	2.424	3.906	3.214	3.172
FFC-UNet [7]	4.378	15.683	16.467	0.861	2.452	<b>3.974</b>	3.225	3.222
HiFi++ [6]	4.263	14.669	15.264	<b>0.930</b>	2.365	3.838	3.162	3.103
HiFi++(reprod.)	4.253	13.014	15.383	0.841	2.263	<b>3.715</b>	2.917	<b>2.992</b>
HiFi w/o spec	4.059	11.839	14.746	0.791	1.932	3.200	2.671	2.559
HiFi-2dMRF	3.995	12.771	14.861	0.806	1.931	3.259	2.726	2.587
HiFi-fms (HiFi-Stream)	4.247	13.328	15.123	0.845	<b>2.295</b>	3.667	2.860	2.981
HiFi-fms+2dMRF (HiFi-Stream2D)	<b>4.296</b>	<b>14.189</b>	<b>16.328</b>	<b>0.847</b>	2.286	3.680	<b>2.925</b>	2.982

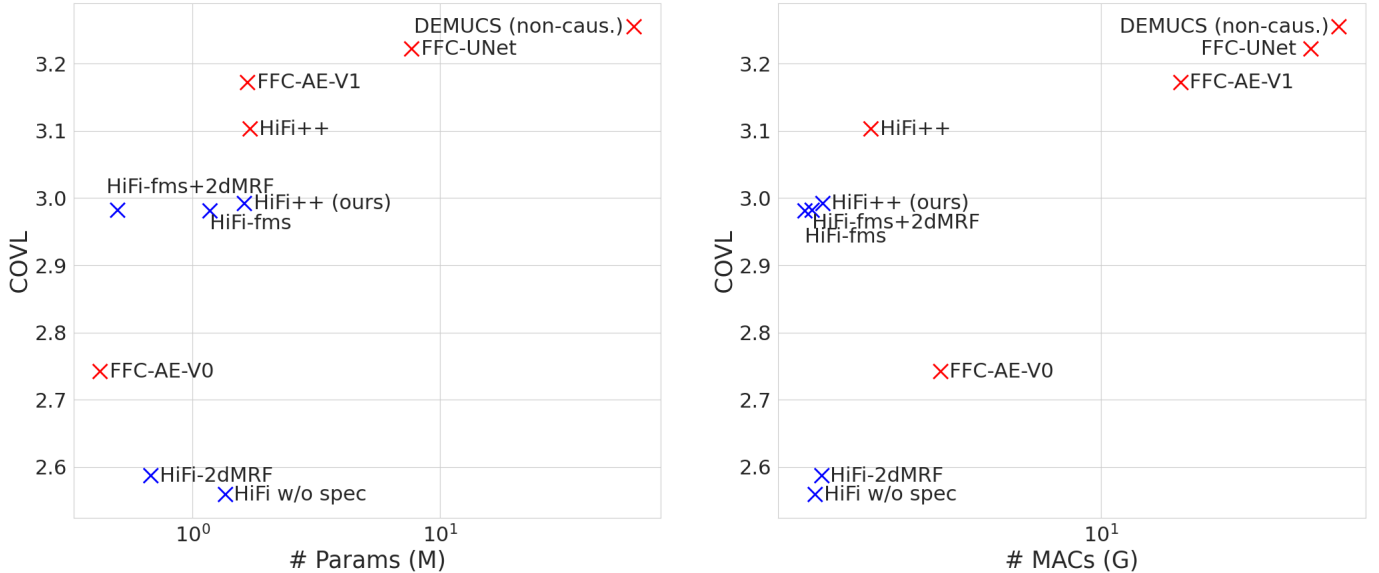

Fig. 3. Performance metric (COVL) against the computational complexity and number of parameters for compared models (streaming evaluation)

## ACKNOWLEDGMENT

This research was supported in part through computational resources of HPC facilities at HSE University.

## REFERENCES

- [1] R. Rikhye, Q. Wang, Q. Liang, Y. He, and I. McGraw, "Multi-user voicefilter-lite via attentive speaker embedding," in *2021 IEEE Auto-*

- matic Speech Recognition and Understanding Workshop (ASRU)*, 2021, pp. 275–282.
- [2] Q. Wang, I. L. Moreno, M. Saglam, K. Wilson, A. Chiao, R. Liu, Y. He, W. Li, J. Pelecanos, M. Nika, and A. Gruenstein, “VoiceFilter-Lite: Streaming Targeted Voice Separation for On-Device Speech Recognition,” in *Proc. Interspeech 2020*, 2020, pp. 2677–2681.
- [3] A. Defossez, G. Synnaeve, and Y. Adi, “Real time speech enhancement in the waveform domain,” in *Interspeech*, 2020.
- [4] Y. Hu, Y. Liu, S. Lv, M. Xing, S. Zhang, Y. Fu, J. Wu, B. Zhang, and L. Xie, “DCCRN: Deep Complex Convolution Recurrent Network for Phase-Aware Speech Enhancement,” in *Proc. Interspeech 2020*, 2020, pp. 2472–2476.
- [5] C. Subakan, M. Ravanelli, S. Cornell, M. Bronzi, and J. Zhong, “Attention is all you need in speech separation,” in *ICASSP 2021 - 2021 IEEE International Conference on Acoustics, Speech and Signal Processing (ICASSP)*, 2021, pp. 21–25.
- [6] P. Andreev, A. Alanov, O. Ivanov, and D. Vetrov, “Hifi++: A unified framework for bandwidth extension and speech enhancement,” in *ICASSP 2023 - 2023 IEEE International Conference on Acoustics, Speech and Signal Processing (ICASSP)*, 2023, pp. 1–5.
- [7] I. Shchekotov, P. K. Andreev, O. Ivanov, A. Alanov, and D. Vetrov, “FFC-SE: Fast Fourier Convolution for Speech Enhancement,” in *Proc. Interspeech 2022*, 2022, pp. 1188–1192.
- [8] C.-H. Wu and T.-S. Chang, “A low-power streaming speech enhancement accelerator for edge devices,” *IEEE Open Journal of Circuits and Systems*, vol. 5, pp. 128–140, 2024.
- [9] J. Kong, J. Kim, and J. Bae, “Hifi-gan: generative adversarial networks for efficient and high fidelity speech synthesis,” in *Proceedings of the 34th International Conference on Neural Information Processing Systems*, ser. NIPS ’20. Red Hook, NY, USA: Curran Associates Inc., 2020.
- [10] S. Pascual, A. Bonafonte, and J. Serra, “SEGAN: Speech Enhancement Generative Adversarial Network,” in *Proc. Interspeech 2017*, 2017, pp. 3642–3646.
- [11] J. Su, Z. Jin, and A. Finkelstein, “HiFi-GAN: High-Fidelity Denoising and Dereverberation Based on Speech Deep Features in Adversarial Networks,” in *Proc. Interspeech 2020*, 2020, pp. 4506–4510.
- [12] —, “HiFi-GAN-2: Studio-quality speech enhancement via generative adversarial networks conditioned on acoustic features,” in *WASPAA 2021*, Oct. 2021.
- [13] C. Valentini-Botinhao, X. Wang, S. Takaki, and J. Yamagishi, “Speech Enhancement for a Noise-Robust Text-to-Speech Synthesis System Using Deep Recurrent Neural Networks,” in *Proc. Interspeech 2016*, 2016, pp. 352–356.
- [14] J. Chen, Z. Wang, D. Tuo, Z. Wu, S. Kang, and H. Meng, “Fullsubnet+: Channel attention fullsubnet with complex spectrograms for speech enhancement,” in *ICASSP 2022 - 2022 IEEE International Conference on Acoustics, Speech and Signal Processing (ICASSP)*, 2022, pp. 7857–7861.
- [15] Y. Luo, Z. Chen, and T. Yoshioka, “Dual-path rnn: Efficient long sequence modeling for time-domain single-channel speech separation,” in *ICASSP 2020 - 2020 IEEE International Conference on Acoustics, Speech and Signal Processing (ICASSP)*, 2020, pp. 46–50.
- [16] Y. Luo and N. Mesgarani, “Conv-tasnet: Surpassing ideal time–frequency magnitude masking for speech separation,” *IEEE/ACM Trans. Audio, Speech and Lang. Proc.*, vol. 27, no. 8, p. 1256–1266, aug 2019. [Online]. Available: <https://doi.org/10.1109/TASLP.2019.2915167>
- [17] K. Wang, B. He, and W.-P. Zhu, “Tstnn: Two-stage transformer based neural network for speech enhancement in the time domain,” in *ICASSP 2021 - 2021 IEEE International Conference on Acoustics, Speech and Signal Processing (ICASSP)*, 2021, pp. 7098–7102.
- [18] L. Della Libera, C. Subakan, M. Ravanelli, S. Cornell, F. Lepoutre, and F. Grondin, “Resource-efficient separation transformer,” in *ICASSP 2024 - 2024 IEEE International Conference on Acoustics, Speech and Signal Processing (ICASSP)*, 2024, pp. 761–765.
- [19] C. Li, L. Yang, W. Wang, and Y. Qian, “Skim: Skipping memory lstm for low-latency real-time continuous speech separation,” in *ICASSP 2022 - 2022 IEEE International Conference on Acoustics, Speech and Signal Processing (ICASSP)*, 2022, pp. 681–685.
- [20] J. Liu and X. Zhang, “Iccrn: Inplace cepstral convolutional recurrent neural network for monaural speech enhancement,” in *ICASSP 2023 - 2023 IEEE International Conference on Acoustics, Speech and Signal Processing (ICASSP)*, 2023, pp. 1–5.
- [21] C. Zhao, S. He, and X. Zhang, “Sicrn: Advancing speech enhancement through state space model and inplace convolution techniques,” in *ICASSP 2024 - 2024 IEEE International Conference on Acoustics, Speech and Signal Processing (ICASSP)*, 2024, pp. 10506–10510.
- [22] A. Vaswani, N. Shazeer, N. Parmar, J. Uszkoreit, L. Jones, A. N. Gomez, L. u. Kaiser, and I. Polosukhin, “Attention is all you need,” in *Advances in Neural Information Processing Systems*, I. Guyon, U. V. Luxburg, S. Bengio, H. Wallach, R. Fergus, S. Vishwanathan, and R. Garnett, Eds., vol. 30. Curran Associates, Inc., 2017. [Online]. Available: [https://proceedings.neurips.cc/paper\\_files/paper/2017/file/3f5ee243547dee91fbd053c1c4a845aa-Paper.pdf](https://proceedings.neurips.cc/paper_files/paper/2017/file/3f5ee243547dee91fbd053c1c4a845aa-Paper.pdf)
- [23] J. weon Jung, S. bin Kim, H. jin Shim, J. ho Kim, and H.-J. Yu, “Improved rawnet with feature map scaling for text-independent speaker verification using raw waveforms,” in *Interspeech 2020*, 2020, pp. 1496–1500.
- [24] J. Hu, L. Shen, and G. Sun, “Squeeze-and-excitation networks,” in *2018 IEEE/CVF Conference on Computer Vision and Pattern Recognition*, 2018, pp. 7132–7141.
- [25] S.-W. Fu, C. Yu, T.-A. Hsieh, P. Plantinga, M. Ravanelli, X. Lu, and Y. Tsao, “MetricGAN+: An Improved Version of MetricGAN for Speech Enhancement,” in *Proc. Interspeech 2021*, 2021, pp. 201–205.