

# QKD security proofs for decoy-state BB84: protocol variations, proof techniques, gaps and limitations

Devashish Tupkary,<sup>\*</sup> Ernest Y.-Z. Tan,<sup>†</sup> Shlok Nahar,<sup>‡</sup> Lars Kamin,<sup>§</sup> and Norbert Lütkenhaus<sup>¶</sup>  
*Institute for Quantum Computing and Department of Physics and Astronomy,  
University of Waterloo, Waterloo, Ontario, Canada, N2L 3G1*

We discuss the status of security proofs for practical decoy-state Quantum Key Distribution using the BB84 protocol, pertaining to optical implementations using weak coherent pulses and threshold photo-detectors. Our focus is on the gaps in the existing literature. Gaps might result, for example, from a mismatch of protocol detail choices and proof technique elements, from proofs relying on earlier results that made different assumptions, or from protocol choices that do not consider real-world requirements. While substantial progress has been made, our overview draws attention to the details that still require our attention.

arXiv:2502.10340v1 [quant-ph] 14 Feb 2025

---

<sup>\*</sup> [djtupkary@uwaterloo.ca](mailto:djtupkary@uwaterloo.ca)

<sup>†</sup> [yzetan@uwaterloo.ca](mailto:yzetan@uwaterloo.ca)

<sup>‡</sup> [sanahar@uwaterloo.ca](mailto:sanahar@uwaterloo.ca)

<sup>§</sup> [lars.kamin@outlook.com](mailto:lars.kamin@outlook.com)

<sup>¶</sup> [lutkenhaus.office@uwaterloo.ca](mailto:lutkenhaus.office@uwaterloo.ca)

## 1. Executive summary

Quantum Key Distribution (QKD) is a maturing technology. From its initial conception in 1984 with the Bennett-Brassard BB84 protocol, it entered the era of experimental implementation, and soon thereafter the commercial stage as well. On the protocol side, important steps in this journey were the introduction of weak laser pulses and the introduction of the decoy state protocols. On the theory side, important steps were the development of a clean definition of the security notion of QKD protocols, and the development of proof techniques that applied initially to asymptotic security evaluations, but also to more complete proofs for finite block length of signals. Another important aspect was the consideration of the quantum optical nature of implementations that relies on optical modes rather than abstract qubits as fundamental objects of the description.

We are now in a situation where QKD appears solidly established, with well-studied protocols like the decoy-state BB84 protocol with weak coherent laser pulses. As the field is starting to define the certification environment of this application, it appears that there are many choices to be made in defining a precise QKD protocol. Moreover, full security proofs need to account for the precise choice made. Historically, proof techniques have evolved in myriad ways, with a literature that is often a patchwork of partial results. While each patch solves an important aspect of a full security proof, the patches do not necessarily fit perfectly together, either because of a mismatch in the assumptions made in various works, or because of the protocol choices that each result is applicable to.

This report starts by giving an overview of the often detailed protocol choices that are being made in different versions of the decoy-state BB84 protocol, and how those choices relate to the various proof technique elements that have been described in the literature. Based on this outline, we then give an overview of the various concepts needed for rigorous QKD security proof, before discussing common gaps and misconceptions present in the literature. Our analysis sharpens the awareness of potential pitfalls and of the level of detail that is necessary to define a QKD protocol, and to deliver a valid complete security proof. Finally, we review several important works on complete security proofs for decoy-state BB84, and list the achievements, limitations, and gaps in each of these works. In our analysis, we broadly classify security proofs into the following categories (see Section 6): entropic uncertainty relations (EUR) based proofs, phase error correction based proofs, proofs utilizing the postselection technique followed by an IID security analysis, and proofs based on the entropy accumulation theorem (EAT) or generalized entropy accumulation theorem (GEAT).

In the end, we need security proofs that

- specify complete protocols that are relevant to practical implementations,
- specify the exact assumptions about the devices used in QKD,
- specify the exact security definition,
- and deliver a mathematical proof that the given protocol with the given assumptions satisfies the exact security definition with given security parameters.

Moreover, the proof should be such that

- the validity of the proof can be verified by mathematically trained evaluators,
- the achievable secure key generation rate should be practically relevant, not unnecessarily restricted by proof technique or protocol choices,
- the proof is as modular as possible, so that it can be confidently modified to protocol choices other than the originally specified ones,
- use proof techniques that allow the extension of the protocol security to implementation security, where implementation imperfections can be taken into account.

From our overview it will become clear that currently no single publication satisfies all these criteria [1], though a tremendous progress of knowledge and insight has been achieved over the last decades. Thus, the task of assembling the knowledge to provide such a protocol definition and associated security proof is still left open.

## 2. Definitions and Notation

### 2.1. Concepts from quantum information theory

We do not aim to give a detailed introduction to the framework of quantum information theory within this work. However, we will need to refer to a number of concepts and properties from that framework. Here, we shall briefly outline the qualitative properties of some such concepts, deferring detailed definitions to suitable references — see for instance Refs. [2, 3].

**Quantum states.** A quantum state describing some register(s)  $A$  is formalized as a positive semidefinite operator  $\rho_A$ , and we say that it is **normalized** if it has trace 1, while it is **subnormalized** if its trace is at most 1 [3]. However, we highlight that in this work we will mostly only refer to normalized states, only considering subnormalized states if explicitly specified. We may omit the subscript specifying the register(s) if it is clear from context.

**Quantum conditional states.** We will also often need to refer to the notion of a quantum state conditioned on some event. We defer the formal definitions to e.g. Ref. [4, Sec. 2.2], here simply noting that this notion is formalized by requiring that the quantum state contains a classical register that determines whether the event occurred. Note that the conditional state can be defined in either a normalized or subnormalized manner — the two possibilities are often denoted as  $\rho_{A|\Omega}$  and  $\rho_{A\wedge\Omega}$  respectively (given an event  $\Omega$ ), though this work will mainly focus on normalized conditional states, as mentioned above.

**Trace distance.** The trace distance is a metric on the set of quantum states, which we shall denote as  $d(\rho, \sigma)$  for any pair of quantum states  $\rho, \sigma$ . Here we follow the definition in e.g. Ref. [3], which covers subnormalized states. Critically, trace distance has an operational implication in terms of quantifying how well the states can be distinguished by *any* possible physical process, without computational limitations.

**Entropies.** In this work, we will refer to several notions of (conditional) entropy of a state  $\rho_{AB}$ , following the definitions in e.g. Ref. [3]. We highlight the following in particular:

- Von Neumann entropy  $H(A|B)_\rho$
- Min-entropy  $H_{\min}(A|B)_\rho$
- Smooth min-entropy  $H_{\min}^{\bar{\epsilon}}(A|B)_\rho$

Informally, these entropies can be viewed as describing how much “uncertainty” there is about the register  $A$  from the perspective of a party holding register  $B$ . In particular, if  $A$  is classical, the min-entropy  $H_{\min}(A|B)_\rho$  has an operational interpretation in terms of how well the value of  $A$  can be guessed given access to the register  $B$ ; the smooth min-entropy  $H_{\min}^{\bar{\epsilon}}(A|B)_\rho$  is an extension of this concept that considers states in a “neighbourhood” of  $\rho$ . We will also briefly mention Rényi entropies (as described in e.g. Ref. [3]) at some points, though we highlight that there are multiple distinct definitions of the concept, and when writing a security proof it is important to specify which definition is being used.

### 2.2. Classes of QKD protocols

In this work, we will mostly focus on what are known as **prepare-and-measure** (PM) QKD protocols, in which Alice prepares quantum states and sends them to Bob, who measures them. This is to be contrasted with **entanglement-based** (EB) QKD protocols, in which an entangled quantum state is shared between Alice and Bob, who measure their respective shares of the state.

Furthermore, in this work we will often separately discuss the following classes of QKD protocols:

- **Fixed-length protocols:** This refers to protocols that make a binary decision of whether to accept or abort, and output a final key of some fixed length  $\ell_{\text{fixed}}$  (determined before the protocol begins) when they accept.
- **Variable-length protocols:** This refers to protocols where the length of the final key can be variable (possibly including zero), depending on the observations made during the protocol.

In principle, fixed-length protocols can in fact be viewed as a special case of variable-length protocols, where the only possible final key lengths are 0 or the predetermined value  $\ell_{\text{fixed}}$ . The security definitions we present below for

fixed-length and variable-length protocols are also all consistent with this interpretation. However, in this work it will often be convenient to discuss the two classes separately, as some proof techniques are better suited for fixed-length protocols specifically.

### 2.3. Security definitions

Current security proofs in QKD are mostly centred around a particular security definition involving trace distance. The justification behind this choice of security definition is that it yields **composable security**, which informally means that the keys generated from a QKD protocol can be safely used as part of a larger protocol. We defer a detailed discussion of this point to<sup>1</sup> Refs. [5, 6]; here, we simply restate the security definitions from those works.

**Definition 2.1.** (Security)<sup>2</sup> Let  $\varepsilon^{\text{secure}} \in [0, 1]$ . Consider a QKD protocol such that at the end of the protocol, Alice and Bob hold final keys  $K_A$  and  $K_B$  respectively, while Eve holds a final side-information register  $E_{\text{fin}}$ . Let  $\tau_{K_A K_B}^\ell := \sum_{k \in \{0,1\}^\ell} \frac{1}{2^\ell} |kk\rangle\langle kk|_{K_A K_B}$  denote a maximally correlated key of length  $\ell$  across registers  $K_A K_B$ .

For a fixed-length protocol, we say it is  $\varepsilon^{\text{secure}}$ -secure if the output state always satisfies

$$\Pr[\Omega_{\text{acc}}] d\left(\rho_{K_A K_B E_{\text{fin}}|\Omega_{\text{acc}}}, \tau_{K_A K_B}^{\ell_{\text{fixed}}} \otimes \rho_{E_{\text{fin}}|\Omega_{\text{acc}}}\right) \leq \varepsilon^{\text{secure}}, \quad (1)$$

where  $\Omega_{\text{acc}}$  denotes the event that the protocol accepts.

For a variable-length protocol, we say it is  $\varepsilon^{\text{secure}}$ -secure if the output state always satisfies

$$\sum_{\ell} \Pr[\Omega_{\ell}] d\left(\rho_{K_A K_B E_{\text{fin}}|\Omega_{\ell}}, \tau_{K_A K_B}^{\ell} \otimes \rho_{E_{\text{fin}}|\Omega_{\ell}}\right) \leq \varepsilon^{\text{secure}}, \quad (2)$$

where  $\Omega_{\ell}$  denotes the event that the protocol produces a key of length  $\ell$ .

**Remark 2.1.** We emphasize that the security definition does not state that the trace-distance term in Eq. (1) (for fixed-length protocols) is itself upper bounded by  $\varepsilon^{\text{secure}}$ . This is because such an upper bound simply does not hold in general; in particular, it is usually straightforward to construct attacks such that

$$d\left(\rho_{K_A K_B E_{\text{fin}}|\Omega_{\text{acc}}}, \tau_{K_A K_B}^{\ell_{\text{fixed}}} \otimes \rho_{E_{\text{fin}}|\Omega_{\text{acc}}}\right) \gg \varepsilon^{\text{secure}}, \quad (3)$$

as we discuss later in Section 4.5. Similarly, for variable-length protocols, one cannot claim that the individual trace-distance terms in Eq. (2) are all upper bounded by  $\varepsilon^{\text{secure}}$ .

Critically, however, Definition 2.1 is already sufficient to ensure composable security, and hence this fact does not affect the composable security of QKD protocols. We defer to Refs. [5, 6] for more extensive discussion of this point.

As described in Refs. [5, 6], it is often convenient to instead study a pair of simpler conditions, referred to as **correctness** and **secrecy**:<sup>3</sup>

**Definition 2.2.** (Correctness and secrecy) Let  $\varepsilon^{\text{correct}}, \varepsilon^{\text{secret}} \in [0, 1]$ . Consider a QKD protocol such that at the end of the protocol, Alice and Bob hold final keys  $K_A$  and  $K_B$  respectively, while Eve holds a final side-information register  $E_{\text{fin}}$ . Let  $\omega_{K_A}^\ell := \sum_{k \in \{0,1\}^\ell} \frac{1}{2^\ell} |k\rangle\langle k|_{K_A}$  denote a uniformly random key of length  $\ell$  on register  $K_A$ .

For a fixed-length protocol, we say it is  $\varepsilon^{\text{correct}}$ -correct if the output state always satisfies

$$\Pr[K_A \neq K_B \text{ and protocol accepts}] \leq \varepsilon^{\text{correct}}, \quad (4)$$

and we say it is  $\varepsilon^{\text{secret}}$ -secret if the output state always satisfies

$$\Pr[\Omega_{\text{acc}}] d\left(\rho_{K_A E_{\text{fin}}|\Omega_{\text{acc}}}, \omega_{K_A}^{\ell_{\text{fixed}}} \otimes \rho_{E_{\text{fin}}|\Omega_{\text{acc}}}\right) \leq \varepsilon^{\text{secret}}, \quad (5)$$

where  $\Omega_{\text{acc}}$  denotes the event that the protocol accepts.

<sup>1</sup> These works present somewhat different perspectives on composable security, but they coincide in terms of the desired security definitions in terms of trace distance.

<sup>2</sup> This property is sometimes instead referred to as **soundness**, for instance in Ref. [6].

<sup>3</sup> The choice to use  $K_A$  rather than  $K_B$  in the secrecy definition is essentially arbitrary; analogous results can be derived under either choice.

For a variable-length protocol, we say it is  $\varepsilon^{\text{correct}}$ -correct if the output state always satisfies

$$\Pr[K_A \neq K_B \text{ and final key length is nonzero}] \leq \varepsilon^{\text{correct}}, \quad (6)$$

and we say it is  $\varepsilon^{\text{secret}}$ -secret if the output state always satisfies

$$\sum_{\ell} \Pr[\Omega_{\ell}] d(\rho_{K_A E_{\text{fin}}|\Omega_{\ell}}, \omega_{K_A}^{\ell} \otimes \rho_{E_{\text{fin}}|\Omega_{\ell}}) \leq \varepsilon^{\text{secret}}, \quad (7)$$

where  $\Omega_{\ell}$  denotes the event that the protocol produces a key of length  $\ell$ .

Importantly, correctness and secrecy together imply security, as shown in Refs. [5, 6]:

**Theorem 2.1.** [6, Theorem 2] *If a QKD protocol is  $\varepsilon^{\text{correct}}$ -correct and  $\varepsilon^{\text{secret}}$ -secret, then it is  $(\varepsilon^{\text{correct}} + \varepsilon^{\text{secret}})$ -secure.*

Hence to prove a protocol satisfies the security definition, it suffices to show it satisfies the correctness and secrecy definitions, and add the corresponding parameters.

#### 2.4. Completeness and expected key rate

The above definitions suffice to formulate what it means for a QKD protocol to be “secure”, in the sense that it can be “safely” used as part of a larger protocol. However, they do not fully address the question of whether the protocol is “useful”, informally speaking. For instance, observe that if a fixed-length protocol has a high output key length  $\ell_{\text{fixed}}$  when it accepts, but almost never actually accepts, then this would not seem to be a very practically useful protocol.<sup>4</sup> More technically, inspecting Definition 2.1 shows that any fixed-length protocol in which the accept probability is *never* greater than  $\varepsilon^{\text{secure}}$  would trivially fulfill that definition, but this would not seem to be very useful either.

To address this point, one usually imposes a condition that the protocol can perform “nontrivially” in at least some circumstances. Typically, this is done by specifying some assumed **honest behaviour** of the protocol when Eve does not attempt an attack (note that this behaviour may still have some forms of noise or loss). For prepare-and-measure protocols, this is sometimes referred to as the (honest) **channel model**, as it mostly focuses on describing how the quantum channel between Alice and Bob (see Section 3) behaves in the honest case.

Given such an honest behaviour or channel model, there are two common approaches to formalize the idea that the protocol has “nontrivial” performance:

**Completeness.** This approach is only relevant to fixed-length protocols, and is described in e.g. Ref. [6]. For  $\varepsilon^{\text{com}} \in [0, 1]$ , we say that a fixed-length protocol is  $\varepsilon^{\text{com}}$ -**complete** if the probability of it aborting in the honest case is at most  $\varepsilon^{\text{com}}$ . Requiring that  $\varepsilon^{\text{com}}$  is small will ensure the protocol is “nontrivial” in that it has high probability of accepting (thus generating a key) in the honest case, at least.

**Expected key rates.** This approach can be used for both fixed-length and variable-length protocols. The idea is to compute the *expected value* of the key rate under the honest behaviour, which serves as a way to quantify how much key we expect to get in that case. In particular, for fixed-length protocols the expected key rate is simply  $\Pr[\Omega_{\text{acc}}] \ell_{\text{fixed}}$  (with  $\Pr[\Omega_{\text{acc}}]$  computed on the honest behaviour), which is lower than the key length  $\ell_{\text{fixed}}$  it produces when it accepts.

In light of the above, we highlight that to quantify the performance of a fixed-length protocol, it does *not* suffice to focus solely on the key length  $\ell_{\text{fixed}}$  it produces when it accepts, since that does not address the question of whether it is likely to ever accept. Instead, one has to account for the accept probability in the honest case in some form, for instance via the completeness parameter or the expected key rate.

**Remark 2.2.** *We emphasize that the assumed honest behaviour is only relevant for discussing completeness or expected key rates. It does not affect in any way the security properties discussed in Section 2.3, which are completely independent of this honest behaviour.*

---

<sup>4</sup> While this might perhaps appear artificial, we highlight that if the conditions for the accept/abort decision are not designed with sufficient “tolerance”, then one would indeed end up with a protocol that almost always aborts. Some early works in QKD inadvertently constructed such protocols by having overly restrictive accept conditions; we briefly discuss this in Section 5.1 under the term “unique-acceptance”.

### 3. Structural elements of QKD protocols

For a PM-QKD protocol, it is typically assumed that Alice and Bob have access to the following resources:

- Ideal RNG devices (“locally” for each party, i.e. they do not have access to shared randomness).
- An “untrusted” quantum channel, where an eavesdropper Eve can freely manipulate states sent along the channel.
- An authenticated public classical channel, where Eve can see all messages sent along the channel, but cannot modify the messages without causing the authentication procedure to abort.<sup>5</sup> Note that this is a weaker property than the claim that Eve *cannot* modify the messages, and hence some care is needed when analyzing this channel in the security proof. We discuss this further in Section 5.2.
- A tacit assumption in many QKD protocols is the existence of reliable time synchronization or time-tagging mechanisms for messages. This ensures that all parties agree on when specific phases of the protocol end and others begin, and that the sequence of messages is clear and lost messages are identified.

We now lay out a rough outline of the structure that most PM-QKD protocols follow. In the outline, all quantum states are implicitly meant to be sent using the “open” quantum channel, while all classical communication takes place over the authenticated public classical channel, with the protocol aborting whenever the authentication aborts.

1. **State preparation and measurement:** Alice generates states (referred to as **signal states**) over some number of rounds, and sends them to Bob, who measures them. Alice records her signal state choices in a classical register, and similarly Bob records his measurement outcomes (and basis choices, if relevant) in another classical register. We refer to these registers as Alice and Bob’s **raw data**.
2. **Public announcements and processing:** Alice and Bob perform various classical operations on the data gathered in the previous steps, usually assisted by announcing some classical values computed from that data. For instance, a common procedure in this step is **sifting**, in which Alice and Bob announce information such as their basis choices, then use this to erase or discard data from some rounds, such as rounds where they had different basis choices. They may also announce some data for use in later steps such as the acceptance test. At the end of this step, one of the parties holds a string **S** that they will use as the input to the final privacy amplification step (see below), which we will refer to as the **pre-amplification string**. Note that this pre-amplification string **S** will not be modified in any way until the privacy amplification step.
3. **Acceptance test or variable-length decision:** The procedure implemented here depends on whether it is a fixed-length protocol, which outputs a key of fixed length whenever it accepts, or a variable-length protocol, which may output a key of variable length. For the former, this step consists of an **acceptance test** in which Alice and Bob decide whether to abort the protocol. (Note that the protocol may also abort in some later steps as well, such as error verification; see below.) For the latter, this step consists of a **variable-length decision** where Alice and Bob choose the length of final key that they will output (this length may be zero, effectively corresponding to an abort). They may also choose the parameters of their error correction protocol at this stage.
4. **Error correction and error verification:** In **error correction**, the parties perform some further public communication, such that the party not already holding a pre-amplification string can produce their own pre-amplification string, which should ideally match the other’s with high probability.<sup>6</sup> This may be followed by **error verification**, where Alice and Bob attempt to check whether their pre-amplification strings match, and abort if the check fails.
5. **Privacy amplification:** If the protocol has not aborted thus far, Alice and Bob finally perform a procedure that generates a final key from their pre-amplification strings. Most commonly, this is implemented by applying a hashing procedure to those strings, though other procedures (in general referred to as **randomness extraction**) are possible.

In the following sections, we give qualitative descriptions of the purpose of each step, then elaborate further on details and possible variations. There is some flexibility in the ordering of various steps in the outline; we briefly mention alternative possibilities as they arise in the subsequent discussions.

<sup>5</sup> Note that such a channel can be constructed from an unauthenticated public classical channel together with a short pre-shared key by using Wegman-Carter authentication [7], which has information-theoretic composable security even against quantum adversaries [8]. Hence in principle, this resource requirement could be replaced with an unauthenticated public classical channel and a short pre-shared key. However, we will not focus on this within this work.

<sup>6</sup> Some earlier works described this step as “information reconciliation” and allowed *both* parties to modify their data to attempt to obtain some common shared string. For this work, we choose to instead group any such operations into the processing step, and hence there is no loss of generality in only having one party aim to match the other party’s pre-amplification string in this step.

### 3.1. State preparation and measurement

For brevity, we may sometimes also refer to this as the prepare-and-measure step. This step allows Alice and Bob to generate the raw data that will eventually be distilled into a secret key over the subsequent steps, as well as attempt to detect whether Eve is eavesdropping. It consists of a sequence of rounds in which Alice prepares signal states to send to Bob, who in turn measures them. Alice’s record of her choices of signal states, and Bob’s record of his measurement outcomes (and basis choices — see Section 3.1.1 below), will serve as their raw data for the subsequent steps. We now elaborate further on various aspects of this step.

#### 3.1.1. Active or passive basis choices

Broadly speaking, there are two possible options for how Bob performs his measurements. One option is referred to as **active** basis choice, in which Bob uses his RNG device to choose the basis used for measuring. The other option is referred to as **passive** basis choice, in which Bob’s measurement device itself determines the basis to measure in, for instance via a beamsplitter. Different proof techniques may be needed to handle each case.

#### 3.1.2. Coordinating decisions between Alice and Bob

During this step, Alice and Bob usually have to pick their basis choices for the signal states and measurements randomly according to some distribution, to prevent Eve from knowing the basis choices used before the state is measured (most protocols become trivially insecure if Eve can do so). Similarly, for decoy-state protocols in particular, Alice would need to randomly choose some rounds in which to use the decoy-state intensities. The question then arises of which of these two possibilities is used:

- Alice and Bob jointly make these decisions, i.e. we allow their choices of signal states and measurements to be correlated.
- Alice and Bob independently make these decisions.

The first option often yields a protocol that is theoretically easier to analyze, but is difficult to achieve in practice, since Alice and Bob must coordinate this in such a way that Eve cannot learn values such as the basis choices before the state is measured.<sup>7</sup> The second option is practically easier as it requires no coordination between Alice and Bob (and is also more compatible with passive setups), but it results in them using different basis choices in some rounds. The protocol must thus clearly specify how to perform some subsequent processing steps (in particular, choosing test rounds in Section 3.2.2, and the sifting procedure in Section 3.2.5), and the security proof needs to analyze them appropriately.

#### 3.1.3. Distribution of rounds of each type

Another important aspect is the distributions Alice and Bob use for choosing their signal choices and measurements across the rounds. Broadly, most protocols follow one of two options:<sup>8</sup>

- Out of all the rounds, Alice and/or Bob pick random subsets of fixed size in which to use each signal choice and/or measurement.
- In each individual round, independently of all other rounds, Alice and/or Bob make a random decision of which signal choice and/or measurement to use.

Loosely speaking, these two options are respectively more compatible with the sampling-without-replacement and spot-checking approaches discussed in Remark 3.2 later; we defer a more detailed discussion to that point.

A protocol specification must clearly state which procedure is being used, and the security proof must analyze it using suitable theorems. We highlight in particular that for the second option, the number of rounds in which each signal choice or measurement is used is usually a random variable rather than a constant, which must be accounted for in the security proof; see Section 5.1.1.

<sup>7</sup> Some methods to achieve this for specific protocols were suggested in Ref. [9], by exploiting some amount of pre-shared key, but the techniques may not generalize to all protocols.

<sup>8</sup> One could also consider combinations of the two options (for instance, Alice uses the first option for basis choices but the second option for intensity choices); furthermore, either of them can be combined with either of the options discussed in the preceding section.



### 3.1.4. Total number of rounds

As noted above, in some protocols, the number of rounds where each signal choice or measurement is used can potentially be variable, especially for the case where these choices are made independently in each round. This raises the question of whether the total number of rounds can also be variable. For instance, one can consider protocols where Alice continues sending states until a certain number of rounds have been sent in a particular basis, or until a certain number of detections<sup>9</sup> have been obtained. However, security proofs for such protocols must then address this aspect appropriately, especially in terms of the statistical analysis — see Section 5.1.2 for further discussion.

## 3.2. Public announcements and processing

In this step, the parties perform some processing of their raw data, usually with the aid of some public announcements. Qualitatively, this processing serves the purpose of transforming the data into a form that can yield a higher secret key rate in the end. For this work, we require that at the end of this step, one of the parties has already finalized the string that they will use as the input to the privacy amplification step (Section 3.5), which we will refer to as the pre-amplification string. We now describe examples of various forms of such public announcements and processing.

### 3.2.1. Public announcements

In many protocols, Alice and Bob would announce their choices of signal states and measurement bases respectively. Bob would also announce whether he obtained a detection in each round. These announcements allow them to perform various processing operations described below, such as choosing test rounds (Section 3.2.2) and sifting (Section 3.2.5). Note that further public announcements may take place during other processing operations as well.

**Remark 3.1.** *In the protocol structure outlined here, we have described the public announcements as taking place after the entire prepare-and-measure step has been completed. In principle, one could instead consider the possibility of making some announcements while that step is still ongoing, which we shall refer to as **on-the-fly announcements**.<sup>10</sup> However, many proof techniques are not straightforwardly compatible with this scenario; we briefly highlight the techniques that can accommodate it in Section 5.1.2.*

### 3.2.2. Choosing test rounds and announcing test data

Alice and Bob need to decide on some subset of rounds to label as **test rounds**, for which the raw data will later be used the acceptance test or variable-length decision. The remaining rounds will be referred to as **generation rounds**.

There is considerable freedom in the procedure for choosing the test rounds, also depending on the distributions used in the prepare-and-measure step. As a simple example, the test rounds could be chosen based only on the raw data held by one party, for instance all the rounds in which Alice chose a particular basis (or a decoy-state intensity, for decoy-state protocols). Other options are to choose the test rounds to be those where *both* parties used a particular basis, or those where *at least one* used a particular basis, or to introduce some further randomness in choosing the test rounds — there are a wide variety of possibilities, and a protocol specification must be clear about which is being used.

Once the test rounds have been chosen, Alice and Bob would then usually<sup>11</sup> announce the raw data values for those rounds. These announcements provide the data required for the acceptance test (Section 3.3 below).

**Remark 3.2.** *The two options for signal and measurement choices previously discussed in Section 3.1.3 (namely, using a fixed number of each type of round, or making an independent choice in each round) can have a significant impact on the resulting distribution of test rounds. For instance, if Alice uses the first option (using a fixed number of rounds for each signal choice) and the test rounds are chosen based only on her signal choices, then the number of test rounds can be a fixed constant.<sup>12</sup> Such scenarios are sometimes referred to as **sampling without replacement** (this*

<sup>9</sup> Note that this option would require announcing detections while the prepare-and-measure step is still ongoing; see Remark 3.1 and Section 5.1.2 for possible issues.

<sup>10</sup> It would usually not be safe to announce (say) the basis choices for a particular round before the state in that round has been measured, since Eve could then use that information to adapt her attack; however, one could consider for instance announcing the basis choices immediately after the measurement in that round has been completed.

<sup>11</sup> In principle, the parties may not need to “directly” announce all the test-round data at this step — there can be protocols [9, 10] in which some of this data is instead “compressed” into the data that Alice sends later in the error correction step. However, this comes at the cost of additional complications in the implementation and analysis; we briefly discuss this later in Section 3.3.1.

<sup>12</sup> Note however that if Alice and Bob made independent choices of signal states and measurements, and the choice of test rounds depends on *both* their data, then the resulting number of test rounds might also not be a constant; see Section 5.1.1 for potential mistakes regarding this point.



can also be realized by any other method that results in a fixed number of test rounds). On the other hand, if the second option (making an independent choice in each round) is used, then it is often the case that each round is independently a test or generation round. Such scenarios are sometimes referred to as **spot-checking** or **infrequent-sampling**.

### 3.2.3. Random permutation

Some proof techniques (see for instance Section 6.3 later on the postselection technique) require that Alice and Bob explicitly perform a random permutation of their raw data, in order to enforce some symmetry properties required for the proof. More precisely, this consists of one party (say, Alice) choosing some permutation using local randomness, publicly announcing it, and then having both parties apply this permutation to their raw data. Note that there exist simple algorithms to implement such permutations with reasonable efficiency, in terms of both computational complexity and the number of random bits required [11].

### 3.2.4. Classical postprocessing

In many protocols, Alice and Bob remap their raw data into new values, producing a transformed string that is used in subsequent stages of the protocol. This postprocessing can be motivated by various factors, including convenience or technical requirements of the proof technique.

For example, a common approach is for Bob to randomly assign double-click events (both detectors in a given basis clicking) to one of the two detectors. In proofs that rely on the Entropic Uncertainty Relation (EUR) (see Section 6.1) and phase error correction (see Section 6.2) methods, such postprocessing is necessary to satisfy the basis-efficiency mismatch assumption in the canonical detector model. Another instance where postprocessing becomes essential is the use of squashing maps, as certain squashing maps only exist when specific postprocessing steps are applied.

It is worth noting, however, that in many scenarios, this postprocessing is not required for error correction. In such cases, Alice and Bob can fully utilize their raw data during the error correction phase, maximizing the use of available information.

### 3.2.5. Sifting

A common form of classical postprocessing is **sifting**, in which the parties “discard” data from some rounds. For instance, they would usually discard rounds in which Bob did not receive a detection, because we informally expect that such rounds do not contribute meaningfully to generating secret key between Alice and Bob. Another form of sifting is when Alice and Bob make independent basis choices and discard rounds in which they picked different basis choices. They may also wish to omit the raw data from the test rounds in the pre-amplification string (after choosing them according to some procedure as discussed in Section 3.2.2), as such data have already been publicly announced and Eve knows the values in those rounds.

We highlight a subtlety in the notion of “discarding” rounds in the sifting procedure: in many protocols, this is taken to mean that such rounds are entirely removed from the data, i.e. the resulting data string is genuinely shorter than before. However, this introduces some technical issues in applying existing proof techniques, which are more suited for analyzing procedures in which the raw data for such rounds is instead replaced with some fixed value, rather than being literally discarded. We defer a discussion of these issues, as well as how to overcome them, to Section 5.6.2.

### 3.2.6. Noisy preprocessing

Another possible operation is **noisy preprocessing**, in which a small amount of trusted noise is added to one party’s raw data (say, Alice’s) in each round. It has been shown that this can in fact improve the key rate in some situations [12–14] — informally, the idea is that the added noise “degrades” Eve’s knowledge about Alice’s secret data more than it “degrades” Bob’s.

### 3.2.7. Advantage distillation

For this work, we use the term **advantage distillation** to broadly refer to a wide variety of processing procedures involving two-way communication that can be used to improve the key rates in some situations [15–20]. One example

of advantage distillation is the repetition-code protocol [15, 19, 20], in which Alice and Bob divide their raw data into blocks and announce some data about each block, then discard blocks in which the announcements indicate the values in that block are more “poorly correlated”. This can potentially improve the key rates by preserving only the blocks with “stronger correlations”. However, in this work we will mostly not discuss advantage distillation procedures in much detail.

### 3.3. Acceptance test or variable-length decision

For a fixed-length protocol, in this step Alice and Bob make a “binary” decision of whether the protocol accepts or aborts, which we refer to as an **acceptance test**. Qualitatively, the idea is that they are attempting to detect whether Eve is eavesdropping on their communication “more strongly” than some threshold amount, and aborting if they detect such eavesdropping. If they accept, they will produce a key of fixed length in the final privacy amplification step (as long as the subsequent error verification step does not abort). For a variable-length protocol, in this step they instead make a decision of what length of key they will produce at the final privacy amplification step, which we refer to as a **variable-length decision**. Analogously, the idea here is that they are attempting to quantify the amount of eavesdropping by Eve, which will allow them to compensate for it via privacy amplification.

**Remark 3.3.** *Many procedures in this step are often based on computing the **frequency distribution** observed on some classical registers gathered during the protocol; in other words, the fraction of rounds in which each outcome was observed. We emphasize that when specifying a protocol and presenting its security proof, it must be clearly specified whether the denominator in this fraction is the total number of protocol rounds, or only the number of sifted rounds or test rounds. Different proof techniques may be compatible to different extents with these different possibilities, especially since values such as the number of sifted rounds may be random variables rather than constants.*

#### 3.3.1. Acceptance test (fixed-length protocols)

Typically, an acceptance test consists of one or both of the parties computing the frequency distribution observed on some classical registers, and then accepting (for this step) if and only if this frequency distribution lies in some predetermined set, which we shall call an **acceptance set**. We stress that for a fixed-length protocol, the acceptance set must be fixed *before* the protocol begins, and the protocol can only output a key of a fixed length whenever it accepts. Any other form of dependence of the key length on the observations in the protocol would make it a variable-length protocol instead.

For many protocols, the accept/abort decision is based entirely on the various registers publicly announced in the previous steps, such as the test-round data, in which case Alice and Bob can clearly come to a common decision in this step. Some protocols may instead have one of the parties make this decision based on some values that were not publicly announced, in which case that party would then need to announce their final accept/abort decision.<sup>13</sup>

As we shall discuss later in Section 4.5, some care needs to be taken in interpreting the output state of such a protocol. For instance, it is *not* valid to say that conditioned on the protocol accepting, the probability of Eve knowing the final key is small — we describe simple counterexamples in Section 4.5. However, it is indeed possible to prove that the final output state satisfies the composable security definitions described in Refs. [5, 6], which in turn means that it satisfies the various desirable properties implied by that definition.

#### 3.3.2. Variable-length decision (variable-length protocols)

In such protocols, in this step Alice and Bob come to a decision of the length of key they will output at the end. Depending on the protocol, at this point they might also decide on the error correction procedure they will use in the next step (Section 3.4); in particular, this means that the number of bits communicated in that step may potentially also be variable, and depend on the observations made during the protocol.

Such protocols can be more challenging to analyze when constructing security proofs, as the security definition is more elaborate (see Definition 2.1). For instance, it is often important to specify whether the variable-length decision

<sup>13</sup> While such protocols are not common, a possible example would be protocols in which the test-round data is not “directly announced” during the public announcement step, and instead some additional data is sent during the error correction step for Bob to produce a guess for Alice’s test-round data, which he then uses to make the acceptance test decision. Note that this requires error correction to be performed *before* the acceptance test, rather than the step order outlined in this work. To prove security for such protocols, the acceptance-test analysis must then account for the possibility that his guess might be wrong; see [9] for further details.

is based only on the public announcements before this step, rather than involving “private information” held only by one of the parties. Another technicality is that if the number of bits communicated for error correction is variable, then this raises questions regarding how to account for this when choosing the final key length — it may not be valid to assume one can simply choose the length of the final key depending on the number of bits actually communicated in error correction. Broadly speaking, current security proofs mostly cover only scenarios in which the final key length is determined completely by the public announcements before error correction.

### 3.4. Error correction and error verification

Recall that at this point, one of the parties already holds their **pre-amplification string** that will be held unchanged until the final privacy amplification step. However, the other party still usually does not know the exact value of that pre-amplification string, since their initial raw data would have been subject to some level of noise with respect to each other. In light of this fact, error correction is performed, in which further public communication is used to allow the latter party to generate their own pre-amplification string, which is intended to match the other’s with high probability. This may then be followed by error verification, which refers to a process in which Alice and Bob attempt to verify whether their pre-amplification strings indeed match.

#### 3.4.1. Error correction

Broadly, error correction procedures can be classified into those that only use one-way communication, and those that use two-way communication. In this work, we will mostly focus on the former, which is often referred to as **one-way error correction**, though we briefly discuss the latter at a few points. We now elaborate further on these options.

**Direct reconciliation.** This is the form of one-way error correction used in most currently implemented protocols for decoy-state BB84. Here, Alice (i.e. the party who prepared the signal states, not the one who measured them) is the party who holds the pre-amplification string after the preceding step, and the error correction procedure consists of her computing a classical string from her pre-amplification string and sending it to Bob, who then uses it together with all the data on his side to produce a guess for Alice’s pre-amplification string. Qualitatively, this is usually achieved by having Alice compute the syndrome of a suitable error-correcting code as the string to send to Bob, though there are some slight variations. For instance, some proof techniques may require Alice to furthermore apply a one-time-pad to this syndrome before sending it to Bob (see Section 6.2 for further discussion of when this is necessary), which requires a significant amount of preshared secret key to perform, though the resulting *net* gain in shared secret key is usually the same as other proof techniques.

**Reverse reconciliation.** This is also a form of one-way error correction, but it instead requires that Bob is the party who holds the pre-amplification string after the preceding step, and hence he sends a classical value to Alice for her to produce a guess for Bob’s pre-amplification string. For some protocols, this can potentially yield better key rates than direct reconciliation. We highlight however that the security proof does need to be structured such that it correctly accounts for the fact that Bob is the party who first holds a pre-amplification string; we return to this point in Section 5.4.2.

**Two-way error correction.** Some error correction procedures involve communication in both directions between Alice and Bob. An example of this is the Cascade protocol [21], in which the parties potentially perform several rounds of communication. However, the number of communicated bits in such protocols is usually significantly higher than in one-way error correction, and this issue need to be treated with care in the security proof.

**Remark 3.4.** *When specifying an error correction procedure for a QKD protocol, one critical point that must be addressed is whether the number of communicated bits is a fixed value or a random variable. For fixed-length protocols, many security proofs can only handle the former case, or cases where there is a fixed upper bound on the number of communicated bits. For variable-length protocols, some proof techniques can handle the latter, though there are technical conditions that must be satisfied. We return to these points in Section 5.4 later.*

#### 3.4.2. Error verification

After error correction, the error verification procedure usually consists of one party announcing a 2-universal hash (see Section 4.2) of their pre-amplification string, with the other party checking to see whether they obtained a

pre-amplification string with the same hash, and aborting if that is not the case. Qualitatively, this serves as a check on whether their pre-amplification strings match, since the properties of 2-universal hashing ensure that if the pre-amplification strings differ, the probability of their hashes matching is small. We stress however that this is a very different statement from claiming that if their hashes match, the probability of them having distinct pre-amplification strings is small. In the security proof, it would *not* be valid to make the latter claim; fortunately, the former claim is enough to prove that the correctness condition is satisfied, as we discuss in Section 4.3.

One important benefit of error verification is that it allows the error correction procedure (and related procedures in the preceding step) to be designed based on the *honest* behaviour of the protocol. Intuitively, this is because while such an error correction procedure might fail to give Alice and Bob matching values in the presence of dishonest behaviour, the error verification procedure serves to ensure the correctness condition holds regardless of what happened during error correction. This feature is particularly useful from the viewpoint of security proofs for fixed-length protocols, because for instance it usually allows the number of communicated bits in one-way error correction to be chosen as a specific fixed value, corresponding to the honest behaviour. This often simplifies the security proofs.

**Alternatives to error verification.** In principle, some protocols may not perform an error verification step in the above form. For instance, one possible alternative used in some earlier protocols [19] was to perform an acceptance test that implicitly checks whether the number of errors between their raw data strings is below some threshold, aborting if it is not. Given suitable error correction procedures in such a scenario, it is still possible to prove that the correctness condition holds; however, this requires more stringent conditions on the error correction procedure (roughly speaking, they have to be analyzed in the context of dishonest behaviour as well).

**Error verification after privacy amplification.** Another slight variant of error verification is that if the subsequent privacy amplification step (Section 3.5) is also performed using 2-universal hashing, the parties can instead implement error verification *after* privacy amplification. To do so, one party simply announces a fixed subset of their final key bits and the other party checks if those bits match. It is straightforward to slightly modify the security proof to show that the final key with those bits excluded indeed satisfies the required correctness and secrecy properties. However, this variant may not be straightforwardly applicable if privacy amplification is performed with other extractor procedures instead.

### 3.5. Privacy amplification

At this point, Eve may still have some limited knowledge about Alice and Bob’s pre-amplification strings<sup>14</sup> — as a very simplistic example, Eve might know a small subset of the bits in those strings. The purpose of privacy amplification is to transform the pre-amplification strings into final keys that are perfectly uniform and entirely decoupled from Eve, up to the amount of “ $\epsilon^{\text{secret}}$ -imperfection” allowed in the secrecy definition (Definition 2.2). To do so, these final keys are usually shorter than the pre-amplification strings; informally, we can say that Alice and Bob “sacrifice” some key bits in order to remove the correlation with Eve. We now discuss some procedures that achieve this.

**2-universal hashing.** A possible method for privacy amplification is for one party to choose a random hash function from a 2-universal family (see Section 4.2) using some local randomness, which is sometimes termed as the **seed** for the privacy amplification procedure. They then publicly announce their choice, after which both parties apply that choice of hash function to their pre-amplification strings. The core theoretical tool that ensures security from this procedure is the **Leftover Hashing Lemma** (Section 4.4), which qualitatively states that if the input to the hash function has “enough entropy” relative to the length of the output, then the output will be nearly uniform and decoupled from any other side-information.

**Other extractors.** Apart from 2-universal hashing, there are other procedures that can be used for privacy amplification, broadly referred to as **randomness extractors**. Qualitatively, these procedures achieve similar results to the Leftover Hashing Lemma, in that they produce outputs that are nearly uniform and decoupled from any side-information, as long as the inputs have “enough entropy” — the difference is that the operation performed on the pre-amplification string does not have to be a 2-universal hash. One noteworthy example of an extractor that does not simply apply a 2-universal hash is **Trevisan’s extractor**. This has the advantage that it requires less seed randomness as compared to 2-universal hashing; however, it can be more elaborate to implement, and some forms of

---

<sup>14</sup> This is because the acceptance test usually has to be designed to accommodate some amount of noise even from the honest behaviour, and hence it cannot rule out the possibility that Eve may be “hiding” her eavesdropping in that amount of noise.

privacy amplification theorems have only been proven for 2-universal hashing rather than Trevisan’s extractor.

**Privacy amplification with variable input lengths.** A technical point arises in privacy amplification regarding the domain of the input to the procedure. In particular, for some protocols the lengths of the pre-amplification strings are not fixed constants, for instance because some bits are literally discarded during the sifting procedure or other processing steps. Other protocols may instead have pre-amplification strings that are not bitstrings, for instance if bits that are sifted out are replaced with some special “blank” symbol. In such circumstances, one cannot “directly” implement procedures such as Toeplitz hashing, which were only designed to take bitstrings of fixed-length as input. A full protocol specification in such cases must explicitly state the exact procedure used for privacy amplification (for instance, a different family of Toeplitz matrices is used depending on the length of the pre-amplification strings), and the security proof must rigorously analyze this procedure accordingly. We return to this point in Section 5.6.2.

#### 4. Concepts in security proofs

Having explored the diverse range of protocol choices in QKD, we now turn our attention to the foundational concepts required for the theoretical analysis of QKD protocols. In this section, we will briefly explain some key concepts needed for rigorous security proofs.

##### 4.1. Source-replacement scheme

Broadly, the source-replacement scheme [22, 23] is used, as the name suggests, to replace the actual source with a virtual entangled source, which when coupled with a measurement on Alice’s subsystem can mimic the actual source. The exact entangled source and measurement used depends on the proof-technique — some proof techniques (phase error and EUR) use this to reduce Alice’s subsystem to a qubit system to simplify the analysis, while others (postselection and EAT-based) instead require an IID source preparation that need not be a qubit.

An important consideration when using the source-replacement scheme is that information about the pairwise inner products of signal states should, in general, be included in the security analysis<sup>15</sup>. Once again, different security proofs handle this differently. The postselection and EAT-based proof techniques encode the overlap structure by adding an additional constraint on the marginal of the entangled state shared by Alice and Bob. The phase error correction and EUR proof techniques instead include this information when connecting the test-round statistics to the phase errors in generation rounds.

###### 4.1.1. Shield system

A special case of the source-replacement scheme where Alice prepares a mixed state can be used by introducing a *shield system* [24]. This works as follows. Alice’s mixed state preparation can be thought of as first preparing a pure state (purification of the mixed state), and then tracing out part of it to prepare the mixed state. However, this tracing out can be performed after the measurement phase since it commutes with the measurements. Thus, we can simply assume that Alice prepares pure states, part of which are sent to Bob. Note that the shield system is considered to be inaccessible to Eve, although Alice does not perform any operations on it during the protocol. This fact must be taken into account in the security proof, for instance through an additional constraint on Alice’s subsystems, including her shield system.

##### 4.2. 2-universal hashing

Informally, hash functions usually serve the purpose of “compressing” long input strings into shorter output strings, in such a way that the event of different input values giving the same output value (usually called a **collision**) is “rare” in some sense. 2-universal hashing serves as a rigorous way to formalize this intuition, as seen from its definition.<sup>16</sup>

<sup>15</sup> Intuitively, this is to be expected since we know that QKD cannot be performed with orthogonal states. Thus, somehow we must include the information that the source prepares non-orthogonal (and hence, not perfectly distinguishable) states in our security analysis.

<sup>16</sup> There exists a generalization of 2-universal hashing referred to as  $\delta$ -almost-2-universal hashing [25], but we will not cover it in detail within this work.

**Definition 4.1.** Given some domain  $D$  and finite codomain  $D'$ , a **2-universal hash family** is a set  $\mathcal{H}$  consisting of functions  $h : D \rightarrow D'$ , together with a probability distribution over  $\mathcal{H}$ , such that if we randomly draw a function  $h$  from  $\mathcal{H}$  according to that distribution, we have:

$$\text{For all } x, y \in D \text{ such that } x \neq y, \quad \Pr[h(x) = h(y)] \leq \frac{1}{|D'|}, \quad (8)$$

where the probability is evaluated with respect to the distribution over  $\mathcal{H}$ .

**Remark 4.1.** We strongly emphasize that 2-universal hashing is a very distinct concept from using fixed choices of computationally-hard functions (or functions with “heuristic hardness estimates”, such as SHA-3), and should never be confused with those notions. In particular, we stress that no computational-hardness assumptions or heuristics are needed to construct 2-universal hash families that satisfy the above definition.<sup>17</sup> Hence 2-universal hashing allows us to rigorously ensure information-theoretic security, without computational assumptions.

Slightly informally, we often refer to the overall process of randomly drawing a function  $h$  from a 2-universal hash family and applying  $h$  to some classical register as “applying a 2-universal hash”, and we will refer to the output value as the hash. For most 2-universal hash families used in QKD, the relevant distribution over  $\mathcal{H}$  is simply a uniform distribution, though this is not a required property in the definition. Furthermore, the codomain  $D'$  usually just consists of bitstrings of some length  $\ell_{\text{hash}}$ , so the above bound reduces to

$$\text{For all } x, y \in D \text{ such that } x \neq y, \quad \Pr[h(x) = h(y)] \leq \frac{1}{2^{\ell_{\text{hash}}}}, \quad (9)$$

i.e. it is exponentially small with respect to the length  $\ell_{\text{hash}}$  of the output strings. We now highlight some other important properties of 2-universal hashing.

**Existence and efficiency.** There exist explicit constructions of 2-universal hash families that are reasonably efficient, with respect to both computational complexity and the randomness required to draw from that family. (We again stress that no computational-hardness assumptions are needed to rigorously prove that these constructions satisfy the defining property, Eq. (8).) For instance, when the domain and codomain are both bitstrings of fixed-lengths, a commonly used choice for a 2-universal hash family is the set of **Toeplitz matrices**, as described in Ref. [26] (see also Ref. [27] for a discussion specific to Toeplitz hashing). This approach offers the advantage that there exist algorithms for efficiently computing the output of a Toeplitz matrix applied to a bitstring, and the number of random bits required to choose such a matrix is linear with respect to the lengths of the input and output strings.

**Interpreting the probability.** We emphasize that the probability term in Eq. (8) is defined *only* with respect to the distribution over  $\mathcal{H}$ , i.e. the random choice of hash function. In particular, there is no requirement of any probability distribution over the values  $x$  and  $y$ ; the bound holds for any distinct values  $x \neq y$ . Still, when we wish to apply this result in contexts where  $x$  and  $y$  are random variables, we can say this implies that conditioned on  $x \neq y$ , the probability that  $h(x) = h(y)$  is small — note that this statement holds without any assumptions about the distributions of  $x$  and  $y$ .

**Applications in QKD.** As noted in Section 3, 2-universal hashing is used in many aspects of QKD, for instance in the following steps.

- Most straightforwardly, it is used in the error verification step, where a 2-universal hash is used to attempt to check whether Alice and Bob obtained matching pre-amplification strings. The fact that it ensures a rigorous bound on the “collision probability” is highly relevant in analyzing this step, as we describe in Section 4.3.
- It is also applied in many commonly used procedures for privacy amplification. Here, the bound on the collision probability is less “directly” relevant; the key property that ensures security is the Leftover Hashing Lemma (Section 4.4).
- A slightly strengthened version of 2-universal hashing can also serve as a possible method for the construction of the authenticated classical channel, via Wegman-Carter authentication [7, 8], though we do not consider this within the scope of the QKD security proof itself.

---

<sup>17</sup> To achieve this, it was critical that the function  $h$  is drawn randomly from some family in 2-universal hashing — notice that if  $h$  had been a fixed function and  $|D| > |D'|$ , then it would have been impossible to find a bound of the form in Eq. (8) without further assumptions, since we would necessarily have a collision by the pigeonhole principle.



### 4.3. The correctness condition

By definition, the correctness condition requires us to show that the probability that the final keys differ *and* the protocol accepts (or that it produces a nonzero key length, in the variable-length case) is small. We first note that for protocols with error verification, this event is a “stricter” event than the event of the **pre-amplification strings** differing and the error verification step accepting.<sup>18</sup> Thus it suffices to upper-bound the probability of the latter event. This turns out to be fairly straightforward for error verification based on 2-universal hashing: observe that if the error verification hash is a bitstring of length  $\ell_{\text{hash}}$ , then

$$\begin{aligned} & \Pr[\text{pre-amplification strings differ AND error verification accepts}] \\ &= \Pr[\text{error verification accepts} \mid \text{pre-amplification strings differ}] \Pr[\text{pre-amplification strings differ}] \\ &\leq \Pr[\text{error verification accepts} \mid \text{pre-amplification strings differ}] \\ &\leq 2^{\ell_{\text{hash}}}, \end{aligned} \tag{10}$$

where the second line is Bayes’ rule, the third line holds simply because probabilities are upper bounded by 1, and the fourth line follows from the defining property of 2-universal hashing (Definition 4.1). Hence by choosing  $\ell_{\text{hash}}$  appropriately, the correctness condition is satisfied.

An important aspect of this argument is that it relies solely on the properties of error verification based on 2-universal hashing; in particular, it has no dependence at all on any properties of the preceding error correction step. This implies that for protocols using such an error verification procedure, the error correction procedure can be designed such that it is only guaranteed to succeed with high probability on the honest behaviour (so the completeness condition is fulfilled), rather than having to consider any form of dishonest behaviour at that step, since the correctness condition is ensured by the error verification step alone. Hence this form of error verification usually simplifies the security analysis. Note however that this is not the case for some of the variants discussed in Section 3.4.2; a more elaborate analysis may be required for some of those cases.

We highlight that the correctness condition does *not* require one to show that conditioned on the protocol accepting, the probability that the final keys differ is small — it only requires us to bound the probability of the joint event, rather than this conditional probability. In fact, one can construct explicit examples of attacks by Eve in which conditioned on the protocol accepting, the probability that the final keys differ is still large, i.e.

$$\Pr[\text{pre-amplification strings differ} \mid \text{error verification accepts}] \approx 1. \tag{11}$$

Therefore, it would be a misconception to claim that this conditional probability is small for QKD protocols satisfying the security definitions. However, as discussed in Refs. [5, 6], the composable security framework ensures that the correctness condition in the stated form is already enough to certify the desired composable properties of the protocol, despite the lack of a bound on this conditional probability.

### 4.4. Leftover Hashing Lemma

A critical result for proving secrecy in a QKD security proof is the **Leftover Hashing Lemma** [4, 19, 28] — while there are many variants, we focus on the one in [4, Proposition 9] for the purposes of this discussion, as it is most compatible with the definitions we introduced in Section 2. We can summarize the lemma as follows: for any state  $\rho_{CQ}$  with classical  $C$ , if we apply a 2-universal hash to  $C$  such that the output is a bitstring  $K$  of length  $\ell$ , and denote the resulting state as  $\rho_{KQH}$  where  $H$  is a register storing the choice of hash function, then<sup>19</sup>

$$d(\rho_{KQH}, \omega_K^\ell \otimes \rho_{QH}) \leq 2^{-\frac{1}{2}(H_{\min}^{\bar{\epsilon}}(C|Q)_\rho - \ell + 2)} + 2\bar{\epsilon}, \tag{12}$$

where  $\omega_K^\ell := \sum_{k \in \{0,1\}^\ell} \frac{1}{2^\ell} |k\rangle\langle k|_K$  denotes a uniformly random key of length  $\ell$  on register  $K$ . In other words, as long as  $\ell$  is somewhat shorter than the smooth min-entropy  $H_{\min}^{\bar{\epsilon}}(C|Q)_\rho$ , then the resulting state on  $KQH$  is close in trace distance to one where  $K$  is uniform and independent of  $QH$ . Critically, the register  $H$  is included in the “side-information” in this statement, so in the context of QKD protocols it means the choice of hash function can be

<sup>18</sup> This is because the final keys can only differ if the pre-amplification strings differ, and the protocol can only accept (or produce a nonzero final key length) if the error verification step accepts.

<sup>19</sup> In Ref. [4] (Proposition 9), a slightly generalized version of this lemma was presented for subnormalized states.

publicly announced.<sup>20</sup> We also highlight that more recently, a variant of the Leftover Hashing Lemma was developed based instead on the Rényi entropy, which often yields better finite-size performance, though the qualitative implications are similar.

By inspecting the secrecy definition (Definition 2.2), we see that being close to a state where  $K$  is uniform and independent of the “side-information” is similar in spirit to what is required in that definition. However, we wish to stress that it is *not* rigorous to directly claim that in a QKD security proof, one simply finds a fixed lower bound on the smooth min-entropy for all possible states and then hashes the pre-amplification string to a length slightly shorter than that value. This is due to the fact that there are critical obstacles to finding such a fixed bound, and furthermore there are various discrepancies between Eq. (12) and the secrecy definition — for instance, in the secrecy definition for fixed-length protocols there is a prefactor of  $\Pr[\Omega_{\text{acc}}]$ , and furthermore the trace-distance term is evaluated on the states conditioned on accepting. In the next section, we elaborate further on these issues, as well as the actual method to obtain a rigorous security proof.

**Remark 4.2.** *As noted in Section 3.5, there exist privacy amplification procedures not based on 2-universal hashing, such as Trevisan’s extractor [29]. However, the qualitative properties of those procedures are mostly similar to those of the Leftover Hashing Lemma. Furthermore, as mentioned there, additional care is necessary when analyzing privacy amplification if the pre-amplification strings are not bitstrings of fixed-length, since this may not technically fit the conditions of the Leftover Hashing Lemma. We briefly discuss this in Section 5.6.2 later, and a full rigorous treatment of this issue can be found in Ref. [30].*

#### 4.5. Estimating the entropy

Let us denote the pre-amplification string as  $\mathbf{S}$ , and Eve’s side-information just before privacy amplification as  $E_{\text{prePA}}$ . For brevity, in the following discussion we focus mainly on the Leftover Hashing Lemma based on smooth min-entropy; essentially similar statements hold for the Rényi version from Ref. [28].

We first discuss fixed length protocols, i.e. those which simply accept or abort and produce a key of fixed length whenever they accept. Given the Leftover Hashing Lemma, it might seem that to obtain a secret key, we would simply need to find some constant  $\kappa_{\text{const}}$  such that any state accepted in the protocol will be such that Alice’s pre-amplification string  $\mathbf{S}$  has smooth min-entropy (conditioned on Eve’s side-information  $E_{\text{prePA}}$ ) of at least  $\kappa_{\text{const}}$ , and then hash the pre-amplification string to a length somewhat shorter than  $\kappa_{\text{const}}$ . There are, however, two critical obstacles that prevent this from being a rigorous claim, which we now describe — for ease of reference, we recall here that the secrecy definition for fixed-length protocols (Eq. (5)) requires us to prove an upper bound on

$$\Pr[\Omega_{\text{acc}}] d\left(\rho_{K_A E_{\text{fin}}|\Omega_{\text{acc}}}, \omega_{K_A}^{\ell_{\text{fixed}}} \otimes \rho_{E_{\text{fin}}|\Omega_{\text{acc}}}\right). \quad (13)$$

We highlight in particular that it involves the states conditioned on accepting, and has a prefactor of the accept probability  $\Pr[\Omega_{\text{acc}}]$ .

**Conditioning changes entropies.** This is a slightly technical point, though it brings up issues that will be relevant in our later discussion of variable-length protocols. Namely, it is the question of *which state* we are bounding the smooth min-entropy of. As noted above, the secrecy definition (Eq. (5)) is formulated in terms of the final state conditioned on the protocol accepting, i.e.  $\rho_{K_A E_{\text{fin}}|\Omega_{\text{acc}}}$ . This implies that to apply the Leftover Hashing Lemma to bound the trace distance in that definition, we must bound the smooth min-entropy of the pre-amplification string *conditioned on accepting*, i.e. for the state  $\rho_{\mathbf{S} E_{\text{prePA}}|\Omega_{\text{acc}}}$ .<sup>21</sup> This is not the same as the state  $\rho_{\mathbf{S} E_{\text{prePA}}}$  without conditioning on accepting, and thus it would not be valid to apply the Leftover Hashing Lemma based solely on the smooth min-entropy of  $\rho_{\mathbf{S} E_{\text{prePA}}}$ . Still, this is mainly a technical issue that can be handled by using appropriate bounds relating the entropies of  $\rho_{\mathbf{S} E_{\text{prePA}}|\Omega_{\text{acc}}}$  and  $\rho_{\mathbf{S} E_{\text{prePA}}}$ , which we briefly describe in Remark 6.2 later. See also Section 5.6.3 regarding some other issues about conditioning on events.

**Impossibility of entropy bounds over all states.** This obstacle is more fundamental, namely: if we consider the smooth min-entropy of *all* states that could occur in the protocol, it is in fact impossible to find a constant lower bound  $\kappa_{\text{const}}$  other than the trivial value  $\kappa_{\text{const}} = 0$ , even conditioned on accepting.<sup>22</sup> This arises from the observation

<sup>20</sup> Including  $H$  in the “side-information” registers also means that the left-hand-side of Eq. (12) is equal to the average of the trace-distance values conditioned on each choice of the hash function; some works have stated the Leftover Hashing Lemma in terms of that expression instead.

<sup>21</sup> More precisely, as we discuss later in Remark 6.2, one may need to instead analyze the smooth min-entropy of the *subnormalized* state conditioned on accepting, and apply a suitable variant of the Leftover Hashing Lemma.

<sup>22</sup> This issue can technically be avoided by considering *subnormalized* conditional states, but it requires introducing a rigorous formalism of smooth min-entropies for such states; we briefly discuss this in Remark 6.2 later.

that Eve can always choose to perform an attack of the following form: first, she simply intercepts and collects all the qubits Alice sends, without measuring them, while forwarding arbitrary states to Bob. For simplicity let us now focus on<sup>23</sup> a fully qubit BB84 protocol in which Alice eventually announces all her basis choices, in which case after this announcement, Eve measures her collected states in those bases. The core property of this attack is that it allows Eve to *always* perfectly learn Alice’s entire raw data string, regardless of anything Alice and Bob do.

We stress the strength of this property: whenever Eve performs this attack, she knows Alice’s raw data with probability 1, so she knows it *regardless of any event we might condition on* — including the event that the protocol accepts. (While the probability of the protocol accepting under this attack is extremely small, this does not in any way imply that the probability that Eve knows Alice’s raw data is small, even conditioned on accepting. Also, the fact that the accept probability is small has no bearing on whether Eve is “allowed” to perform this attack — she can *always* choose to perform this attack, as long as she is willing to accept the small accept probability.) In particular, this means that the smooth min-entropy  $H_{\min}^{\varepsilon}(\mathbf{S}|E_{\text{prePA}})$  is nearly<sup>24</sup> zero, regardless of whether we are considering  $\rho_{\mathbf{S}E_{\text{prePA}}|\Omega_{\text{acc}}}$  or  $\rho_{\mathbf{S}E_{\text{prePA}}}$ . Hence the existence of this attack makes it fundamentally impossible to find a nontrivial constant  $\kappa_{\text{const}}$  such that any state accepted in the protocol has smooth min-entropy at least  $\kappa_{\text{const}}$ .

To overcome these obstacles, the security proof has to be constructed in a more precise fashion. The key observation is that as noted above, in the secrecy definition for fixed-length protocols (Eq. (5)), the trace-distance term is multiplied by a prefactor of the accept probability — while this makes it weaker than an analogous claim without this prefactor, it is still sufficient to yield composable security, in the sense discussed in Refs. [5, 6]. (In fact, our discussion above implies that the claim without this prefactor is simply not true, in that the attack where Eve collects all of Alice’s states yields a final state where the trace-distance term is large, as claimed in Eq. (3).) We now sketch out various methods to rigorously prove that this definition can indeed be satisfied.

#### 4.5.1. Filtered and unfiltered states

For fixed-length protocols, one security proof approach is to partition the set of all states (that could be produced by Eve’s attacks) into two subsets, which we refer to as **filtered** and **unfiltered** states. (This terminology is based on that used in [19] for single-round states in IID scenarios; here we adapt it slightly to refer to the global state in a potentially non-IID scenario.) Specifically, we define them as follows:

**Definition 4.2.** Given some fixed-length QKD protocol and some value  $\varepsilon_{\text{AT}} \in (0, 1)$ , we say a state is **filtered** by the protocol if its accept probability is at most  $\varepsilon_{\text{AT}}$ . Any state that is not filtered is referred to as **unfiltered**.

With this partitioning, we can now construct a security proof as follows. Suppose we find an explicit constant  $\kappa_{\text{const}}$  such that every unfiltered state yields a pre-amplification string with smooth min-entropy (conditioned on Eve’s side-information) of at least  $\kappa_{\text{const}}$ .<sup>25</sup> Given this, we would be able to perform the following case analysis for any state generated in the protocol:

1. *Either* it is a filtered state, in which case the  $\Pr[\Omega_{\text{acc}}]$  prefactor is upper bounded by  $\varepsilon_{\text{AT}}$ , and the trace-distance term is trivially upper bounded by 1,
2. *Or* it is an unfiltered state, in which case the smooth min-entropy is at least  $\kappa_{\text{const}}$ , hence we can apply the Leftover Hashing Lemma to bound the trace-distance term (after applying suitable techniques to account for conditioning on  $\Omega_{\text{acc}}$ , as mentioned above).

From this we can conclude that the secrecy definition is always satisfied, regardless of which case holds (taking  $\varepsilon^{\text{secret}}$  to be the larger value between  $\varepsilon_{\text{AT}}$  and the bound obtained from the Leftover Hashing Lemma in the second case). This proof approach avoids the obstacle raised above regarding obtaining a nontrivial constant lower bound  $\kappa_{\text{const}}$ , because it only needs to hold for the set of unfiltered states, not the set of all states — specifically, that particular attack would usually fall into the set of filtered states, depending on the exact choice of  $\varepsilon_{\text{AT}}$ .

**Remark 4.3.** *We strongly emphasize that at no point in the above argument did we speak of the probability that Eve is performing a particular attack, or the probability that she is generating a filtered or unfiltered state. These probabilities*

<sup>23</sup> Here we only focus on this example for ease of explanation; the general principle basically holds for other protocols as well.

<sup>24</sup> It is not exactly zero because of the smoothing, but for a state of this form, the smooth min-entropy is still very close to zero.

<sup>25</sup> Here we maintain flexibility in whether we are referring to the state  $\rho_{\mathbf{S}E_{\text{prePA}}|\Omega_{\text{acc}}}$  or  $\rho_{\mathbf{S}E_{\text{prePA}}}$ , i.e. with or without conditioning on accepting. Different proof techniques may rely on either version — as mentioned above, it is usually still possible to use the latter case by invoking suitable bounds that relate it to the smooth min-entropy after conditioning on  $\Omega_{\text{acc}}$ , which we briefly describe in Remark 6.2 later.

are not well-defined concepts in the security definitions, which are couched in terms of statements that must hold against all possible attacks by Eve, rather than some probability distribution over those attacks. Our argument is merely a case analysis statement that one of the above cases must hold, and the secrecy definition is satisfied in either case.

With this, we see that the goal of the security proof basically reduces to finding a lower bound  $\kappa_{\text{const}}$  on the smooth min-entropy of any unfiltered state. This is the purpose served by the test rounds and the acceptance test: they define the set of unfiltered states (for a given  $\varepsilon_{\text{AT}}$  value), and our goal is to find a nontrivial lower bound on their smooth min-entropy. Note that it is usually impractical to compute the *exact* value of the minimum smooth min-entropy over all unfiltered states; instead, one usually relaxes the set of unfiltered states to some larger set, and lower bounds the smooth min-entropy over that set instead. This is still a valid proof approach, because the resulting value is still a valid lower bound  $\kappa_{\text{const}}$ .

There are various “degrees of freedom” in this proof approach — for instance, the choice of  $\varepsilon_{\text{AT}}$  and the protocol’s accept condition defines the set of unfiltered states, and furthermore there are various possible choices when relaxing this set to a larger set. Hence when writing a security proof, one has to make these choices in such a way that a valid and reasonably tight lower bound  $\kappa_{\text{const}}$  can be practically computed.

#### 4.5.2. Entropy bounds with accept-probability dependence

As an alternative to the above case analysis, another proof approach is as follows. Rather than attempting to find a *constant* lower bound  $\kappa_{\text{const}}$  on the smooth min-entropy or Rényi entropy (conditioned on  $\Omega_{\text{acc}}$ ) that holds only for states in some restricted set (i.e. the unfiltered states), somewhat informally speaking we can find a bound that instead has some dependence on the accept probability  $\Pr[\Omega_{\text{acc}}]$ , but holds for all states.<sup>26</sup> This dependency on  $\Pr[\Omega_{\text{acc}}]$  can potentially avoid the obstacle imposed by the attack described above, which has a very small value of  $\Pr[\Omega_{\text{acc}}]$ , i.e. such a bound is possible in principle as long as it becomes trivial whenever  $\Pr[\Omega_{\text{acc}}]$  goes to zero.

While the probability  $\Pr[\Omega_{\text{acc}}]$  cannot be operationally observed, it is still well-defined, and in some situations it is possible to construct a security proof such that this dependency is correctly “compensated for” by the  $\Pr[\Omega_{\text{acc}}]$  dependence in the secrecy definition. Such security proofs have been obtained in e.g. [28, 31], and in the rest of this work we will occasionally comment on which proof techniques allow this approach.

#### 4.5.3. Variable-length protocols

For variable-length protocols, the analysis is more elaborate, so here we only give a very informal summary. Note that the secrecy definition for variable-length protocols qualitatively states that the final state is close to a *mixture* of states where the key is uniform and independent of the side-information. With this in mind, the idea of the security proof is essentially to use the test-round data to construct a “statistical estimator” of the smooth min-entropy or Rényi entropy of the pre-amplification string, then hash to a length determined by that statistical estimator. If it can be shown that this statistical estimator bounds the true entropy value with high probability, then under some additional conditions, it can be shown that the variable-length secrecy definition holds. However, formalizing this intuition requires some careful analysis; furthermore, recall that one must account for the fact that conditioning on each value for the output key length can change the entropy value. Hence we defer further discussion to Section 5.5.

### 4.6. Reduction theorems: optical modes to finite dimensions

QKD protocols are typically implemented via quantum optical systems, which are described by (tensor products of) infinite-dimensional Hilbert spaces. Thus, when discussing optical implementations of QKD protocols, some subtle problems arise due to the dimensionality of the spaces. For instance, for numerically computing key rates, infinite-dimensional optimisations cannot be given to a computer. There has been much work to develop tools to reduce the security proofs of these infinite-dimensional protocols to the analysis of “equivalent” finite-dimensional protocols. Although the ideas are fairly similar, we broadly classify these tools into two subgroups:

1. Source maps [32] that help reduce the analysis of infinite-dimensional sources to equivalent finite-dimensional sources.

---

<sup>26</sup> In proofs that involve subnormalized conditional states (see Remark 6.2 later), we view this dependence as being implicitly mediated by the entropy definitions for subnormalized states.

- 2. Squashing maps [11, 33–39] that help reduce the analysis of infinite-dimensional detection setups to equivalent finite-dimensional detection setups.

4.6.1. Source maps

The main idea behind source maps is fairly intuitive, as described in Fig. 1. The real source is modelled as a virtual source followed by a ‘source map’, and the source map is then ‘given’ to Eve. In particular, it is then assumed that Eve is allowed to replace the source-map with any map of her choice. Thus, the security analysis can be restricted to the more convenient virtual source. Formally, given the set of (infinite-dimensional) states  $\{\rho_i\}$  used in the protocol,

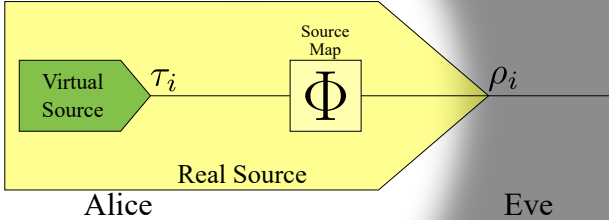

(a) We can model the real source as a virtual source followed by a source map since they both have the exact same output.

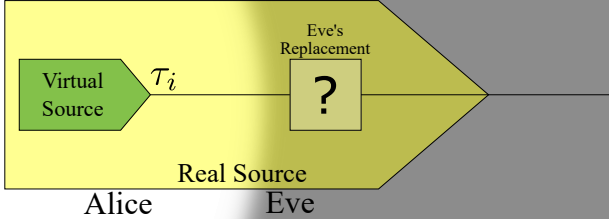

(b) Once we give Eve control of the source map, she can perform any physical operation on the output of the virtual source, including the source map  $\Phi$  if reproducing the real state is optimal for her.

FIG. 1: The real source can always be replaced by the virtual source in security proofs if they are related via a source map since the virtual source gives Eve more power.

we find a set of (finite-dimensional) states  $\{\tau_i\}$  such that there exists a channel  $\Phi$  where  $\rho_i = \Phi(\tau_i)$  for all  $i$ . This channel  $\Phi$  constitutes the *source map* which is ‘given’ to Eve, and thus any security analysis that assumes that Alice prepares the states  $\{\tau_i\}$  would also hold for the actual protocol where Alice prepares the states  $\{\rho_i\}$  as this only gives Eve more power. See [11, Lemma 8] for a more formal proof of this.

An important source map that is often used for decoy-state protocols is tagging [40]. When the real source emits block-diagonal states, we can replace it with a virtual source that probabilistically emits either a finite cut-off of the real states, or a ‘tag’ with information, readable by Eve, that reveals the exact state prepared. For instance, a polarization encoded decoy-state protocol utilizes a source that prepares fully phase-randomized coherent states which are block-diagonal in the total number of photons in all polarizations. This source can then be replaced with a virtual source that probabilistically emits a vacuum state, a single-photon state, or a “tag”.

4.6.2. Squashing maps

A large variety of squashing maps exist to reduce detection setups to finite dimensions. We summarize the majorly used squashing maps (also called “squashers”) in Table I. We briefly describe the main idea behind each of them.

**Proof-technique independent squashers:** The simple squashers and weight-preserving flag-state squasher use the same general principle [33–35, 37] depicted in Fig. 2, similar to source maps. These squashers allow us to directly replace the infinite-dimensional POVM with a finite-dimensional POVM for a QKD security proof. That is, they work by proving that the security of the QKD protocol with the finite-dimensional POVM implies the security of the QKD protocol with the infinite-dimensional POVM [11, Lemma 6]. The security proof for the former protocol can then be obtained via any proof technique of one’s choice.

**Universal squasher:** This can be thought of as a generalisation of Ref. [34, 35] (and Fig. 2), where the exact equivalence is replaced with an approximate equivalence. In contrast to the proof-technique independent squashers,

TABLE I: List of squashers

<i>Type of squashing</i>	<i>Assumptions/ Conditions</i>	<i>Established Applicability</i>
Simple squashers [33, 37]	Protocol-dependent construction — need to check for each protocol separately (e.g. - equal loss in all detectors for active BB84 setup, no dark counts.)	Proof-technique independent [11, Lemma 6]
Universal squasher [36]	No dark counts, equal loss in all detectors, etc.	Phase error correction/EUR-based proof techniques [36]
Flag-state squasher [38]	Block-diagonal structure of POVM elements	EAT-based proof techniques [31, Appendix B], IID analysis [38, Theorem 1]
Dimension-reduction method [39]	None	EAT-based proof techniques <sup>a</sup> [41, Theorem 2], IID analysis [39]
Weight-preserving flag-state squasher [11, Section IV.B.1.]	Block-diagonal structure of POVM elements	Proof-technique independent [11, Lemma 6]

<sup>a</sup> Note that although this has been used for CV-QKD protocols, the extension to DV-QKD protocols is straightforward.

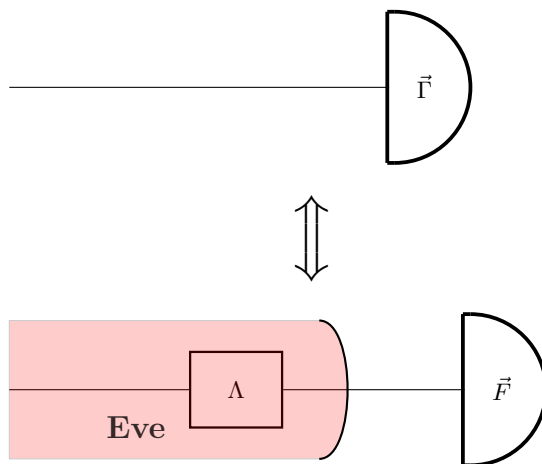

FIG. 2: The infinite-dimensional POVM  $\vec{\Gamma}$  can be modelled as a squashing map  $\Lambda$  followed by a finite-dimensional POVM  $\vec{F}$ . Giving the squashing map  $\Lambda$  to Eve lets us restrict our analysis to the finite-dimensional POVM  $\vec{F}$ .

the universal squasher only attempts to preserve *bounds* on the probabilities of relevant events during the squashing. In particular, it bounds the increase in the number of phase errors on replacing the infinite-dimensional measurement with a qubit measurement, which can then be used with the phase error correction/EUR proof-techniques.

**Flag-state squasher:** This is a generalisation of the simple squasher, that attempts to use the same idea depicted in Fig. 2. It attempts to make formal the intuition that although the detection setups are infinite-dimensional, the states typically live ‘mostly’ in a finite-dimensional subspace. Thus, the squashing map preserves the finite-dimensional subspace and fully announces the detection event in the rest of the space, formalised through classical states called ‘flags’. Such a map would always exist if the POVM is block-diagonal with blocks corresponding to the preserved finite-dimensional subspace, and the rest of the space. However, the reason this squasher is not proof-technique independent is that the squashing map cannot be completely ‘given’ to Eve. An additional bound on the weight of the state in the preserved subspace is required to ensure that this squasher is useful.

**Dimension-reduction method:** Although this originated as a way of generalising the flag-state squasher to CV-QKD protocols, where the POVM did not possess the required block-diagonal structure, it is more widely applicable to speed up numerical computations. This method can be thought of as a way to generically replace a semidefinite program (SDP) with an SDP where all the optimisation variables live in some smaller subspace. In the context of QKD,



this translates to rigorously replacing the (infinite-dimensional) single-round key rate SDP with a finite-dimensional key rate SDP to facilitate numerical computation. Thus, this technique is well-suited to proof-techniques that are easily able to reduce the analysis to a single-round quantity that must be numerically computed such as the EAT-based proof techniques.

Note that only the simple squashers and the weight-preserving flag-state squasher can be used independently of proof-technique. Also note that the flag-state squasher, dimension-reduction method, and the weight-preserving flag-state squasher need a way to bound on the weight outside some finite-dimensional subspace before they can be used<sup>27</sup>.

## 5. General common gaps in existing proofs

Having established an overview of the critical concepts necessary for QKD security proofs in the previous section, we now turn our attention to some common gaps in the existing literature. Despite significant progress in the field, certain aspects of security analysis remain incomplete or underexplored. In this section, we will highlight these gaps and discuss their implications.

### 5.1. Acceptance conditions

As outlined in Section 4.5, estimating the smooth min-entropy of states conditioned on the protocol accepting is a crucial step in security proofs<sup>28</sup>. To achieve this, as described in Section 4.5.1, the set of all possible states is divided into filtered and unfiltered states. The filtered states are required to satisfy the condition  $\Pr[\Omega_{\text{acc}}] \leq \varepsilon_{\text{AT}}$ , and the entropic bound is only derived for the unfiltered states. Crucially, constructing the set of filtered states must be done carefully, for a well-defined acceptance set, and using appropriate concentration inequalities to ensure  $\Pr[\Omega_{\text{acc}}] \leq \varepsilon_{\text{AT}}$ .

In particular, it does not suffice to simply say that the protocol accepts if the observed frequency distribution matches the expected honest behaviour. This would essentially be what has been termed a **unique-acceptance** or **single-point-acceptance** protocol, which only accepts if one specific frequency distribution is observed. Such a protocol is *highly* impractical, since it would abort nearly all the time. A practical acceptance set must include some “tolerance” to ensure that at least the honest behaviour is accepted with reasonable probability. While this issue might appear superficial, we highlight that the key rate computations in a number of works are implicitly only valid for a unique-acceptance protocol, even if not specified within the work itself.

Specifically, a common approach to compute finite-size key rates is to characterize the set of unfiltered states via some “neighbourhood” of some frequency distribution  $\mathbf{F}$ . However, if that frequency distribution  $\mathbf{F}$  consists solely of the honest behavior of the protocol, without a clear specification and analysis of an acceptance set, then the resulting key rate may effectively only be valid for a unique-acceptance protocol.<sup>29</sup> On the other hand, if that frequency distribution  $\mathbf{F}$  is a function of the observed values in the protocol, then this inherently describes a variable-length protocol, not a fixed-length one. In the latter case, a rigorous variable-length security proof is required for that protocol, as its security does not straightforwardly follow from fixed-length proofs (see Section 5.5).

Another common issue arises from the unjustified use of Gaussian concentration inequalities, such as  $10\text{-}\sigma$  confidence intervals (see, e.g. Ref. [42]), in characterizing the unfiltered set. This approach is problematic because the underlying random variables may not follow a Gaussian distribution. Thus, while this interval might be chosen very generously, it might still not satisfy the property of  $\Pr[\Omega_{\text{acc}}] \leq \varepsilon_{\text{AT}}$ . Hence, the structure for a proof as outlined in Section 4.5.1 is not satisfied anymore.

Furthermore, another potential problem is adding finite-size effects only to parts of the analysis, for example in Ref. [43], finite-size effects were only considered during the decoy-state analysis. This does not lead to correct key rates, as procedures like the privacy amplification or error verification step introduce further finite-size corrections which needs to be accounted for.

<sup>27</sup> These methods make formal the following intuition: although the detection setups are technically infinite-dimensional, the states entering the setup live ‘mostly’ in some finite-dimensional subspace. Thus, they require an additional way to bound the weight outside this finite-dimensional subspace.

<sup>28</sup> For fixed-length protocols, this acceptance condition is realized by checking whether the observed statistics fall within a predefined acceptance set.

<sup>29</sup> More precisely: for the proof structure in Section 4.5.1 for fixed-length protocols, any “useful” characterization of the set of unfiltered states would require this neighbourhood to be *strictly larger* than the acceptance set. However, as discussed above, any realistic acceptance set must *itself* be a nontrivial neighbourhood of the honest behaviour, and this neighbourhood is defined completely separately from the set of unfiltered states. Failing to take both of these effects into account may result in a security proof that is effectively only valid for a unique-acceptance protocol.

### 5.1.1. Choice of testing rounds

As already mentioned in Section 3.2.2, there are generally two options for determining test rounds; One can choose a sample set of fixed size, or independently and probabilistically assign each round for testing. In the latter case, the total number of test rounds is variable. The most straightforward mistake which could arise here, is that key rate formulas for the former case are used in the latter case, and vice versa.

In any version of the sampling procedure used in a security proof, it is crucial to apply the appropriate concentration inequalities (see Table II) that are valid for the specific scenario and accurately reflect the sampling process. For instance, Serflings inequality can be directly applied when randomly selecting a fixed-length subset of a classical string for testing. However, it can also be adapted to scenarios where each round is independently and probabilistically selected for testing, as long as the proof justifies that the statistics can be correctly analyzed with such an approach. Furthermore, when applying concentration inequalities, it is also important to clearly specify the random variables involved and verify that they satisfy the required conditions for the chosen inequality. For example, Hoeffdings inequality requires independent random variables, while Azumas inequality applies to martingales. Ensuring these conditions are met is essential for the validity of the security proof.

Additionally, depending on the proof technique, one may want to reduce certain finite-size correction terms to depend only on, say the number of key generation rounds (rather than total number of rounds). One scenario where this is useful is in using the asymptotic equipartition theorem (AEP) [44] to reduce multi-round state to single round quantities. However, such theorems are typically valid for scenarios with a fixed number of rounds. Hence, the AEP cannot be directly applied if, for example, we restrict the entropy estimation to (the variable number of) key generation rounds only. While this procedure can be made rigorous with special care, we do not go into its details here.

### 5.1.2. Iterative sifting

The theoretical analysis of most QKD protocols is undertaken under the setting where a fixed total number of rounds are used. Additionally, all public announcements are only performed after all signals have been sent and received. Therefore, Eve does not have access to public announcements while attacking the quantum channel.

Protocol implementations on the other hand may involve Alice and Bob performing announcements “on-the-fly”. That is to say, they may make announcements for a given round soon after the round is measured but before the end of the prepare-and-measure step<sup>30</sup>. Furthermore, they may use these announcements to determine when to stop sending and receiving signals. (For instance, Alice and Bob may send and receive signals until there are at least some number of detection events in a specific basis.) This aspect of protocol implementations and its variations are known as “iterative sifting”. The theoretical analysis of such protocols must be handled with care. Many works incorrectly analyze protocols with iterative sifting via methods that are only valid if all announcements take place *after* all signals sent are received. These issues were first pointed out by Ref. [45].

Protocols with on-the-fly announcements (but with a fixed number of total rounds) are easily handled in the GEAT framework [46], but then suffer from the sequential assumptions. For techniques to additionally handle the scenario where the total number of rounds also depends on these announcements, see Ref. [47] for methods in phase error correction (Section 6.2) and EUR (Section 6.1) frameworks.

## 5.2. Abort decisions

Many QKD security proofs do not discuss the authenticated classical channel in much detail, as there exist composable secure constructions of such channels. However, there is a technical issue that should be addressed here. Specifically, most such constructions do not give a channel that *always* successfully transmits the classical message, but rather one that may sometimes abort (informally: whenever Eve has attempted to modify the message). Therefore, a full protocol specification and security proof must discuss this possibility — clearly, the natural option is for the protocol to abort whenever the authentication procedure aborts, but the security proof should account for this accordingly.

Similarly, the protocol may also abort due to the error verification step, and this also should be taken into account when analyzing the state conditioned on the protocol accepting. This is more frequently addressed as compared to the above point, but is still sometimes overlooked.

---

<sup>30</sup> For example, Bob may announce the rounds he did not detect, so that Alice can immediately delete classical data she stored from those rounds rather than storing them until the end of the prepare-and-measure step.

### 5.3. IID assumptions

#### 5.3.1. Collective attacks are not a good approximation to practical restrictions

A common assumption made in some existing work is that Eve’s attack is IID, i.e., she interacts with Alice’s signal states in each round exactly the same way, independent of prior protocol rounds. We emphasise here that this assumption cannot be motivated by limiting Eve to currently practical attacks. That is, with currently available technology, it is easy to implement a non-IID attack.

For example, Eve could measure every odd pulse in the X-basis, and measure every even pulse in the Z-basis. This easily-implementable attack violates the IID assumption. Thus, it is important to prove security against generic attacks.

While there exist proof techniques [11, 48] that extend security proofs against IID collective attacks to coherent attacks, there are some conditions necessary to apply those techniques, and they usually change the security parameter and/or the key rate (see Section 6.3 for further discussion). Hence they cannot be generically used to claim that it suffices to analyze the IID case.

#### 5.3.2. Misuse of symmetry arguments

It was shown in Refs. [12, 13] that the symmetry properties of some protocols, such as the qubit BB84 and 6-state protocols, can be used to reduce the security analysis to a scenario where Alice and Bob hold IID Bell-diagonal states. Therefore, for such protocols it suffices to prove security against collective attacks.

However, care must be taken regarding the scope of this claim. Specifically, the symmetry analysis used in those works relied heavily on properties of genuine qubit systems, and does not appear to straightforwardly generalize to decoy-state protocols, which involve for instance high-dimensional states consisting of mixtures of different photon numbers. In particular, their results do not imply for instance that photon-number manipulations by Eve have to be IID — an example of an operation that Eve can certainly perform is to perform a photon-number-splitting attack in some rounds but not others, and the proof techniques in those works are insufficient to show that such possibilities can be excluded without loss of generality. Therefore, it is not correct to use the results of Refs. [12, 13] to claim that security proofs for decoy-state BB84 protocols can be reduced to collective attacks.

#### 5.3.3. Use of concentration inequalities

During the process of determining the secure key length, one is often required to bound certain quantities such as the phase error rate. These quantities are random variables and one only has access to a small sample from the test rounds. In the fixed-length scenario, one estimates e.g. the error rate based on the acceptance test, and in the variable-length case one derives bounds based on the observed statistics. For both cases, a common approach to construct intervals in which these quantities lie with high probability is to apply concentration inequalities from classical statistics — in Table II, we present the most commonly used ones along with their assumptions.

We highlight however that there are several critical points to note when applying these concentration inequalities:

**Ensuring assumptions are satisfied.** Each of these concentration inequalities is *only* valid under specific assumptions, thus when applying any of them in a security proof, we stress that it must be rigorously justified that the relevant assumptions are satisfied. For example, as previously stated in Section 5.1.1, when applying Hoeffding’s inequality, one needs to make sure that the random variables being considered are indeed independent. Serfling’s inequality technically requires a subset of fixed-length to be chosen for testing, but protocols may independently decide to test each round. The Serfling statement must then be modified accordingly to fit the protocol. Finally, Azuma’s inequality requires the random variables to be martingales, and hence one must construct appropriate random variables that can be proven to be martingales.

**Distinguishing fixed parameters from random variables.** When applying any of these concentration inequalities, it is important to keep track of which quantities are fixed parameters (i.e. constant values that describe the behaviour under a given attack, without any randomness) and which quantities are random variables, so that the concentration inequalities can be validly applied. This is particularly critical if trying to convert an analysis of single protocol rounds to a finite-size analysis of the full protocol. To take a specific example, if we denote the expected detection probability in round  $i$  (under some given attack) as  $q_i$ , then these values  $q_i$  are well-defined

parameters, but not all of the concentration inequalities in that table are related to those parameters. In particular, Serfling’s inequality does not involve those parameters  $q_i$  in any way. As for Azuma’s inequality, when applying it in security proofs, the martingales constructed are usually not the observed values themselves, but rather they are specific linear combinations of those values and some **conditional expectations**. Conditional expectations are random variables, *not* parameters; therefore, they are also not directly related to those parameters  $q_i$ , and Azuma’s inequality does *not* imply (for instance) that the observed detection frequency will lie close to the average of the  $q_i$  values.

**Remark 5.1.** *One can construct simple counterexamples that demonstrate how failing to track the above points can lead to incorrect conclusions. For instance, consider  $n$  binary random variables  $X_i$  with the following simple distribution: with probability  $1/2$  we have  $X_i = 0$  for all  $i$ , and with probability  $1/2$  we have  $X_i = 1$  for all  $i$ . In that case, the expected value of each  $X_i$  is simply  $E[X_i] = 1/2$ ; however, it is clear that the observed sum  $\sum_i X_i$  is always either 0 or  $n$ , so it is never close to its expected value  $E[\sum_i X_i] = \sum_i E[X_i] = n/2$ . Therefore, no concentration inequality can claim that the sum  $\sum_i X_i$  converges to its expected value with high probability in this scenario, and any such claim that does not impose enough conditions to rule out this scenario is hence necessarily incorrect.*<sup>31</sup>

TABLE II: List of Commonly used Concentration Inequalities.

<i>Inequality</i>	<i>Conditions</i>	<i>Statement</i>
Hoeffding’s Inequality [49, Theorem 2]	$X_1, \dots, X_n$ independent random variables with $a_i \leq X_i \leq b_i$ .	$\Pr[ \sum_i (X_i - E[X_i])  \geq t] \leq 2 \exp\left(-\frac{2t^2}{\sum_i^n (b_i - a_i)^2}\right)$
Binomial bounds	$X_1, \dots, X_n$ IID Bernoulli random variables, then $\sum_i X_i$ is a binomial random variable	Concentration inequalities given by cumulative distribution function of binomial random variable
Serfling inequality [50, Corollary 1.1]	$X_1, \dots, X_n$ drawn randomly without replacement from values $x_1, \dots, x_N$ for $n \leq N$	$\Pr[\sum_i X_i - n\mu \geq nt] \leq 2 \exp\left(-\frac{2nt^2}{(1 - f_n^*)(b-a)}\right)$ , for $\mu = \sum_i x_i/n$ , $f_n^* = \frac{n-1}{N}$ , $a = \min_i x_i$ and $b = \max_i x_i$ .
Azuma’s inequality <sup>a</sup> [52]	$\{X_i\}_{i=0,1,\dots}$ a martingale and $ X_i - X_{i-1}  \leq c_i$ for all $i \geq 1$	$\Pr[ X_n - X_0  \geq t] \leq 2 \exp\left(-\frac{t^2}{2\sum_i^n c_i}\right)$

<sup>a</sup> Often, the tighter Kato’s inequality [51] is used in place of Azuma’s inequality.

#### 5.4. Error correction

Alice and Bob must implement some amount of error correction to rectify the error in their data. This invariably leaks information to Eve, and the security proof must correctly account for such information leakage. This leakage must be analyzed carefully. See Section 3.4 for a discussion on the variety of possible implementations, which we recall in brief below. As before, we assume that one party has already obtained the pre-amplification string, and the other party is attempting to obtain the same string.

##### 5.4.1. Implementation choices

**One-way error correction.** Alice holds the pre-amplification string, and sends some number of bits to Bob, who uses this together with his private data to produce a guess for Alice’s pre-amplification string.

**Reverse reconciliation.** A slightly different form of one-way error correction, where Bob holds the pre-amplification string and sends classical data to Alice. The security proof must account for the fact that Bob holds the pre-amplification string in this case; see Section 5.4.2 below.

<sup>31</sup> Regarding the specific inequalities we list here: Hoeffding’s inequality and binomial bounds require independent random variables and hence do not apply to this scenario; whereas Serfling’s inequality and Azuma’s inequality do not discuss convergence to single-round parameters or expected values, and hence only provide results of a rather different nature from this claim.

**Two-way information reconciliation.** More complicated protocols that involve multiple rounds of communication between Alice and Bob may be employed. Depending on the situation, this may involve a scenario where either one of Alice or Bob holds the pre-amplification string, which is then followed by a two-way information reconciliation protocol. Some examples of such protocols are Cascade [21] and Winnow [53]. Note that this may also cover more elaborate scenarios where the pre-amplification string itself is obtained through the interaction between Alice and Bob.

#### 5.4.2. Technical statement for entropy based techniques

For entropy based proof techniques that go through the Leftover Hashing Lemma, the leakage due to error correction is typically analyzed using a chain rule of the form:

$$H_{\min}^{\bar{e}}(\mathbf{S}|C_{\text{EC}}\mathbf{E})_{\rho} \geq H_{\min}^{\bar{e}}(\mathbf{S}|\mathbf{E})_{\rho} - \log(|C_{\text{EC}}|), \quad (14)$$

where  $\mathbf{S}$  denotes the register storing the pre-amplification string, and  $\mathbf{E}$  denotes all of Eve’s registers excluding the hash-choice for PA, and excluding the communication during error correction and error verification ( $C_{\text{EC}}$ ). Thus, Eve’s uncertainty about the pre-amplification string is reduced by at most  $\log(|C_{\text{EC}}|)$ . To use this chain rule for the analysis of a general error correction protocol,  $\log(|C_{\text{EC}}|)$  is given by *the number of bits needed to “encode” all possible transcripts* of the error correction protocol.

We emphasize the fact that in order to combine the above inequality with the Leftover Hashing Lemma, it is important that we are analyzing the smooth min-entropy of the pre-amplification string  $\mathbf{S}$  specifically (conditioned on various other registers), not some other strings, such as the raw data or any other “intermediate” string values produced during the processing steps. In particular, this means that for protocols with reverse reconciliation (where Bob is the first party to hold the pre-amplification string), this means that typically it should be applied to *Bob’s* pre-amplification string, not Alice’s.

**Remark 5.2.** *In order to use this inequality in QKD security proofs, we typically apply it on states conditioned on specific events. For example, for fixed-length protocols one considers the state  $\rho_{|\Omega_{\text{acc}}}$ . Then  $|C_{\text{EC}}|$  is the total number of values this register can take conditioned on  $\Omega_{\text{acc}}$ . For variable-length protocols, one may consider events corresponding to various observations during the protocol run, and determine the error correction protocol parameters (and therefore  $|C_{\text{EC}}|$ ) based on the observed event.*

#### 5.4.3. Computing the cost

The computation of  $\log(|C_{\text{EC}}|)$  is straightforward, but depends on some important details of the error correction protocol that is implemented.

1. **One-way EC with fixed number of bits:** Since the number of bits leaked  $\lambda_{\text{EC}}$  is fixed,  $\lambda_{\text{EC}}$  many bits are enough to encode all possible transcripts.
2. **One-way EC with maximum number of bits:** Here the number of bits leaked is less than or equal to  $\lambda_{\text{EC}}$ . It turns out that a  $\lambda_{\text{EC}} + 1$  bit register is enough to encode all possible transcripts<sup>32</sup>.
3. **Two-way EC:** The total number of possible transcripts depends on the exact protocol specifications of the two-way interactions (including number of bits in each round, and total number of rounds). A rigorous analysis of error correction must provide this computation along with the protocol specification. For an example of the subtleties that may arise in such scenarios, see Ref. [54].

#### 5.4.4. Using the actual number of bits leaked

In many works, it is stated without proper arguments, that one can use the number of bits *actually used* by the error correction protocol in the above calculations. In fact such a claim implicitly suggests that one is implementing a variable-length protocol (see below), and therefore one must prove security for variable-length protocols. Intuitively, such scenarios leak additional information to Eve beyond the calculations described above. To see this, note that

---

<sup>32</sup> Since  $2 + 2^2 \dots 2^{\lambda_{\text{EC}}} \leq 2^{\lambda_{\text{EC}}+1}$ .

Eve can simulate the error correction protocol on all possible combinations of Alice and Bob’s data, and rule out combinations that do not lead to the number of bits of error correction actually observed. Thus, even for variable-length protocols, the number of bits to be used for error correction in current security proofs is completely determined by the public announcements during the variable-length decision.

**Remark 5.3.** *Formally, the difficulty in analyzing this situation shows up in the observation that in order to only subtract the number of bits actually used from the smooth min-entropy term, one has to condition on the event that “a certain number of bits observed during error correction”. It turns out that obtaining a bound on the smooth min-entropy of the state conditioned on such an event is difficult.*

#### 5.4.5. Information leakage in phase error correction frameworks

Information leakage due to error correction communication is handled differently in phase error correction based proofs. In particular, the argument does not involve the use of entropic chain rules. Many early works based on the phase error correction proof framework required the error correction information to be uncorrelated with the pre-amplification string, for which the protocols were required to one-time pad the error correction announcements. This requirement was later removed in some follow-up works [55, 56]; however, note that such proofs have currently only been provided for one-way error correction procedures in which the announced bits are computed by applying a *linear* function to the pre-amplification string (see Section 6.2). In comparison, proofs treating error correction announcements via the above chain rule (Eq. (14)) allow for more general protocols to be analyzed.

#### 5.4.6. Error verification and the correctness condition

As previously discussed in Section 4.3, care is necessary when interpreting the guarantees of error verification. In particular, when considering error verification based on 2-universal hashing, the hashing procedure only offers the guarantee that conditioned on the pre-amplification strings being different, then the probability that their hashes match is small. We stress that this is *not* the same as a statement that conditioned on the hashes matching, the probability of the pre-amplification strings differing is small —these two probabilities are *a priori* entirely unrelated, but conflating them is a common mistake. It is in fact possible to construct explicit counterexamples to the latter statement, i.e. attacks by Eve such that

$$\Pr[\text{pre-amplification strings differ} \mid \text{error verification accepts}] \approx 1. \quad (15)$$

Hence the pre-amplification strings may differ with high probability *even conditioned on the hashes matching*.

Fortunately, the correctness condition in the composable security definition does not require a bound on the latter probability; it only requires that the probability of the pre-amplification strings differing *and* the hashes matching is small. As noted in Section 4.3 (Eq. (10)), a bound on the former probability is indeed sufficient to show that the correctness definition is satisfied. The framework of composable security then ensures that we have the desired composable properties of the protocol, despite the fact that even conditioned on the hashes matching, Alice and Bob’s keys may differ with high probability.

### 5.5. Variable-length protocols

Many of the existing rigorous security proofs for QKD are restricted to the case of “fixed-length” protocols. Such protocols involve a predetermined condition for accepting or aborting the protocol (most critically during the acceptance test, though the protocol may also abort during later steps such as error verification). If the protocol accepts, a final key of fixed length is produced; otherwise, if the protocol aborts, no key is produced. For such protocols, it is necessary for the acceptance conditions to be chosen *before* the protocol is run.

In variable-length (also known as “adaptive-length”) protocols, the user is allowed to adjust the amount of error correction to be performed, and the length of the final key that is to be produced, based on the observations made during the protocol. Such protocols are relevant for practical implementations, since they remove the requirement of choosing a well-crafted acceptance condition (which typically requires accurate characterization of the honest behaviour of the channel).

Proving the security of variable-length protocols requires new arguments, i.e. it does not directly follow from the security proof from fixed-length protocols. A common mistake in QKD literature involves using a security proof for



fixed-length protocols in a variable-length implementation. One way this mistake is made is by allowing users to choose their acceptance conditions after looking at the observations.

For security proofs of variable-length protocols see Refs. [11, 30] for an approach involving the use of the postselection technique [48], see [57, Supplementary Note A], [58, Appendix B, F] for a security proof in the EUR framework, and [59, Chapter 3] [60] for the phase error correction based methods.

## 5.6. Miscellaneous

### 5.6.1. Resources used in QKD

Most QKD security proofs assume that Alice and Bob each locally have access to ideal RNGs. However, an ideal RNG is usually a mathematical abstraction that is not realized in practice. One conceptually simple way to address this issue is to use an RNG device that is accompanied by a composable security proof, so that as long as the device satisfies the model assumptions in that security proof, the composable security framework implies that we can simply analyze the QKD protocol as though the RNG is ideal, then add the “error parameter” from the composable security analysis of the RNG device. A more elaborate possibility would be to perform the QKD security proof while incorporating an in-depth analysis of the details and imperfections of the real RNG, but this may be fairly challenging. Passive QKD can serve as an approach to reduce the number of random bits required from the RNGs, but requires the devices to be sufficiently characterized to implement the desired distributions.

Similarly, when considering the authenticated classical channels, in real QKD implementations one does not truly have access to ideal authenticated classical channels. Again, however, since there exist reasonably simple protocols to construct authenticated classical channels with composable security (given short pre-shared keys), one can first derive the QKD security proof assuming ideal authenticated classical channels, then add the “error parameter” from the composable security definition accordingly. (As mentioned in Section 5.2 above, we re-emphasize that the QKD security proof must still account for the possibility of authentication aborting.)

While the RNGs and the authenticated classical channels can in principle both be constructed with information-theoretic security, for some QKD implementations one might instead wish to use constructions that only have computational security. There exist works considering this possibility and its connection to a concept known as **everlasting security**, but that will not be a focus of this work.

### 5.6.2. Variable-length of pre-amplification string

A subtle issue arises due to a gap between theory and implementation of sifting and privacy amplification in QKD protocols. This gap is applicable to proof techniques reducing the analysis to a single-round entropic quantity, such as the postselection technique followed by an IID security proof, and EAT / GEAT based methods. In particular, it is avoided by EUR and phase error correction based methods.

**Theory.** In theoretical analysis, sifting is typically modeled as setting the pre-amplification string register to a 0 or  $\perp$  for each round that is discarded, which leads to the pre-amplification string register having a fixed length. Privacy amplification is then implemented by two-universal hashing on this register (of fixed-length) to some  $l$  bits. Note that if the discarded rounds are set to  $\perp$ , then the hashing procedure is no longer applied to binary strings.

**Implementation.** In practice, sifting is often implemented by physically discarding the round, which leads to the pre-amplification string register having a variable number of bits. Then, privacy amplification is done by first looking at the number of bits in the pre-amplification string, and *then* implementing 2-universal hashing from those many bits to  $l$  bits. This approach is preferred since it allows users to apply hashing on smaller, binary strings.

This difference constitutes a clear gap between the theoretical model and the practical implementation. The gap is further exacerbated by the fact that the implemented protocol does *not* represent a valid two-universal hashing procedure on the pre-amplification string register<sup>33</sup>. This issue was first pointed out and addressed in Ref. [30, Section V], where a variant of the Leftover Hashing Lemma that is applicable to the variable-length pre-amplification strings case was proven. In particular, it was shown that as long as the positions of the discarded rounds are publicly announced, the theoretical analysis of the following three scenarios are equivalent:

1. Discarded rounds are mapped to  $\perp$ .

---

<sup>33</sup> For instance, consider two all-zero strings of different lengths. If a linear 2-universal hash is applied on these strings, the probability of collision is 1, even though the input strings are different.

2. Discarded rounds are mapped to 0.
3. Discarded rounds are actually discarded.

Thus a security proof using scenario (1) or (2), is applicable to an implementation with scenario (3).

Note that the above problem does not arise in EUR and phase error correction based proof techniques. This is because in these frameworks, the pre-amplification string is only generated from detected signals. If the pre-amplification string is of variable length, then one can separately apply the Leftover Hashing Lemma for each possible length, and obtain a security proof similar to the one for variable-length protocols [58, Remark 17]. Alternatively, some protocols choose a random subset of fixed length for the pre-amplification string on which privacy amplification is done.

### 5.6.3. Conditioning on well-defined events

As discussed earlier in Section 4.5, when proving rigorous security for QKD protocols, it is crucial to compute entropies and probabilities for states properly conditioned on relevant events. Conditioning can significantly alter the values of these quantities. Furthermore, it is important to ensure that the events we condition on are well-defined. Specifically, a well-defined event is one where there exists (in principle) a classical register that determines whether or not the event occurred.

This issue becomes particularly subtle when using techniques like the EUR, which considers post-measurement states obtained via *different* measurements on the same state (see Section 6.1 for more details). For instance, one typically needs to bound the entropy of a state conditioned on acceptance (and passing error verification). However, the EUR statement cannot be applied directly to a state conditioned on passing error verification because this event is not well-defined until the state has been measured in one basis. Once measured in this basis, the state obtained by measuring in the complementary basis (which is needed for the EUR statement), becomes ill-defined. Such issues must be suitably addressed.

## 6. Families of security proofs

In the previous section, we identified common gaps in existing QKD security proofs. Building on that discussion, we now review the primary finite-size security proofs against coherent attacks for decoy-state BB84 as presented in the literature. While tremendous progress has been made, significant gaps and limitations remain, which we aim to highlight in this section. Rather than examining each proof in detail, we focus on the foundational works that serve as the basis for subsequent analyses and, consequently, inherit the shortcomings of the original.

It is important to note that while we point out issues in many of these works, they represent significant advancements in the proof techniques available at the time. Many of the gaps and limitations we discuss were later addressed by subsequent research, which greatly benefited from the simple fact that it was developed at a later stage, with the advantage of building upon prior insights and refinements.

### 6.1. Proofs based on entropic uncertainty relations

Proofs that rely on the entropic uncertainty relations [61] utilize the following statement to obtain a bound on the smooth min-entropy of the pre-amplification string: that for any state  $\rho_{A^m B^m \mathbf{E}}$ ,

$$H_{\min}^{\bar{\epsilon}}(Z_A^m | \mathbf{E})_{\mathcal{E}_Z(\rho)} + H_{\max}^{\bar{\epsilon}}(X_A^m | B^m)_{\mathcal{E}_X(\rho)} \geq mc_q \quad (16)$$

where  $\mathcal{E}_Z(\rho)$  is a channel that measures the  $A^m$  system in the  $Z$  basis, and  $\mathcal{E}_X(\rho)$  is a channel that measures the  $A^m$  system in the  $X$  basis, and  $c_q$  is a parameter that depends on these measurements POVMs<sup>34</sup>. Here, Alice's measurement POVMs and her reduced state are obtained from the source-replacement scheme (see also Section 4.1).

In the actual protocol, the  $Z$  measurements are performed, which determines (a part of) the pre-amplification string whose min-entropy we wish to bound. The max entropy term is then suitably bounded by obtaining an estimate (upper bound) on the number of “phase errors”. This refers to the number of errors corresponding to (fictitious)

<sup>34</sup> The  $Z$  and  $X$  basis here need not be taken literally. One can use the EUR statement for *any* two POVMs, one corresponding to  $Z$  and  $X$ . (To obtain a useful statement, one must ensure that  $c_q > 0$  for the two POVMs considered). For the BB84 protocol with ideal source, these correspond to the canonical  $Z$  and  $X$  basis measurements.

measurements, where Alice and Bob use a different basis for the measurements than the one in the protocol. Note that one typically only applies the EUR analysis on a part of the pre-amplification string  $\mathbf{S}$ . Thus, one must also relate the smooth min-entropy obtained via the EUR analysis to the min-entropy of the pre-amplification string. This is done with the use of suitable chain rules.

When working within EUR based security proofs, the following unique factors must be considered

1. In order to use the EUR statement, one must properly define the state to which it is applied. Typically, we only apply the EUR statement on single-photon rounds used for key generation (typically, these are the detected rounds where Alice sent a single-photon and both Alice and Bob measured in the same basis). This needs to be explained rigorously, and can be done by reformulating the measurement procedure to consist of several measurement steps. This is somewhat technical, and is undertaken in Refs. [4, 58, 62].
2. As outlined in Section 5.6.3, we require min-entropy bounds on states conditioned on specific events, which must be well-defined. The use of the EUR statement introduces additional complications to this task, as conditioning on events that presuppose a fixed measurement basis can be problematic. For example, conditioning on the success of error verification poses problems, since this event requires measurements in a particular basis.

The basic approach to address these issues is to consider states which are conditioned not on the protocol’s actual events, but on related, well-defined events. The EUR statement can be rigorously applied on states conditioned on these related events. The resulting entropic bounds can then be translated back into bounds on states conditioned on the actual events in the protocol [58, 63].

3. In order to obtain an estimate of the phase error rate, most works require the following assumption on the detection setup: that the probability of detection is independent of Bob’s basis choice. This is equivalent to demanding all detectors have exactly identical efficiencies and dark count rates. For passive setups, this additionally requires the beam splitter to be perfectly balanced. This assumption is known as “basis-independent loss”, and its violation is known as “basis-efficiency mismatch” or “detection-efficiency mismatch” in the literature. Due to this assumption, almost all works using the EUR for practical protocols are not applicable to real-world scenarios for standard QKD. However, this assumption is not a problem for MDI-QKD, where the detectors are completely untrusted and assumed to be in Eve’s control. Thus many works utilizing this proof technique appeal to MDI-QKD as a method to remove this assumption, and close all detector side-channels.

Recently, a method to remove this assumption for EUR and phase error correction based security proofs for active basis choice BB84 was obtained in Ref. [58]. However, it has not yet been combined with other works that address source-imperfections, iterative sifting etc. We discuss this in greater detail in Section 6.1.3.

Note that a highly formal proof using the EUR statement for fixed-length qubit BB84 can be found in Ref. [4].

#### 6.1.1. *Lim et al., 2014 [64]*

The first security proof for decoy-state BB84 using the entropic uncertainty relations was obtained in Ref. [64]. A major follow up work on this result that reduces the number of decoy intensities required for the protocol is Ref. [65], which we discuss in greater detail in Section 6.1.2. The following works [65–79] base their security analysis on Ref. [64]<sup>35</sup>.

The proof in Ref. [64] goes through the entropic uncertainty relations approach, and has the following shortcomings. Note that despite these shortcomings, the main essence of the result remains true after suitable fixes [58]:

1. The proof does not condition on relevant events (see Section 5.6.3), which presents a technical issue and raises questions about the application of certain chain rules.
2. The protocol described is a variable-length protocol, however the security definition for variable-length protocols is not used (see Section 5.5).
3. The proof implements a protocol with iterative sifting and announcements, but does not adequately address it in their sampling estimates for the phase error rate (see Section 5.1.2). The estimate on the phase error rate is obtained via Ref. [80], and goes through a Taylor approximation step. Thus the estimate is not a true bound.

---

<sup>35</sup> We have grouped together works that rely on [64, 65] due to the similarities in these two works

4. The proof claims that the error correction cost can be computed from the number of bits actually leaked, without proper justification (see Section 5.4.4).
5. It does not properly differentiate between random variables, fixed parameters and observed values of random variables (see Section 5.3.3). Moreover, it does not properly specify the state on which the EUR statement is applied.

Additionally, this work requires the source preparation to be perfect. However, there are several follow up works on the topic of source imperfections, that provide methods to obtain a suitable bound on the phase error rate, even in the presence of source imperfections [81–84]. It also considers active basis choice by Bob, and assumes that the probability of detection in Bob’s setup is independent of basis. This assumption is a core issue for all EUR and phase error correction (see Section 6.2) based proofs for standard QKD, and was removed recently in Ref. [58].

#### 6.1.2. Rusca et al., 2018 [65]

A major improvement to Ref. [64] was shown in Ref. [65], by reducing the number of total decoy intensities needed in the protocol from three to two. The analysis in Ref. [65] follows that of Ref. [64], and hence inherits all the shortcomings outlined above in Section 6.1.1. However it adds the following issues:

1. The protocol in Ref. [65] requires the knowledge of the number of errors in the key generation rounds. These are not announced in the protocol, and the paper does not specify how Alice and Bob obtain this information.

A straightforward approach would be for Bob to compute the number of errors in the key generation data, assuming that error correction has succeeded. However, this relies on the success of error correction, and the security analysis must rigorously account for this dependency.

Alternatively, the error rate could be estimated through sampling by using the observed errors in the testing fraction of  $Z$ -basis rounds. This introduces additional finite-size effects which must be accounted for.

2. Moreover, if Bob computes the error rate in the  $Z$  basis through error correction, even the acceptance event depends on a specific measurement basis. This introduces additional complications when conditioning on these events, beyond the complications due to conditioning on error verifications outlined in Section 6.1. For an approach to resolve this complication, see Ref. [63].

#### 6.1.3. Tupkary et al., 2024 [58]

The main focus of Ref. [58] was to provide a method to estimate the phase error rate *without* requiring the basis-independent loss assumption on detectors (see Section 6.1). Along the way, Ref. [58] points out and addresses several issues in Ref. [64] discussed in Section 6.1.1. In particular, it conditions on relevant events, rigorously proves the security of a variable-length protocol, does not implement iterative-sifting, obtains a phase error rate bound without approximations and determines the error correction cost from public announcements during the variable-length decision. Moreover, it carefully differentiates between random variables and observed values, clarifies the use of Hoeffding’s inequality in the decoy analysis, and rigorously specifies the state on which the EUR statement is applied.

However, Ref. [58] is still not completely general. In particular, it is limited to the decoy-state BB84 protocol with perfect signal states, active basis choice on Bob’s side, and detectors that are “close” to satisfying the basis-independent loss assumption. While there do not appear to be fundamental reasons why these issues cannot be addressed in the future, these arguments do not currently exist in the literature.

#### 6.1.4. Wiesemann et al., 2024 [63]

A security proof for decoy-state BB84 was recently obtained in Ref. [63], which presents a pedagogical treatment of the proof techniques from Lim et al [64] and Rusca et al [65]. The first version of this work inherited all the shortcomings of Refs. [64, 65]. This was then modified in later revisions to address most of the issues outlined in Sections 6.1.1 and 6.1.2. In particular, the second version considers a fixed-length protocol, avoids iterative announcements, and conditions on relevant events. It uses a finite-size sampling bound that is a true bound (does not go through any approximations), and determines error correction cost based on the announcements and not from the number of bits actually leaked. The main drawback is the assumptions of basis-independent loss on the detectors, active basis choice by Bob, and the assumption of ideal sources. Moreover, Ref. [63] is missing some key details in some parts of the

argument — it does not properly differentiate between random variables and constants, it does not properly specify the state on which the EUR statement is applied, and it does not explain the application of the Hoeffding’s inequality in the decoy analysis.

## 6.2. Phase error correction approach

The phase error correction based proof technique [85, 86], sometimes referred to as a proof based on complementarity, is a proof technique that is significantly different from the other QKD proof techniques discussed in this report. This proof technique is based on the original Shor-Preskill [87] and the GLLP [18] proofs. The phase error correction based proof technique does *not* proceed by bounding the (smooth min-)entropy of the state, and using the Leftover Hashing Lemma (Section 4.4). Instead, the security statement is related to the probability of a particular (virtual) phase error correction protocol succeeding. This, in turn is related to an upper bound on the number of “phase errors”.

The number of phase errors, in the form presented in [85, 86] can be qualitatively understood as follows, though we do not aim to present a rigorous definition here. Suppose we have some state of the form  $\rho_{Z_A^m B^m \mathbf{E}}^{(Z)} = \mathcal{E}_Z(\rho_{A^m B^m \mathbf{E}})$ , where  $A^m$  consists of  $m$  qubit systems, and  $\mathcal{E}_Z$  is a channel that measures the  $A^m$  system in the  $Z$ -basis. Now consider instead the state  $\rho_{X_A^m B^m \mathbf{E}}^{(X)} = \mathcal{E}_X(\rho_{A^m B^m \mathbf{E}})$  where  $\mathcal{E}_X$  is a channel that measures the  $A^m$  system in the  $X$ -basis. The number of phase errors is, informally, quantified by how many bits Alice would need to send Bob (holding system  $B^m$ ) in the latter state in order for him to guess the string  $X_A^m$  with high probability.

Refs. [85, 86] showed that if there exists some *constant*  $N_{\text{const}}^{\text{err}} \in \mathbb{N}$  that bounds the number of phase errors with high probability, then hashing<sup>36</sup> the string  $Z_A^m$  in the state  $\rho_{Z_A^m \mathbf{E}}^{(Z)}$  to a length determined by  $N_{\text{const}}^{\text{err}}$  results in the output being nearly uniform and decoupled from  $\mathbf{E}$ , roughly analogous to the Leftover Hashing Lemma.<sup>37</sup> We highlight however that this result by itself does not constitute a security proof for a QKD protocol. This is firstly because of issues similar to those raised in Section 4.5 — for instance, one needs to address the question of whether the states being analyzed are conditioned on various events (such as the protocol accepting or the key length being chosen to be a particular value); also, it is usually impossible to find a *constant* upper bound  $N_{\text{const}}^{\text{err}}$  on the number of phase errors, similar to the problem of finding a constant lower bound  $\kappa_{\text{const}}$  on the smooth min-entropy. Furthermore, since the proof technique only analyzes hashing the string  $Z_A^m$  specifically, to analyze a QKD protocol it must be explicitly justified that the pre-amplification string  $\mathbf{S}$  can be written in the form  $\mathbf{S} = Z_A^m$ , in some state of the form  $\mathcal{E}_Z(\rho_{A^m B^m \mathbf{E}})$  such that the number of phase errors can also be suitably analyzed. Approaches to handle these issues have been presented in [60, 62, 88], though care is needed in interpreting their results; we discuss this further in Section 6.2.1.

There are also some other features unique to phase error correction based proof techniques:

1. This proof technique requires that the hash family used is linear. Moreover, the proof technique requires that the hash family is dual 2-universal [89]. These conditions are rather technical and unique to this proof technique, hence we do not discuss them further in detail — we note simply that Toeplitz matrices and random binary matrices are both dual 2-universal hash families.
2. The original proofs in Refs. [85, 86] required that the error correction information used in the protocol be one-time padded. This allows the error correction to be dealt with separately from the secrecy condition. More recent works [55, 56] allows for more sophisticated error correction procedures that remove the need for this one-time padding, though the error correction procedures then need to satisfy certain properties. For instance, Ref. [55] only analyzes the case where the error correction procedure consists of applying a linear map to a string Alice holds, then announcing a subset of it for error correction while retaining the rest as the pre-amplification string. Note that proof techniques based on the Leftover Hashing Lemma can account for the error correction information being revealed (without one-time padding) by instead using entropic chain rules as described in Section 5.4.2.

The above descriptions were a fairly generic discussion of the phase error correction approach. We now turn more specifically to the case of security proofs for decoy-state protocols. We highlight in particular that it is important for such a proof to explicitly address the point noted above, of describing the pre-amplification string via measurements on qubit systems in a manner compatible with analyzing the phase errors, despite the fact that the decoy-state protocol involves various mixtures of states of different photon numbers.

<sup>36</sup> There are some restrictions in the hash families considered in this proof; we shall discuss this point shortly.

<sup>37</sup> There are a number of similarities between this approach and EUR-based approaches when constructing a QKD security proof, as discussed further in Ref. Section 6.2.2.



6.2.1. Koashi, 2006 [62], Hayashi and Nakayama, 2014 [88]

The first work to outline an approach for using phase error correction to prove security of decoy-state BB84 against coherent attacks is Ref. [62]<sup>38</sup>. It thus forms the primary basis for further decoy-state security proofs in the phase error correction approach, though by itself it does not constitute a full finite-size security proof. This is because it gives a key length formula (below Eq. (9)) that depends on the number of single-photon phase errors, and number of zero and single-photon detection events, but it does not perform a finite-size analysis that bounds these quantities. (Qualitatively, it addresses some of the difficulties raised in the preceding section by arguing that the variable-length secrecy definition (Eq. (7)) can be satisfied if the variable key length is chosen as a function of the number of phase errors, though it does not address how the latter should be computed or estimated in practice.)

The subsequent work [88] performed a more detailed finite-size analysis to bound the relevant quantities, and is the first such attempt at a full decoy-state security proof, serving as a basis for subsequent works such as [90, 91]. Note that it uses a different argument to obtain the key length formula in Ref. [62] mentioned above<sup>39</sup>; however, the argument appears somewhat incomplete — specifically, it does not give a detailed justification of how multi-photon pulses can be replaced with rounds with a different “effective” phase error rate. Furthermore, it also does not provide a detailed explanation of why some statistics gathered in the protocol can be modelled using a hypergeometric distribution. (While it describes how to analyze a hypergeometric distribution in terms of a binomial distribution, it does not appear to justify why the statistics should in fact follow a hypergeometric distribution.) Similar to many EUR-based security proofs, it also relies on the basis-independent loss assumption.

Note that the gap in Ref. [62], i.e., the rigorous finite-size estimation of the single (and zero) photon detection events and single-photon phase error events, is a critical ingredient of EUR based proofs as well, as we shall discuss below. Thus, the estimation from Refs. [58, 64] could also be used to complete this security proof. Although it is not hard to combine these results from the various existing works, we do not know of any self-contained decoy-state security proof in the phase error correction approach.

6.2.2. Comparisons with EUR

As mentioned earlier, there are some similarities between the EUR-based security proof approaches and the phase error correction-based security proof approaches, though there are also some differences, which we shall also elaborate on here. First, we note that Ref. [92, Theorem 1] showed that a bound on the smooth min-entropy of a classical string conditioned on some side-information gives a bound on the failure probability of a corresponding phase error correction protocol, in an attempt to bridge the gap between Leftover Hashing Lemma based approaches and phase error correction based approaches. However, this connection is only made in terms of statements similar to the result in Refs. [85, 86], which as mentioned above, does not constitute a full security proof for a QKD protocol (as it is only a statement about some abstract state assumed to satisfy certain properties, rather than the pre-amplification state in a QKD protocol).

In light of this, we highlight that there are some differences between how existing decoy-state security proofs based on the two approaches proceed. In particular, the proofs based on phase error correction involve expressing the *entire* pre-amplification string  $\mathbf{S}$  as the output of  $Z$ -basis measurements on some qubit systems, despite the fact that many of the bits in  $\mathbf{S}$  usually correspond to Alice sending vacuum or multi-photon states — this requires a suitably formulated source-replacement argument. In contrast, existing EUR-based security proofs often use suitable chain rules to decompose the smooth min-entropy of  $\mathbf{S}$  into terms corresponding to vacuum, single-photon, and multi-photon events, and only apply the EUR on the single-photon component. In other words, the registers on which (virtual)  $Z$ -basis or  $X$ -basis measurements are analyzed are different in the two approaches. While it may be possible to connect the approaches, we do not know of an existing self-contained work that formalizes such a connection.

Still, we note that via the analysis in Ref. [62], it is possible to reduce the main task in a phase error correction based security proof to the question of finding a “statistical” bound on the number of phase errors in detected rounds corresponding to single-photon emissions by Alice. In existing EUR-based security proofs, one computes bounds on the same quantity in order to bound  $H_{\max}^{\epsilon}(X_A^m|B^m)_{\mathcal{E}_X(\rho)}$  on the detected single-photon component. Thus, one major non-trivial step in the usage of these proof techniques is the same — upper bound the number of phase errors (in rounds where Alice emitted a single photon and it was detected) through statistical arguments. As a result, a lot of the factors that must be considered for EUR based security proofs also apply to phase error correction based proofs, as we now explain.

<sup>38</sup> Ref. [60] also provided a security proof for variable-length protocols using phase error correction, using similar ideas, but the analysis was restricted to fully qubit BB84 rather than decoy-state BB84.

<sup>39</sup> Specifically, Eq. (7) in Ref. [88] corresponds to Eq. (9) in Ref. [62].



For instance, one must properly define the state on which the number of phase errors is bounded. Typically, an upper bound on the number of phase errors in the detected single-photon rounds is obtained. This is justified via breaking up the measurement into a two step process where the first step decides whether or not the round will be detected, followed by the rest of the measurement which dictates the final measurement result when the round is detected [4, 58, 62]. While this argument works straightforwardly when all detectors have the same detection efficiency, this must be modified [58] in the case when the different detectors have varying efficiencies, as previously discussed in Section 6.1. For passive setups, this additionally requires the beam splitter to be perfectly balanced, and there is no currently known modification that can be used for more general passive setups.

### 6.3. Postselection technique

The postselection technique is a proof technique that reduces the analysis of coherent attacks to the analysis of IID collective attacks. It is composed primarily of three parts:

1. First, given a permutation invariant protocol, the permutation invariance property is used to reduce the analysis from all possible states<sup>40</sup>  $\rho_{A^n B^n}$  that could be shared by Alice and Bob to permutationally invariant states  $\bar{\rho}_{A^n B^n}$ .
2. Then, one applies a de Finetti theorem for permutationally invariant states, of the form

$$\bar{\rho}_{A^n B^n} \leq g_{n,x} \tau_{A^n B^n} = g_{n,x} \int d\sigma \sigma_{AB}^{\otimes n}. \quad (17)$$

In the above formula,  $\tau_{A^n B^n}$  is a particular mixture of IID states, while the  $g_{n,x}$  term is defined by the formula  $g_{n,x} = \binom{n+x-1}{x-1}$  (where  $x$  is a value that depends on the dimensions of Alice and Bob’s subsystems), and affects the final security parameters and key length in the security analysis against coherent attacks. More precisely, the above theorem is used to reduce the security of the permutationally invariant state  $\bar{\rho}_{A^n B^n}$  to the security of a *purification* of  $\tau_{A^n B^n}$ , with some costs to the security parameter and key length that depend on  $g_{n,x}$ .

3. Finally, a finite-size security proof is obtained against *all* IID states in the mixture  $\tau_{A^n B^n}$ . A particularly suitable approach for doing so is the division of all states into “filtered” and “unfiltered” states previously described in Section 4.5.1. This is then used to prove the security of the purification of  $\tau_{A^n B^n}$ .

Essentially, the proof can be viewed as “lifting” the security proof against IID collective attacks to one against coherent attacks, at the price of some penalties to the key length and security parameter.

**Remark 6.1.** *Note that in practice, rather than concluding a larger security parameter at the end of the security proof against coherent attacks, one would usually instead fix the desired final security parameter  $\varepsilon$ , and then aim to obtain an IID security proof that achieves a suitably smaller security parameter  $\varepsilon'$ , such that the final security parameter against coherent attacks is the desired value  $\varepsilon$ . This would usually come at the cost of lower key rates in the IID part of the proof, since it has to achieve a more stringent security parameter.*

When applying the postselection technique, there are several points that should be noted:

1. It is critical to ensure that the protocol indeed satisfies permutation symmetry; however, we highlight that various steps of most protocols (such as error correction and privacy amplification) are not “inherently” permutation-symmetric, which poses an obstacle in applying the postselection technique. One method to resolve this is to apply a random permutation on Alice and Bob’s raw data (see Section 3.2.3), which always yields the required permutation-symmetry property for the entire protocol, as long as the measurements are described by a channel that commutes with this random permutation.<sup>41</sup> (As a specific example, if the measurements can be described as an IID tensor product of channels, then they indeed commute with this random permutation.)
2. In the lift to security against coherent attacks, there are *two* effects — the change in the key length and the change in the security parameter, though as described above, the latter is usually compensated by further decreasing the key length. Some follow-up works based on the postselection technique only considered one of these effects, resulting in incorrect conclusions regarding the key length or security parameter.

<sup>40</sup> This is the state after the source-replacement scheme and Eve’s attack.

<sup>41</sup> A method was proposed in [93] to remove the need for this random permutation. However, it comes at the cost of a further penalty to the key length and security parameter, and some technical issues need to be addressed regarding conditioning on the accept event. It was also claimed in [94] that the random permutation is unnecessary; however, the argument contains a gap in that it focuses solely on relating the smooth min-entropy of the states with or without the random permutation. Based on the analysis in [11], this is not sufficient by itself to yield a full security proof, and so there is a logical gap that would need to be closed for this claim to be valid.

3. The lift to security against coherent attacks cannot directly be applied to optical systems, owing to their infinite dimensions resulting in an infinite cost for the lift.<sup>42</sup> Thus, a squashing map (see Section 4.6.2) must be used *before* the use of the de Finetti theorem. This poses a challenge when adding state-dependent constraints (such as those arising from the flag-state squasher) to the mixture of IID states in  $\tau_{A^n B^n}$  which is independent of the state  $\rho_{A^n B^n}$  as given by the de Finetti theorem.
4. IID security proofs for PM protocols often require Alice’s marginal state to be fixed, reflecting the trusted source preparation (see also Section 4.1). Care must be taken when lifting such a proof to security against coherent attacks with the postselection technique, as it needs a security statement against *all* states in the mixture  $\tau_{A^n B^n}$ . This is elaborated on in Section 6.3.3.

We now sketch an outline of how to perform the IID part of the security proof, followed by a discussion of a few significant works on the postselection technique.

### 6.3.1. Security proofs against IID collective attacks

The approach outlined here follows the lines of Refs. [19, 95]. The core observation for fixed-length protocols is that under the IID assumption, it is comparatively easy to study the sets of filtered and unfiltered states as described in Section 4.5.1. More precisely, the reasoning would be roughly as follows (in the following, the state always refers to the entangled Alice-Bob-Eve state arising from the source-replacement analysis):

1. Given a specific choice of acceptance test and any value  $\varepsilon_{\text{AT}}$ , and denoting the single-round state (before measurements) as  $\rho_{ABE}$ , it is possible to use IID concentration inequalities to construct a set  $S_{\varepsilon_{\text{AT}}}$  such that any  $\rho_{ABE} \notin S_{\varepsilon_{\text{AT}}}$  is a filtered state.
2. It therefore suffices to bound the smooth min-entropy for the case where the global state (before measurements) has the form  $\rho_{ABE}^{\otimes n}$  for some  $\rho_{ABE} \in S_{\varepsilon_{\text{AT}}}$ , since this would be a lower bound on the smooth min-entropy for any unfiltered state, as required from the discussion in Section 4.5.1.
3. To find such a bound, one can invoke the **asymptotic equipartition property** (AEP) [44], which lower bounds the smooth min-entropy of an IID state in terms of the von Neumann entropy of a single round, along with some “finite-size correction” terms. This reduces the task to lower bounding the von Neumann entropy produced in a single round from any state  $\rho_{ABE}$  constrained to be in the set  $S_{\varepsilon_{\text{AT}}}$ , which can be addressed using convex optimization techniques [95, 96].

As an alternative to smooth min-entropy, one could also consider the Rényi entropy as noted in Section 4.5; the overall reasoning remains essentially similar.

**Remark 6.2.** *In the above outline, the smooth min-entropy being bounded is that of the state without conditioning on the protocol accepting.<sup>43</sup> To rigorously address the issue mentioned in Section 4.5 regarding how this conditioning affects entropies, one can use [4, Lemma 10] to relate this to the smooth min-entropy of the subnormalized state conditioned on accepting, after which a suitable version of the Leftover Hashing Lemma [4, Proposition 9] can be applied.*

*We emphasize however that this requires a rigorous formulation of smooth min-entropy for subnormalized states, as described in that work (see also Ref. [3]). This involves various technical details that we will not cover within this work, but to sketch out some qualitative properties: the min-entropy (without smoothing) of a subnormalized state is defined such that it is larger than the min-entropy of its normalized version, by an amount depending on the normalization factor.<sup>44</sup> This definition is then extended to a smoothed version, and it is shown that the resulting quantity satisfies various other properties required for the security proof, such as Eq. (14).*

*For security proofs that are instead based on Rényi entropies, one can use [97, Lemma B.5] to relate the Rényi entropies of the states with and without conditioning on accepting. That lemma is slightly easier to use in that it applies to the normalized conditional state, rather than the subnormalized one; however, the lower bound it gives has an explicit dependence on the accept probability, as briefly noted in Section 4.5.2.*

<sup>42</sup> Technically, in infinite dimensions defining the integral in Eq. (17) is also a challenge. We don’t stress on this point in our description, as the infinite cost is sufficient to illustrate the problem.

<sup>43</sup> The difficulty with analyzing the state conditioned on accepting is that it may no longer be IID, hence the AEP cannot be applied.

<sup>44</sup> This is the sense in which it may be possible to find a nontrivial constant lower bound  $\kappa_{\text{const}}$  on the smooth min-entropy of *subnormalized* states conditioned on accepting, because their entropy is larger by an amount depending on the accept probability.

For variable-length protocols, a proof approach was developed in Ref. [30], though it specifically required using the Leftover Hashing Lemma based on Rényi entropy rather than smooth min-entropy. Informally, the idea was to use the IID assumption to construct a statistical estimator that can be computed from the *observed* frequency distribution in the protocol, and that lower-bounds the final Rényi entropy with high probability. This statistical estimator is then used to choose the length of the final key, in such a way that it can be shown to satisfy the variable-length security definition. However, we defer a detailed description to Ref. [30].

### 6.3.2. Christandl et al., 2008 [48]

This work introduced the idea of the postselection technique as a novel approach to security proofs against coherent attacks. However, it has a number of limitations we describe below. Note that Ref. [98] is essentially based on this approach, and thus suffers from the same limitations (in addition to some of the common gaps explained in Section 5.1). Additionally, there are a number of papers (e.g. Refs. [99, 100]) that provide IID security proofs but do not perform a full analysis against coherent attacks. Care must be taken when lifting to security against coherent attacks to avoid these issues.

The limitations are listed below:

1. The analysis is based on considering the model of the QKD protocol after source-replacement and squashing, so the protocol is modelled via a channel that acts on an entangled state between Alice and Bob (with Eve holding a purification) by first performing Alice’s source-replaced measurements and Bob’s squashed POVMs. However, the de Finetti theorem used in this work consisted of  $\tau_{A^n B^n}$  being a mixture of *all* IID states. Thus, the argument for lifting the IID security proof to one against coherent attacks implicitly required that the former proves security for *all* possible IID input states to this channel. This poses an issue regarding the following points:
  - **Source-replacement scheme:** For PM protocols, the source-replacement scheme imposes a restriction on Alice’s marginal state. The corresponding IID security proof only proves security against all IID states satisfying the restriction on Alice’s marginal state. Thus, the results from this work are not applicable to lift an IID security proof for a PM protocol to a proof against coherent attacks.
  - **Squashing:** Some squashing maps<sup>45</sup> involve additional constraints to the set of finite-dimensional IID states they prove security for.<sup>46</sup> However, such a constraint is obtained from the infinite-dimensional IID state. Thus, the postselection technique as presented in this work is not compatible with the use of these squashing maps, since the squashing must be performed prior to using the postselection theorem, otherwise the cost  $g_{n,x}$  would be infinite.
2. There was a gap in the reasoning used in the last step of their security analysis. Specifically, they claim that if Eve is given an additional  $K$  qubits of side-information about the pre-amplification string and the final key length is shortened by  $2 \log K$  bits, then the trace-distance term in the Leftover Hashing Lemma (as presented in Eq. (12)) does not increase. However, this claim does not follow directly from the Leftover Hashing Lemma, and hence the argument is incomplete.<sup>47</sup>

These issues were addressed in a follow-up work [11], though at the cost of somewhat larger penalties to the key length or security parameter, and some additional conditions to apply the proof technique. We now discuss that work in more detail.

### 6.3.3. Nahar et al., 2024 [11]

This work addressed the limitations described above as follows.

1. As mentioned in Section 6.3.2, the analysis is based on the protocol modelled as a channel that acts on an entangled state between Alice and Bob that is a result of the source-replacement scheme and squashing. The challenges that arise for these cases were dealt with as follows:

<sup>45</sup> See Table I for more details on the different squashing maps, and their compatibility with the postselection technique

<sup>46</sup> As an example, the proof might use the fact that most of the state is in the single-photon subspace.

<sup>47</sup> It is true that the *upper bound* in Eq. (12) of the Leftover Hashing Lemma is nonincreasing under these changes, but this is a distinct statement from the claim that the trace-distance term itself is nonincreasing.

- **Source-replacement scheme:** The challenge here was that the source-replacement scheme required Alice to have a fixed marginal state (which was used in the security proof against IID attacks), and needs to be accounted for in the mixture of IID states  $\tau_{A^n B^n}$ . This was addressed through the usage of a modified de Finetti theorem [101, Corolary 3.2] which allowed the mixture to be over all IID states that had the same marginal as  $\rho_{A^n B^n}$ .<sup>48</sup> Also, this work improved on the cost  $g_{n,x}$  in the de Finetti theorem stated in Ref. [101].
  - **Squashing:** Here, the challenge was that more generally applicable squashers (flag-state squasher and dimension reduction method) required additional constraints to be applied to the finite-dimensional IID states. This was addressed through the construction of a new squashing map that was just as generally applicable as the flag-state squasher<sup>49</sup>, yet did not require any additional constraints. Thus, this squashing map can be used before the de Finetti theorem is applied.
2. For fixed-length protocols, this work showed that if the IID security proof proceeds *specifically* by bounding the smooth min-entropy of all unfiltered states (satisfying Alice’s reduced-state constraint) as described in Section 4.5.1, then it can be validly lifted to a security proof against coherent attacks, though with larger effects on the security parameter as compared to the initial claim in Ref. [48]. More generally, for either fixed-length or variable-length protocols, this work showed that such a lift is possible even without that condition, but the effect on the security parameter is slightly larger.

In addition to addressing these limitations, this work also derived some improvements to the finite-size terms appearing in the de Finetti theorem, reducing the impact of those terms on the finite-size key rates. Note that although this work describes a lift for decoy-state protocols, it still requires a finite-size, IID security proof for decoy-state protocols. Although we do not believe this to be significantly different from other IID security proofs, we do not know of any currently published self-contained decoy-state security proof.

#### 6.4. Entropy accumulation based proofs

There are a variety of accumulation theorems, such as the entropy accumulation theorem (EAT) [97, 102], generalized entropy accumulation theorem (GEAT) [46, 103] and generalized Rényi entropy accumulation theorem (GREAT) [103], which we discuss in greater detail below. Currently, most of these results are focused on fixed-length protocols. Any of these theorems can be utilized for QKD security proofs, as long as the QKD protocol can be abstractly represented as a sequential process satisfying the conditions of the relevant theorem. An example of such a sequential process can be seen in Fig. 3. However, in general one needs to be careful to verify that a sequential process indeed correctly represents a QKD protocol and satisfies the assumptions of the desired accumulation theorem.

Abstractly, entropy accumulation theorems obtain a lower bound on the  $n$ -round entropy (smooth-min and/or Rényi) of a sequential process in terms of a single-round quantity of the form<sup>50</sup>

$$H_{\min}^{\bar{\epsilon}}(\mathbf{S}|\mathbf{E})_{\Omega_{\text{acc}}} \geq nh - \text{corrections}, \quad (18)$$

where  $\mathbf{S}$  are the secret registers containing the pre-amplification string and  $\mathbf{E}$  is all of Eve’s side information except the communication for error correction, error verification and the choice of the hash function for privacy amplification.

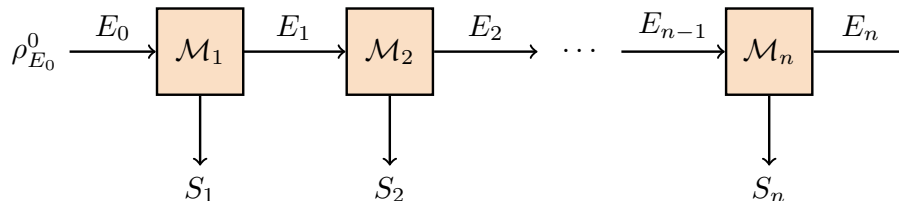

FIG. 3: An example of a sequential process representable in the GEAT. Here  $S_i$  can represent the secret registers containing the pre-amplification string, and  $E_i$  is Eve’s side-information of round  $i$ . The figure was adapted from Ref. [46].

<sup>48</sup> Note that for this to hold,  $\rho_{A^n}$  must also be IID. This is equivalent to assuming that Alice’s prepares random states in an IID fashion.

<sup>49</sup> In particular, these squashing maps are applicable to all DV protocols, but not to CV protocols.

<sup>50</sup> The correction term here depends on the probability of the event  $\Omega_{\text{acc}}$ .

Here  $n$  is the total number of rounds in the QKD protocol, and  $h$  is a single-round quantity that typically depends on a construction called the min-tradeoff function, which we will discuss in more detail below. In particular,  $h$  is found by minimizing the min-tradeoff function over the acceptance set.

Furthermore, as described in Section 4.5, having a valid lower bound on the entropy of the state conditioned on the protocol accepting is the essential ingredient for a security proof. The EAT, GEAT and GREAT provide powerful tools to achieve such lower bounds. Additionally, they do not require a security proof against IID attacks; they enable one to directly bound the entropy, comparable to the entropic uncertainty relation (Section 6.1).

#### 6.4.1. Dupuis et al., 2020 [97]

This work proves the first version of the EAT for a sequential process (generating the pre-amplification string) that satisfies a technical requirement called the Markov condition. The Markov condition restricts the theorem to protocols that make only “weakly dependent announcements” [104] and limits it to being applied mainly to entanglement-based protocols. A weakly dependent announcement requires, for example, that a detection event depends only on the total photon number, but not the state. All of the results based on the original EAT perform the reduction to a single-round quantity by calculating the so-called min-tradeoff function, which is an affine lower bound on the key rate in terms of announcements in the test rounds, e.g. the error rate in the  $X$ -basis. In Ref. [104], a numerical framework for constructing min-tradeoff functions of entanglement-based protocols in the EAT-framework was presented, and then used to compute key rates for entanglement-based protocols.

However, the main drawback of the EAT is that it cannot be directly applied to prepare-and-measure protocols. This drawback could in principle be addressed using a “virtual state tomography” technique developed in Ref. [105], but thus far this technique has not been applied to decoy-state BB84 specifically, and the resulting performance is uncertain.

#### 6.4.2. Metger et al., 2022 [46], Metger et al., 2023 [106]

Ref. [46] extended the above result to a *generalized* entropy accumulation theorem (GEAT), which considers sequential processes satisfying a different technical requirement called the non-signalling condition (instead of the Markov condition). This allowed it to be applied to prepare-and-measure protocols; however, only under a specific restriction. Namely, it requires that one must assume that while Eve can jointly attack all signals, she only interacts with one signal at a time, i.e. applies the attack in sequence. We shall refer to this assumption as the “sequential assumption”. Satisfying this assumption in practical implementations imposes strong limits on the repetition rate at which the protocol can be run. Ref. [106] uses the GEAT to compute key rates for the B92 protocol, and describes the application of the GEAT to decoy-state calculations, without performing explicit calculations.

Note that in general, the task of numerically finding the min-tradeoff function with the best finite-size performance can be very difficult. Thus, most works so far have focused on applying EAT- or GEAT-based security proofs to simple device-independent QKD protocols or qubit protocols, with Ref. [31] described below being the only work using it to explicitly compute key rates for decoy-state protocols. Ref. [103] improves the GEAT by obtaining tighter finite-size key rates, and avoiding explicit min-tradeoff function calculations. This leads to a significantly simpler framework, but it has not been applied to decoy-state protocols yet.

#### 6.4.3. Kamin, Arqand et al. 2024 [31]

This work applies the GEAT [46, 106] to the qubit BB84 and decoy-state BB84 protocols. While the usage of the GEAT requires the sequential assumption discussed above, this requirement can be removed with the results in Refs. [107, 108] (or Ref. [109], currently in preparation). Furthermore, its security proof only applies to fixed-length protocols.

One technical contribution of this work was that it developed several techniques to optimize the finite-size performance of the GEAT, for instance by optimizing the choice of the min-tradeoff function using techniques somewhat similar to Ref. [104]. Moreover, a tighter formulation for decoy-state protocols is derived, which even in the asymptotic regime should result in higher key rates than the approaches in Ref. [110]. Finally, in Ref. [31, App. B] it was shown that one can incorporate the flag-state squasher with the GEAT analysis, which is especially relevant for optical detection setups.



## Acknowledgments

This article was written as part of the Qu-Gov project, which was commissioned by the German Federal Ministry of Finance. We thank the Bundesdruckerei — Innovation Leadership and Team for their support and encouragement.

The writing of this document greatly benefited from interactions with the wider community, which includes numerous insights, discussions, and feedback, over many years. However, any errors or omissions are entirely our own responsibility. We would like to thank Takaya Matsuura for teaching the details of the phase error correction proof approach. We would like to thank Masato Koashi for further explaining the applications of the phase error correction proof approach, and the source-replacement scheme as applied to this proof technique. We thank Fred Fung for explaining the universal squasher to us. We thank Toyohiro Tsurumaru, Victor Zapatero, Margarida Pereira and Guillermo Currás-Lorenzo for helpful discussions about the EUR and phase error correction techniques, and the similarities between them. We also thank Ian George, Jie Lin and Peter Brown for helpful discussions on the EAT and its improved versions.

- 
- [1] ANSSI, AIVD, BSI, and Swedish Armed Forces, Position Paper on Quantum Key Distribution, [https://www.bsi.bund.de/SharedDocs/Downloads/EN/BSI/Crypto/Quantum\\_Positionspapier.html](https://www.bsi.bund.de/SharedDocs/Downloads/EN/BSI/Crypto/Quantum_Positionspapier.html) (2024).
  - [2] M. A. Nielsen and I. L. Chuang, *Quantum Computation and Quantum Information* (Cambridge University Press, New York, 2010).
  - [3] M. Tomamichel, *Quantum Information Processing with Finite Resources*, SpringerBriefs in Mathematical Physics, Vol. 5 (Springer International Publishing, Cham, 2016).
  - [4] M. Tomamichel and A. Leverrier, A largely self-contained and complete security proof for quantum key distribution, *Quantum* **1**, 14 (2017).
  - [5] M. Sandfuchs, C. Ferradini, and R. Renner, Companion work describing the security framework of QKD, in preparation.
  - [6] C. Portmann and R. Renner, Security in quantum cryptography, *Reviews of Modern Physics* **94**, 025008 (2022).
  - [7] M. N. Wegman and J. L. Carter, New hash functions and their use in authentication and set equality, *Journal of Computer and System Sciences* **22**, 265 (1981).
  - [8] C. Portmann, Key Recycling in Authentication, *IEEE Transactions on Information Theory* **60**, 4383 (2014).
  - [9] E. Y.-Z. Tan, P. Sekatski, J.-D. Bancal, R. Schwonnek, R. Renner, N. Sangouard, and C. C.-W. Lim, Improved DIQKD protocols with finite-size analysis, *Quantum* **6**, 880 (2022).
  - [10] R. Arnon-Friedman, R. Renner, and T. Vidick, Simple and Tight Device-Independent Security Proofs, *SIAM Journal on Computing* **48**, 181 (2019).
  - [11] S. Nahar, D. Tupkary, Y. Zhao, N. Lütkenhaus, and E. Y.-Z. Tan, Postselection Technique for Optical Quantum Key Distribution with Improved de Finetti Reductions, *PRX Quantum* **5**, 040315 (2024).
  - [12] B. Kraus, N. Gisin, and R. Renner, Lower and Upper Bounds on the Secret-Key Rate for Quantum Key Distribution Protocols Using One-Way Classical Communication, *Physical Review Letters* **95**, 080501 (2005).
  - [13] R. Renner, N. Gisin, and B. Kraus, Information-theoretic security proof for quantum-key-distribution protocols, *Physical Review A* **72**, 012332 (2005).
  - [14] J. M. Renes and G. Smith, Noisy Processing and Distillation of Private Quantum States, *Physical Review Letters* **98**, 020502 (2007).
  - [15] U. Maurer, Secret key agreement by public discussion from common information, *IEEE Transactions on Information Theory* **39**, 733 (1993).
  - [16] S. Wolf, *Information-Theoretically and Computationally Secure Key Agreement in Cryptography*, *Doctoral Thesis*, ETH Zurich (1999).
  - [17] H. F. Chau, Practical scheme to share a secret key through a quantum channel with a 27.6% bit error rate, *Physical Review A* **66**, 060302 (2002).
  - [18] D. Gottesman and H.-K. Lo, Proof of security of quantum key distribution with two-way classical communications, *IEEE Transactions on Information Theory* **49**, 457 (2003).
  - [19] R. Renner, *Security of Quantum Key Distribution*, *Doctoral Thesis*, ETH Zurich (2005).
  - [20] J. Bae and A. Acín, Key distillation from quantum channels using two-way communication protocols, *Physical Review A* **75**, 012334 (2007).
  - [21] G. Brassard and L. Salvail, Secret-key reconciliation by public discussion, *Lecture Notes in Computer Science (including subseries Lecture Notes in Artificial Intelligence and Lecture Notes in Bioinformatics)* **765 LNCS**, 410 (1994).
  - [22] C. H. Bennett, G. Brassard, and N. D. Mermin, Quantum cryptography without Bell's theorem, *Physical Review Letters* **68**, 557 (1992).
  - [23] M. Curty, M. Lewenstein, and N. Lütkenhaus, Entanglement as a Precondition for Secure Quantum Key Distribution, *Physical Review Letters* **92**, 217903 (2004).
  - [24] K. Horodecki, M. Horodecki, P. Horodecki, and J. Oppenheim, General Paradigm for Distilling Classical Key From Quantum States, *IEEE Transactions on Information Theory* **55**, 1898 (2009).
  - [25] D. R. Stinson, Universal hashing and authentication codes, *Designs, Codes and Cryptography* **4**, 369 (1994).
  - [26] Y. Mansour, N. Nisan, and P. Tiwari, The computational complexity of universal hashing, *Theoretical Computer Science*



- 107**, 121 (1993).
- [27] E. O. Kiktenko, A. O. Malyshev, M. A. Gavreev, A. A. Bozhedarov, N. O. Pozhar, M. N. Anufriev, and A. K. Fedorov, Lightweight Authentication for Quantum Key Distribution, *IEEE Transactions on Information Theory* **66**, 6354 (2020).
- [28] F. Dupuis, Privacy Amplification and Decoupling Without Smoothing, *IEEE Transactions on Information Theory* **69**, 7784 (2023).
- [29] A. De, C. Portmann, T. Vidick, and R. Renner, Trevisan’s Extractor in the Presence of Quantum Side Information, *SIAM Journal on Computing* **41**, 915 (2012).
- [30] D. Tupkary, E. Y.-Z. Tan, and N. Lütkenhaus, Security proof for variable-length quantum key distribution, *Physical Review Research* **6**, 023002 (2024).
- [31] L. Kamin, A. Arqand, I. George, N. Lütkenhaus, and E. Y.-Z. Tan, Finite-size analysis of prepare-and-measure and decoy-state QKD via entropy accumulation (2024), [arXiv:2406.10198](https://arxiv.org/abs/2406.10198).
- [32] S. Nahar, T. Upadhyaya, and N. Lütkenhaus, Imperfect phase randomization and generalized decoy-state quantum key distribution, *Physical Review Applied* **20**, 064031 (2023).
- [33] N. J. Beaudry, T. Moroder, and N. Lütkenhaus, Squashing Models for Optical Measurements in Quantum Communication, *Physical Review Letters* **101**, 093601 (2008).
- [34] T. Tsurumaru and K. Tamaki, Security proof for quantum-key-distribution systems with threshold detectors, *Physical Review A* **78**, 032302 (2008).
- [35] T. Tsurumaru, Squash operator and symmetry, *Physical Review A* **81**, 012328 (2010).
- [36] C.-H. F. Fung, H. F. Chau, and H.-K. Lo, Universal squash model for optical communications using linear optics and threshold detectors, *Physical Review A* **84**, 020303 (2011).
- [37] O. Gittsovich, N. J. Beaudry, V. Narasimhachar, R. R. Alvarez, T. Moroder, and N. Lütkenhaus, Squashing model for detectors and applications to quantum-key-distribution protocols, *Physical Review A* **89**, 012325 (2014).
- [38] Y. Zhang, P. J. Coles, A. Winick, J. Lin, and N. Lütkenhaus, Security proof of practical quantum key distribution with detection-efficiency mismatch, *Physical Review Research* **3**, 013076 (2021).
- [39] T. Upadhyaya, T. Van Himbeeck, J. Lin, and N. Lütkenhaus, Dimension Reduction in Quantum Key Distribution for Continuous- and Discrete-Variable Protocols, *PRX Quantum* **2**, 020325 (2021).
- [40] D. Gottesman, H.-K. Lo, N. Lütkenhaus, and J. Preskill, Security of quantum key distribution with imperfect devices (2004), [arXiv:quant-ph/0212066](https://arxiv.org/abs/quant-ph/0212066).
- [41] I. W. Primaatmaja, W. Y. Kon, and C. Lim, Discrete-modulated continuous-variable quantum key distribution secure against general attacks (2024), [arXiv:2409.02630](https://arxiv.org/abs/2409.02630).
- [42] J.-P. Bourgoin, N. Gigov, B. L. Higgins, Z. Yan, E. Meyer-Scott, A. K. Khandani, N. Lütkenhaus, and T. Jennewein, Experimental quantum key distribution with simulated ground-to-satellite photon losses and processing limitations, *Physical Review A* **92**, 052339 (2015).
- [43] Z. Zhang, Q. Zhao, M. Razavi, and X. Ma, Improved key-rate bounds for practical decoy-state quantum-key-distribution systems, *Physical Review A* **95**, 012333 (2017).
- [44] M. Tomamichel, R. Colbeck, and R. Renner, A Fully Quantum Asymptotic Equipartition Property, *IEEE Transactions on Information Theory* **55**, 5840 (2009).
- [45] C. Pfister, N. Lütkenhaus, S. Wehner, and P. J. Coles, Sifting attacks in finite-size quantum key distribution, *New Journal of Physics* **18**, 053001 (2016), [arXiv:1506.07502 \[quant-ph\]](https://arxiv.org/abs/1506.07502).
- [46] T. Metger, O. Fawzi, D. Sutter, and R. Renner, Generalised entropy accumulation, in *2022 IEEE 63rd Annual Symposium on Foundations of Computer Science (FOCS)* (2022) pp. 844–850.
- [47] K. Tamaki, H.-K. Lo, A. Mizutani, G. Kato, C. C. W. Lim, K. Azuma, and M. Curty, Security of quantum key distribution with iterative sifting, *Quantum Science and Technology* **3**, 014002 (2018), [arXiv:1610.06499 \[quant-ph\]](https://arxiv.org/abs/1610.06499).
- [48] M. Christandl, R. König, and R. Renner, Postselection Technique for Quantum Channels with Applications to Quantum Cryptography, *Physical Review Letters* **102**, 020504 (2009).
- [49] W. Hoeffding, Probability Inequalities for Sums of Bounded Random Variables, *Journal of the American Statistical Association* **58**, 13 (1963).
- [50] R. J. Serfling, Probability Inequalities for the Sum in Sampling without Replacement, *The Annals of Statistics* **2**, 39 (1974).
- [51] G. Kato, Concentration inequality using unconfirmed knowledge (2020), [arXiv:2002.04357 \[math.PR\]](https://arxiv.org/abs/2002.04357).
- [52] K. Azuma, Weighted sums of certain dependent random variables, *Tohoku Mathematical Journal* **19**, 357 (1967).
- [53] W. T. Buttler, S. K. Lamoreaux, J. R. Torgerson, G. H. Nickel, C. H. Donahue, and C. G. Peterson, Fast, efficient error reconciliation for quantum cryptography (2003), [arXiv:quant-ph/0203096](https://arxiv.org/abs/quant-ph/0203096).
- [54] D. Tupkary and N. Lütkenhaus, Using Cascade in quantum key distribution, *Physical Review Applied* **20**, 064040 (2023).
- [55] K. Tamaki and G. Kato, Quantum circuit for the proof of the security of quantum key distribution without encryption of error syndrome and noisy processing, *Physical Review A* **81**, 022316 (2010).
- [56] Z. Du, G. Liu, and X. Ma, Advantage Distillation for Quantum Key Distribution (2024), [arXiv:2404.14733 \[quant-ph\]](https://arxiv.org/abs/2404.14733).
- [57] G. Currás-Lorenzo, Á. Navarrete, K. Azuma, G. Kato, M. Curty, and M. Razavi, Tight finite-key security for twin-field quantum key distribution, *npj Quantum Information* **7**, 1 (2021).
- [58] D. Tupkary, S. Nahar, P. Sinha, and N. Lütkenhaus, Phase error rate estimation with basis-efficiency mismatch for decoy-state BB84 (2024), [arXiv:2408.17349 \[quant-ph\]](https://arxiv.org/abs/2408.17349).
- [59] S. Kawakami, *Security of Quantum Key Distribution with Weak Coherent Pulses*, Ph.D. thesis.
- [60] M. Hayashi and T. Tsurumaru, Concise and tight security analysis of the Bennett–Brassard 1984 protocol with finite key

- lengths, *New Journal of Physics* **14**, 093014 (2012).
- [61] M. Tomamichel and R. Renner, Uncertainty Relation for Smooth Entropies, *Physical Review Letters* **106**, 110506 (2011).
- [62] M. Koashi, Efficient quantum key distribution with practical sources and detectors (2006), [arXiv:quant-ph/0609180](https://arxiv.org/abs/quant-ph/0609180).
- [63] J. Wiesemann, J. Krause, D. Tupkary, N. Lütkenhaus, D. Rusca, and N. Walenta, [A consolidated and accessible security proof for finite-size decoy-state quantum key distribution](https://arxiv.org/abs/2405.16578) (2024), [arXiv:2405.16578](https://arxiv.org/abs/2405.16578) [quant-ph].
- [64] C. C. W. Lim, M. Curty, N. Walenta, F. Xu, and H. Zbinden, Concise security bounds for practical decoy-state quantum key distribution, *Physical Review A* **89**, 022307 (2014).
- [65] D. Rusca, A. Boaron, F. Grönenfelder, A. Martin, and H. Zbinden, [Finite-key analysis on the 1-decoy state QKD protocol](https://arxiv.org/abs/1801.03443) (2018), [arXiv:1801.03443](https://arxiv.org/abs/1801.03443) [quant-ph].
- [66] G. Guarda, D. Ribezzo, D. Salvoni, C. Bruscino, P. Ercolano, M. Ejrnaes, L. Parlato, C. Zhang, H. Li, L. You, I. Vagniluca, C. De Lazzari, T. Occhipinti, G. P. Pepe, A. Zavatta, and D. Bacco, BB84 decoy-state QKD protocol over long-distance optical fiber, in *2023 23rd International Conference on Transparent Optical Networks (ICTON)* (2023) pp. 1–4.
- [67] X. Li, H.-W. Yuan, C.-M. Zhang, and Q. Wang, One-decoy state reference-frame-independent quantum key distribution\*, *Chinese Physics B* **29**, 070303 (2020).
- [68] A. Boaron, G. Boso, D. Rusca, C. Vulliez, C. Autebert, M. Caloz, M. Perrenoud, G. Gras, F. Bussi eres, M.-J. Li, D. Nolan, A. Martin, and H. Zbinden, [Secure quantum key distribution over 421 km of optical fiber](https://arxiv.org/abs/1807.03222) (2018), [arXiv:1807.03222](https://arxiv.org/abs/1807.03222).
- [69] T. Attema, J. Bosman, and N. Neumann, Optimizing the Decoy-State BB84 QKD Protocol Parameters (2020), [arXiv:2006.15962](https://arxiv.org/abs/2006.15962).
- [70] H. F. Chau, Decoy-state quantum key distribution with more than three types of photon intensity pulses, *Physical Review A* **97**, 040301 (2018).
- [71] H. F. Chau and K. C. J. Ng, Application of an improved version of McDiarmid inequality in finite-key-length decoy-state quantum key distribution, *New Journal of Physics* **22**, 023011 (2020).
- [72] Y. Wang, W.-S. Bao, C. Zhou, M.-S. Jiang, and H.-W. Li, Tight finite-key analysis of a practical decoy-state quantum key distribution with unstable sources, *Physical Review A* **94**, 032335 (2016).
- [73] C. Zhou, Y. Zhou, Y. Xu, Y. Wang, Y. Lu, M. Jiang, X. Zhang, and W. Bao, Finite-Key Analysis of 1-Decoy Method Quantum Key Distribution with Intensity Fluctuation, *Applied Sciences* **12**, 4709 (2022).
- [74] G. Foletto, F. Picciariello, C. Agnesi, P. Villoresi, and G. Vallone, Security bounds for decoy-state quantum key distribution with arbitrary photon-number statistics, *Physical Review A* **105**, 012603 (2022).
- [75] C. Zhou, W.-S. Bao, H.-W. Li, Y. Wang, Y. Li, Z.-Q. Yin, W. Chen, and Z.-F. Han, Tight finite-key analysis for passive decoy-state quantum key distribution under general attacks, *Physical Review A* **89**, 052328 (2014).
- [76] M. Lucamarini, J. F. Dynes, B. Fröhlich, Z. Yuan, and A. J. Shields, Security Bounds for Efficient Decoy-State Quantum Key Distribution, *IEEE Journal of Selected Topics in Quantum Electronics* **21**, 197 (2015).
- [77] W. Wang, K. Tamaki, and M. Curty, [Finite-key security analysis for quantum key distribution with leaky sources](https://arxiv.org/abs/1803.09508) (2018), [arXiv:1803.09508](https://arxiv.org/abs/1803.09508).
- [78]  . Navarrete and M. Curty, [Improved Finite-Key Security Analysis of Quantum Key Distribution Against Trojan-Horse Attacks](https://arxiv.org/abs/2202.06630) (2022), [arXiv:2202.06630](https://arxiv.org/abs/2202.06630).
- [79] J. S. Sidhu, T. Brougham, D. McArthur, R. G. Pousa, and D. K. L. Oi, Finite key effects in satellite quantum key distribution, *npj Quantum Information* **8**, 1 (2022).
- [80] C.-H. F. Fung, X. Ma, and H. F. Chau, Practical issues in quantum-key-distribution postprocessing, *Physical Review A* **81**, 012318 (2010).
- [81] M. Pereira, G. Curr as-Lorenzo,  . Navarrete, A. Mizutani, G. Kato, M. Curty, and K. Tamaki, Modified BB84 quantum key distribution protocol robust to source imperfections, *Physical Review Research* **5**, 023065 (2023).
- [82] K. Tamaki, M. Curty, G. Kato, H.-K. Lo, and K. Azuma, Loss-tolerant quantum cryptography with imperfect sources, *Physical Review A* **90**, 052314 (2014).
- [83] G. Curr as-Lorenzo, M. Pereira, G. Kato, M. Curty, and K. Tamaki, [A security framework for quantum key distribution implementations](https://arxiv.org/abs/2305.05930) (2024), [arXiv:2305.05930](https://arxiv.org/abs/2305.05930).
- [84] V. Zapatero, Ivaro Navarrete, and M. Curty, [Implementation security in quantum key distribution](https://arxiv.org/abs/2310.20377) (2023), [arXiv:2310.20377](https://arxiv.org/abs/2310.20377) [quant-ph].
- [85] M. Koashi, [Simple security proof of quantum key distribution via uncertainty principle](https://arxiv.org/abs/quant-ph/0505108) (2005), [arXiv:quant-ph/0505108](https://arxiv.org/abs/quant-ph/0505108).
- [86] M. Koashi, Simple security proof of quantum key distribution based on complementarity, *New Journal of Physics* **11**, 045018 (2009).
- [87] P. W. Shor and J. Preskill, Simple Proof of Security of the BB84 Quantum Key Distribution Protocol, *Physical Review Letters* **85**, 441 (2000).
- [88] M. Hayashi and R. Nakayama, Security analysis of the decoy method with the Bennett–Brassard 1984 protocol for finite key lengths, *New Journal of Physics* **16**, 063009 (2014).
- [89] T. Tsurumaru and M. Hayashi, [Dual universality of hash functions and its applications to quantum cryptography](https://arxiv.org/abs/1101.0064) (2012), [arXiv:1101.0064](https://arxiv.org/abs/1101.0064).
- [90] A. Mizutani, M. Curty, C. C. W. Lim, N. Imoto, and K. Tamaki, Finite-key security analysis of quantum key distribution with imperfect light sources, *New Journal of Physics* **17**, 093011 (2015).
- [91] A. Mizutani, G. Kato, K. Azuma, M. Curty, R. Ikuta, T. Yamamoto, N. Imoto, H.-K. Lo, and K. Tamaki, Quantum key distribution with setting-choice-independently correlated light sources, *npj Quantum Information* **5**, 10.1038/s41534-018-0122-y (2019).
- [92] T. Tsurumaru, Leftover Hashing From Quantum Error Correction: Unifying the Two Approaches to the Security Proof of

- Quantum Key Distribution, *IEEE Transactions on Information Theory* **66**, 3465 (2020).
- [93] N. J. Beaudry, *Assumptions in Quantum Cryptography* (2015), [arXiv:1505.02792 \[quant-ph\]](#).
  - [94] V. Scarani and R. Renner, Security Bounds for Quantum Cryptography with Finite Resources, in *Theory of Quantum Computation, Communication, and Cryptography*, edited by Y. Kawano and M. Mosca (Springer, Berlin, Heidelberg, 2008) pp. 83–95.
  - [95] I. George, J. Lin, and N. Lütkenhaus, Numerical calculations of the finite key rate for general quantum key distribution protocols, *Physical Review Research* **3**, 013274 (2021).
  - [96] A. Winick, N. Lütkenhaus, and P. J. Coles, Reliable numerical key rates for quantum key distribution, *Quantum* **2**, 77 (2018).
  - [97] F. Dupuis, O. Fawzi, and R. Renner, Entropy Accumulation, *Communications in Mathematical Physics* **379**, 867 (2020).
  - [98] D. Bunandar, L. C. Góvia, H. Krovi, and D. Englund, Numerical finite-key analysis of quantum key distribution, *npj Quantum Information* **6**, 104 (2020).
  - [99] M. Lucamarini, K. Patel, J. Dynes, B. Fröhlich, A. Sharpe, A. Dixon, Z. Yuan, R. Penty, and A. Shields, Efficient decoy-state quantum key distribution with quantified security, *Optics express* **21**, 24550 (2013).
  - [100] D. Rusca, A. Boaron, M. Curty, A. Martin, and H. Zbinden, Security proof for a simplified Bennett-Brassard 1984 quantum-key-distribution protocol, *Physical Review A* **98**, 052336 (2018).
  - [101] O. Fawzi and R. Renner, Quantum Conditional Mutual Information and Approximate Markov Chains, *Communications in Mathematical Physics* **340**, 575 (2015).
  - [102] F. Dupuis and O. Fawzi, Entropy Accumulation With Improved Second-Order Term, *IEEE Transactions on Information Theory* **65**, 7596 (2019).
  - [103] A. Arqand, T. A. Hahn, and E. Y.-Z. Tan, *Generalized Rényi entropy accumulation theorem and generalized quantum probability estimation* (2024), [arXiv:2405.05912 \[quant-ph\]](#).
  - [104] I. George, J. Lin, T. van Himbeek, K. Fang, and N. Lütkenhaus, *Finite-Key Analysis of Quantum Key Distribution with Characterized Devices Using Entropy Accumulation* (2022), [arXiv:2203.06554 \[quant-ph\]](#).
  - [105] S. Bäuml, C. Pascual-García, V. Wright, O. Fawzi, and A. Acín, Security of discrete-modulated continuous-variable quantum key distribution, *Quantum* **8**, 1418 (2024).
  - [106] T. Metger and R. Renner, Security of quantum key distribution from generalised entropy accumulation, *Nature Communications* **14**, 5272 (2023).
  - [107] A. Arqand and E. Y. Z. Tan, *Marginal-constrained entropy accumulation theorem* (2025), [arXiv:2502.02563 \[quant-ph\]](#).
  - [108] O. Fawzi, J. Kochanowski, C. Rouz, and T. V. Himbeek, *Additivity and chain rules for quantum entropies via multi-index Schatten norms* (2025), [arXiv:2502.01611 \[quant-ph\]](#).
  - [109] T. van Himbeek and P. Brown, Tight and general finite-size security of quantum key distribution (2024), in preparation, presented at QCrypt 2023.
  - [110] L. Kamin, D. Tupkary, and N. Lütkenhaus, *Improved finite-size effects in QKD protocols with applications to decoy-state QKD* (2025), [arXiv:2502.05382 \[quant-ph\]](#).