

Secure Semantic Communication With Homomorphic Encryption

Rui Meng, Dayu Fan, Haixiao Gao, Yifan Yuan, Bizhu Wang, Xiaodong Xu, *Senior Member, IEEE*, Mengying Sun, Chen Dong, Xiaofeng Tao, *Senior Member, IEEE*, Ping Zhang, *Fellow, IEEE*, and Dusit Niyato, *Fellow, IEEE*

Abstract—In recent years, Semantic Communication (SemCom), which aims to achieve efficient and reliable transmission of meaning between agents, has garnered significant attention from both academia and industry. To ensure the security of communication systems, encryption techniques are employed to safeguard confidentiality and integrity. However, traditional cryptography-based encryption algorithms encounter obstacles when applied to SemCom. Motivated by this, this paper explores the feasibility of applying homomorphic encryption to SemCom. Initially, we review the encryption algorithms utilized in mobile communication systems and analyze the challenges associated with their application to SemCom. Subsequently, we employ scale-invariant feature transform to demonstrate that semantic features can be preserved in homomorphic encrypted ciphertext. Based on this finding, we propose a task-oriented SemCom scheme secured through homomorphic encryption. We design the privacy preserved deep joint source-channel coding (JSCC) encoder and decoder, and the frequency of key updates can be adjusted according to service requirements without compromising transmission performance. Simulation results validate that, when compared to plaintext images, the proposed scheme can achieve almost the same classification accuracy performance when dealing with homomorphic ciphertext images. Furthermore, we provide potential future research directions for homomorphic encrypted SemCom.

Index Terms—Semantic communication, 6G, homomorphic encryption, data security.

I. INTRODUCTION

The 5th generation mobile communication (5G) has been globally commercialized on a large scale, facilitating digitalization, automation, and intelligence across various sectors, including intelligent manufacturing, smart healthcare, intelligent transportation, and smart homes. According to a research report released by the TD Industry Alliance, by the first quarter of 2024, the total number of global 5G users was about 1.68

billion. To further support emerging services like holographic communication, digital twinning, and intelligent sensing, the research on 6G is in full swing in academia and industry [1].

The profound integration of communications and Artificial Intelligence (AI) is a notable trend in the advancement of mobile communication systems. The powerful capabilities of AI in data processing and analysis, coupled with its continuous learning and optimization abilities, help reduce network operational costs while simultaneously enhancing network performance. International Telecommunication Union (ITU) characterizes AI and communication as one of six usage scenarios for 6G, and highlights ubiquitous intelligence as one of four design principles. In contrast to the peripheral and patch-like AI applications of 5G, 6G embeds endogenous intelligence as a foundational design principle from inception, marking a substantial shift from “external” to “endogenous” integration [2].

As a quintessential technology for the integration of communications and AI, Semantic Communication (SemCom) initially extracts, compresses, and transmits the selective features of the original signal, and subsequently employs semantic information to facilitate effective communication. This innovative “comprehend before transmitting” paradigm allows both communicating parties to transmit information based on their needs, effectively eliminating redundant elements. Consequently, this approach leads to a substantial decrease in the volume of information transmitted and a notable reduction in energy consumption [3].

As an emerging technology, SemCom faces significant security challenges in terms of confidentiality, integrity, and availability [4]. 1) Confidentiality: The privacy data within knowledge bases (KBs) is vulnerable to brute-force and spoofing attacks. If attackers gain unauthorized access, they can execute poisoning or backdoor attacks to alter KBs, leading to breaches of confidentiality [5]. Additionally, semantic eavesdropping attacks pose a significant threat by intercepting transmitted signals and leveraging generative AI models capable of powerful semantic reasoning and interpretation to infer semantic information [6]. 2) Integrity: Agents may collect environmental semantic data through sensors, and attackers could compromise SemCom’s integrity by injecting false data into private KBs [4]. 3) Availability: Hackers might dispatch semantic interference streams to degrade the consistency and quality of the semantic content within transmitted data. This degradation can hinder the receiver’s ability to accurately comprehend the intended messages, thereby undermining the availability of SemCom [7].

Corresponding author: Xiaodong Xu.

Rui Meng, Dayu Fan, Haixiao Gao, Yifan Yuan, Bizhu Wang, Mengying Sun, Chen Dong, and Ping Zhang are with the State Key Laboratory of Networking and Switching Technology, Beijing University of Posts and Telecommunications, Beijing 100876, China (e-mail: buptmengrui@bupt.edu.cn; fandayu@bupt.edu.cn; haixiao@bupt.edu.cn; yifanyuan@bupt.edu.cn; wangbizhu_7@bupt.edu.cn; smy_bupt@bupt.edu.cn; dongchen@bupt.edu.cn; pzhang@bupt.edu.cn).

Xiaodong Xu is with the State Key Laboratory of Networking and Switching Technology, Beijing University of Posts and Telecommunications, Beijing 100876, China, and also with the Department of Broad-band Communication, Peng Cheng Laboratory, Shenzhen 518066, Guangdong, China (e-mail: xuxiaodong@bupt.edu.cn).

Xiaofeng Tao is with the National Engineering Laboratory for Mobile Network Technologies, Beijing University of Posts and Telecommunications, Beijing 100876, China (email: taofx@bupt.edu.cn).

Dusit Niyato is with Nanyang Technological University, Singapore (email: dniyato@ntu.edu.sg).

TABLE I: The evolution of encryption algorithms of mobile communication systems

Syst.	Encryption Algorithm	Description
1G	Not encrypted	1G primarily employs analog technology. Voices are transmitted through unencrypted radio waves with a transmission rate of approximately 2.4 Kbps.
2G	A5	1. Four versions are developed, namely A5/1, A5/2, A5/3, and A5/4. 2. The shift registers are too short, making them susceptible to exhaustive attacks. In the evolution of communication systems, its security is continually being challenged.
3G	KASUMI, SNOW 3G ¹	1. The KASUMI algorithm is a block cipher incorporating security measures against differential attacks. 2. The SNOW 3G algorithm is a byte-oriented stream cipher that generates processed byte streams based on input parameters, with a one-to-one correspondence between inputs and outputs. 3. Compared to the KASUMI algorithm, the SNOW 3G algorithm can process data streams more efficiently and offers higher data throughput and better compatibility. The SNOW 3G algorithm has been widely adopted in 3G and subsequent mobile communication systems, while the KASUMI algorithm is primarily used in 3G systems.
4G	SNOW 3G, AES, ZUC ²	1. Compared to the KASUMI algorithm, the AES algorithm undergoes extensive security verification, supports multiple key lengths, and offers higher computational efficiency and stronger compatibility. Consequently, the KASUMI algorithm is superseded by the AES algorithm. 2. The ZUC algorithm is an encryption algorithm independently developed by China. In the LTE Rel-11 version, the ZUC algorithm becomes the third optional encryption algorithm.
5G	SNOW 3G, AES, ZUC ³	1. The encryption algorithms used for confidentiality protection are known as NEA algorithms, which include NEA1 based on the SNOW 3G algorithm, NEA2 based on the AES algorithm, and NEA3 based on the ZUC algorithm. 2. 5G employs NIA algorithms to safeguard the integrity of the air interface, utilizing the same key length and underlying encryption algorithm as those employed for confidentiality protection. However, the keys used for integrity protection are entirely independent of those used for confidentiality protection.

In addressing security threats within SemCom, encryption techniques serve to safeguard confidentiality and integrity. Tung et al. [8] introduced the first secure SemCom scheme for wireless image transmission, which protects against eavesdropping attacks by providing resilience to chosen-plaintext attacks without assumptions about the eavesdropper's channel conditions. Recently, researchers have integrated additional technologies to protect the privacy of semantic information. Qin et al. [9] introduced a physical layer semantic encryption scheme for SemCom systems, leveraging the randomness in bilingual evaluation understudy scores from machine translation. Additionally, Luo et al. [10] developed an adversarial encryption training scheme to protect privacy while maintaining system universality and confidentiality. The designed SemCom scheme ensures transmission accuracy in both encrypted and unencrypted modes. Furthermore, Chen et al. [11] proposed a lightweight and robust SemCom system that integrates physical layer semantic encryption and adversarial identification to protect against multiple malicious attacks. Nonetheless, research on encrypting SemCom remains in its nascent stages. The application of some emerging data privacy protection technologies, such as homomorphic encryption, has yet to be thoroughly explored. Specifically, the following questions have not been answered:

Q1: What are the challenges of encrypting SemCom?

Q2: Is homomorphic encryption suitable for SemCom?

Q3: What new issues does homomorphic encryption enabled SemCom bring?

¹For more details about 3G encryption algorithms, see https://www.etsi.org/deliver/etsi_ts/133100_133199/133102/03.06.00_60/ts_133102v030600p.pdf

²For more details about 4G encryption algorithms, see https://www.etsi.org/deliver/etsi_ts/133400_133499/133401/15.07.00_60/ts_133401v150700p.pdf

³For more details about 5G encryption algorithms, see https://www.etsi.org/deliver/etsi_ts/133500_133599/133501/15.02.00_60/ts_133501v150200p.pdf

Motivated by solving these challenges, we review traditional encryption algorithms in mobile communication systems, and evaluate the feasibility of applying homomorphic encryption to SemCom. The main contributions are summarized as follows.

- We revisit classical encryption algorithms deployed from 1G to 5G, and analyze the challenges of applying traditional encryption methods to SemCom (For Q1).
- Because of the limitations of traditional encryption algorithms, we believe that the homomorphic operation nature of homomorphic encryption could be advantageous for semantic processing. Therefore, we conduct an analysis and verification of the rationale behind applying homomorphic encryption to SemCom. Firstly, we combine Scale-Invariant Feature Transform (SIFT) to verify that the homomorphic encrypted ciphertext still retains semantic information. Then, we propose a task-oriented SemCom scheme based on homomorphic encryption. Furthermore, we provide the simulation results based on open-source datasets (For Q2).
- We envision the future research direction of SemCom with homomorphic encryption empowerment (For Q3).

II. ENCRYPTION OF TRADITIONAL COMMUNICATIONS & SEMANTIC COMMUNICATIONS

A. Encryption of Mobile Communication Systems

1) *Encryption Algorithms based on Cryptography:* Encryption algorithms are mathematical methods used to convert (encrypt) data into an unreadable or difficult-to-understand format, thereby protecting the confidentiality of the data. Only users with the correct key can decrypt the data, restoring it to its original and understandable form. Encryption technologies in mobile communications are typically implemented based

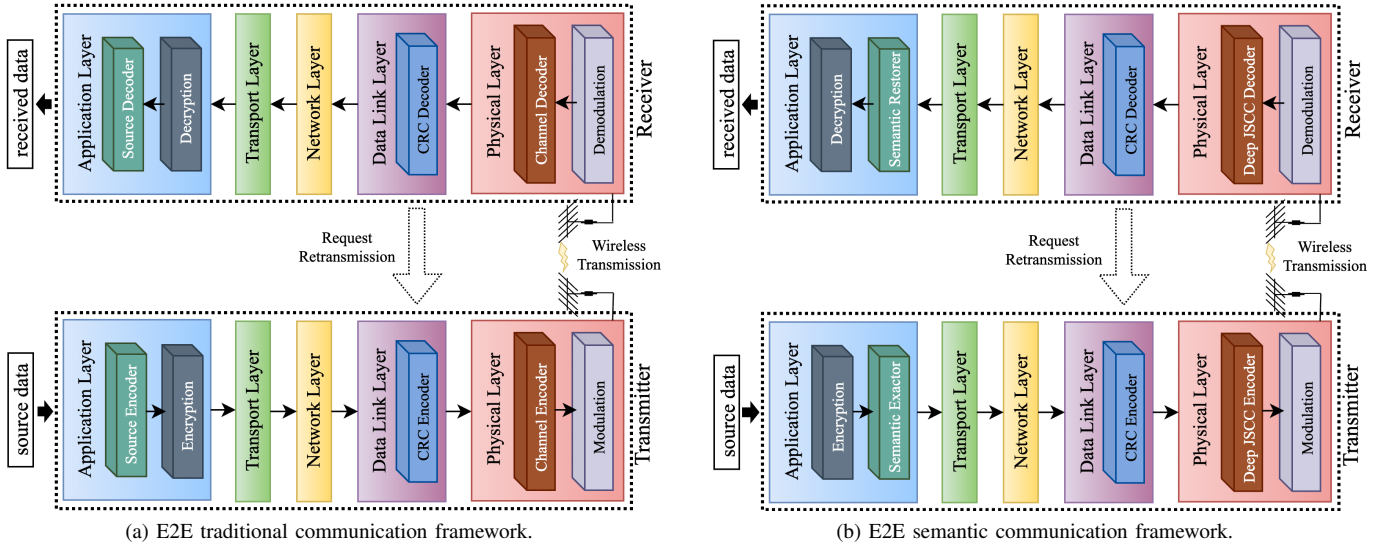

Fig. 1: A comparison between traditional E2E communication framework and semantic communication framework. Both correspond to the TCP/IP five-layer structure, which includes the application layer, transport layer, network layer, data link layer, and physical layer. Traditional communication employs a separate source and channel coding approach, conducting source coding and encryption at the application layer, and channel coding at the physical layer to reduce the bit error rate. In contrast, semantic communication uses joint source-channel coding (JSCC), where information is encrypted and semantically compressed at the application layer, then combined with channel information for coding at the physical layer.

on cryptography within upper-layer protocols, providing confidentiality and integrity security for the communication process. Tab. I illustrates the evolution of encryption algorithms in mobile communication systems. Due to technical constraints and relatively low security demands, 1G did not employ any encryption algorithms. As technology advanced and the security requirements of communication systems improved, 3G implemented the KASUMI and SNOW 3G algorithms, replacing the A5 algorithm used in 2G. The SNOW 3G, AES, and ZUC algorithms do not present any significant public security risks, and thus, 5G has retained these three encryption algorithms that were also utilized in 4G. Specifically, to achieve confidentiality and integrity protection, 5G employs New radio Encryption Algorithms (NEA) and New radio Integrity Algorithms (NIA), both of which are based on the SNOW 3G, AES, and ZUC algorithms.

- NEA: NEA facilitates secure transmission between the sender and receiver, guaranteeing end-to-end data confidentiality. By utilizing a 128-bit key length, it offers superior security compared to 64-bit encryption algorithms, rendering encrypted data more resilient to cracking attempts. Furthermore, NEA's reliance on a symmetric key system allows for swift and efficient encryption and decryption processes, making it ideal for real-time communication security protection applications. Nevertheless, despite its high security offerings, NEA encounters challenges in key management and counter synchronization.
- NIA: NIA offers a robust mechanism for data integrity protection. Through the calculation of the message authentication code and expected message authentication code, it swiftly detects tampering or damage to data, thereby ensuring the integrity of transmitted information. Additionally, the NIA algorithm excels in real-time per-

formance and efficiency, rendering it ideal for scenarios demanding swift verification of data integrity. However, it is also susceptible to security risks associated with key management and counter synchronization.

2) *Physical Layer Security (PLS) Techniques*: Physical Layer Security (PLS) techniques are grounded in information theory and are designed to protect against eavesdroppers by utilizing the inherent properties of the wireless transmission medium. PLS technology encompasses physical layer key generation and covert communications. The former relies on channel fading, noise, or unique device attributes. These characteristics are both random and unique, imparting a distinct “fingerprint” to each wireless link. Random and consistent physical-layer keys can be produced through channel probing, quantization, information reconciliation, and privacy amplification. The latter, covert communication, aims to ensure that information is securely transmitted from the sender to the receiver without detection by an eavesdropper. Its implementation hinges on various inherent or artificial uncertainties, including random and unpredictable communication environment noise and intentionally introduced interference signals. These PLS methods can also be integrated with other physical-layer technologies, such as Intelligent Reconfigurable Surface (IRS) and beamforming, to further enhance the security⁴.

B. Semantic Communication (SemCom)

Fig. 1 compares the end-to-end (E2E) traditional and semantic communication frameworks, with the main differences

⁴Despite the aforementioned advantages, PLS technologies are not the focus of this paper. As illustrated in Fig. 1, within the E2E communication framework provided, encryption is executed at the application layer rather than the physical layer. Additionally, the physical layer key generation technology is constrained by communication delays and long-distance communication performance, and the implementation of covert communication is challenging and susceptible to environmental interference.

discussed as follows. 1) Although both frameworks perform encryption and decryption at the application layer, SemCom systems require the extraction and restoration of semantic features after encryption and before decryption, respectively. This is unnecessary in traditional communication systems. 2) In contrast to the channel encoder and decoder in the physical layer of traditional communication, the deep joint source-channel coding (JSCC) in the physical layer of SemCom optimizes wireless transmission through deep learning (DL). This design overcomes the “cliff effect” inherent in traditional systems and significantly enhances transmission performance in low signal-to-noise ratio (SNR) environments. Considering these inconsistencies, we analyze the limitations of applying traditional encryption techniques in SemCom as follows.

- **The disruption of information source relevance.** Traditional encryption methods typically convert plaintext data into random ciphertext to ensure the confidentiality of information. This transformation destroys the semantic correlation in data and makes it difficult to extract the semantic information of ciphertext. However, for SemCom systems, the ability to understand and leverage the semantic information is crucial [12].
- **Influence of “avalanche effect” on communication quality.** SemCom possesses the error correction capability in information transmission, meaning it can restore data corrupted by noises. However, traditional encryption algorithms suffer from the “avalanche effect,” where a single bit error leads to incorrect decryption of all data, significantly reducing the accuracy of information transmission [13].
- **Limitations on the diversity of data operations.** SemCom requires operations such as data pre-processing, feature representation, feature selection, and parameter updating to achieve the extraction, transmission, and recovery of semantic information [4]. However, the ciphertext generated by traditional encryption algorithms cannot directly perform any arithmetic and logical operations other than decryption, thereby hindering complex data analysis and processing.

C. Challenges of Encrypting SemCom

As previously mentioned, compared to traditional communication systems, SemCom necessitates effective extraction and efficient compression of semantic features from ciphertext. The learning of these semantic features relies on the deep JSCC encoder and decoder parametrized by neural networks. Unfortunately, existing SemCom models often struggle to effectively learn the deep-level semantic features of ciphertext data. This is primarily due to the fact that traditional encryption operations significantly disrupt the original data distribution and structure, making it exceptionally challenging to directly extract meaningful semantic information from the encrypted data. Therefore, the challenge of encrypting SemCom lies in designing encryption and decryption methods that support the extraction and restoration of semantic features from ciphertext, as well as corresponding deep JSCC models.

III. HOMOMORPHIC ENCRYPTED SEMCOM

A. Homomorphic Encryption

1) *Definition and Characteristics:* Homomorphic encryption is a distinctive encryption mode in cryptography, referring to encryption algorithms that adhere to the principle of homomorphic operations on ciphertexts [14]. This encryption method enables computations to be conducted directly on encrypted data without requiring decryption first, ensuring that the decrypted outcome mirrors the result obtained by performing the same operations on plaintext data. Homomorphic encryption thus achieves the effect of “computation without visibility”, allowing processors to manipulate ciphertexts and yield encrypted results while preserving the confidentiality of the underlying data.

2) *Taxonomy:* Homomorphic encryption can be categorized into fully homomorphic encryption and partially homomorphic encryption. The former supports a wide range of computations on ciphertexts, whereas the latter restricts these operations to specific types, such as addition or multiplication, or a limited combination of such operations.

3) *Application Scenarios:* Homomorphic Encryption technique is notably applied in electronic voting systems, where voting information is homomorphically encrypted for counting, thereby safeguarding the integrity and confidentiality of the voting process. Additionally, homomorphic encryption finds utility in cloud computing, enabling users to securely delegate data processing to cloud service providers without the risk of data exposure.

4) *Motivations:* Compared with other encryption algorithms, such as Polymorphic encryption, the homomorphic computation characteristic of homomorphic encryption allows for flexible processing of encrypted data, enabling feature extraction from encrypted sources. The deep JSCC module is typically implemented with neural networks, which are known for their robust feature extraction capabilities. Neural networks abstract input data layer by layer through a multi-layer structure, thus extracting high-level semantic features. If these networks adhere to the principles of homomorphic computation, then homomorphic encryption holds significant potential for overcoming the challenges posed by encrypting SemCom.

B. Can Semantic Information Be Extracted from Homomorphic Encrypted Ciphertext?

1) *Assumption:* Here, we pose Assumption 1: “The ciphertext resulting from homomorphic encryption retains semantic information.” If Assumption 1 holds, it implies that the deep JSCC module can potentially learn the semantic features within the ciphertext. Conversely, if Assumption 1 does not hold, it would be impossible for the deep JSCC module to learn these semantic features.

2) *Validation with SIFT:* We integrate SIFT [15] to validate the plausibility of Assumption 1. First, we give an introduction to SIFT. SIFT is an algorithm used for keypoint detection and description in image processing and computer vision. The SIFT algorithm constructs a scale-space to analyze images at various scales and identify keypoints. These keypoints are



(a) Plaintext image.



(b) Detection of SIFT features in the plaintext domain.



(c) Ciphertext image obtained using a classic homomorphic encryption approach, Paillier cryptosystem.

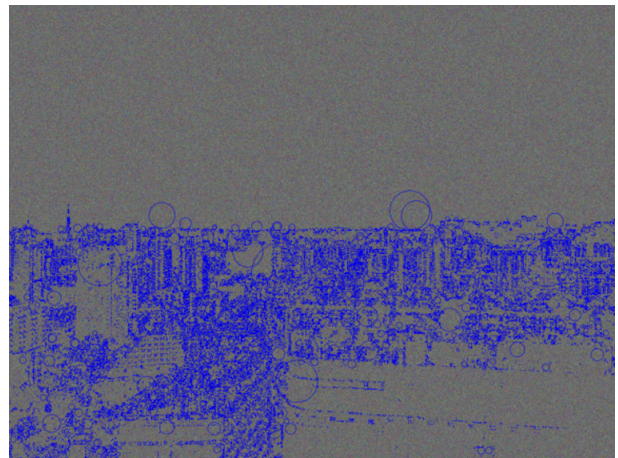

(d) Detection of SIFT features in the ciphertext domain.

Fig. 2: Illustration of the plaintext image, ciphertext image, and their SIFT detected features, where (a) plaintext image that we captured at Beijing, including multiple buildings; (b) SIFT detected features (red points) of the plaintext image, where the SIFT framework for extracting keypoints includes difference-of-Gaussian transforms, scale-space extrema detection, and keypoint localization; (c) ciphertext image obtained using Paillier cryptosystem; and (d) SIFT detected features (blue points) of the ciphertext image.

extrema points within the scale-space, exhibiting invariance to location, scale, and rotation. The first step in the SIFT algorithm is constructing a scale-space, which involves creating a series of images of the same scene at various scales by applying Gaussian blurring with different parameter levels. By examining the image at multiple scales, the algorithm detects scale-invariant keypoints, identifiable regardless of the object's size. Once the scale-space is built, the algorithm searches for local extrema (maxima or minima) as keypoints by comparing each pixel to its neighbors in both space and scale. The keypoints' locations are then refined to sub-pixel accuracy using a quadratic fit. To ensure scale invariance, the algorithm assigns an orientation to each keypoint based on the local image gradient computed within a region around it. In semantic segmentation, scale invariance is a critical property as it ensures that objects or features of different scales are accurately recognized and processed during segmentation. The scale invariance of SIFT allows it to detect identical feature points in images captured at varying resolutions and

locations, enabling SIFT to extract semantic features from images effectively.

Next, Fig. 2 shows an example of how to perform SIFT from the plaintext image and homomorphic encrypted ciphertext image. Fig. 2a displays the photograph of the building that we captured, and Fig. 2b illustrates the corresponding detected SIFT features. Fig. 2c shows the encrypted version of Fig. 2a using homomorphic encryption, and Fig. 2d provides the corresponding detected SIFT features. By comparing Fig. 2b and Fig. 2d, it is evident that the detected SIFT feature points (corner points, edge points, bright spots in dark areas, and dark spots in bright areas) in both the plaintext and ciphertext domains are almost visually identical. Consequently, the semantic information, such as SIFT features, can be extracted from the homomorphic encrypted ciphertext. Therefore, Assumption 1 is reasonable.

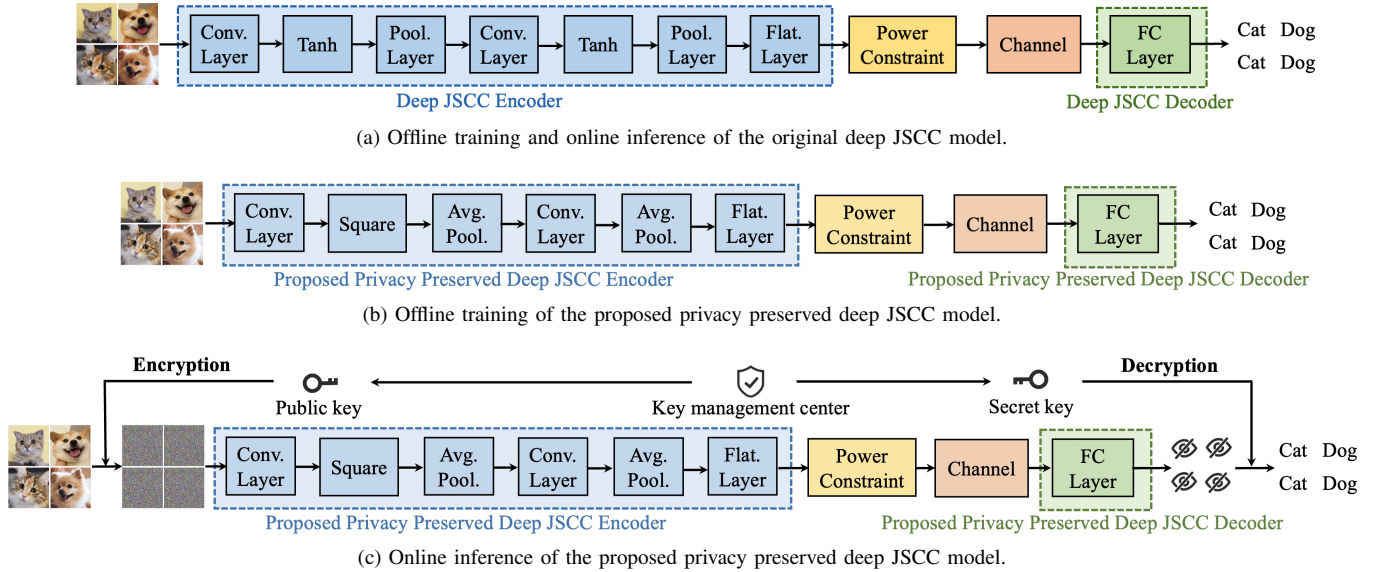

Fig. 3: Offline training and online inference of task-oriented deep JSCC models, where (a) represents the original deep JSCC model, and (b) and (c) represents the proposed deep JSCC model supporting homomorphic operations.

C. Proposed Homomorphic Encrypted SemCom Scheme

1) *Model Architecture*: Taking the classification task as an example, Fig. 3 compares the offline training and online inference phases of the original and homomorphic encryption oriented deep JSCC models. The activation functions used in deep JSCC models typically include nonlinear functions. For instance, the *ReLU* activation function cannot support homomorphic operations because it requires the use of comparison operators. Similarly, the hyperbolic tangent *tanh* function, which involves division, also cannot support homomorphic operations. Therefore, we suggest replacing these nonlinear activation functions with the square activation function $f(x) = x^2$, where all operations can be performed using addition and multiplication and are natively supported by homomorphic encryption schemes [14]. In addition, pooling layers in deep JSCC models are commonly used to reduce computational complexity and retain key semantic features. However, the max pooling layer uses comparison operators that cannot support homomorphic operations. To address this issue, various pooling algorithms can be used as alternatives to max pooling. We suggest replacing it with average pooling, as it avoids these comparisons and instead only requires the ciphertext to be multiplied by a fixed value that is known beforehand, which are well-supported in homomorphic encryption [14]. Due to the aforementioned considerations, we have improved the pooling layer and activation functions to support homomorphic operations. The detailed parameters are shown in Tab. II.

2) *Training and Inference*: As shown in Fig. 3b, the samples used in the offline training phase are unencrypted images. During this phase, the parameters of the deep JSCC codec are optimized through back propagation and gradient descent. Once the parameters are obtained, they can be deployed on both the transmitter and receiver for online inference. It is important to note that the security of parameter sharing during deployment is not the privacy concern of this paper, and

TABLE II: Parameters of the proposed privacy preserved deep JSCC model.

Module	Layer	Output Size
Privacy Preserved Deep JSCC Encoder	Conv. Layer	$1 \times 28 \times 28$
	Square	$1 \times 28 \times 28$
	Pool. Layer	$1 \times 14 \times 14$
	Flatten Layer	1×196
Channel	FC Layer	None
Privacy Preserved Deep JSCC Decoder	FC Layer	10

can be ensured by transmitting them through secret channels. As illustrated in Fig. 3c, the proposed deep JSCC models support homomorphic operations, allowing the extraction and utilization of semantic information from homomorphically encrypted images through the trained model. Additionally, only the receiver possessing the secret key can obtain the classification results through decryption.

3) *Simulation Results*: To demonstrate the effectiveness of the proposed privacy-preserved deep JSCC model, we measured and compared its classification accuracy, compression ratio, and computation time with those of the source-channel separation coding model and the original deep JSCC model. Specifically, the testing images for the source-channel separation coding model are ciphertext images, and the testing images for the original deep JSCC model are plaintext images, and the proposed privacy preserved deep JSCC model is tested with plaintext and ciphertext images respectively. The Cheon-Kim-Kim-Song scheme, a fully homomorphic encryption scheme, is utilized in this subsection. The experiments were conducted on a machine equipped with an Intel Xeon w7-2495X 48-core, 64-bit CPU and 48 GB of RAM. The experimental results, which were computed using testing images from the MNIST datasets⁵ and Fashion-MNIST datasets⁶, are detailed in Tab. III. Both of the datasets consist of 70,000 28×28 gray-scale images, with 60,000 images designed for training and 10,000 for inference. These images represent a

Datasets		MNIST				Fashion-MNIST			
Model		Model 1	Model 2	Model 3	Model 4	Model 1	Model 2	Model 3	Model 4
Classification Accuracy (Different SNRs)	0 dB	10.09%	88.73%	81.35%	81.37%	10.00%	80.50%	74.39%	74.39%
	5 dB	10.14%	90.32%	87.61%	87.60%	10.03%	81.92%	79.49%	79.47%
	10 dB	69.94%	91.13%	89.88%	89.60%	64.52%	82.53%	80.18%	80.18%
	15 dB	70.08%	91.80%	90.98%	90.96%	64.54%	83.14%	81.70%	81.70%
	20 dB	82.46%	92.11%	91.80%	91.82%	70.08%	83.23%	82.08%	82.08%
	25 dB	91.29%	92.35%	92.31%	92.33%	83.08%	83.53%	82.42%	82.41%
Compression Ratio		25.00%	25.00%	25.00%	25.00%	25.00%	25.00%	25.00%	25.00%
Comp. Time		0.4197 s	0.000173 s	0.000172 s	73.84 s	0.4236 s	0.003 s	0.000266 s	59.23 s

TABLE III: Comparison between simulation results of the source-channel separation coding model with AES encryption, the original deep JSCC model and the proposed privacy preserved deep JSCC model, where Model 1: the source-channel separation coding model with AES encryption (the source encoding and channel encoding are realized respectively by JPEG 2000 and LDPC, and the classification is achieved by the ResNet deployed at the receiver); Model 2: the original deep JSCC model on plaintext image; Model 3: the proposed privacy preserved deep JSCC model on plaintext image; and Model 4: the proposed privacy preserved deep JSCC model on homomorphic ciphertext image.

10-class classification problem, specifically, the 10 digits in MNIST and 10 fashion products in Fashion-MNIST.

Firstly, by comparing the results of Model 2 and Model 3, it is evident that the approximation of activation functions and pooling algorithms leads to a loss in classification accuracy. As SNR increases, this loss gradually becomes negligible. For instance, when $\text{SNR} = 0$, there is a 7.38% difference for MNIST datasets and a 6.11% difference for Fashion-MNIST datasets in classification accuracy, whereas at an SNR of 25, the difference in classification accuracy is only 0.04% for MNIST datasets and 1.11% for Fashion-MNIST datasets. Therefore, in low SNR environments, removing nonlinearities from deep JSCC models has a more significant impact on task performance. Secondly, the comparison between the results of Model 3 and Model 4 indicates that the proposed privacy preserved deep JSCC model performs almost identically in terms of classification accuracy for both plaintext and ciphertext images, demonstrating the effectiveness of combining the proposed model with homomorphic encryption. Thirdly, due to the ‘‘avalanche effect’’, the results of Model 1 has the worst classification accuracy, especially in low SNRs. In contrast, the proposed model leverages deep JSCC supporting homomorphic operations to realize much better classification accuracy. Fourthly, as expected, homomorphic encryption introduces significant overhead in terms of computation time.

4) *Lessons Learned*: This section has introduced the privacy preserved deep JSCC model designed to facilitate secure SemCom using homomorphic encryption, with its effectiveness confirmed through simulation results. The following insights can be gleaned from these findings: Firstly, through the approximation of activation functions and pooling algorithms, the classification accuracy of the proposed model for plaintext and homomorphic ciphertext images is almost the same. Compared with the source-channel separation coding model with AES encryption, the proposed model avoids the ‘‘avalanche effect’’ and realizes much better performance. Secondly, in low SNR environments, the classification accuracy of the proposed model is lower than that of the original deep JSCC model. To mitigate this discrepancy, further enhancing the nonlinear, pooling, and other transformation functions to support

homomorphism while preserving semantic features emerges as a promising strategy. Additionally, the complexity and computational overhead pose a significant challenge, which could potentially be addressed by leveraging GPU support and employing semantic importance-based selective encryption.

IV. FUTURE RESEARCH DIRECTION

A. Improvement of Encryption Efficiency

If all transmission content is encrypted uniformly, it would consume substantial resources and time. To enhance encryption efficiency while safeguarding critical information, selective encryption based on semantic importance can be implemented. For instance, in the case of image content, an object detection model can be utilized to identify the primary objects within the image and rank their semantic importance according to the confidence scores of the detected objects. Furthermore, a semantic segmentation model can be employed to divide the image into distinct semantic regions, with the semantic importance of each region evaluated by analyzing features such as area, color, texture, and other characteristics.

B. Enhancement of Privacy Protection

If the deep JSCC model lacks sufficient generalization capability, it will still fail to effectively protect the privacy of transmitted data. Therefore, in the future, it is necessary to integrate other techniques to enhance the deep JSCC model’s generalization ability. For instance, adversarial training generates adversarial examples by adding small and imperceptible perturbations to the input data, allowing the model to encounter a wider variety of samples during training and thus improving its generalization. Adversarial training can help the deep JSCC model find a flatter loss surface, where the loss function varies more smoothly in the parameter space. A flatter loss surface typically indicates better generalization capabilities.

C. Reduction of Computation Requirements

1) *Optimization of Homomorphic Encryption*: Firstly, future research could focus on SemCom enabled by partially homomorphic encryption. In contrast to fully homomorphic encryption, partially homomorphic encryption, such as Paillier

⁵<https://yann.lecun.com/exdb/mnist/>

⁶<https://github.com/zaladoresearch/fashion-mnist>

encryption, requires less computational power when supporting specific types of operations, such as addition. Furthermore, enhancing the mathematical operations within the encryption algorithm, for example by incorporating the Montgomery modular multiplication algorithm, can reduce computational complexity. The Montgomery modular multiplication algorithm introduces the parameter q to ensure that intermediate results can be evenly divided, allowing for division through shift operations without error, thus improving operational efficiency.

2) *Optimization of Deep JSCC Models*: Future research can delve into model compression techniques under homomorphic encryption conditions, such as pruning and knowledge distillation. Pruning involves reducing the size of the deep JSCC model by eliminating unimportant weights or neurons. Knowledge distillation is a technique that transfers the knowledge of a large model (teacher model) to a smaller model (student model). Additionally, the optimization of model complexity through transfer learning can also be explored in the future. Transfer learning leverages feature representations learned from a source task and applies these representations to a target task. In transfer learning, the lower-level parameters of the pre-trained deep JSCC model are usually frozen, and only the top-level classifier or regressor is retrained.

D. Enhancement of Computation Support

Multi-core processing units, such as GPUs and FPGAs, or customized chips (ASICs), offer enhanced computational power support for deep JSCC models under homomorphic encryption conditions. GPUs are celebrated for their robust parallel computing capabilities, making them highly suitable for accelerating both the training and inference processes of deep JSCC models. Within homomorphically encrypted SemCom, GPUs can expedite both the encryption and decryption processes as well as computations on the ciphertext. FPGAs are programmable hardware platforms that can be tailored to meet specific computing demands, providing higher energy efficiency ratios and lower latencies compared to GPUs. ASICs, which are chips designed for specific applications, can be highly optimized for particular tasks.

V. CONCLUSIONS

As a novel communication paradigm, SemCom significantly reduces bandwidth requirements and enhances the reliability of communication systems through efficient and accurate semantic extraction, transmission, and recovery. However, the urgent security issues in semantic communication, such as privacy leakage of semantic data and damage to semantic data integrity, need to be addressed. In this paper, we have first revisited commercial encryption algorithms from 1G to 5G, including the A5, KASUMI, SNOW 3G, AES, and ZUC algorithms. Then, we have analyzed the limitations of applying these algorithms in SemCom and point out the challenges of encrypting SemCom. Due to the homomorphic operation characteristic of homomorphic encryption, we have demonstrated it to be a promising solution. We apply SIFT to verify the semantic features can be preserved in homomorphically encrypted

ciphertext. Based on this finding, we have developed a task-oriented SemCom approach secured through homomorphic encryption and verify its effectiveness through simulations. We have further provided future research directions, including improving encryption efficiency, bolstering privacy protection, reducing computation requirements, and enhancing computation support.

VI. ACKNOWLEDGMENT

The work presented in this paper was supported by the National Key R&D Program of China No. 2020YFB1806905, the National Natural Science Foundation of China No. 61871045 and No. 61932005, Beijing Natural Science Foundation No. L242012, and the research foundation of Ministry of Education-China Mobile under Grant MCM20180101.

REFERENCES

- [1] C. X. Wang, X. You, X. Gao, X. Zhu, Z. Li, C. Zhang, H. Wang, Y. Huang, Y. Chen, H. Haas, J. S. Thompson, E. G. Larsson, M. D. Renzo, W. Tong, P. Zhu, X. Shen, H. V. Poor, and L. Hanzo, "On the Road to 6G: Visions, Requirements, Key Technologies and Testbeds," *IEEE Communications Surveys and Tutorials*, vol. 25, no. 2, pp. 905–974, 2023.
- [2] P. Zhang, W. Xu, Y. Liu, X. Qin, K. Niu, S. Cui, G. Shi, Z. Qin, X. Xu, F. Wang *et al.*, "Intellicise wireless networks from semantic communications: A survey, research issues, and challenges," *IEEE Communications Surveys & Tutorials*, 2024.
- [3] R. Meng, S. Gao, D. Fan, H. Gao, Y. Wang, X. Xu, B. Wang, S. Lv, Z. Zhang, M. Sun *et al.*, "A survey of secure semantic communications," *arXiv preprint arXiv:2501.00842*, 2025.
- [4] S. Guo, Y. Wang, N. Zhang, Z. Su, T. H. Luan, Z. Tian, and X. Shen, "A survey on semantic communication networks: Architecture, security, and privacy," *IEEE Communications Surveys & Tutorials*, 2024.
- [5] M. Shen, J. Wang, H. Du, D. Niyato, X. Tang, J. Kang, Y. Ding, and L. Zhu, "Secure semantic communications: Challenges, approaches, and opportunities," *IEEE Network*, vol. 38, no. 4, pp. 197–206, 2024.
- [6] H. Du, J. Wang, D. Niyato, J. Kang, Z. Xiong, M. Guizani, and D. I. Kim, "Rethinking wireless communication security in semantic internet of things," *IEEE Wireless Communications*, vol. 30, no. 3, pp. 36–43, 2023.
- [7] Z. Yang, M. Chen, G. Li, Y. Yang, and Z. Zhang, "Secure semantic communications: Fundamentals and challenges," *IEEE Network*, vol. 38, no. 6, pp. 513–520, 2024.
- [8] T.-Y. Tung and D. Gündüz, "Deep joint source-channel and encryption coding: Secure semantic communications," in *ICC 2023-IEEE International Conference on Communications*. IEEE, 2023, pp. 5620–5625.
- [9] Q. Qin, Y. Rong, G. Nan, S. Wu, X. Zhang, Q. Cui, and X. Tao, "Securing semantic communications with physical-layer semantic encryption and obfuscation," in *ICC 2023-IEEE International Conference on Communications*. IEEE, 2023, pp. 5608–5613.
- [10] X. Luo, Z. Chen, M. Tao, and F. Yang, "Encrypted semantic communication using adversarial training for privacy preserving," *IEEE Communications Letters*, vol. 27, no. 6, pp. 1486–1490, 2023.
- [11] G. Chen, G. Nan, Z. Jiang, H. Du, R. Shi, Q. Cui, and X. Tao, "Lightweight and robust wireless semantic communications," *IEEE Communications Letters*, 2024.
- [12] A. Li, S. Wu, S. Meng, R. Lu, S. Sun, and Q. Zhang, "Toward goal-oriented semantic communications: New metrics, framework, and open challenges," *IEEE Wireless Communications*, 2024.
- [13] K. D. Muthavhine and M. Sumbwanyambe, "An analysis and a comparative study of cryptographic algorithms used on the internet of things (iot) based on avalanche effect," in *2018 International Conference on Information and Communications Technology (ICOIAC)*. IEEE, 2018, pp. 114–119.
- [14] A. Falcetta and M. Roveri, "Privacy-preserving deep learning with homomorphic encryption: An introduction," *IEEE Computational Intelligence Magazine*, vol. 17, no. 3, pp. 14–25, 2022.
- [15] C.-Y. Hsu, C.-S. Lu, and S.-C. Pei, "Image feature extraction in encrypted domain with privacy-preserving sift," *IEEE Transactions on Image Processing*, vol. 21, no. 11, pp. 4593–4607, 2012.