

# String commitment from unstructured noisy channels

Jiawei Wu<sup>1</sup>, Masahito Hayashi<sup>2,3,4</sup>, and Marco Tomamichel<sup>1,5</sup>

<sup>1</sup>*Centre for Quantum Technologies, National University of Singapore, Singapore*

<sup>2</sup>*The Chinese University of Hong Kong, Shenzhen, Longgang District, Shenzhen, 518172, China*

<sup>3</sup>*International Quantum Academy, Futian District, Shenzhen 518048, China*

<sup>4</sup>*Graduate School of Mathematics, Nagoya University, Chikusa-ku, Nagoya 464-8602, Japan*

<sup>5</sup>*Department of Electrical and Computer Engineering, National University of Singapore, Singapore*

## Abstract

Noisy channels are valuable resources for cryptography, enabling information-theoretically secure protocols for cryptographic primitives like bit commitment and oblivious transfer. While existing work has primarily considered memoryless channels, we consider more flexible channel resources that a dishonest player can configure arbitrarily within some constraints on their min-entropy. We present a protocol for string commitment over such channels that is complete, hiding, and binding, and derive its achievable commitment rate, demonstrating the possibility of string commitment in noisy channels with a stronger adversarial model. The asymptotic commitment rate coincides with previous results when the adversarial channels are the same binary symmetric channel as in the honest case.

## 1 Introduction

Commitments are a foundational concept in cryptography, serving as a critical component for various cryptographic applications, such as coin flipping [Blu83, DM13], zero-knowledge proofs [BCC88, GMW91], and secure multiparty computation [CDN20, BOCG+06, DNS10, GMW19]. This cryptographic primitive allows a party, Alice, to commit to a specific value (usually a bit or bit string) in a way that keeps the value hidden from another party, Bob, until a later point when Alice chooses to reveal the committed value. The two critical properties of commitments are the hiding and the binding properties. (1) The hiding property ensures that Bob is ignorant of the committed value during the commit phase. (2) The binding property ensures that, once the commitment has been established, Alice is precluded from altering the value she intends to disclose. A common analogy for commitment involves Alice locking a message inside a container and sending it to Bob. At this stage, Bob remains unaware of the actual content of the message. Later, upon Alice's provision of the corresponding key, Bob can unlock the container and verify the committed value.

The study of commitment traces back to Blum's foundational work [Blu83], where commitment is used to implement coin flipping and is shown to be secure under the assumption that factoring is hard. Indeed, in classical settings, commitments can be achieved under the assumption of a computationally bounded adversary. Moreover, commitments are also possible under certain communication constraints, for example those imposed by special relativity [Ken99, CK12, KTHW13] (see also [LKB<sup>+</sup>13, LKB<sup>+</sup>15] for implementations of such protocols). However, in absence of such assumptions, even allowing for quantum computation and communication, commitments become impossible without additional resources [LC97, May97, LC98]. It is not even possible use string commitments as a resource to commit to a longer string [WTHR11].

Research has since explored how inherent noise in communication channels, independent of adversarial influence, can be used as a resource to enable cryptographic tasks. Wyner's wiretap channel model [Wyn75] and its generalization [CK78] utilize the noisy gap between two channels to implement secure communication in the presence of an eavesdropper. More recent works demonstrate that noisy channels can support various two-party cryptographic protocols, including string commitment [Cré97, WNI03, CMW05, HW22, HW23] and oblivious transfer [CMW05, IKO<sup>+</sup>11, DN17]. In more realistic scenarios, adversaries may have partial control over the channel, potentially influencing

its error rate. Studies on “unfair” noisy channels [DKS99, CDLR16, KMS16, CDN20] examine the feasibility of cryptographic protocols under such conditions, but rely on the assumption that the channel remains memoryless even under adversarial conditions.

This paper addresses string commitment task with a channel resource that allows more general manipulations by adversarial parties. It can be informally described as follows: If Alice and Bob are both honest, the channel is a memoryless binary symmetric channel (BSC); however, any dishonest party can arbitrarily manipulate the channel in such a way that correlations between the different channel uses are introduced and the channel is thus no longer memoryless, as long as the channel is subject to some constraints on its entropy generation. Inspired by the protocols in [WNI03] and [IMANW06], we propose a string commitment protocol that satisfies both hiding property (see Theorem 4) and binding property (see Theorem 6). When the dishonest party’s channel is fixed as the same BSC as in the honest scenario, our protocol achieves a commitment rate that coincides with previous results [WNI03, IMNW04].

## 2 Notations and definitions

For a finite set  $\mathcal{X}$ , let  $\Delta(\mathcal{X})$  be the probability simplex and  $\Delta_{\leq}(\mathcal{X})$  be the subnormalized simplex. They are defined as

$$\Delta(\mathcal{X}) := \left\{ P : \mathcal{X} \rightarrow [0, 1] \left| \sum_{x \in \mathcal{X}} P(x) = 1 \right. \right\},$$

$$\Delta_{\leq}(\mathcal{X}) := \left\{ P : \mathcal{X} \rightarrow [0, 1] \left| \sum_{x \in \mathcal{X}} P(x) \leq 1 \right. \right\}.$$

The elements in  $\Delta_{\leq}$  are called subnormalized distribution. The uniform distribution in  $\Delta(\mathcal{X})$  is denoted by  $U_{\mathcal{X}}$ .

For two discrete probability distributions  $P, Q$  on set  $\mathcal{X}$ , their generalized total variational distance is defined as

$$\begin{aligned} \text{TD}(P, Q) &:= \frac{1}{2} \|P - Q\|_1 + \frac{1}{2} \left| \|P\|_1 - \|Q\|_1 \right| \\ &= \frac{1}{2} \sum_{x \in \mathcal{X}} |P(x) - Q(x)| + \frac{1}{2} \left| \sum_{x \in \mathcal{X}} P(x) - Q(x) \right|. \end{aligned} \quad (1)$$

It is shown in [Tom15, Section 3.1.2] that  $\text{TD}(\cdot, \cdot)$  is a metric. If  $P, Q$  are normalized, then  $\text{TD}(P, Q)$  reduces to the normal total variational distance.

We denote the Shannon entropy of random variable  $X$  subjected to distribution  $P_X$  as  $H(X)_P$ . This notation applies to all variants of entropic quantities. For  $P_X \in \Delta_{\leq}(\mathcal{X})$  and  $P_{XZ} \in \Delta_{\leq}(\mathcal{X} \times \mathcal{Z})$ , the min-entropy and conditional min-entropy are respectively defined as:

$$H_{\min}(X)_P := -\log \max_{x \in \mathcal{X}} P_X(x), \quad (2)$$

$$H_{\min}(X|Z)_P := -\log \sum_{z \in \mathcal{Z}} P_Z(z) \max_{x \in \mathcal{X}} P_{X|Z}(x|z), \quad (3)$$

where the log is taken with base 2. Accordingly, the smooth min-entropy and the smooth conditional min-entropy are respectively defined as

$$H_{\min}^{\varepsilon}(X)_P := \max_{\substack{Q_X \in \Delta_{\leq}(\mathcal{X}) \\ \text{TD}(P_X, Q_X) \leq \varepsilon}} H_{\min}(X)_Q, \quad (4)$$

$$H_{\min}^{\varepsilon}(X|Z)_P := \max_{\substack{Q_{XZ} \in \Delta_{\leq}(\mathcal{X} \times \mathcal{Z}) \\ \text{TD}(P_{XZ}, Q_{XZ}) \leq \varepsilon}} H_{\min}(X|Z)_Q. \quad (5)$$

A channel  $\omega : \mathcal{X} \rightarrow \mathcal{Z}, X \mapsto Z$  is characterized by conditional probability distribution  $\omega(\cdot|x)$ .  $\omega(z|x)$  denotes the exact value of distribution  $\omega(x)$  at point  $z$ , and  $\omega(x)$  denotes the output distribution given input  $x$ .  $\omega$  is called subnormalized if  $\forall x \in \mathcal{X}, \omega(x) \in \Delta_{\leq}(\mathcal{Z})$ . For random variable  $X$  subjected to  $P_X \in \Delta_{\leq}(\mathcal{X})$ ,  $\omega \times P_X$  denotes the joint distribution  $P_{XZ}$ , where  $P_{XZ}(x, z) = P_X(x)\omega(z|x)$ , and

$\omega \circ P_X$  denotes the marginal output distribution, that is,  $P_Z(\cdot) = \sum_x P_{XZ}(x, \cdot)$ . For two channels  $\omega_1 : X \mapsto Y, \omega_2 : Y \mapsto Z$ ,  $\omega_2 \circ \omega_1$  denotes their concatenation.

The distance between two subnormalized channels,  $W$  and  $W'$ , is characterized by diamond norm:

$$\|W - W'\|_{\diamond} := \max_{x \in \mathcal{X}} \text{TD}(W(\cdot|x), W'(\cdot|x)).$$

The reverse min-entropy of subnormalized channel  $W : \mathcal{X} \rightarrow \mathcal{Z}$  is defined as

$$\overleftarrow{H}_{\min}(W) := H_{\min}(X|Z)_{W \times U_{\mathcal{X}}}. \quad (6)$$

The smooth reverse min-entropy of  $W$  is defined as

$$\overleftarrow{H}_{\min}^{\varepsilon}(W) := \max_{W' : \|W - W'\|_{\diamond} \leq \varepsilon} \overleftarrow{H}_{\min}(W'), \quad (7)$$

where  $W'$  is a subnormalized channel.

We also need the concept of strongly conditional typical set. The sequence  $x_1 x_2 \dots x_n$  is denoted by  $\mathbf{x}$  whenever the length  $n$  is obvious from the context. For an input sequence  $\mathbf{x} \in \mathcal{X}^n$  and the channel  $W : \mathcal{X} \rightarrow \mathcal{Z}$ , the strongly conditional typical set is defined as

$$\mathcal{T}_{W, \varepsilon}^n(\mathbf{x}) := \{\mathbf{z} \in \mathcal{Z}^n \mid \forall x, z, |P_{\mathbf{x}, \mathbf{z}}(x, z) - W(z|x)P_{\mathbf{x}}(x)| \leq \varepsilon \wedge W(z|x) = 0 \implies P_{\mathbf{x}, \mathbf{z}}(x, z) = 0\}, \quad (8)$$

where  $P_{\mathbf{x}}$  and  $P_{\mathbf{x}, \mathbf{z}}$  are the empirical distribution of  $\mathbf{x}$  and  $(\mathbf{x}, \mathbf{z})$ , respectively. The following lemma gives the unit probability property of strongly conditional typical set.

**Lemma 1** ([WNI03, inequality (13)]). *Let  $W : \mathcal{X} \rightarrow \mathcal{Z}$  be a discrete memoryless channel. For any  $\mathbf{x} \in \mathcal{X}^n$  and  $\varepsilon > 0$ ,*

$$\Pr_{\mathbf{z} \sim W^n(\mathbf{x})}[\mathbf{z} \in \mathcal{T}_{W, \varepsilon}^n(\mathbf{x})] \geq 1 - 2|\mathcal{X}||\mathcal{Z}|2^{-n\varepsilon^2}.$$

Additionally, we introduce the Gilbert bound [Lev71, inequality (25)] (see also [Sam01, inequality (2)]) on constant weight code.

**Lemma 2.** *Let  $A(n, d, w)$  be the maximal size of a constant-weight code  $\mathcal{C} \subseteq \{0, 1\}^n$  with Hamming distance  $d$  and weight  $w$ . Then for  $\sigma, \zeta \in [0, 1]$ , it satisfies*

$$\frac{1}{n} \log A(n, 2\sigma n, \zeta n) \geq h(\zeta) - \zeta h\left(\frac{\sigma}{\zeta}\right) - (1 - \zeta) h\left(\frac{\sigma}{1 - \zeta}\right) + o(1).$$

### 3 Task definition

We will consider string commitment task with a noisy channel  $\mathcal{W} : \mathcal{X}^n \rightarrow \mathcal{Z}^n$  from Alice to Bob, where  $\mathcal{X} = \mathcal{Z} = \{0, 1\}$ , and a free bidirectional noiseless channel. When the noisy channel is used  $n$  times, it behaves as follows:

**(C1)** If both Alice and Bob are honest,  $\mathcal{W}$  is an  $n$ -fold BSC  $W^n$ , where  $W : \mathcal{X} \rightarrow \mathcal{Z}$  with transition probability  $p$  ( $p < 1/2$ ).

**(C2)** If Alice is dishonest, she can manipulate the channel to  $W^A : \mathcal{X}^n \rightarrow \mathcal{Z}^n$  under the constraint:  $\forall \mathbf{x} \in \mathcal{X}^n, H_{\min}^{\varepsilon_A}(\mathbf{Z})_{W^A(\mathbf{x})} \geq l_A$ .

**(C3)** If Bob is dishonest, he can manipulate the channel to  $W^B : \mathcal{X}^n \rightarrow \mathcal{Z}^n$  under the constraint:  $\overleftarrow{H}_{\min}^{\varepsilon_B}(W^B) \geq l_B$ .

The above conditions are parameterized by the set of parameters  $\theta := (p, \varepsilon_A, l_A, \varepsilon_B, l_B)$ . In the following, we call the above condition the channel condition with  $\theta$ .

A string commitment protocol consists of a commit phase and a reveal phase. Each phase involves certain rounds of interactions while the commit phase includes additional use of the noisy channel. Alice needs to commit a message  $m \in \mathcal{M}$  in the commit phase and reveal it in reveal phase.

A general string commitment protocol can be described by interactive random systems  $\alpha_C, \alpha_R, \beta_C, \beta_R$ , as shown in Figure 1(a). In the reveal phase, honest Bob's system  $\beta_R$  outputs the revealed message  $\hat{M}$  and a flag bit  $F \in \{\text{"acc"}, \text{"rej"}\}$  representing accepting or rejecting the message.

The requirements for string commitment are:

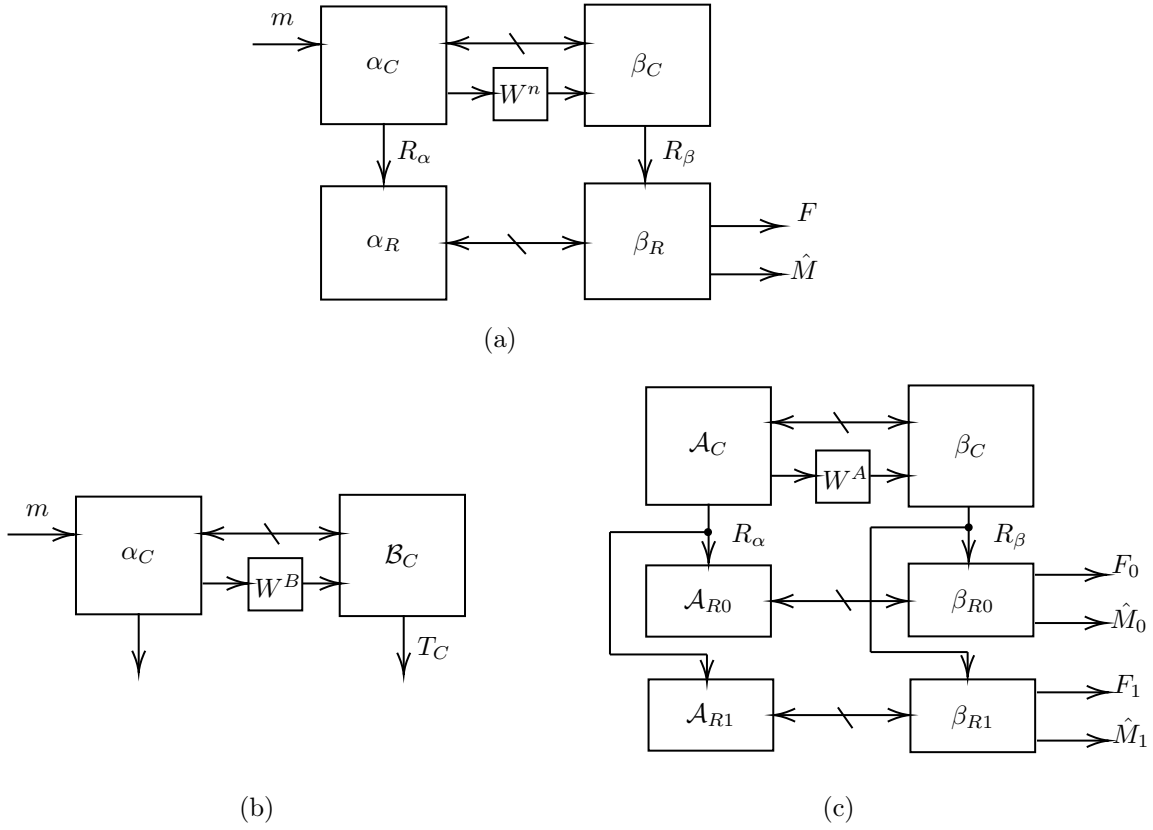

Figure 1: (a) The honest protocol is modelled by random interactive systems.  $\alpha_C, \alpha_R$  are Alice's protocol in the commit phase and reveal phase.  $\beta_C, \beta_R$  are Bob's protocol in the commit phase and reveal phase. The arrow  $\leftrightarrow$  denotes multi-rounds of interactions through the noiseless channel. The order of the use of noiseless channel and the use of noisy channel  $W$  can be arbitrary. Variables  $R_\alpha, R_\beta$  denote all registers of system  $\alpha_C, \beta_C$ , respectively.  $\hat{M}$  is the message inferred by  $\beta_R$ .  $F \in \{\text{"acc"}, \text{"rej"}\}$  is a flag representing the acceptance or rejection of the revealed message. (b) An illustration of dishonest Bob in the commit phase.  $T_C$  is the Bob's transcript after interacting with Alice through  $\mathcal{B}_C$ . (c) An illustration of dishonest Alice.  $\mathcal{A}_{R0}, \mathcal{A}_{R1}$  and  $\mathcal{A}_C$  are interactive systems representing Alice's strategy.  $\beta_{R0}$  and  $\beta_{R1}$  are two copies of  $\beta_R$ .

1. Completeness: When both Alice and Bob are honest, the protocol proceeds as in Figure 1(a). The completeness parameter  $\delta_{c,\theta}(\Phi)$  is defined as

$$\delta_{c,\theta}(\Phi) := \max_{m \in \mathcal{M}} 1 - \Pr[\hat{M} = m \wedge F = \text{“acc”}].$$

2. Hiding: When Bob is dishonest, denote his cheating strategy at commit phase as  $\mathcal{B}_C$ . As shown in Figure 1(b),  $\mathcal{B}_C$  is a probabilistic system that interacts with honest Alice’s system  $\alpha_C$ . Let  $T_C$  be the transcripts of Bob at the end of commit phase when Bob applies strategy  $\mathcal{B}_C$ . The hiding parameter  $\delta_{h,\theta}(\Phi)$  is defined as

$$\delta_{h,\theta}(\Phi) := \max_{\mathcal{B}_C} \max_{m \neq m' \in \mathcal{M}} \text{TD}(P_{T_C|m}, P_{T_C|m'}).$$

3. Binding: This condition corresponds to soundness from Bob’s viewpoint. When Alice is dishonest, she applies the cheating strategy  $\mathcal{A}_C$  to interact with  $\beta_C$  in the commit phase and two strategies  $\mathcal{A}_{R0}, \mathcal{A}_{R1}$  to interact with  $\beta_{R0}, \beta_{R1}$  respectively in the reveal phase, as shown in Figure 1(c). Alice succeeds when two different messages are accepted by Bob. Thus, the binding parameter  $\delta_{b,\theta}(\Phi)$  is defined as

$$\delta_{b,\theta}(\Phi) := \max_{\mathcal{A}_C, \mathcal{A}_{R0}, \mathcal{A}_{R1}} \Pr \left[ \begin{array}{l} F_0 = F_1 = \text{“acc”} \wedge \\ \hat{M}_0 \neq \hat{M}_1 \end{array} \right],$$

where  $F_0, F_1, \hat{M}_0, \hat{M}_1$  are the output variables of  $\beta_{R0}$  and  $\beta_{R1}$ .

We aim to find a protocol  $\Phi$  such that  $\delta_{c,\theta}(\Phi)$ ,  $\delta_{h,\theta}(\Phi)$ , and  $\delta_{b,\theta}(\Phi)$  are sufficiently small. The string commitment rate is defined as

$$R = \frac{\log |\mathcal{M}|}{n}.$$

A rate  $R$  is said to be achievable with the channel parameter  $\{\theta_n\}_{n \in \mathbb{N}}$  if for any  $R' < R$  there exists a sequence of protocol  $\{\Phi_n\}_{n \in \mathbb{N}}$  such that  $\Phi_n$  uses the channel  $n$  times on message set  $\mathcal{M}_n$  and

$$\begin{aligned} \lim_{n \rightarrow \infty} \delta_{c,\theta_n}(\Phi_n) &= 0, \\ \lim_{n \rightarrow \infty} \delta_{h,\theta_n}(\Phi_n) &= 0, \\ \lim_{n \rightarrow \infty} \delta_{b,\theta_n}(\Phi_n) &= 0, \\ \lim_{n \rightarrow \infty} \frac{\log |\mathcal{M}_n|}{n} &= R'. \end{aligned}$$

## 4 A string commitment protocol

In this section we will describe our string commitment protocol and show its completeness, hiding property and binding property.

Suppose  $\varepsilon > 0$  is an arbitrarily small number,  $\mathcal{M}$  is the message set with an additive group structure.  $\mathcal{C} \subset \{0, 1\}^n$  is a code with Hamming distance  $d_H(\mathcal{C}) = d < n/2$ , where  $d_H(\mathcal{C}) := \min_{\mathbf{x} \neq \mathbf{y} \in \mathcal{C}} d_H(\mathbf{x}, \mathbf{y})$ , and  $F = \{f_s\}_{s \in \mathcal{S}} : \mathcal{C} \rightarrow \mathcal{M}$  is a balanced 2-universal hash function (UHF) family<sup>1</sup>. While UHF family can be constructed with linear map [CW79], the code  $\mathcal{C}$  is not necessarily linear. Define the random map  $\Gamma_s : \mathcal{M} \rightarrow \mathcal{C}$  as

$$\Gamma_s(c|m) = \frac{|\mathcal{M}|}{|\mathcal{C}|} \mathbb{1}[f_s(c) = m],$$

where  $\mathbb{1}[\cdot]$  is the indicator function.

With the above preparation, we propose Protocol 1, denoted by  $\Phi[\varepsilon, \mathcal{C}, F]$ . The completeness of this protocol is shown in Theorem 3.

<sup>1</sup>The function family  $\{f_s\}_{s \in \mathcal{S}} : \mathcal{C} \rightarrow \mathcal{M}$  is a balanced 2-universal hash function family if (1)  $\forall m, m' \in \mathcal{M}, s \in \mathcal{S}, |f_s^{-1}(m)| = |f_s^{-1}(m')|$  and (2)  $\forall c_1 \neq c_2 \in \mathcal{C}, \Pr[f_S(c_1) = f_S(c_2)] \leq 1/|\mathcal{M}|$  when  $S$  is uniformly distributed on  $\mathcal{S}$ .

---

**Protocol 1** String commitment protocol from non-i.i.d. noisy channel
 

---

**Commit phase:**

- To commit to message  $m \in \mathcal{M}$ , Alice first generates uniformly random variables  $S \in_R \mathcal{S}$  and  $\bar{M} \in_R \mathcal{M}$ . Then she computes  $\underline{M} = m + \bar{M}$ , applies the random map  $\Gamma_S$  to  $\underline{M}$  to get  $\mathbf{X}$ , and sends  $\mathbf{X}$  through the noisy channel. Later, Alice sends  $S, \bar{M}$  via noiseless channel.
- Bob keeps  $S, \bar{M}$  and the channel output  $\mathbf{Z}$  as the commitment.

**Reveal phase:**

- Alice announces  $(m, \mathbf{X})$ . Bob outputs  $\hat{M} = m$  and tests if  $\mathbf{X} \in \mathcal{C}, \mathbf{Z} \in \mathcal{T}_{W, \varepsilon}^n(\mathbf{X}), f_S(\mathbf{X}) = m + \bar{M}$ . If the test passes, Bob outputs  $F = \text{“acc”}$ , else  $F = \text{“rej”}$ .
- 

**Theorem 3.** *The completeness parameter of the protocol  $\Phi[\varepsilon, \mathcal{C}, F]$  satisfies*

$$\delta_{c, \theta}(\Phi[\varepsilon, \mathcal{C}, F]) \leq 8 \cdot 2^{-n\varepsilon^2}. \quad (9)$$

*Proof.*

$$\begin{aligned} \delta_{c, \theta}(\Phi) &= \max_{m \in \mathcal{M}} 1 - \Pr[\hat{M} = m \wedge F = \text{“acc”}] \\ &= \max_{m \in \mathcal{M}} 1 - \Pr[\mathbf{X} \in \mathcal{C} \wedge \mathbf{Z} \in \mathcal{T}_{W, \varepsilon}^n(\mathbf{X}) \wedge f_S(\mathbf{X}) = m + \bar{M}] \\ &\leq \max_{m \in \mathcal{M}, s \in \mathcal{S}} \max_{\mathbf{x} \in \tilde{f}_s^{-1}(m)} 1 - \Pr_{\mathbf{z} \sim W^n(\mathbf{x})}[\mathbf{z} \in \mathcal{T}_{W, \varepsilon}^n(\mathbf{x})] \\ &\leq 8 \cdot 2^{-n\varepsilon^2}, \end{aligned} \quad (10)$$

where inequality (10) follows from Lemma 1.  $\square$

## 4.1 Hiding

**Theorem 4 (Hiding).** *The hiding parameter of the protocol  $\Phi[\varepsilon, \mathcal{C}, F]$  with channel parameter  $\theta = (p, \varepsilon_A, l_A, \varepsilon_B, l_B)$  satisfies*

$$\delta_{h, \theta}(\Phi[\varepsilon, \mathcal{C}, F]) \leq 2 \cdot 2^{\frac{1}{2}(n + \log |\mathcal{M}| - \log |\mathcal{C}| - l_B)} + 4\varepsilon_B. \quad (11)$$

*Proof.* Because Bob only receives messages in the commit phase, the transcript of Bob  $T_C$  is independent of Bob’s strategy  $\mathcal{B}_C$ . We prove the theorem in three steps.

**Step 1:** Transform the target quantity  $\delta_{h, \theta}(\Phi)$  into the standard privacy amplification form.

Denote the probabilistic map  $W^B \circ \Gamma_S : \mathcal{M} \rightarrow \mathcal{Z}^n$  by  $\phi_S$ .  $\bar{\phi}_S = \sum_{m \in \mathcal{M}} \phi_S(m) / |\mathcal{M}|$  is the averaged marginal distribution on  $\mathcal{Z}^n$ . Recall that  $\phi_S(m)$  denotes the output distribution and  $\phi_S(\mathbf{z}|m)$  denotes

the conditional probability. Then for any  $m \neq m' \in \mathcal{M}$ ,

$$\begin{aligned}
\text{TD}(P_{T_C|m}, P_{T_C|m'}) &= \frac{1}{2} \|P_{\mathbf{Z}S\bar{M}|M=m} - P_{\mathbf{Z}S\bar{M}|M=m'}\|_1 \\
&= \frac{1}{2} \sum_{\bar{m} \in \mathcal{M}, \mathbf{z} \in \{0,1\}^n} \mathbb{E}_S \left| P_{\mathbf{Z}\bar{M}|MS}(\mathbf{z}, \bar{m}|m, S) - P_{\mathbf{Z}\bar{M}|MS}(\mathbf{z}, \bar{m}|m', S) \right| \\
&= \frac{1}{2} \sum_{\bar{m} \in \mathcal{M}, \mathbf{z} \in \{0,1\}^n} \mathbb{E}_S |P_{\bar{M}}(\bar{m})\phi_S(\mathbf{z}|m + \bar{m}) - P_{\bar{M}}(\bar{m})\phi_S(\mathbf{z}|m' + \bar{m})| \quad [\bar{M} \text{ is independent of } M, S] \\
&= \frac{1}{2|\mathcal{M}|} \sum_{\bar{m} \in \mathcal{M}} \mathbb{E}_S \|\phi_S(m + \bar{m}) - \phi_S(m' + \bar{m})\|_1 \quad [P_{\bar{M}} = U_{\mathcal{M}}] \\
&\leq \frac{1}{2|\mathcal{M}|} \sum_{\bar{m} \in \mathcal{M}} \mathbb{E}_S [\|\phi_S(m + \bar{m}) - \bar{\phi}_S\|_1 + \|\phi_S(m' + \bar{m}) - \bar{\phi}_S\|_1] \quad [\text{Triangle inequality}] \\
&= \frac{1}{|\mathcal{M}|} \sum_{\underline{m} \in \mathcal{M}} \mathbb{E}_S \|\phi_S(\underline{m}) - \bar{\phi}_S\|_1 \quad [\text{Group rearrangement}] \\
&= \mathbb{E}_S \|\phi_S \times U_{\mathcal{M}} - \bar{\phi}_S U_{\mathcal{M}}\|_1 \\
&= \mathbb{E}_S \|f_S(W^B \times U_C) - \bar{\phi}_S U_{\mathcal{M}}\|_1, \quad [f_S \text{ is balanced}] \quad (12)
\end{aligned}$$

where  $f_S(\cdot)$  denotes the distribution of  $\cdot$  after applying  $f_S$ . Recall that  $\phi_S \times U_{\mathcal{M}}$  denotes the joint distribution of both the input and output of the random map  $\phi_S$ .

**Step 2:** Applying the smoothed version [Ren08, Corollary 5.6.1] of leftover hash lemma [BBCM95, HILL99] to equation (12), we have

$$\mathbb{E}_S \|f_S(W^B \times U_C) - \bar{\phi}_S U_{\mathcal{M}}\|_1 \leq 2 \cdot 2^{\frac{1}{2}(\log |\mathcal{M}| - H_{\min}^{\varepsilon_B}(\mathbf{X}|\mathbf{Z})_{W^B \times U_C})} + 4\varepsilon_B, \quad (13)$$

where we have chosen the specific smoothing parameter  $\varepsilon_B$ .

**Step 3:** Estimate  $H_{\min}^{\varepsilon_B}(\mathbf{X}|\mathbf{Z})_{W^B \times U_C}$  with  $\overleftarrow{H}_{\min}^{\varepsilon_B}(W^B)$ .

By definition of  $H_{\min}^{\varepsilon_B}(W^B)$  in equation (7), there exists a subnormalized channel  $\tilde{W}^B$  such that

$$\|W^B - \tilde{W}^B\|_{\diamond} \leq \varepsilon_B, \quad (14)$$

$$\overleftarrow{H}_{\min}(\tilde{W}^B) = H_{\min}^{\varepsilon_B}(W^B). \quad (15)$$

Denote  $P = W^B \times U_C, Q = \tilde{W}^B \times U_C$ , from inequality (14) we have

$$\begin{aligned}
\text{TD}(P, Q) &= \mathbb{E}_X \text{TD}(W^B(X), \tilde{W}^B(X)) \\
&\leq \max_{x \in \mathcal{X}} \text{TD}(W^B(x), \tilde{W}^B(x)) \\
&= \|W^B - \tilde{W}^B\|_{\diamond} \\
&\leq \varepsilon_B, \quad (16)
\end{aligned}$$

therefore,

$$\begin{aligned}
H_{\min}^{\varepsilon_B}(\mathbf{X}|\mathbf{Z})_{W^B \times U_C} &= \max_{P': \text{TD}(P, P') \leq \varepsilon_B} H_{\min}(\mathbf{X}|\mathbf{Z})_{P'} \\
&\geq H_{\min}(\mathbf{X}|\mathbf{Z})_{\tilde{W}^B \times U_C} \quad [\text{From inequality (16)}] \\
&= -\log \sum_{\mathbf{z} \in \mathcal{Z}^n} \max_{\mathbf{x} \in \mathcal{C}} \frac{1}{|\mathcal{C}|} \tilde{W}^B(\mathbf{z}|\mathbf{x}) \quad [\text{From equation (3)}] \\
&\geq -\log \frac{2^n}{|\mathcal{C}|} - \log \sum_{\mathbf{z} \in \mathcal{Z}^n} \max_{\mathbf{x} \in \mathcal{X}^n} \frac{1}{2^n} \tilde{W}^B(\mathbf{z}|\mathbf{x}) \\
&= -n + \log |\mathcal{C}| + H_{\min}(\tilde{W}^B) \quad [\text{From equation (6)}] \\
&= -n + \log |\mathcal{C}| + H_{\min}^{\varepsilon_B}(W^B). \quad [\text{From equation (15)}]
\end{aligned}$$

Combining the three steps and the channel condition  $H_{\min}^{\varepsilon_B}(W^B) \geq l_B$ , we get inequality (11).  $\square$

## 4.2 Binding

Before showing the binding property, we first establish a key lemma as follows (see Appendix A for the proof).

**Lemma 5.** *Let  $W$  be a BSC with transition probability  $p$  ( $p < \frac{1}{2}$ ). Assume that two binary sequences  $\mathbf{x}, \mathbf{y} \in \{0, 1\}^n$  are in the same type class  $T(q, 1 - q)$ , and their Hamming distance is  $d_H(\mathbf{x}, \mathbf{y}) = 2\sigma n$ . For any  $0 < \varepsilon < \frac{1}{2}(\frac{1}{2} - p)$ ,*

$$|\mathcal{T}_{W,\varepsilon}^n(\mathbf{x}) \cap \mathcal{T}_{W,\varepsilon}^n(\mathbf{y})| \leq \begin{cases} 4\varepsilon^2 n^4 2^{n[(1-2\sigma)h(\frac{p-\sigma+2\varepsilon}{1-2\sigma})+2\sigma]}, & \sigma \leq p + 2\varepsilon \\ 0, & \sigma > p + 2\varepsilon \end{cases} \quad (17)$$

The binding property is stated in Theorem 6.

**Theorem 6.** *When the code  $\mathcal{C}$  has constant weight and Hamming distance  $d = 2\sigma n$ , for the channel with condition  $\theta = (p, \varepsilon_A, l_A, \varepsilon_B, l_B)$ , the protocol  $\Phi[\varepsilon, \mathcal{C}, F]$  satisfies*

$$\delta_{b,\theta}(\Phi[\varepsilon, \mathcal{C}, F]) \leq \varepsilon_A + 4\varepsilon^2 n^4 2^{n[(1-2\sigma)h(\frac{p-\sigma+2\varepsilon}{1-2\sigma})+2\sigma]} - l_A. \quad (18)$$

*Proof.* A general commit strategy  $\mathcal{A}_C$  generates random variables  $(S, \underline{\mathbf{X}}, \overline{\mathbf{M}}, R)$  subjected to some joint distribution.  $R$  is the extra information flowing from  $\mathcal{A}_C$  to  $\mathcal{A}_{R0}$  and  $\mathcal{A}_{R1}$ . Similarly, a general reveal strategy is a probabilistic map  $(S, \underline{\mathbf{X}}, \overline{\mathbf{M}}, R) \mapsto (\mathbf{X}, M)$ . Specifically, we have

$$\begin{aligned} \mathcal{A}_{R0} &: (S, \underline{\mathbf{X}}, \overline{\mathbf{M}}, R) \mapsto (\mathbf{X}_0, M_0), \\ \mathcal{A}_{R1} &: (S, \underline{\mathbf{X}}, \overline{\mathbf{M}}, R) \mapsto (\mathbf{X}_1, M_1). \end{aligned}$$

The overall probability distribution of  $(S, \underline{\mathbf{X}}, \overline{\mathbf{M}}, \mathbf{X}_0, \mathbf{X}_1, M_0, M_1)$  after applying  $\mathcal{A}_C, \mathcal{A}_{R0}$  and  $\mathcal{A}_{R1}$  is denoted by  $P_{S, \underline{\mathbf{X}}, \overline{\mathbf{M}}, \mathbf{X}_0, \mathbf{X}_1, M_0, M_1}$ . Denote by  $\beta$  the test function that determines the acceptance in the reveal phase, then

$$\begin{aligned} & \delta_{b,\theta}(\Phi[\varepsilon, \mathcal{C}, F]) \\ &= \max_{P_{S, \underline{\mathbf{X}}, \overline{\mathbf{M}}, \mathbf{X}_0, \mathbf{X}_1, M_0, M_1}} \Pr_{(S, \underline{\mathbf{Z}}, \overline{\mathbf{M}}, \mathbf{X}_0, \mathbf{X}_1, M_0, M_1) \sim W^A \circ P_{S, \underline{\mathbf{X}}, \overline{\mathbf{M}}, \mathbf{X}_0, \mathbf{X}_1, M_0, M_1}} \left[ \begin{array}{l} M_0 \neq M_1 \wedge \\ F_1 = F_2 = \text{"acc"} \end{array} \right] \\ &\leq \max_{P_{S, \underline{\mathbf{X}}, \overline{\mathbf{M}}, \mathbf{X}_0, \mathbf{X}_1}} \max_{m_0 \neq m_1} \Pr_{(S, \underline{\mathbf{Z}}, \overline{\mathbf{M}}, \mathbf{X}_0, \mathbf{X}_1) \sim W^A \circ P_{S, \underline{\mathbf{X}}, \overline{\mathbf{M}}, \mathbf{X}_0, \mathbf{X}_1}} \left[ \begin{array}{l} \beta(S, \underline{\mathbf{Z}}, \overline{\mathbf{M}}, \mathbf{X}_0, m_0) = \text{"acc"} \wedge \\ \beta(S, \underline{\mathbf{Z}}, \overline{\mathbf{M}}, \mathbf{X}_1, m_1) = \text{"acc"} \end{array} \right] \\ &= \max_{P_{S, \underline{\mathbf{X}}, \overline{\mathbf{M}}, \mathbf{X}_0, \mathbf{X}_1, M_0, M_1}} \Pr \left[ \begin{array}{l} \mathbf{X}_0 \in \mathcal{C} \wedge f_S(\mathbf{X}_0) = m_0 + \overline{\mathbf{M}} \wedge \underline{\mathbf{Z}} \in \mathcal{T}_{W,\varepsilon}^n(\mathbf{X}_0) \wedge \\ \mathbf{X}_1 \in \mathcal{C} \wedge f_S(\mathbf{X}_1) = m_1 + \overline{\mathbf{M}} \wedge \underline{\mathbf{Z}} \in \mathcal{T}_{W,\varepsilon}^n(\mathbf{X}_1) \end{array} \right] \\ &\leq \max_{P_{S, \underline{\mathbf{X}}, \overline{\mathbf{M}}, \mathbf{X}_0, \mathbf{X}_1, M_0, M_1}} \Pr [\mathbf{X}_0, \mathbf{X}_1 \in \mathcal{C} \wedge \mathbf{X}_0 \neq \mathbf{X}_1 \wedge \underline{\mathbf{Z}} \in \mathcal{T}_{W,\varepsilon}^n(\mathbf{X}_0) \cap \mathcal{T}_{W,\varepsilon}^n(\mathbf{X}_1)] \\ &= \max_{P_{S, \underline{\mathbf{X}}, \overline{\mathbf{M}}, \mathbf{X}_0, \mathbf{X}_1, M_0, M_1}} \sum_{\substack{\mathbf{x}_0, \mathbf{x}_1 \in \mathcal{C} \\ \mathbf{x}_0 \neq \mathbf{x}_1}} P_{\mathbf{X}_0, \mathbf{X}_1}(\mathbf{x}_0, \mathbf{x}_1) \Pr_{\underline{\mathbf{Z}} \sim W^A \circ P_{\underline{\mathbf{X}} | (\mathbf{x}_0, \mathbf{x}_1) = (\mathbf{x}_0, \mathbf{x}_1)}} [\underline{\mathbf{Z}} \in \mathcal{T}_{W,\varepsilon}^n(\mathbf{x}_0) \cap \mathcal{T}_{W,\varepsilon}^n(\mathbf{x}_1)] \\ &\leq \max_{P_{\underline{\mathbf{X}}, \mathbf{x}_0, \mathbf{x}_1}} \max_{\substack{\mathbf{x}_0, \mathbf{x}_1 \in \mathcal{C} \\ \mathbf{x}_0 \neq \mathbf{x}_1}} \Pr_{\underline{\mathbf{Z}} \sim W^A \circ P_{\underline{\mathbf{X}} | \mathbf{x}_0, \mathbf{x}_1}} [\underline{\mathbf{Z}} \in \mathcal{T}_{W,\varepsilon}^n(\mathbf{x}_0) \cap \mathcal{T}_{W,\varepsilon}^n(\mathbf{x}_1)] \\ &\leq \max_{\substack{\mathbf{x}_0, \mathbf{x}_1 \in \mathcal{C} \\ \mathbf{x}_0 \neq \mathbf{x}_1}} \max_{P_{\underline{\mathbf{X}}}} \Pr_{\underline{\mathbf{Z}} \sim W^A \circ P_{\underline{\mathbf{X}}}} [\underline{\mathbf{Z}} \in \mathcal{T}_{W,\varepsilon}^n(\mathbf{x}_0) \cap \mathcal{T}_{W,\varepsilon}^n(\mathbf{x}_1)]. \quad (19) \end{aligned}$$

Because  $\forall \mathbf{x} \in \mathcal{X}^n, H_{\min}^{\varepsilon_A}(\underline{\mathbf{Z}})_{W^A(\mathbf{x})} \geq l_A$ , there exists a  $Q_{\underline{\mathbf{Z}}|\mathbf{x}} \in \Delta_{\leq}(\mathcal{Z}^n)$  for each  $\mathbf{x}$  such that  $H_{\min}(\underline{\mathbf{Z}})_{Q_{\underline{\mathbf{Z}}|\mathbf{x}}} \geq l_A$  and  $\text{TD}(Q_{\underline{\mathbf{Z}}|\mathbf{x}}, W^A(\mathbf{x})) \leq \varepsilon_A$ . Define

$$Q_{\underline{\mathbf{Z}}} = \sum_{\mathbf{x} \in \mathcal{X}^n} P_{\underline{\mathbf{X}}}(\mathbf{x}) Q_{\underline{\mathbf{Z}}|\mathbf{x}},$$

then we have

$$\begin{aligned} \text{TD}(Q_{\underline{\mathbf{Z}}}, W^A \circ P_{\underline{\mathbf{X}}}) &\leq \varepsilon_A, \\ H_{\min}(Q_{\underline{\mathbf{Z}}}) &\geq l_A. \end{aligned}$$



The probability in equation (19) is bounded by

$$\begin{aligned}
\Pr_{\mathbf{Z} \sim W^A \circ P_{\mathbf{X}}} [\mathbf{Z} \in \mathcal{T}_{W,\varepsilon}^n(\mathbf{x}_0) \cap \mathcal{T}_{W,\varepsilon}^n(\mathbf{x}_1)] &\leq \Pr_{\mathbf{Z} \sim Q_{\mathbf{Z}}} [\mathbf{Z} \in \mathcal{T}_{W,\varepsilon}^n(\mathbf{x}) \cap \mathcal{T}_{W,\varepsilon}^n(\mathbf{y})] + \varepsilon_A \\
&\leq |\mathcal{T}_{W,\varepsilon}^n(\mathbf{x}_0) \cap \mathcal{T}_{W,\varepsilon}^n(\mathbf{x}_1)| \max_{\mathbf{z}} Q_{\mathbf{Z}}(\mathbf{z}) + \varepsilon_A \\
&\leq 2^{-l_A} |\mathcal{T}_{W,\varepsilon}^n(\mathbf{x}_0) \cap \mathcal{T}_{W,\varepsilon}^n(\mathbf{x}_1)| + \varepsilon_A.
\end{aligned} \tag{20}$$

Combining inequalities (20), (19), and Lemma 5, we obtain (18).  $\square$

## 5 Asymptotic result

Define the function  $g_p : [0, p] \rightarrow [2p, h(p)]$  as

$$g_p(\sigma) = (1 - 2\sigma)h\left(\frac{p - \sigma}{1 - 2\sigma}\right) + 2\sigma.$$

$g_p$  is monotonically decreasing, thus we have a well-defined inverse function  $g_p^{-1}$ .

**Theorem 7.** *If the channel parameter sequence  $\{\theta_n\}$  with  $\theta_n := (p, \varepsilon_{A,n}, l_{A,n}, \varepsilon_{B,n}, l_{B,n})$  satisfies*

$$\lim_{n \rightarrow \infty} \varepsilon_{A,n} = \lim_{n \rightarrow \infty} \varepsilon_{B,n} = 0, \tag{21}$$

$$\lim_{n \rightarrow \infty} \frac{l_{A,n}}{n} = \xi_A \in [2p, h(p)], \tag{22}$$

$$\lim_{n \rightarrow \infty} \frac{l_{B,n}}{n} = \xi_B \in [0, h(p)], \tag{23}$$

then the following rate is achievable with  $\{\theta_n\}$ :

$$R = \max \{0, \xi_B - h(2g_p^{-1}(\xi_A))\}.$$

*Proof.* For a small real number  $\varepsilon'$ , we choose a protocol sequence  $\{\Phi_n[\varepsilon_n, \mathcal{C}_n, F_n]\}$  with the code sequence  $\{\mathcal{C}_n\}$  and a sequence of balanced UHF families  $\{F_n\}$ , where  $F_n = \{f_{s,n}\}_{s \in \mathcal{S}} : \mathcal{C}_n \rightarrow \mathcal{M}_n$ , satisfying the following conditions.

(I)  $\varepsilon_n = \frac{1}{\sqrt[3]{n}}$ .

(II)  $\mathcal{C}_n$  is a code with constant weight  $\lfloor n/2 \rfloor$  and Hamming distance  $2(g_p^{-1}(\xi_A) + \varepsilon')n$ .

(III)  $\log |\mathcal{C}_n| = (1 - h(2g_p^{-1}(\xi_A) + 2\varepsilon') - \varepsilon')n$ .

(IV)  $\log |\mathcal{M}_n| = (\xi_B - h(2g_p^{-1}(\xi_A) - 3\varepsilon') - \varepsilon')n$ .

Lemma 2 guarantees the existence of codes  $\{\mathcal{C}_n\}$  to satisfy (II) and (III) for large  $n$ .

Combining theorem 3 and the condition (I) we have

$$\lim_{n \rightarrow \infty} \delta_{c,\theta_n}(\Phi_n[\varepsilon_n, \mathcal{C}_n, F_n]) = \lim_{n \rightarrow \infty} 2^{-n\varepsilon_n^2} = 0.$$

To show  $\lim_{n \rightarrow \infty} \delta_{h,\theta_n}(\Phi[\varepsilon_n, \mathcal{C}_n, F_n]) = 0$ , we recall Theorem 4. It is sufficient to show that the part  $2^{\frac{1}{2}(\log |\mathcal{M}| + n - \log |\mathcal{C}| - l_B)}$  in Theorem 4 goes to zero. This fact can be shown as follows

$$\begin{aligned}
&\frac{\log |\mathcal{M}_n| + n - \log |\mathcal{C}_n| - l_{B,n}}{n} \\
&= (\xi_B - h(2g_p^{-1}(\xi_A)) - \varepsilon') + 1 - (1 - h(2g_p^{-1}(\xi_A) - 2\varepsilon') - \varepsilon') - \xi_B \\
&= h(2g_p^{-1}(\xi_A) - 2\varepsilon') - h(2g_p^{-1}(\xi_A) - 3\varepsilon') < 0.
\end{aligned}$$

To show  $\lim_{n \rightarrow \infty} \delta_{b,\theta_n}(\Phi[\varepsilon_n, \mathcal{C}_n, F_n]) = 0$ , we recall Theorem 6. Because of condition (II), we have  $\sigma = g_p^{-1}(\xi_A) + \varepsilon'$ . It is sufficient to show that the part  $2^{n[(1-2\sigma)h(\frac{p-\sigma+2\varepsilon}{1-2\sigma})+2\sigma]-l_{A,n}}$  exponentially goes

to zero. This fact can be shown as follows

$$\begin{aligned}
& \lim_{n \rightarrow \infty} (1 - 2\sigma)h \left( \frac{p - \sigma + 2\varepsilon_n}{1 - 2\sigma} \right) + 2\sigma - \frac{l_{A,n}}{n} \\
&= (1 - 2\sigma)h \left( \frac{p - \sigma}{1 - 2\sigma} \right) + 2\sigma - g_p(\sigma - \varepsilon') \\
&= g_p(\sigma) - g_p(\sigma - \varepsilon') < 0.
\end{aligned}$$

Condition (IV) implies that, for any  $R' < R$ , there exists an  $\varepsilon' > 0$  such that  $\log |\mathcal{M}_n|/n \rightarrow R'$ , which concludes the proof.  $\square$

Figure 2 is a numeric illustration of the asymptotic rate versus channel parameters when the channel parameter sequence  $\{\theta_n\}$  satisfies (21), (22), (23) and  $p = 0.1$ . Commitment becomes impossible when  $\xi_A \lesssim 0.82h(p)$  or  $\xi_B = 0$ . It is clear that the rate bears higher tolerance on channel  $W^B$  than  $W^A$ .

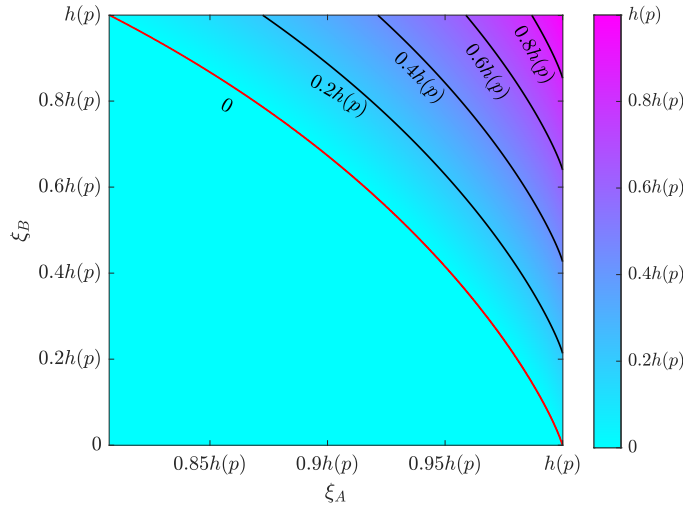

Figure 2: The rate as a function of  $\xi_A$  and  $\xi_B$  when  $p = 0.1$  ( $h(p) \approx 0.469$ ). The X and Y axes are  $\xi_A$  and  $\xi_B$  respectively. The rate hits zero at the red line and below, and hits maximum value  $h(p)$  at the point  $\xi_A = \xi_B = h(p)$ .

Theorem 7 provides a commitment rate for general channels  $W^A$  and  $W^B$ . In the special case when  $W^A$  and  $W^B$  are fixed as i.i.d. BSC, we demonstrate that Theorem 7 recovers the earlier result of [WNI03, CDN20]. To establish this connection, we first introduce Lemma 8, which examines the asymptotic behaviour of i.i.d. BSC.

**Lemma 8.** *For  $n$ -fold BSC  $W^n : \{0, 1\}^n \rightarrow \{0, 1\}^n$  with transition probability  $p$ , there exist parameters  $\mu_n, l_n(p)$  such that*

$$\begin{aligned}
H_{\min}^{\mu_n}(\mathbf{Z})_{W^n(\mathbf{x})} &\geq l_n(p) \text{ for all } \mathbf{x} \in \{0, 1\}^n, \\
\overleftarrow{H}_{\min}^{\mu_n}(W^n) &\geq l_n(p),
\end{aligned}$$

and

$$\begin{aligned}
\lim_{n \rightarrow \infty} \mu_n &= 0, \\
\lim_{n \rightarrow \infty} \frac{l_n(p)}{n} &= h(p).
\end{aligned}$$

**Corollary 9.** *If  $W^n, W^A$  and  $W^B$  are  $n$ -fold BSC with transition probability  $p, p_A$  and  $p_B$  respectively, then the following commitment rate is achievable with Protocol 1:*

$$R = \max \{0, h(p_B) - h(2g_p^{-1}(h(p_A)))\}. \quad (24)$$

*Proof.* According to Lemma 8, the parameter  $\theta_n = (p, \varepsilon_{A,n}, l_{A,n}, \varepsilon_{B,n}, l_{B,n})$  can be taken as  $\varepsilon_{A,n} = \varepsilon_{B,n} = \mu_n, l_{A,n} = l_n(p_A), l_{B,n} = l_n(p_B)$ . The rate in equation (24) follows immediately from Theorem 7.  $\square$

Crépeau et al. [CDN20] consider the case  $p_A = p_B \leq p$ , as in Corollary 9, and derive the capacity

$$C = h(p_A) - h\left(\frac{p - p_A}{1 - 2p_A}\right). \quad (25)$$

When  $p_A = p_B < p$ , denote  $p' = \frac{p - p_A}{1 - 2p_A}$ , then the following argument shows that the capacity  $C$  exceeds the rate  $R$  presented in equation (24):

$$\begin{aligned} h(p_A) &= h\left(\frac{p - p'}{1 - 2p'}\right) < g_p(p') < g_p\left(\frac{p'}{2}\right) \\ \implies 2g_p^{-1}(h(p_A)) &> p' \\ \implies h(2g_p^{-1}(h(p_A))) &> h(p'). \end{aligned}$$

This gap is expected because the rate  $R$  is derived by assuming  $W^A$  and  $W^B$  are unstructured, while the capacity  $C$  adopts a fixed i.i.d. channel model. When  $p_A = p_B = p$ , we have  $g_p^{-1}(h(p_A)) = 0$ , so both  $R$  and  $C$  reduce to the previously established capacity  $h(p)$  in [WNI03, IMNW04], indicating consistency with earlier findings.

## 6 Conclusion

We have constructed a string commitment protocol over a noisy channel. The proposed protocol correctly reveals the message when the channel is an  $n$ -fold BSC  $W^n$ , which is called the completeness condition. When dishonest Bob manipulates the channel to be a general channel  $W^B$  to satisfy the condition  $\overleftarrow{H}_{\min}^{\varepsilon_B}(W^B) \geq l_B$ , he gets no information about the message before the reveal phase, which is called the hiding condition. When dishonest Alice manipulates the channel to be a general channel to satisfy the condition  $\forall \mathbf{x} \in \mathcal{X}^n, H_{\min}^{\varepsilon_A}(\mathbf{Z}|\mathbf{X} = \mathbf{x}) \geq l_A$ , she cannot find two distinct messages that honest Bob can accept both at the reveal phase. Also, we have derived the commitment rate under the condition in Theorem 7, which is determined by the channel noise parameter  $p$  with honest Alice and honest Bob, the Hamming distance of our code, the asymptotic ratios  $\xi_A$  and  $\xi_B$  of the lower bounds  $l_A, l_B$  to  $n$  under dishonest Alice and dishonest Bob respectively. Our commitment rate coincides with the commitment capacity in earlier results [WNI03, IMNW04] when the channel  $W^A$  and  $W^B$  are fixed as  $n$ -fold BSC.

Although we assume an  $n$ -fold BSC when Alice and Bob are honest, this assumption is not necessary for the completeness condition. Instead, Lemma 5 ensures the acceptance condition is met for the conditional typical set corresponding to BSC. This formulation restricts the honest channel to a BSC. If Lemma 5 can be relaxed to a general discrete memoryless channel, then the assumption on the honest channel can be generalized accordingly. This extension is an interesting future study.

## 7 Acknowledgement

JW and MT are supported by the National Research Foundation, Singapore and A\*STAR under its Quantum Engineering Programme (NRF2021-QEP2-01-P06). MH is supported in part by the National Natural Science Foundation of China (Grant No. 62171212).

## References

- [BBCM95] Charles H Bennett, Gilles Brassard, Claude Crépeau, and Ueli M Maurer. Generalized privacy amplification. *IEEE Transactions on Information Theory*, 41(6):1915–1923, 1995.
- [BCC88] Gilles Brassard, David Chaum, and Claude Crépeau. Minimum disclosure proofs of knowledge. *Journal of Computer and System Sciences*, 37(2):156–189, October 1988.

- [Blu83] Manuel Blum. Coin flipping by telephone a protocol for solving impossible problems. *ACM SIGACT News*, 15(1):23–27, January 1983.
- [BOCG<sup>+</sup>06] Michael Ben-Or, Claude Crépeau, Daniel Gottesman, Avinatan Hassidim, and Adam Smith. Secure Multiparty Quantum Computation with (Only) a Strict Honest Majority. In *2006 47th Annual IEEE Symposium on Foundations of Computer Science (FOCS'06)*, pages 249–260, October 2006.
- [CDLR16] Ignacio Cascudo, Ivan Damgård, Felipe Lacerda, and Samuel Ranellucci. Oblivious Transfer from Any Non-trivial Elastic Noisy Channel via Secret Key Agreement. In Martin Hirt and Adam Smith, editors, *Theory of Cryptography*, pages 204–234, Berlin, Heidelberg, 2016. Springer.
- [CDN20] Claude Crépeau, Rafael Dowsley, and Anderson C. A. Nascimento. On the Commitment Capacity of Unfair Noisy Channels. *IEEE Transactions on Information Theory*, 66(6):3745–3752, June 2020.
- [CK78] I. Csiszár and J. Körner. Broadcast channels with confidential messages. *IEEE Transactions on Information Theory*, 24(3):339–348, 1978.
- [CK12] Sarah Croke and Adrian Kent. Security details for bit commitment by transmitting measurement outcomes. *Phys. Rev. A*, 86:052309, Nov 2012.
- [CMW05] Claude Crépeau, Kirill Morozov, and Stefan Wolf. Efficient Unconditional Oblivious Transfer from Almost Any Noisy Channel. In Carlo Blundo and Stelvio Cimato, editors, *Security in Communication Networks*, Lecture Notes in Computer Science, pages 47–59, Berlin, Heidelberg, 2005. Springer.
- [Cré97] Claude Crépeau. Efficient Cryptographic Protocols Based on Noisy Channels. In Walter Fumy, editor, *Advances in Cryptology — EUROCRYPT '97*, Lecture Notes in Computer Science, pages 306–317, Berlin, Heidelberg, 1997. Springer.
- [CW79] J. Lawrence Carter and Mark N. Wegman. Universal classes of hash functions. *Journal of Computer and System Sciences*, 18(2):143–154, 1979.
- [DKS99] Ivan Damgård, Joe Kilian, and Louis Salvail. On the (Im)possibility of Basing Oblivious Transfer and Bit Commitment on Weakened Security Assumptions. In Jacques Stern, editor, *Advances in Cryptology — EUROCRYPT '99*, Lecture Notes in Computer Science, pages 56–73, Berlin, Heidelberg, 1999. Springer.
- [DM13] Grégory Demay and Ueli Maurer. Unfair coin tossing. In *2013 IEEE International Symposium on Information Theory*, pages 1556–1560, July 2013.
- [DN17] Rafael Dowsley and Anderson C. A. Nascimento. On the Oblivious Transfer Capacity of Generalized Erasure Channels Against Malicious Adversaries: The Case of Low Erasure Probability. *IEEE Transactions on Information Theory*, 63(10):6819–6826, October 2017.
- [DNS10] Frédéric Dupuis, Jesper Buus Nielsen, and Louis Salvail. Secure Two-Party Quantum Evaluation of Unitaries against Specious Adversaries. In Tal Rabin, editor, *Advances in Cryptology – CRYPTO 2010*, Lecture Notes in Computer Science, pages 685–706, Berlin, Heidelberg, 2010. Springer.
- [GMW91] Oded Goldreich, Silvio Micali, and Avi Wigderson. Proofs that yield nothing but their validity or all languages in NP have zero-knowledge proof systems. *J. ACM*, 38(3):690–728, July 1991.
- [GMW19] Oded Goldreich, Silvio Micali, and Avi Wigderson. How to play any mental game, or a completeness theorem for protocols with honest majority. In *Providing Sound Foundations for Cryptography: On the Work of Shafi Goldwasser and Silvio Micali*, pages 307–328. Association for Computing Machinery, New York, NY, USA, October 2019.

- [HILL99] Johan HÅstad, Russell Impagliazzo, Leonid A. Levin, and Michael Luby. A Pseudorandom Generator from any One-way Function. *SIAM Journal on Computing*, 28(4):1364–1396, January 1999.
- [HW22] Masahito Hayashi and Naqeeb Ahmad Warsi. Commitment capacity of classical-quantum channels. In *2022 IEEE International Symposium on Information Theory (ISIT)*, pages 1058–1063, June 2022.
- [HW23] Masahito Hayashi and Naqeeb Ahmad Warsi. Commitment Capacity of Classical-Quantum Channels. *IEEE Transactions on Information Theory*, 69(8):5083–5099, August 2023.
- [IKO<sup>+</sup>11] Yuval Ishai, Eyal Kushilevitz, Rafail Ostrovsky, Manoj Prabhakaran, Amit Sahai, and Jürg Wullschlegler. Constant-Rate Oblivious Transfer from Noisy Channels. In Phillip Rogaway, editor, *Advances in Cryptology – CRYPTO 2011*, Lecture Notes in Computer Science, pages 667–684, Berlin, Heidelberg, 2011. Springer.
- [IMANW06] Hideki Imai, Kirill Morozov, Anderson C. A. Nascimento, and Andreas Winter. Efficient Protocols Achieving the Commitment Capacity of Noisy Correlations. In *2006 IEEE International Symposium on Information Theory*, pages 1432–1436, July 2006.
- [IMNW04] H. Imai, J. Muller-Quade, A. Nascimento, and A. Winter. Rates for bit commitment and coin tossing from noisy correlation. In *International Symposium on Information Theory, 2004. ISIT 2004. Proceedings.*, pages 45–, June 2004.
- [Ken99] Adrian Kent. Unconditionally secure bit commitment. *Phys. Rev. Lett.*, 83:1447–1450, Aug 1999.
- [KMS16] Dakshita Khurana, Hemanta K. Maji, and Amit Sahai. Secure Computation from Elastic Noisy Channels. In Marc Fischlin and Jean-Sébastien Coron, editors, *Advances in Cryptology – EUROCRYPT 2016*, pages 184–212, Berlin, Heidelberg, 2016. Springer.
- [KTHW13] Jędrzej Kaniewski, Marco Tomamichel, Esther Hänggi, and Stephanie Wehner. Secure bit commitment from relativistic constraints. *IEEE Transactions on Information Theory*, 59(7):4687–4699, 2013.
- [LC97] Hoi-Kwong Lo and H. F. Chau. Is Quantum Bit Commitment Really Possible? *Physical Review Letters*, 78(17):3410–3413, April 1997.
- [LC98] Hoi-Kwong Lo and H. F. Chau. Why quantum bit commitment and ideal quantum coin tossing are impossible. *Physica D: Nonlinear Phenomena*, 120(1):177–187, September 1998.
- [Lev71] Vladimir Iosifovich Levenshtein. Upper-bound estimates for fixed-weight codes. *Problemy Peredachi Informatsii*, 7(4):3–12, 1971.
- [LKB<sup>+</sup>13] T. Lunghi, J. Kaniewski, F. Bussi eres, R. Houlmann, M. Tomamichel, A. Kent, N. Gisin, S. Wehner, and H. Zbinden. Experimental bit commitment based on quantum communication and special relativity. *Phys. Rev. Lett.*, 111:180504, Nov 2013.
- [LKB<sup>+</sup>15] T. Lunghi, J. Kaniewski, F. Bussi eres, R. Houlmann, M. Tomamichel, S. Wehner, and H. Zbinden. Practical relativistic bit commitment. *Phys. Rev. Lett.*, 115:030502, Jul 2015.
- [May97] Dominic Mayers. Unconditionally Secure Quantum Bit Commitment is Impossible. *Physical Review Letters*, 78(17):3414–3417, April 1997.
- [Ren08] Renato Renner. Security of quantum key distribution. *International Journal of Quantum Information*, 06(01):1–127, 2008.
- [Sam01] Alex Samorodnitsky. On the Optimum of Delsarte’s Linear Program. *Journal of Combinatorial Theory, Series A*, 96(2):261–287, November 2001.

- [Tom15] Marco Tomamichel. *Quantum information processing with finite resources: mathematical foundations*. Springer Cham, 2015.
- [Wil13] Mark M Wilde. *Quantum information theory*. Cambridge university press, 2013.
- [WNI03] Andreas Winter, Anderson C. A. Nascimento, and Hideki Imai. Commitment Capacity of Discrete Memoryless Channels. In Kenneth G. Paterson, editor, *Cryptography and Coding*, Lecture Notes in Computer Science, pages 35–51, Berlin, Heidelberg, 2003. Springer.
- [WTHR11] Severin Winkler, Marco Tomamichel, Stefan Hengl, and Renato Renner. Impossibility of growing quantum bit commitments. *Phys. Rev. Lett.*, 107:090502, Aug 2011.
- [Wyn75] A. D. Wyner. The Wire-Tap Channel. *Bell System Technical Journal*, 54(8):1355–1387, 1975.

## A Proof of Lemma 5

**Lemma.** Let  $W$  be a BSC with transition probability  $p$  ( $p < \frac{1}{2}$ ). Assume that two binary sequences  $\mathbf{x}, \mathbf{y} \in \{0, 1\}^n$  are in the same type class  $T(q, 1 - q)$ , and their Hamming distance is  $d_H(\mathbf{x}, \mathbf{y}) = 2\sigma n$ . For any  $0 < \varepsilon < \frac{1}{2}(\frac{1}{2} - p)$ ,

$$|\mathcal{T}_{W,\varepsilon}^n(\mathbf{x}) \cap \mathcal{T}_{W,\varepsilon}^n(\mathbf{y})| \leq \begin{cases} 4\varepsilon^2 n^4 2^{n[(1-2\sigma)h(\frac{p-\sigma+2\varepsilon}{1-2\sigma})+2\sigma]}, & \text{if } \sigma \leq p + 2\varepsilon \\ 0, & \text{if } \sigma > p + 2\varepsilon \end{cases} \quad (26)$$

*Proof.* We will prove the lemma in three steps.

**Step 1:** Preparation.

For fixed  $\mathbf{x}, \mathbf{y} \in \{0, 1\}^n$ , divide the  $n$  positions into the following sectors:

$$\mathcal{I}_{i,j} := \{k \in [n] \mid x_k = i, y_k = j\} \text{ for } i, j = 0, 1,$$

where  $[n] = \{1, 2, \dots, n\}$ . Denote the size of the sector  $|\mathcal{I}_{ij}|$  by  $\sigma_{ij}n$ . Obviously,  $\sum_{i,j} \sigma_{ij} = 1$ . Because  $\mathbf{x}, \mathbf{y}$  are in the type class  $T(q, 1 - q)$ , we have

$$\sigma_{01} + \sigma_{00} = \sigma_{10} + \sigma_{00} = q, \text{ i.e., } \sigma_{01} = \sigma_{10}.$$

Note that  $d_H(\mathbf{x}, \mathbf{y})/n = (\sigma_{01} + \sigma_{10}) = 2\sigma$ , therefore,

$$\begin{aligned} \sigma_{01} &= \sigma_{10} = \sigma, \\ \sigma_{00} &= q - \sigma, \sigma_{11} = 1 - q - \sigma. \end{aligned}$$

For any sequence  $\mathbf{z} \in \{0, 1\}^n$  and sector  $\mathcal{I} \subseteq [n]$ , define the following weight function, which counts the number of 1s at position  $\mathcal{I}$ .

$$\text{wt}_{\mathcal{I}}(\mathbf{z}) := \sum_{x \in \mathcal{I}} z_x.$$

Consider a tuple  $\vec{b} = (b_{00}, b_{01}, b_{11}, b_{10}) \in \mathbb{N}^4$ . If  $\vec{b} \in [0, \sigma_{00}n] \times [0, \sigma_{01}n] \times [0, \sigma_{11}n] \times [0, \sigma_{10}n]$ ,  $\vec{b}$  actually defines a class in  $\{0, 1\}^n$ :

$$G(\vec{b}) := \{\mathbf{z} \in \{0, 1\}^n \mid \forall (i, j) \in \{0, 1\}^2, \text{wt}_{\mathcal{I}_{ij}}(\mathbf{z}) = b_{ij}\},$$

Define the set

$$\begin{aligned} \Lambda := & \left\{ \vec{b} \in \mathbb{N}^4 \mid \frac{\vec{b}}{n} \in [0, \sigma_{00}] \times [0, \sigma_{01}] \times [0, \sigma_{11}] \times [0, \sigma_{10}] \wedge \right. \\ & \frac{1}{n}(b_{00} + b_{01}) \in [pq - \varepsilon, pq + \varepsilon] \wedge \\ & \frac{1}{n}(b_{11} + b_{10}) \in [(1-p)(1-q) - \varepsilon, (1-p)(1-q) + \varepsilon] \wedge \\ & \frac{1}{n}(b_{00} + b_{10}) \in [pq - \varepsilon, pq + \varepsilon] \wedge \\ & \left. \frac{1}{n}(b_{11} + b_{01}) \in [(1-p)(1-q) - \varepsilon, (1-p)(1-q) + \varepsilon] \right\}, \end{aligned}$$

and its continuous version

$$\begin{aligned}
\Lambda' &:= \{\vec{a} \in [0, \sigma_{00}] \times [0, \sigma_{01}] \times [0, \sigma_{11}] \times [0, \sigma_{10}]\} \\
& a_{00} + a_{01} \in [pq - \varepsilon, pq + \varepsilon] \wedge \\
& a_{11} + a_{10} \in [(1-p)(1-q) - \varepsilon, (1-p)(1-q) + \varepsilon] \wedge \\
& a_{00} + a_{10} \in [pq - \varepsilon, pq + \varepsilon] \wedge \\
& a_{11} + a_{01} \in [(1-p)(1-q) - \varepsilon, (1-p)(1-q) + \varepsilon]\},
\end{aligned}$$

where  $\vec{a} = (a_{00}, a_{01}, a_{10}, a_{11})$ . The empirical distribution  $P_{\mathbf{x}, \mathbf{z}}(x, z)$  can be expressed as

$$\begin{aligned}
P_{\mathbf{x}, \mathbf{z}}(0, 0) &= q - \frac{1}{n} (\text{wt}_{\mathcal{I}_{00}}(\mathbf{z}) + \text{wt}_{\mathcal{I}_{01}}(\mathbf{z})), \\
P_{\mathbf{x}, \mathbf{z}}(0, 1) &= \frac{1}{n} (\text{wt}_{\mathcal{I}_{00}}(\mathbf{z}) + \text{wt}_{\mathcal{I}_{01}}(\mathbf{z})), \\
P_{\mathbf{x}, \mathbf{z}}(1, 0) &= 1 - q - \frac{1}{n} (\text{wt}_{\mathcal{I}_{10}}(\mathbf{z}) + \text{wt}_{\mathcal{I}_{11}}(\mathbf{z})), \\
P_{\mathbf{x}, \mathbf{z}}(1, 1) &= \frac{1}{n} (\text{wt}_{\mathcal{I}_{10}}(\mathbf{z}) + \text{wt}_{\mathcal{I}_{11}}(\mathbf{z})).
\end{aligned}$$

Now we expand the definition of  $\mathcal{T}_{W, \varepsilon}^n(\mathbf{x})$  in equation (8).

$$\begin{aligned}
\mathbf{z} \in \mathcal{T}_{W, \varepsilon}^n(\mathbf{x}) &\implies \forall (x, z) \in \{0, 1\}^2, |P_{\mathbf{x}, \mathbf{z}}(x, z) - W(z|x)P_{\mathbf{x}}(x)| \leq \varepsilon. \\
&\implies \left| \frac{1}{n} (\text{wt}_{\mathcal{I}_{00}}(\mathbf{z}) + \text{wt}_{\mathcal{I}_{01}}(\mathbf{z})) - pq \right| \leq \varepsilon \quad \wedge \\
&\left| \frac{1}{n} (\text{wt}_{\mathcal{I}_{10}}(\mathbf{z}) + \text{wt}_{\mathcal{I}_{11}}(\mathbf{z})) - (1-p)(1-q) \right| \leq \varepsilon
\end{aligned}$$

Similarly, for  $\mathcal{T}_{W, \varepsilon}^n(\mathbf{y})$ , we have

$$\begin{aligned}
\mathbf{z} \in \mathcal{T}_{W, \varepsilon}^n(\mathbf{y}) &\implies \left| \frac{1}{n} (\text{wt}_{\mathcal{I}_{00}}(\mathbf{z}) + \text{wt}_{\mathcal{I}_{10}}(\mathbf{z})) - pq \right| \leq \varepsilon \quad \wedge \\
&\left| \frac{1}{n} (\text{wt}_{\mathcal{I}_{11}}(\mathbf{z}) + \text{wt}_{\mathcal{I}_{01}}(\mathbf{z})) - (1-p)(1-q) \right| \leq \varepsilon.
\end{aligned}$$

Note that  $\text{wt}_{\mathcal{I}_{ij}}(\mathbf{z})/n \in [0, \sigma_{ij}]$  holds for any  $(i, j) \in \{0, 1\}^2$ . Therefore,

$$\mathbf{z} \in \mathcal{T}_{W, \varepsilon}^n(\mathbf{x}) \cap \mathcal{T}_{W, \varepsilon}^n(\mathbf{y}) \implies \mathbf{z} \in \bigcup_{\vec{b} \in \Lambda} G(\vec{b}).$$

**Step 2:** Transform the estimation of  $|\mathcal{T}_{W, \varepsilon}^n(\mathbf{x}) \cap \mathcal{T}_{W, \varepsilon}^n(\mathbf{y})|$  into an optimization problem. With the above notations, the target quantity can be re-written as

$$|\mathcal{T}_{W, \varepsilon}^n(\mathbf{x}) \cap \mathcal{T}_{W, \varepsilon}^n(\mathbf{y})| \leq \left| \bigcup_{\vec{b} \in \Lambda} G(\vec{b}) \right| \leq |\Lambda| \cdot \max_{\vec{b} \in \Lambda} |G(\vec{b})|. \tag{27}$$

Note that  $\Lambda = \emptyset$  if  $\sigma > p + 2\varepsilon$ , thus the second case of inequality (26) is obtained.

If  $\sigma \leq p + 2\varepsilon$ , we first estimate the first term of (27):

$$\begin{aligned}
|\Lambda| &\leq \left| \{(b_{00}, b_{01}) \in \mathbb{N}^2 \mid b_{00} + b_{01} \in [pq - \varepsilon, pq + \varepsilon]\} \times \right. \\
&\quad \left. \{(b_{10}, b_{11}) \in \mathbb{N}^2 \mid b_{10} + b_{11} \in [(1-p)(1-q) - \varepsilon, (1-p)(1-q) + \varepsilon]\} \right| \\
&\leq (pqn + 1)(2\varepsilon n + 1) \cdot ((1-p)(1-q)n + 1)(2\varepsilon n + 1) \tag{28} \\
&\leq 4\varepsilon^2 n^4. \tag{29}
\end{aligned}$$

where inequality (28) follows by estimating the number of lattice points in 2-dimensional region with the area. To estimate the second term of (27), we have

$$\begin{aligned} \max_{\vec{b} \in \Lambda} |G(\vec{b})| &= \max_{\vec{b} \in \Lambda} \prod_{i,j=0,1} \binom{\sigma_{ij}n}{b_{ij}} \\ &\leq \max_{\vec{b} \in \{n\vec{a} \mid \vec{a} \in \Lambda'\}} \prod_{i,j=0,1} \binom{\sigma_{ij}n}{b_{ij}} \end{aligned} \quad (30)$$

$$\begin{aligned} &= \max_{\vec{a} \in \Lambda'} \prod_{i,j=0,1} \binom{\sigma_{ij}n}{a_{ij}n} \\ &\leq \max_{\vec{a} \in \Lambda'} \prod_{i,j=0,1} 2^{n\sigma_{ij}h(\frac{a_{ij}}{\sigma_{ij}})} \end{aligned} \quad (31)$$

$$= 2^{n \max_{\vec{a} \in \Lambda'} [\sum_{i,j=0,1} \sigma_{ij}h(\frac{a_{ij}}{\sigma_{ij}})]}, \quad (32)$$

where inequality (30) holds because  $\Lambda \subseteq \{n\vec{a} \mid \vec{a} \in \Lambda'\}$ , and inequality (31) follows from the property of binomial coefficient.

**Step 3:** Estimate the exponent term of (32).

Denote the following intervals:

$$\begin{aligned} I &= [\max\{0, \sigma - p(1-q) - \varepsilon, \sigma - (1-p)q - \varepsilon\}, \min\{\sigma, pq + \varepsilon, (1-p)(1-q) + \varepsilon\}], \\ \Lambda'(a_{01}) &= [pq - a_{01} - \varepsilon, pq - a_{01} + \varepsilon] \times [(1-p)(1-q) - a_{01} - \varepsilon, (1-p)(1-q) - a_{01} + \varepsilon] \\ &\quad \times [a_{01} - 2\varepsilon, a_{01} + 2\varepsilon]. \end{aligned}$$

Then it can be verified that

$$\Lambda' \subseteq \{\vec{a} \mid a_{01} \in I, (a_{00}, a_{11}, a_{10}) \in \Lambda'(a_{01})\}. \quad (33)$$

The exponent term of (32) is written as

$$\begin{aligned} &\max_{\vec{a} \in \Lambda'} \sum_{i,j=0,1} \sigma_{ij}h\left(\frac{a_{ij}}{\sigma_{ij}}\right) \\ &\leq \max_{a_{01} \in I} \max_{(a_{00}, a_{11}, a_{10}) \in \Lambda'(a_{01})} (q - \sigma)h\left(\frac{a_{00}}{q - \sigma}\right) + \sigma h\left(\frac{a_{01}}{\sigma}\right) + (1 - q - \sigma)h\left(\frac{a_{11}}{1 - q - \sigma}\right) + \sigma h\left(\frac{a_{10}}{\sigma}\right) \end{aligned} \quad (34)$$

$$\leq \max_{a_{01} \in I} \max_{(a_{00}, a_{11}, a_{10}) \in \Lambda'(a_{01})} (q - \sigma)h\left(\frac{a_{00}}{q - \sigma}\right) + (1 - q - \sigma)h\left(\frac{a_{11}}{1 - q - \sigma}\right) + 2\sigma, \quad (35)$$

where inequality (34) follows from equation (33). Define the function  $f$  as

$$f(x) := (q - \sigma) \max_{y_1 \in I_1(x)} h(y_1) + (1 - q - \sigma) \max_{y_2 \in I_2(x)} h(y_2) + 2\sigma.$$

where  $I_1(x) = \left[\frac{pq-x-\varepsilon}{q-\sigma}, \frac{pq-x+\varepsilon}{q-\sigma}\right]$ ,  $I_2 = \left[\frac{(1-p)(1-q)-x-\varepsilon}{1-q-\sigma}, \frac{(1-p)(1-q)-x+\varepsilon}{1-q-\sigma}\right]$ . By replacing  $x, y_1$  and  $y_2$  with  $a_{01}, \frac{a_{00}}{q-\sigma}$  and  $\frac{a_{11}}{1-q-\sigma}$ , we observe that the expression (35) is equal to  $\max_{x \in I} f(x)$ . Note that:

- If  $x \in [-q(\frac{1}{2} - p) + \frac{\sigma}{2} - \varepsilon, -q(\frac{1}{2} - p) + \frac{\sigma}{2} + \varepsilon]$ , then  $\max_{y_1 \in I_1(x)} h(y_1) = 1$ ;
- If  $x \in [(1-q)(\frac{1}{2} - p) + \frac{\sigma}{2} - \varepsilon, -q(\frac{1}{2} - p) + \frac{\sigma}{2} + \varepsilon]$ , then  $\max_{y_2 \in I_2(x)} h(y_2) = 1$ .

Because  $\varepsilon < \frac{1}{2}(\frac{1}{2} - p)$ , the latter interval is strictly larger than the former. Therefore,  $f(x)$  reaches maximum only when  $x \in [-q(\frac{1}{2} - p) + \frac{\sigma}{2} + \varepsilon, (1-q)(\frac{1}{2} - p) + \frac{\sigma}{2} - \varepsilon]$ . Then for  $x$  in this interval,

$$\max_{y_1 \in I_1(x)} h(y_1) = h\left(\frac{pq - x + \varepsilon}{q - \sigma}\right), \quad (36)$$

$$\max_{y_2 \in I_2(x)} h(y_2) = h\left(\frac{(1-p)(1-q) - x - \varepsilon}{1 - q - \sigma}\right). \quad (37)$$



Thus we have

$$\begin{aligned}
\max_{x \in I} f(x) &= \max_{x \in [-q(\frac{1}{2}-p) + \frac{\sigma}{2} + \varepsilon, (1-q)(\frac{1}{2}-p) + \frac{\sigma}{2} - \varepsilon]} (q - \sigma)h\left(\frac{pq - x + \varepsilon}{q - \sigma}\right) \\
&\quad + (1 - q - \sigma)h\left(\frac{(1-p)(1-q) - x - \varepsilon}{1 - q - \sigma}\right) + 2\sigma \\
&= (1 - 2\sigma)h\left(\frac{p - \sigma + 2\varepsilon}{1 - 2\sigma}\right) + 2\sigma.
\end{aligned} \tag{38}$$

Combining inequalities (32), (35) and (38), we get the inequality

$$\max_{\vec{b} \in \Lambda} |G(\vec{b})| \leq 2^n [(1-2\sigma)h(\frac{p-\sigma+2\varepsilon}{1-2\sigma}) + 2\sigma]. \tag{39}$$

Combining inequalities (27), (29) and (39), the first case of inequality (26) is obtained.  $\square$

## B Proof of Lemma 8

**Lemma.** For  $n$ -fold BSC  $W^n : \{0, 1\}^n \rightarrow \{0, 1\}^n$  with transition probability  $p$ , there exist parameters  $\mu_n, l_n(p)$  such that

$$H_{\min}^{\mu_n}(\mathbf{Z})_{W^n(\mathbf{x})} \geq l_n(p) \text{ for all } \mathbf{x} \in \{0, 1\}^n, \tag{40}$$

$$\overleftarrow{H}_{\min}^{\mu_n}(W^n) \geq l_n(p), \tag{41}$$

and

$$\lim_{n \rightarrow \infty} \mu_n = 0, \tag{42}$$

$$\lim_{n \rightarrow \infty} \frac{l_n(p)}{n} = h(p). \tag{43}$$

*Proof.* We will prove the lemma in three steps.

**Step 1:** Set values of  $\mu_n$  and  $l_n(p)$ .

Take  $\varepsilon = n^{-1/3}$ ,  $\mu_n = 4 \cdot 2^{-\sqrt[3]{n}}$ ,  $l_n(p) = n(h(p) - c\varepsilon)$ , where  $c = 2 \log(p(1-p))$  is a constant. Then equation (42) and (43) are obvious.

**Step 2:** Prove inequality (40) for any fixed  $\mathbf{x} \in \{0, 1\}^n$ .

By Lemma 1, we have

$$\Pr_{\mathbf{Z} \sim W^n(\mathbf{x})} [\mathbf{Z} \in \mathcal{T}_{W, \varepsilon}^n(\mathbf{x})] = \sum_{\mathbf{z} \in \mathcal{T}_{W, \varepsilon}^n(\mathbf{x})} W^n(\mathbf{z}|\mathbf{x}) \geq 1 - \mu_n. \tag{44}$$

Let  $Q_{\mathbf{Z}}$  be a subnormalized distribution on  $\{0, 1\}^n$  satisfying

$$Q_{\mathbf{Z}}(\mathbf{z}) = \begin{cases} 0, & \text{if } \mathbf{z} \notin \mathcal{T}_{W, \varepsilon}^n(\mathbf{x}) \\ W^n(\mathbf{z}|\mathbf{x}), & \text{if } \mathbf{z} \in \mathcal{T}_{W, \varepsilon}^n(\mathbf{x}) \end{cases}. \tag{45}$$

Then by equation (1) and inequality (44) we have

$$\text{TD}(Q_{\mathbf{Z}}, W^n(\mathbf{x})) = \frac{1}{2} \sum_{\mathbf{z} \in \{0, 1\}^n} |Q_{\mathbf{Z}}(\mathbf{z}) - W^n(\mathbf{z}|\mathbf{x})| + \frac{1}{2} \left(1 - \sum_{\mathbf{z} \in \mathcal{T}_{W, \varepsilon}^n(\mathbf{x})} W^n(\mathbf{z}|\mathbf{x})\right) \leq \mu_n. \tag{46}$$

By the equipartition property of conditional typical set [Wil13, Section 14.9.2], for any  $\mathbf{x} \in \{0, 1\}^n$  and  $\mathbf{z} \in \mathcal{T}_{W, \varepsilon}^n(\mathbf{x})$ ,

$$2^{-n(H(Z|X)_{W \times P_{\mathbf{x}}} + c\varepsilon)} \leq W^n(\mathbf{z}|\mathbf{x}) \leq 2^{-n(H(Z|X)_{W \times P_{\mathbf{x}}} - c\varepsilon)}, \tag{47}$$

where  $P_{\mathbf{x}}$  is the empirical distribution of  $\mathbf{x}$ . Hence,  $\forall \mathbf{x} \in \{0, 1\}^n$ , we have

$$\begin{aligned}
H_{\min}^{\mu_n}(\mathbf{Z})_{W^A(\mathbf{x})} &\geq H_{\min}(\mathbf{Z})_Q && \text{[From inequality (46)]} \\
&= -\log \max_{\mathbf{z} \in \{0, 1\}^n} Q_{\mathbf{Z}}(\mathbf{z}) && \text{[From equation (2)]} \\
&= -\log \max_{\mathbf{z} \in \mathcal{T}_{W, \varepsilon}^n(\mathbf{x})} Q_{\mathbf{Z}}(\mathbf{z}) && \text{[From equation (45)]} \\
&= -\log \max_{\mathbf{z} \in \mathcal{T}_{W, \varepsilon}^n(\mathbf{x})} W^n(\mathbf{z}|\mathbf{x}) && \text{[From equation (45)]} \\
&\geq n(H(Z|X)_{W \times P_{\mathbf{x}}} - c\varepsilon) && \text{[From inequality (47)]} \\
&= l_n(p) && (48)
\end{aligned}$$

where the inequality follows from the definition in equation (4), and the second inequality follows from inequality (47).

**Step 3:** Prove inequality (41).

Construct the channel  $W' : \{0, 1\}^n \rightarrow \{0, 1\}^n$  as follows. For all  $\mathbf{x} \in \{0, 1\}^n$ ,

$$W'(\mathbf{z}|\mathbf{x}) = \begin{cases} 0, & \text{if } \mathbf{z} \notin \mathcal{T}_{W, \varepsilon}^n(\mathbf{x}) \\ W^n(\mathbf{z}|\mathbf{x}), & \text{if } \mathbf{z} \in \mathcal{T}_{W, \varepsilon}^n(\mathbf{x}) \end{cases}.$$

Similar to inequality (46) and (48), we have

$$\|W^n - W'\|_{\diamond} = \max_{\mathbf{x} \in \{0, 1\}^n} \text{TD}(W^n(\mathbf{x}), W'(\mathbf{x})) \leq \mu_n,$$

and

$$\begin{aligned}
\overleftarrow{H}_{\min}^{\mu_n}(W^n) &\geq \overleftarrow{H}_{\min}(W') \\
&= -\log \sum_{\mathbf{z} \in \{0, 1\}^n} \max_{\mathbf{x} \in \{0, 1\}^n} \frac{1}{2^n} W'(\mathbf{z}|\mathbf{x}) \\
&\geq l_n(p).
\end{aligned}$$

□