







A Calibratable Model for Fast Energy Estimation of MVM Operations on RRAM Crossbars

José Cubero-Cascante , Arunkumar Vaidyanathan , Rebecca Pelke , Lorenzo Pfeifer ,
Rainer Leupers , Jan Moritz Joseph 

RWTH Aachen University, Institute for Communication Technologies and Embedded Systems, Aachen, Germany
{cubero,vaidyanathan,pelke,pfeifer,leupers,joseph}@ice.rwth-aachen.de

Abstract—The surge in AI usage demands innovative power reduction strategies. Novel Compute-in-Memory (CIM) architectures, leveraging advanced memory technologies, hold the potential for significantly lowering energy consumption by integrating storage with parallel Matrix-Vector-Multiplications (MVMs). This study addresses the 1T1R RRAM crossbar, a core component in numerous CIM architectures. We introduce an abstract model and a calibration methodology for estimating operational energy. Our tool condenses circuit-level behaviour into a few parameters, facilitating energy assessments for DNN workloads. Validation against low-level SPICE simulations demonstrates speedups of up to 1000× and energy estimations with errors below 1%.

Index Terms—RRAM, 1T1R, MVM, Energy

I. INTRODUCTION

With the steep rise in the adoption of AI, its power demand surged. Novel approaches that substantially reduce power consumption are needed to achieve a sustainable use of AI. Architectures built around emerging Compute-in-Memory (CIM) technologies have the potential to reduce the energy of data-intensive workloads drastically. They mitigate the memory wall in traditional von Neumann systems, as costly data movements are reduced [21].

One emerging memory class is non-volatile resistive memory, such as Resistive Random Access Memory (RRAM) and Phase Change Memory (PCM). It enables considerable power savings via low-energy analogue computations [25]. Further advantages are the absence of leakage power and the multi-bit storage capability [30]. In RRAM-based CIM systems, the memory cells are arranged in crossbars that compute Matrix Vector Multiplications (MVMs), a fundamental operation in Deep Neural Networks (DNNs), in $\mathcal{O}(1)$ time complexity. This concept was integrated into several architectures [1], [12], [19], [20], [29].

Due to the considerable savings promised by CIM technology, numerous technology stacks, data representations, and peripheral circuits have been published, leaving behind a fragmented landscape. As established methods for performance analysis from digital CMOS cannot be directly used to evaluate the performance of analogue CIM systems, a custom framework is missing. A system-level evaluation of the power consumption for real-world AI algorithms is needed; hence, the framework

This work was funded by Germany's Federal Ministry of Education and Research (BMBF) in the project NEUROTEC II (Project Nos. 16ME0398K, 16ME0399).

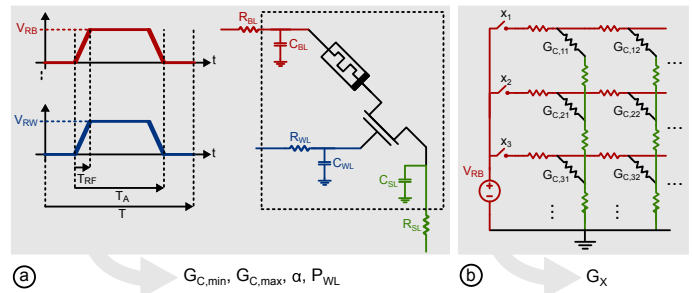

Fig. 1. The Gist of Our Energy Model: (a) Cell Calibration and (b) Crossbar Circuit Reduction Including Wire Parasitics

must yield high simulation performance. Device and circuit-level properties, such as the geometry of transistors and wire parasitics in 1T1R arrays, strongly affect energy efficiency. Thus, the framework must be calibrated to device-level simulations.

This work introduces the required fast and calibrated framework to quantify the combined effect of device properties, circuit designs, and system design decisions on the energy consumed by 1T1R crossbars in CIM-based systems. Our main contributions are:

- A methodology to study the effect of the selection transistor and wire parasitics in 1T1R crossbar arrays.
- A comparison of the energy budget of the state-of-the-art weight mappings for crossbar-based MVM operations.
- A calibrated and fast system energy model for MVM operations on resistive memory crossbars, enabling the evaluation of real workloads.

Fig. 1 illustrates the pivotal elements driving this work: cell calibration using read pulses and circuit reduction, including wire parasitic resistances.

II. BACKGROUND

A. Resistive MVM Compute Kernels

Resistive arrays enable dot-product operations in the analogue domain [10], as depicted in Fig. 2a. A vector $\mathbf{G} = [G_1, G_2, \dots, G_M]$ is encoded as the conductance of each resistive device, while the applied voltages $\mathbf{V} = [V_1, V_2, \dots, V_M]$ represent the second vector. According to Kirchhoff's Circuit Laws (KCL), the output current is $I = \sum_j^M V_j G_j = \mathbf{V} \cdot \mathbf{G}$. Each resistive element acts as storage and Multiply-Accumulate

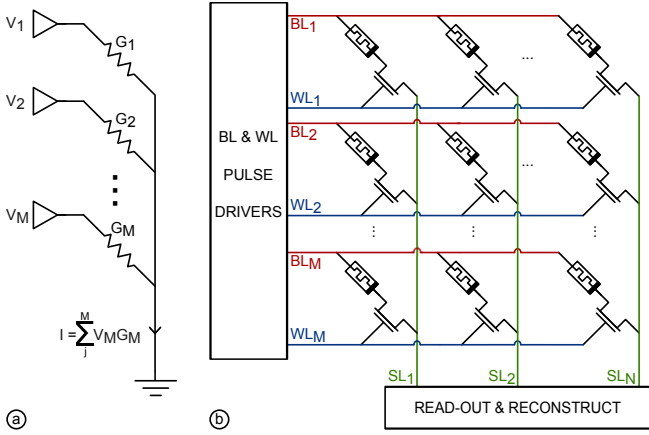

Fig. 2. Ideal Resistive Dot-product and 1T1R Crossbar

(MAC) unit simultaneously. A passive crossbar, built by expanding columns in Fig. 2a, realises a fully parallel implementation of the MVM operation.

Passive crossbars suffer from sneak-path currents, so their usage for multi-level cell storage is limited [23]. An established solution to this problem is providing each memristor with a transistor that acts as an access device, forming a 1T1R crossbar (see Fig. 2b). The transistor regulates the maximum current, enabling fine-tuning of individual conductances [21].

The integration of 1T1R cells in large crossbar arrays requires long metal wires that suffer from parasitic line resistance and capacitance. These parasitic elements affect the accuracy of computations but also impact energy efficiency [27].

B. CNN Workloads as MVMs

Convolutional Neural Networks (CNNs) are widely recognised and extensively utilised in various applications, including successfully detecting, segmenting, and recognising objects and regions in images [14].

In CNNs, the computationally intensive tasks primarily reside in the convolution layers [1]. To execute convolution layers on a resistive CIM kernel, they must first be translated into MVMs [17]. The *im2col* [28] transformation is a widely used technique for this purpose.

CNN acceleration with RRAM-based CIM kernels has been demonstrated in silicon by several works [12], [22], [29]. The trained weights of CNN layers are mapped to memristive crossbars, while input activations are encoded to a train of voltage pulses. Integer quantisation is usually applied to weights and activations before encoding [3], [13].

C. Weight Mapping

Memristive cells can only hold positive values between G_{min} and G_{max} . Therefore, negative weights have to be expressed as positive values. Furthermore, due to their intrinsic cycle-to-cycle variability, only a finite number of states are feasible [18].

There are two main weight mapping approaches [30]. With the *bias mapping*, signed weights are converted to conductances using a fixed scaling factor s and a bias G_b , so that $G_{ij} = sW_{ij} + G_b$. The bias G_b is set to $(G_{min} + G_{max})/2$ [19].

With the *differential mapping*, the weight values are represented with a pair of values, so that $sW_{ij} = G_{ij}^+ - G_{ij}^-$. Typically, G_{ij}^- is set to G_{min} for positive numbers and G_{ij}^+ is set to G_{min} for negative numbers [26].

After mapping, values can be programmed to one (bias) or two (differential) memristive cells. However, if the range of the integer quantisation is greater than the device achievable states, the value will be further split by applying *cell spatial bit-slicing* [19].

D. Input Encoding

Directly mapping arbitrary multi-bit input values to input voltages is hard to realise, as the memristor IV response is often linear only in a small range [2]. Moreover, Digital-to-Analogue Converter (DAC) and Analogue-to-Digital Converter (ADC) circuits are costly in terms of area and power [16]. A common solution is *input temporal bit-slicing*: passing the input values bit-by-bit [8]. This method is assumed for our analysis, as it is used in a significant number of CIM chips and architecture concepts [1], [10], [19], [22], [29].

III. METHODS

A. Cell Pulse Energy Model based on Calibration

We propose an abstract energy model with a small number of calibrated parameters. Our analysis starts at the 1T1R cell level, where the analogue MAC operations take place. As shown in Fig. 1a, the 1T1R cell circuit includes the memristive device, the selection transistor, and the unit wire parasitic capacitances for the three interconnect lines: BL, WL, and SL. The wire parasitic resistances are excluded, as their effect will be considered in the crossbar-level model in the next section.

A MAC operation is performed by applying pulses of amplitude V_{RB} and V_{RW} to the BL and WL lines, respectively. The pulses feature the same total T , activation T_A , and rise-fall T_{RF} times. Both BL and WL lines are activated simultaneously if the 1-bit input x is one and are kept low otherwise. The cell energy can be expressed as:

$$E_C = x(E_{WL} + E_{BL}) = xT(P_{WL} + P_{BL}). \quad (1)$$

P_{WL} corresponds to the average power delivered to the WL input in one pulse. This power stems from charging and discharging the gate capacitance and the parasitic wire capacitance C_{WL} . Its magnitude depends on the transistor geometry and the input pulse's parameters T_A and T_{RF} . However, it remains constant, disregarding the cell's resistive state.

Similarly, P_{BL} is the average power flowing into the BL input in one pulse. We define it as the product of the cell's steady-state power P_S and a calibration parameter α :

$$P_{BL} = \alpha P_S = \alpha V_C^2 G_C. \quad (2)$$

G_C is the cell's apparent conductance, which combines the memristor's state and the transistor's on-resistance R_{TON} . V_C is the voltage seen by the cell in the steady state. The calibration parameter α collects the transient elements, including the transistor switching energy and the charging and discharging of the parasitic capacitances C_{BL} and C_{SL} .

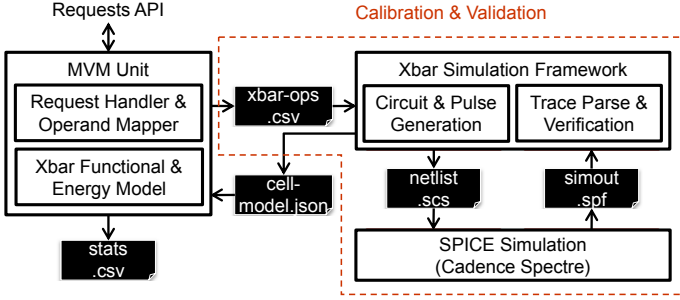

Fig. 3. Tools and Simulation Workflow

The resulting cell pulse energy equation is:

$$E_C = Tx(\alpha V_C^2 G_C + P_{WL}). \quad (3)$$

B. Total Crossbar MVM Energy

The crossbar's total MVM energy can be expressed as the sum of the energy of all cells and P pulses. For a crossbar with X_M columns and X_N rows, this is:

$$E_{MVM} = \sum_p^P \sum_i^{X_M} \sum_j^{X_N} E_{C,p,ij}. \quad (4)$$

Introducing the cell pulse energy from Eq. 3, we get:

$$E_{MVM} = T \sum_p^P (\alpha \sum_i^{X_M} \sum_j^{X_N} x_{p,j} V_{C,ij}^2 G_{C,ij} + X_M P_{WL} \sum_j^{X_N} x_{p,j}). \quad (5)$$

With the *input temporal bit-slicing* scheme, $x_{p,j}$ is a single-bit value, while P , T , and P_{WL} are constants. However, as illustrated in Fig. 1b, $V_{C,ij}$ is not constant due to the parasitic wire resistances. To address this variability, we employ the fast circuit solver from [4] to calculate the steady-state equivalent conductance $G_{X,p}$ that satisfies:

$$\sum_i^{X_M} \sum_j^{X_N} x_{p,j} V_{C,ij}^2 G_{C,ij} = V_{RB}^2 G_{X,p}. \quad (6)$$

Finally, the MVM energy becomes:

$$E_{MVM} = T \sum_p^P (\alpha V_{RB}^2 G_{X,p} + X_M P_{WL} \sum_j^{X_N} x_{p,j}). \quad (7)$$

C. Workflow

Fig. 3 shows the workflow and tools developed in this work. The *MVM Unit*, shown on the left side, implements the fast energy model. It receives MVM requests using signed or unsigned integer operands with a resolution of up to 16 bits. The incoming requests are translated into a set of *xbar-ops*, i.e. single pulse operations using the data types the target crossbar requires. This transformation includes mapping weights to conductances and applying bit-slicing when necessary. The *xbar-ops* are utilised by the *Xbar Functional & Energy Model* to generate the MVM output vector. Simultaneously, the MVM

 TABLE I
1T1R ARRAY CONFIGURATIONS

ID	Transistor $W \times L/\text{nm}$	Wire Parasitics		Conductance/ μS		Power/fJ	
		C/fF	R/ Ω	Min	Max	Min	Max
A	32×32	0	0	8.89	107.77	1.69	19.64
B	100×32	0	0	9.37	265.41	1.94	48.75
C	100×32	2	0	9.37	265.41	5.32	52.13
D	100×32	2	2.215	5.60	178.83	7.54	20.17

energy cost is computed using Eq. 7 and the calibrated cell parameters in *cell-model.json*.

When adding a new cell configuration, a calibration process is necessary. It consists of transient SPICE simulations of the single cell, pulse-based MAC operation described in Section III-A. A sweep over the conductance range of the target memristive device is done to extract the parameters $G_{C,min}$, $G_{C,max}$, α , and P_{WL} . Finally, the new cell's calibration parameters are stored in *cell-model.json*.

The SPICE simulations are done with Cadence Spectre. The memristive device is simulated using the *JART VCM-1B* [7] compact model, which has been fitted to a Valence Change Mechanism (VCM)-type $Pt/HfO_2/TiO_x/Ti$ cell. For the transistors, we use the PTM models from [5].

IV. RESULTS AND DISCUSSION

We select four 1T1R cell configurations to demonstrate our calibration methodology. These are compiled in Table I. The memristor model parameters from [7] are left unchanged, and only the transistor geometry and wire parasitics are modified. The wire parasitics' values are based on the estimations for 32nm technology in the International Technology Roadmap for Semiconductors (ITRS) [32]. The same pulse settings are used for the calibration of all cells. V_{RB} is set to 0.2 V and V_{RW} to 1.2 V. The common pulse length T is 10 ns, with 4 ns active time (T_A) and 1 ns rise-fall time (T_{RF}).

1000 MVMs are simulated on a 64×64 crossbar for each cell configuration to validate the energy model. The crossbar is initialised with random 8-bit unsigned integers with a rectified normal distribution. Binary input vectors with varying sparsity are provided as inputs. Compared to SPICE, our simulations are up to $1000 \times$ faster and yield energy estimations with an absolute error below 1% in all cases.

A. Cell Energy Budget

The energy contribution of all elements in the 1T1R cell against the total cell conductance G_C is plotted in Fig. 4. Configuration A uses a transistor with a geometry ratio W/L of 1, with a high on-state resistance R_{TON} and thus a low cell conductance range. Configuration B reduces the transistor's voltage drop by using a larger W/L . This change is done to broaden the read-out range, as suggested by [30]. In our case, this leads to an increase of $2.48 \times$ in the total energy. Configurations C and D illustrate the effect of wire parasitics. The calibration of configuration D requires a complete crossbar simulation. We consider a 64×64 crossbar and two cases. In case 1, all other cells are programmed to $G_{max}/16$, while in case 2, other cells are set to $G_{max}/2$. A drastic change in

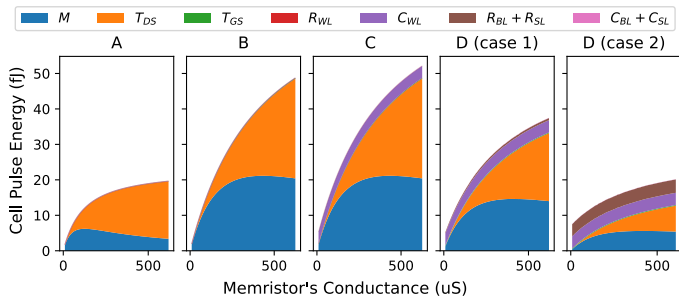

Fig. 4. Cell Energy Distribution

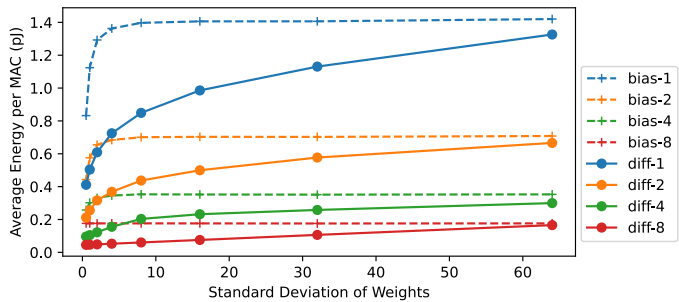

Fig. 5. Average Energy per 8-bit MAC Operation with Synthetic Data

the cell energy profile is observed in case 2, as the parasitic resistance dominates the power.

For simplicity, only configuration C is used for the experiments in the following sections.

B. Comparing Data Representations

We use our fast model to compare the energy cost of an 8-bit MAC operation for several cell bit-widths and weight mappings. This experiment uses synthetically generated data for the MVM weights and input vectors. The input vectors are uniformly distributed 8-bit unsigned integers. The signed weights are generated using a normal distribution centred at zero. The standard deviation is increased in powers of two.

The average energy per 8-bit MAC operation is depicted in Fig. 5. Differential mapping proves superior to the bias method, with a more noticeable distinction when the weights' standard deviation approaches zero.

C. Crossbar MVM Energy for CNN Workloads

The experiment with synthetic data helps compare data representations for the weights mapped in the crossbar cells. However, it does not show the influence of the input and output data of the MVM operations. To achieve this, we run experiments with actual weights and input data.

First, we obtained a set of pre-trained CNNs from the *Keras* applications database. We apply *tensorflow-lite* 8-bit quantisation [11] configured for signed weights and unsigned activations. We run 100 inference cycles with each CNN model using 100 images from the *imagenet* dataset. For all 2-dimensional convolutions (*Conv2D*), we apply the *im2col* transformation and generate energy statistics using our tool.

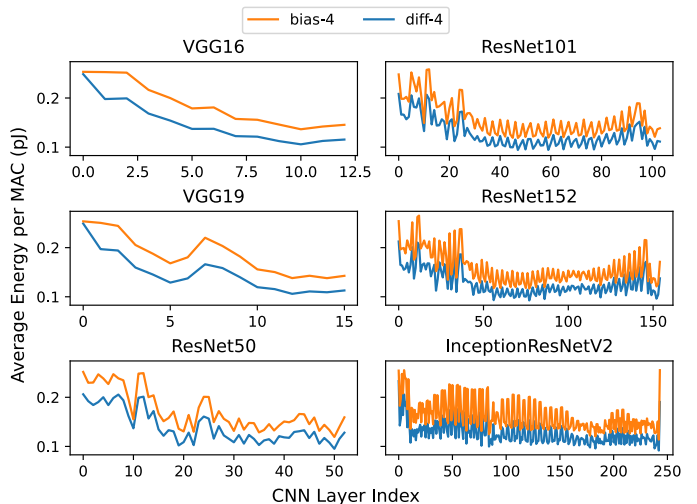

Fig. 6. Average Energy per 8-bit MAC Operation for CNN Workloads

We compute the average energy cost per 8-bit MAC operation for each convolutional layer. The results are plotted in Fig. 6. For simplicity, we only show the results obtained with 4-bit cells. The smaller networks, VGG16 and VGG19, show a decline in energy as the data travels towards the final layers. This pattern is also noticeable in the more complex networks Resnet50, Resnet101, and InceptionResNetV2. However, in the latter case, the required energy oscillates. Consistent with the observation in the previous section, the differential mapping outperforms the bias mapping in all cases.

V. RELATED WORK

The authors of [9] propose energy models for analogue SRAM-based CIM kernels. A detailed study on the performance and energy of 1T1R RRAM crossbars as storage media is presented in [31]. The work in [15] extensively analyses RRAM-based CIM kernels but only considers diodes as selection devices.

MNSIM [24] and NeuroSim [6] are two frameworks that offer energy statistics for RRAM CIM kernels, utilizing intricate circuit models with numerous configurable parameters. In contrast to our approach, none of these tools considers the impact of wire parasitic resistance on crossbar energy. Furthermore, our calibration-based method condenses circuit-level details into just a few parameters, enhancing simulation speed and facilitating system-level analysis.

VI. CONCLUSION

RRAM crossbars are at the core of numerous analogue CIM concepts for DNN acceleration. Assessing their energy efficiency requires a cross-layer approach considering circuit implementation details and workload properties. This work presents a methodology to achieve this through calibrated abstract models. Our analysis of state-of-the-art weight mapping schemes shows a clear advantage of differential-based schemes. Future work will extend our modelling approach to evaluate alternative circuit topologies, quantisation, and data representation schemes.

REFERENCES

- [1] A. Ankit *et al.*, "PUMA: A programmable ultra-efficient memristor-based accelerator for machine learning inference," in *Proceedings of the Twenty-Fourth International Conference on Architectural Support for Programming Languages and Operating Systems*, ser. ASPLOS '19. New York, NY, USA: Association for Computing Machinery, 2019, pp. 715–731.
- [2] C. Bengel, L. Dixius, R. Waser, D. J. Wouters, and S. Menzel, "Bit slicing approaches for variability aware ReRAM CIM macros," *it - Information Technology*, vol. 65, no. 1-2, pp. 3–12, 2023.
- [3] Y. Cai, T. Tang, L. Xia, B. Li, Y. Wang, and H. Yang, "Low bit-width convolutional neural network on RRAM," *IEEE Transactions on Computer-Aided Design of Integrated Circuits and Systems*, vol. 39, no. 7, pp. 1414–1427, 2020.
- [4] T. Cao, C. Liu, Y. Gao, and W. L. Goh, "Parasitic-aware modeling and neural network training scheme for energy-efficient processing-in-memory with resistive crossbar array," *IEEE Journal on Emerging and Selected Topics in Circuits and Systems*, vol. 12, no. 2, pp. 436–444, 2022.
- [5] Y. Cao and W. Zhao, "Predictive technology model for nano-CMOS design exploration," in *2006 1st International Conference on Nano-Networks and Workshops*, 2006, pp. 1–5.
- [6] P.-Y. Chen, X. Peng, and S. Yu, "NeuroSim+: An integrated device-to-algorithm framework for benchmarking synaptic devices and array architectures," in *2017 IEEE International Electron Devices Meeting (IEDM)*, 2017, pp. 6.1.1–6.1.4.
- [7] F. Cuijpers *et al.*, "Exploiting the switching dynamics of HfO₂-based ReRAM devices for reliable analog memristive behavior," *APL Materials*, vol. 7, no. 9, p. 091105, 09 2019.
- [8] S. Diware, A. Singh, A. Gebregiorgis, R. V. Joshi, S. Hamdioui, and R. Bishnoi, "Accurate and energy-efficient bit-slicing for RRAM-based neural networks," *IEEE Transactions on Emerging Topics in Computational Intelligence*, vol. 7, no. 1, pp. 164–177, 2023.
- [9] P. Houshmand, J. Sun, and M. Verhelst, "Benchmarking and modeling of analog and digital SRAM in-memory computing architectures," 2023.
- [10] M. Hu *et al.*, "Dot-product engine for neuromorphic computing: Programming 1T1M crossbar to accelerate matrix-vector multiplication," in *Proceedings of the 53rd Annual Design Automation Conference*, ser. DAC '16. New York, NY, USA: Association for Computing Machinery, 2016.
- [11] B. Jacob *et al.*, "Quantization and training of neural networks for efficient integer-arithmetic-only inference," in *2018 IEEE/CVF Conference on Computer Vision and Pattern Recognition (CVPR)*. Los Alamitos, CA, USA: IEEE Computer Society, jun 2018, pp. 2704–2713.
- [12] R. Khaddam-Aljameh *et al.*, "HERMES core - a 14nm CMOS and PCM-based in-memory compute core using an array of 300ps/lb linearized CCO-based ADCs and local digital processing," in *2021 Symposium on VLSI Technology*, 2021, pp. 1–2.
- [13] O. Krestinskaya, L. Zhang, and K. Salama, "Towards efficient RRAM-based quantized neural networks hardware: State-of-the-art and open issues," in *2022 IEEE 22nd International Conference on Nanotechnology (NANO)*, 2022, pp. 465–468.
- [14] Y. LeCun, Y. Bengio, and G. Hinton, "Deep learning," *Nature*, vol. 521, no. 7553, pp. 436–444, May 2015.
- [15] M. J. Marinella *et al.*, "Multiscale co-design analysis of energy, latency, area, and accuracy of a ReRAM analog neural training accelerator," *IEEE Journal on Emerging and Selected Topics in Circuits and Systems*, vol. 8, no. 1, pp. 86–101, 2018.
- [16] B. Murmann, "Mixed-signal computing for deep neural network inference," *IEEE Transactions on Very Large Scale Integration (VLSI) Systems*, vol. 29, no. 1, pp. 3–13, 2021.
- [17] R. Pelke, N. Bosbach, J. Cubero, F. Staudigl, R. Leupers, and J. M. Joseph, "Mapping of CNNs on multi-core RRAM-based CIM architectures," *arXiv preprint arXiv:2309.03805*, 2023.
- [18] S. K. Roy, A. Patil, and N. R. Shanbhag, "Fundamental limits on the computational accuracy of resistive crossbar-based in-memory architectures," in *2022 IEEE International Symposium on Circuits and Systems (ISCAS)*, 2022, pp. 384–388.
- [19] A. Shafiee *et al.*, "ISAAC: A convolutional neural network accelerator with in-situ analog arithmetic in crossbars," in *2016 ACM/IEEE 43rd Annual International Symposium on Computer Architecture (ISCA)*, 2016, pp. 14–26.
- [20] L. Song, X. Qian, H. Li, and Y. Chen, "PipeLayer: A pipelined rram-based accelerator for deep learning," in *2017 IEEE International Symposium on High Performance Computer Architecture (HPCA)*, 2017, pp. 541–552.
- [21] Z. Sun, S. Kvatinisky, X. Si, A. Mehonc, Y. Cai, and R. Huang, "A full spectrum of computing-in-memory technologies," *Nature Electronics*, vol. 6, no. 11, pp. 823–835, Nov. 2023.
- [22] W. Wan *et al.*, "A compute-in-memory chip based on resistive random-access memory," *Nature*, vol. 608, no. 7923, pp. 504–512, Aug 2022.
- [23] H.-S. P. Wong *et al.*, "Metal-oxide RRAM," *Proceedings of the IEEE*, vol. 100, no. 6, pp. 1951–1970, 2012.
- [24] L. Xia *et al.*, "MNSIM: Simulation platform for memristor-based neuromorphic computing system," in *2016 Design, Automation and Test in Europe Conference and Exhibition (DATE)*, 2016, pp. 469–474.
- [25] T. P. Xiao, C. H. Bennett, B. Feinberg, S. Agarwal, and M. J. Marinella, "Analog architectures for neural network acceleration based on non-volatile memory," *Applied Physics Reviews*, vol. 7, no. 3, p. 031301, 07 2020.
- [26] T. P. Xiao *et al.*, "On the accuracy of analog neural network inference accelerators," *IEEE Circuits and Systems Magazine*, vol. 22, no. 4, pp. 26–48, 2022.
- [27] T. P. Xiao, B. Feinberg, J. N. Rohan, C. H. Bennett, S. Agarwal, and M. J. Marinella, "Analysis and mitigation of parasitic resistance effects for analog in-memory neural network acceleration," *Semiconductor Science and Technology*, vol. 36, no. 11, p. 114004, oct 2021.
- [28] K. Yanai, R. Tanno, and K. Okamoto, "Efficient mobile implementation of a CNN-based object recognition system," in *Proceedings of the 24th ACM International Conference on Multimedia*, ser. MM '16. New York, NY, USA: Association for Computing Machinery, 2016, pp. 362–366.
- [29] P. Yao *et al.*, "Fully hardware-implemented memristor convolutional neural network," *Nature*, vol. 577, no. 7792, pp. 641–646, Jan 2020.
- [30] S. Yu, H. Jiang, S. Huang, X. Peng, and A. Lu, "Compute-in-memory chips for deep learning: Recent trends and prospects," *IEEE Circuits and Systems Magazine*, vol. 21, no. 3, pp. 31–56, 2021.
- [31] M. Zangeneh and A. Joshi, "Performance and energy models for memristor-based 1T1R RRAM cell," in *Proceedings of the Great Lakes Symposium on VLSI*, ser. GLSVLSI '12. New York, NY, USA: Association for Computing Machinery, 2012, pp. 9–14.
- [32] "International technology roadmap for semiconductors ITRS," Semiconductor Industry Association, Tech. Rep., 2013. [Online]. Available: <https://www.semiconductors.org/resources/2013-international-technology-roadmap-for-semiconductors-itsr/>