

A 97% Peak Efficiency Single-Inductor-Multiple-Output DC-DC Converter with a Shared Bootstrap Gate Driver

Mohammadreza Zeinali

Electrical and Computer Engineering Dept., University of California, Los Angeles (UCLA), Los Angeles, CA, USA

Email: zeinali@ucla.edu

Abstract

This paper describes a SIMO DC-DC converter capable of generating all the required voltages (buck and boost) utilizing n-type transistors for the output switches. The design incorporates only one shared bootstrap capacitor and a single pad to connect the top plate of the off-chip bootstrap capacitor to the on-chip drivers. By utilizing one off-chip bootstrap capacitor and sharing it between the multiple outputs, this work presents a low cost and low area solution for implementing a SIMO DC-DC converter using n-type transistor switches. A prototype of the proposed SIMO DC-DC converter is fabricated in 180nm SILTERRA BCD Technology.

Keywords: SIMO, switching DC-DC converter, bootstrap gate driver, shared driver, high efficiency, high voltage driver.

Introduction

Applications involving feature-rich system-on-chip (SoC) designs necessitate the use of multiple power supplies to enhance overall system performance and minimize power consumption. To achieve this, direct current (DC)-DC converters are commonly employed to convert a single power supply into multiple ones. Among the various converter types, switching LC DC-DC converters stand out, utilizing a capacitor and an inductor for each output regulated power supply. Despite their popularity, challenges such as electromagnetic interference, components costs, and physical size constraints limit the practicality of employing multiple inductors. A promising alternative lies in single-inductor-multiple-output (SIMO) DC-DC converters, particularly suitable for power management integrated circuits [1-4]. These converters offer the advantages of being both space- and cost-effective. Operation of such converters relies on charging the inductor current and discharging it into the output capacitor to regulate its voltage. As a result, a series of switches are involved, and the power efficiency of these converters is closely tied to the on-resistance of these switches. Consequently, minimizing the on-resistance of switches becomes a key objective. When considering a specific on-resistance, the preference for n-type transistor switches over p-type transistor switches arises due to the higher electron mobility in n-type transistors. However, the use of n-type transistors comes with the challenge of requiring a gate voltage higher than source voltage for turning on the switch, leading to the necessity of incorporating bootstrap gate drivers [1], [3]. An inherent drawback in employing a bootstrap gate driver lies in the need for a large off-chip capacitor to be charged in one phase, and subsequently applying the capacitor's voltage to the V_{gs} of n-type transistor in the next phase. This, in turn, may demand the utilization of N off-chip bootstrap capacitors and

2N pads on a chip to regulate N output voltages, resulting in a design that is not only complex but also cost-intensive.

Shared Bootstrap Gate Driver

This paper describes a SIMO DC-DC converter capable of generating all the required voltages (buck and boost) utilizing n-type transistors for the output switches. The design incorporates only one shared bootstrap capacitor and a single pad to connect the top plate of the off-chip bootstrap capacitor to the on-chip drivers. By utilizing one off-chip bootstrap capacitor and sharing it between the multiple outputs, this work presents a low cost and low area solution for implementing a SIMO DC-DC converter using n-type transistor switches.

Fig.1 shows the conventional SIMO DC-DC converter on the left and the proposed SIMO DC-DC converter using only a single shared bootstrap capacitor on the right. In the conventional design, each n-type output transistor uses its own large off-chip bootstrap capacitor which occupies 2 extra pads per output on the chip. This is while the proposed architecture uses a single shared bootstrap capacitor between the multiple outputs that requires only one extra pad on the chip for all outputs. For a SIMO DC-DC converter with N outputs, the proposed structure requires N-times lower off chip area and 2N-1 less pads on the chip compared to the conventional design.

Fig.2 shows the circuit details of the proposed SIMO DC-DC converter with only a single shared bootstrap capacitor. Each output has its own output delivery network S_{out_j} (including two n-type transistor switches M_{n_L-j} and M_{n_R-j} and one diode D_j) and its own driver network (including a $High_Side_P_type_Driver_j$ driving a p-type transistor M_{p_j} and a $High_Side_N_type_Driver_j$ driving a n-type transistor $M_{n_g_j}$). Two transistors M_{n_L-j} and M_{n_R-j} are placed in a manner to have back-to-back source to drain diodes to guarantee that the current passes only through the on-resistance of the switches. This is because the body of these transistors are not accessible in this technology. The single shared off-chip bootstrap capacitor shares one pad with the V_{L+} of off-chip inductor where its bottom plate is connected and just a single extra pad is required to connect its top plate to the on-chip drivers. The controller accepts the outputs as the input and delivers a control signal per output for controlling the output drivers. The operation of the proposed driver is as follows:

- 1) By turning on S_p and S_y switches, inductor current will be charged based on $V_{in} = L \frac{di}{dt}$. It is worth mentioning that in this phase, the bottom plate of bootstrap capacitor is also connected to gnd. Consequently, the bootstrap capacitor is charged to V_c through diode D_B which is the required voltage to turn on output switches correctly.

2) In the next phase one of the output switches should be turned on to discharge the inductor current to the output capacitor and regulate its voltage. The interesting point is that when the output switch is turned on (i.e., S_{outj}) and S_y switch is off, the three nodes V_{L+} , V_{Sj} , and V_{outj} are equal and are connected to the bottom plate of the bootstrap capacitor. As a result, the top plate of the bootstrap capacitor will be equal to $V_{outj} + V_C$ which will be connected to the gate of the output switch through M_{pj} switch.

The detailed implementation of a single output driver network is shown in Fig.3. The VSG voltage of the p-type driver transistor is provided through the resistor divider formed by R_1 and R_2 and enabled by the bottom n-type transistor Mn_{5j} . Also, the four stacked diode-connected n-type transistors Mn_{1j} to Mn_{4j} connected in parallel to R_1 limit the source gate voltage of the p-type driver transistor (to the value of four times of the gate-source voltage of n-type transistors Mn_{1j} to Mn_{4j}).

Measurement Results

Fig.4 illustrates the operation of proposed SIMO converter to generate four output voltages and waveforms of critical nodes including inductor current (I_L), V_{L+} , and V_{C+} , where from left to right, 1st on-chip output produces 12V, then the 1st

off-chip output provides 10V and then the 2nd off-chip output generates 3.3V and finally the 2nd on-chip output provides 1.8V. The top plate voltage of the shared bootstrap capacitor stands $V_C=5V$ higher than the selected output while in the idle time it keeps at 5V. When the selected output is ready the triangle-shaped inductor current peaks about 135 mA. The ripple of the measured on-chip 12V and 1.8V outputs are demonstrated respectively in Fig.5 which is lower than 20 mV.

Fig. 6 shows a comparison between this work and the State-of-the-Art SIMO converters based on the number of bootstrap capacitors and pads used to drive the output switches. It is obvious that n-type switches can provide better efficiency due to lower on-resistance in the same switch area.

A prototype of the proposed SIMO DC-DC converter with two on-chip outputs and two off-chip outputs is fabricated in 180nm SILTERRA BCD Technology for which the chip micrograph is shown above. Two output driver and delivery networks are implemented on-chip and the other two are implemented off-chip due to limited chip area while all four outputs share the same single off-chip bootstrap capacitor.

References

[1] M. -y. Jung *et al.*, *ISSCC*, 2015, pp. 1-3. [2] Y. -P. Su *et al.*, *ISSCC*, 2015, pp. 1-3. [3] A. Salimath *et al.*, *ISSCC*, 2018, pp. 426-428. [4] S. Kim *et al.*, *ISSCC*, 2023, pp. 10-12. [5] M. Zeinali *et al.*, *US Patent US11824448B2*, 2023.

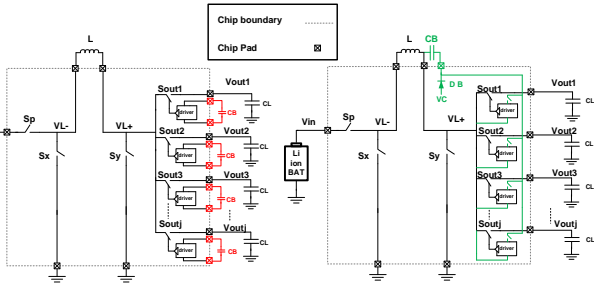

Fig.1 Structure of conventional SIMO converter with N bootstrap capacitors and 2N pads for N output supply voltages (left), and proposed SIMO converter with a shared bootstrap capacitor and only one pad to drive N output switches (right).

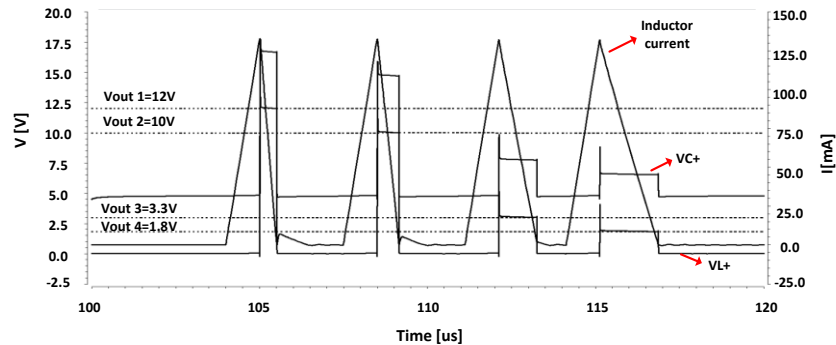

Fig.4 Waveforms of critical nodes (V_{L+} , V_{C+} , and Inductor current).

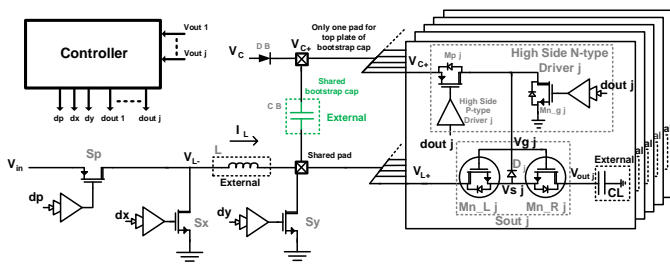

Fig.2 Proposed SIMO DC-DC converter with shared bootstrap capacitor driver.

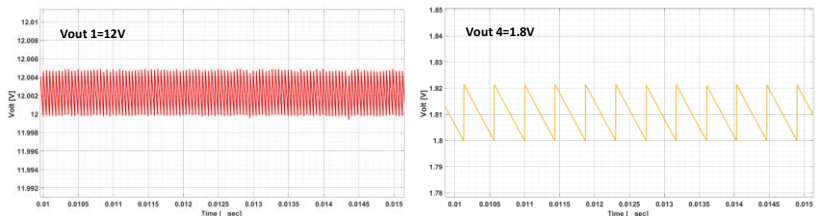

Fig.5 Waveforms and ripples of two output voltages generated using on-chip switches.

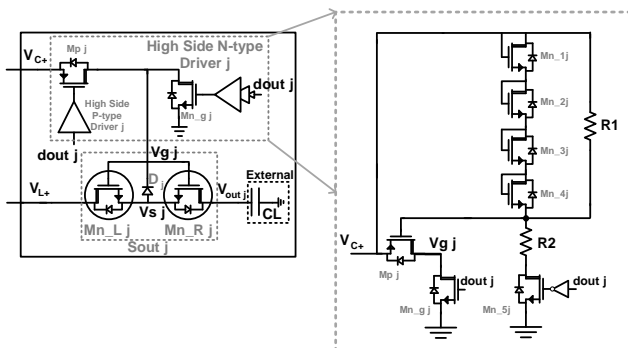

Fig.3 Schematic of the high side N-type driver and P-type driver.

	ISSCC' 2015 [1]	ISSCC' 2015 [2]	ISSCC' 2018 [3]	ISSCC' 2023 [4]	This work	
Input Voltage (V)	5	3.6-5	4-40	1.8	1.5-4.2	
Number of Outputs (Range)	10 (1.8/2.5/2.8/3.3)	4 (1.2-3.3)	3 (1.8/4.5/2.1)	4 (0.8-1.4)	4 (1-12)	
Max. Efficiency	88.7%	90%	86%	87.3%	97%	
Gate Drive Cost	Bootstrap capacitors	0-PMOS Switches	4	3	0-PMOS Switches	
	Number of Pads for bootstrap capacitor	0	8	6	0	1
	Switch area (mm ²)	0.44	0.15	0.12	0.14	0.07
Ripple (mV)	<40	<17	<25	<20	<20	
Switching Frequency	0.7 MHz	1 MHz	2.4 MHz	10 MHz	0.2-10 MHz	
Technology	350 nm	250 nm	110 nm	16nm	180 nm	

Fig.6 Comparison of this work with the recent State-of-the-Art SIMO converters.

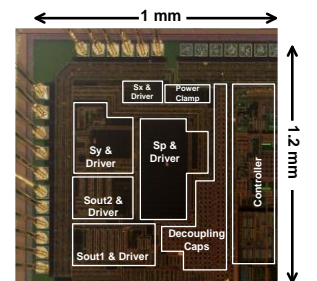

Fig.7 Chip micrograph of the proposed SIMO converter.