

Self-heating effect in nanoscale SOI Junctionless FinFET with different geometries

A.E. Atamuratov, B.O. Jabbarova, M.M. Khalilloev
 Physics department
 Urgench State University
 Urgench, Uzbekistan
 email: atabek.atamuratov@yahoo.com

A. Yusupov
 Department of Electronics and Electrical Engineering
 Tashkent University of Information technologies
 Tashkent, Uzbekistan
 email: ayus@mail.ru

A.G.Loureiro
 Department of Electronics and Computer Sciences
 University of Santiago de Compostella
 Santiago de Compostella, Spain
 email: antonio.garcia.loureiro@usc.es

Abstract—In this work we study the self-heating effect (SHE) in nanoscale Silicon on Insulator Junctionless (SOI JL) FinFET transistor with fin cross section in rectangular, trapeze and triangle form. The lattice temperature dependence on the channel length as well as on buried oxide thickness is considered. It is shown that for considered transistor structure the lattice temperature in the middle of the channel is lower than at lateral sides, near source and drain. Also, we have found at the same conditions the lattice temperature depends on shape of channel cross section too.

Keywords—Junctionless FinFET, self-heating effect, thermal conductivity, lattice temperature, channel cross section shape

I. INTRODUCTION

The scaling of the metall-oxide-semiconductor field effect transistors (MOSFET) is one of the main trends of electronics based on CMOS technology. Decreasing of the transistor sizes leads to decreasing of the consuming energy and increasing the integration degree in integral circuit. However, alongside with it the different degradation effects such as short channel effects [1], decreasing of reliability [2] and SHE [3] can appear. For decreasing the short channel effects SOI technology and multigate FinFET, particularly Junctionless FinFET structure were proposed [1]. However, the low thermal conductivity of buried oxide induces SHE in the channel and decreasing the drain current.

Besides it, at manufacturing nanoscale transistors, in technological processes, can be observed deviations of geometrical sizes from stipulated one. For FinFET this deviations can lead to change the stipulated transistor channel shape [4]. Therefore in this work SHE in SOI JL FinFET with different geometries is analyzed.

II. SIMULATION PROCEDURE

We have studied a SOI JL FinFET with a equivalent thickness of HfO_2 gate oxide $t_{ox}=0.9$ nm, and the width of

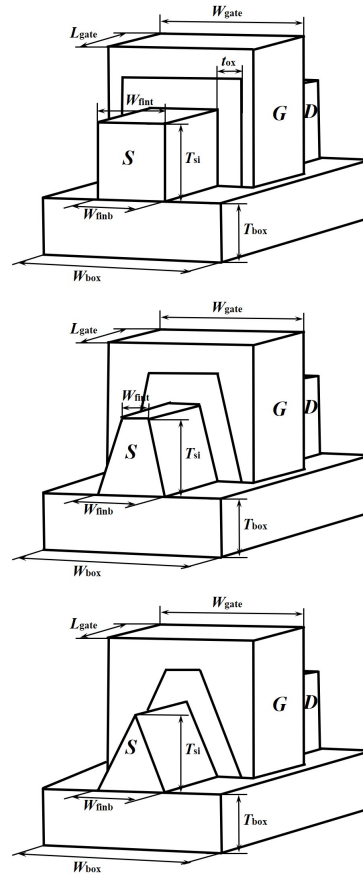

Fig. 1: Id-Vg characteristics of inversion mode FinFET (1) and accumulation mode JL FinFET (2) with the same geometric parameters.

SiO_2 buried oxide (BOX) is $W_{box}=69.4$ nm. The thickness of the BOX varies between $T_{box}=10$ nm and 150 nm and the length of TiN gate between $L_{gate}=10$ nm and 40 nm. Another

main values are: the thickness of the n-Si channel $T_{Si} = 9$ nm, width in the base $W_{finb} = 22$ nm and width in the channel top depend on the channel shape, which for considered trapeze cross section is $W_{fint} = 10$ nm, and is zero for triangle cross section (Figure 1).

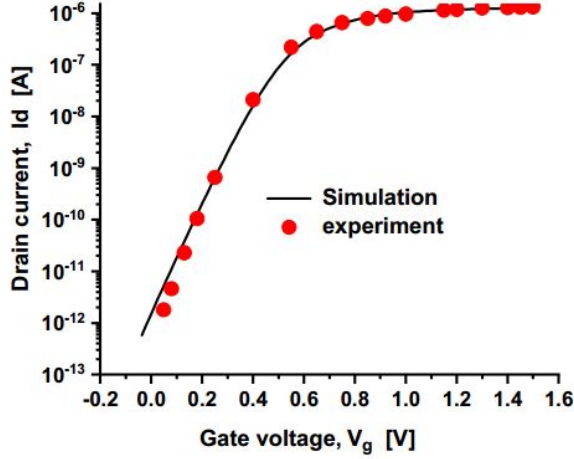

Fig. 2: Id-Vg dependence for simulated and experimental devices. $V_{ds} = 0.9$ V.

The device simulations were carried out using Advanced Sentaurus TCAD. For device simulation, along with default carrier transport model, mobility degradation model such as doping dependence to account impurity scattering effect were considered. High field saturation model were used to take into consideration velocity saturation effect. Transverse field effect is included to involve degradation at interfaces. To account self-heating, a thermodynamic model for carrier transport, SRH (temperature dependent) models were included. Density gradient quantization model and mobility degradation due to high-k materials were also taken into consideration. Figure 2 shows the very good fitting of transfer characteristics of designed SOI JL FinFET with experimental, presented in [5]. Experimental and simulated SOI JL FinFET with rectangular cross sections of the channel have the following geometric parameters: gate length $L_g = 13$ nm, equivalent gate oxide thickness $t_{ox} = 1.2$ nm, height of the channel $T_{Si} = 9$ nm, width of the channel $W = 22$ nm.

III. SIMULATION RESULTS AND DISCUSSION

In the Figure 3 the Id-Vg characteristics for SOI JL FinFET with rectangular cross section, without and with accounting self-heating effect is shown. Simulation results shows, SHE in the nanoscale SOI JL FinFET induces substantial decreasing of the drain current at high drain and gate voltages. It is connected with influence of the temperature induced by self-heating effect to mobility and gate capacitance [6].

On the lattice temperature distribution along the device length it is seen that at the middle of the length (in the channel) the temperature is lower than in lateral parts, near source and

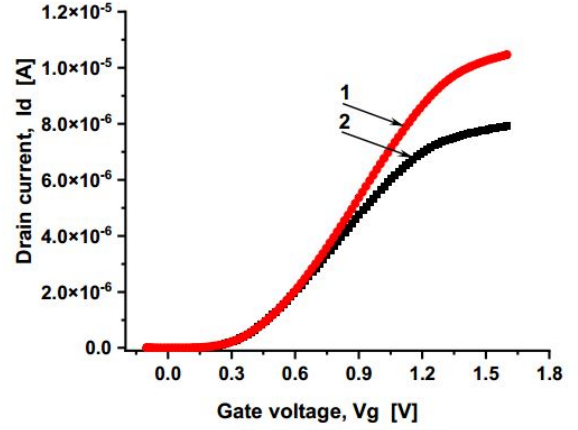

Fig. 3: Transfer characteristics of SOI JL FinFET with rectangular cross section, without (1) and with (2) accounting the self-heating effect. $V_{ds} = 0.75$ V.

drain (Figure 4). It is due to different materials which surround middle (gate oxide) and lateral parts (air). Besides it, in the middle part along device length, in bottom and top of the fin the temperature is lower than in the middle of fin in vertical direction. It can be explained by more fast heat transfer at bottom and top silicon-oxide border. However, temperature dependence on position which is seen in the vertical direction at lateral parts is connected with more heat transfer through back oxide (bottom part of fin) than through air (top part of fin). Small decreasing of temperature at device edges is connected with heat transfer through contacts.

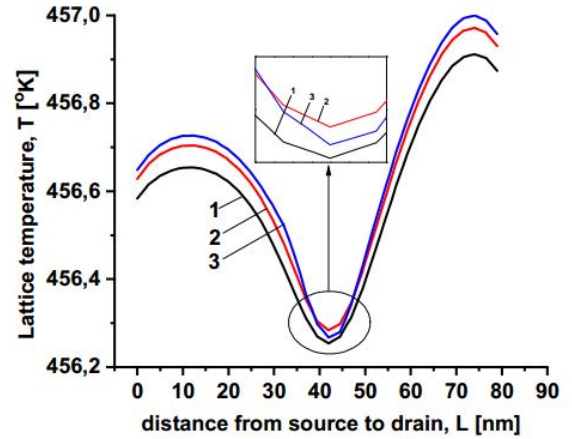

Fig. 4: Lattice temperature distribution along device with rectangular cross section at bottom (1), middle (2) and top (3) of the fin.

Figure 5 shows that lattice temperature is increased linearly with increasing the gate length. It is due to contribution of field normal component connected with gate voltage to electron kinetic energy. At increasing the gate length the number of free electrons in the channel covered by normal field is

increased. At the same channel height and the bottom width a volume (or area of cross section), therefore the number of free electrons, of the channel with rectangular cross section is higher than for channel with trapeze and triangle cross section. As consequence the number of electrons with high kinetic energy, therefore the channel temperature is high for transistor with rectangle cross section.

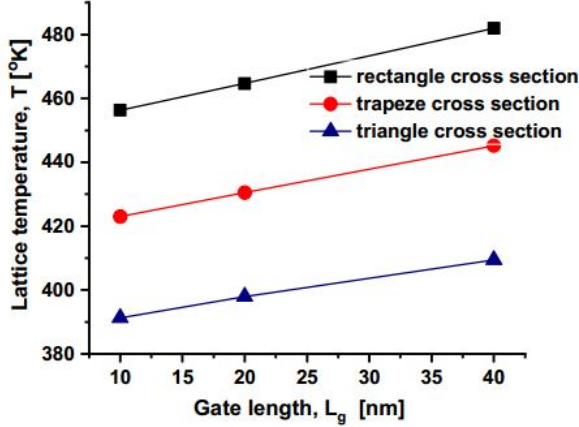

Fig. 5: Lattice temperature dependence on the gate length for transistors with different cross sections. $T_{box}=145$ nm

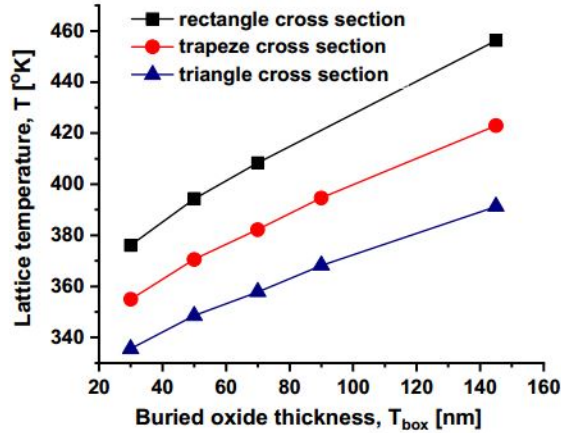

Fig. 6: Lattice temperature dependence on the buried oxide thickness. $L_g=10$ nm

Lattice temperature dependence on the buried oxide thickness is shown in the Figure 6. The lattice temperature is linearly increased with an increase in buried oxide thickness. It is agreed with model suggested in [7]. In accordance with this model the change of the lattice temperature of the channel linearly depends on the thickness of buried oxide T_{box} :

$$\Delta T = \frac{(P_t T_{box})}{(K_b A)} \quad (1)$$

where K_b is heat conductivity of back oxide material, P_t is heat dissipation power, A is contact area to back oxide. Increasing the lattice temperature with increasing the T_{box} is caused by increasing the distance between channel and thermal contact under buried oxide with increasing the T_{box} . Therefore increasing the T_{box} decrease the rate of removing the heat from the channel.

IV. CONCLUSION

From simulation study of SOI JL FinFET of perspective of self heating it is observed that self heating effect is different for transistors with rectangular, trapeze and triangle cross sections at the same bottom width and thickness of the channel. At the same conditions highest lattice temperature in the channel is observed in transistor with rectangular cross section. It is connected with larger area for rectangular cross section. Lowest temperature along channel is seen in the middle for all channel shapes. Lattice temperature, also, depend on gate length L_g and buried oxide thickness T_{box} and it is increased linearly with increasing L_g and T_{box} . Increasing the lattice temperature with increasing the gate length is result of increasing the area affected by normal gate field, which induce additional kinetic energy for electrons in the channel. Linear increasing the lattice temperature with increasing T_{box} is

consequence of increasing the distance between channel and contact under BOX.

V. ACKNOWLEDGMENT

This work has been supported by Ministry of innovative development of the Republic of Uzbekistan under contract Uzb-Ind-2021-80.

REFERENCES

- [1] I. Ferain, C. A. Colinge, and J. P. Colinge. Multigate transistors as the future of classical metal-oxide- semiconductor field-effect transistor. *Nature*, 479, 2011.
- [2] Yi Lin Yang, Wenqi Zhang, Shen-Yi Yan, Yin-Hung Yu, Zhen-Yu Fang, and Wen-Kuan Yeh. Study on device reliability for p-type finfets with different fi numbers. *Vacuum*, 181, 2020.
- [3] W. Ahn, S.H. Shin, C. Jiang, H. Jiang, M.A. Wahab, and M.A. Alam. Integrated modeling of self-heating of confied geometry (finfet, nwfet, and nshfet) transistors and its implications for the reliability of sub-20 nm modern integrated circuits. *AMicroelectronics Reliability*, 81:262–273, 2018.
- [4] A.Abdikarimov, G.Indalecio, N.Seoane E.Comesana, K.Kalna, A.J. Garsia-Lourero, and A.E.Atamuratov. Infnce of device geometry on electrical characteristics of a 10.7 nm soi-finfet. in *17th International Workshop on Computational Electronics (IWCE 2014), Conference, Paris, France.*, pages 247–248, 2014.
- [5] S.Barraud, M.Berthome, R.Coquand, M.Casse, T. Ernst, M. P.Samson, P. Perreau, K. K. Bourdelle, O.Faynot, and T. Poiroux. Scaling of trigate junctionless nanowire mosfet. *IEEE Electron Device Letters*, 33:1225–1227, 2012.
- [6] R. P. Nelapati and K. Sivasankaran. Impact of self-heating effect on the performance of hybrid finfet. *Microelectron*, 76:63–68, 2018.
- [7] L.J. McDaid, S. Hall, P.H. Mellor, W. Eccleston, and J.C. Alderman. Physical origin of negative differential resistance in soi transistors. *Electron. Lett.*, 25:827–828, 1989.