

Characteristics of the MTx optical transmitter in Total Ionizing Dose

D. Gong^a, S. Hou^{b,*}, B.J. Juang^b, J.-H. Li^{b,c}, C. Liu^a, T. Liu^a, M. Qi^d, J. Ye^a, Lei Zhang^d, Li Zhang^a, H.P. Zhu^e

^a Southern Methodist University, Dallas, TX 75205, U.S.A.

^b Institute of Physics, Academia Sinica, Taipei, Taiwan 11529

^c National Taiwan University, Taipei, Taiwan, 10617

^d Nanjing University, Nanjing, Jiangsu 210093, China

^e Institute of Nuclear Energy Research, Taoyuan, Taiwan 32546

Abstract

The dual-channel multi-mode 850 nm optical Miniature Transmitter (MTx) is developed for data transmission of the ATLAS LAr calorimeter readout at LHC. The MTx's are exposed to the radiation field of proton-proton collisions, therefore, the tolerance in Total Ionizing Dose (TID) is required. The TID effects in the MTx are investigated with X-rays and Co-60 gamma-rays for the active components of VCSEL diodes, and the customized Link-on-Chip laser driver (LOCld) developed in 0.25 μm Silicon-on-Sapphire CMOS technology. The irradiation tests were conducted at various dose rates. The responses to TID are observed with degradation of laser currents at initial dose of 10 to 100 Gy(SiO_2), and partial recovery with additional TID to a stable output about 90 % of the original. The optical eye diagrams of irradiated samples show slightly increased jittering, and are suitable for the ATLAS requirement of 5 Gbps applications.

PACS: 07.89+b; 42.60.-v; 42.79.-e; 42.88+h; 85.60-q

Keywords: LHC; Optoelectronic; Radiation hardness; ASIC

1. Introduction

The dual-channel optical Miniature Transmitter (MTx) is developed for applications in the ATLAS experiment at the Large Hadron Collider (LHC) [1, 2, 3]. The type of low-height (6 mm) assembly is shown in Fig. 1. Near 4k modules are produced for the Liquid Argon calorimeter (LAr) [4] and the muon New Small Wheel spectrometer (NSW) [5], for the Phase-I upgrade to enhance event trigger performance. The data transmission is conducted with the MTx and MTRx modules at 5.12 Gbps. The MTRx is a single channel MTx assembled with a customized "Receiver Optical Sub-Assembly" (ROSA) using a rad-hard GBTIA chip [6].

The MTx has two active devices, which are the Vertical-Cavity Surface-Emitting Laser (VCSEL) diode packaged in "Transmitter Optical Sub-Assembly" (TOSA), and the radiation tolerant "Link-on-Chip laser driver" (LOCld) [7, 8]. The LOCld is developed with the 0.25 μm Silicon-on-Sapphire (SoS) CMOS technology. The radiation with Total Ionizing Dose (TID) in

MOS materials creates electron-hole pairs, with holes being trapped in SiO_2 and defects formed at Si/ SiO_2 interfaces [9].

The MTx modules mounted on the LAr trigger digitizer boards are exposed to the radiation field of p - p collisions. Degradation of the laser light power by 7.5 %



Figure 1: The MTx module of lateral dimension 15 mm \times 45 mm is packaged with a high-density connector (LASHM-120-02.5-L-DV-A-N-TR, SAMTEC) and a customized LC fiber connector latch on the TOSAs (TTF-159, Truelight) to a total stack height of 6 mm.

*Corresponding author. E-mail address: suen@sinica.edu.tw

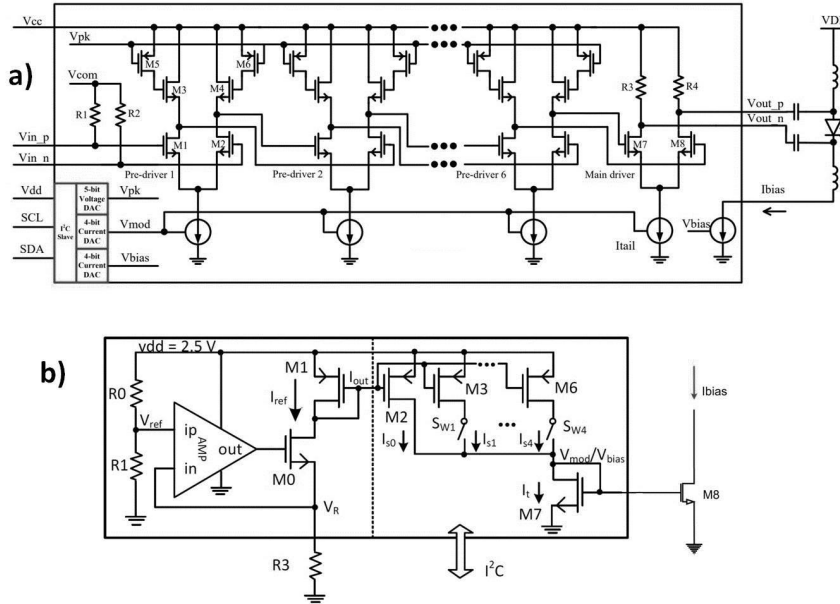

Figure 2: The circuit design of the dual-channel laser driver LOClD is plotted in a). The Vcc on driver stages and VDD on laser are biased at 3.3 V. The I²C communication and control block shown in the lower left corner is biased with Vdd at 2.5 V. The programmable current to the laser diode is illustrated in b).

is observed in the initial operation with p - p center-of-mass energy $\sqrt{s} = 13.6$ TeV in 2022, which corresponds to 11 fb^{-1} integrated luminosity¹. The simulation of radiation field suggests that the TID accumulated is $1.5 \text{ Gy}(\text{SiO}_2)$. The dose rate is at order of $0.01 \text{ Gy}(\text{SiO}_2)/\text{hr}$.

The LOClD prototypes had been evaluated with X-ray irradiation. To confirm the TID effects, studies with X-ray and Co-60 irradiations were conducted again for the dependence attributed to the VCSEL and the LOClD, on the difference of gamma sources, dose rates and annealing behaviors.

In Section 2, the MTx assembly and the LOClD laser driver design are described. The X-ray irradiation tests are discussed in Section 3. The degradation of MTx is examined for the bias currents and optical powers versus TID in increasing dose rates to $1.62 \text{ kGy}(\text{SiO}_2)$. The effects on eye diagrams at 5 Gbps are shown. Section 4 presents the Co-60 gamma-ray tests on VCSEL and MTx samples. The characteristic changes are compared for the dose rates and possible annealing behaviors, with the samples irradiated to various doses of up to $1.15 \text{ kGy}(\text{SiO}_2)$.

The most profound TID effects on MTx are observed with the degradation of LOClD laser currents that drops by about 15 % at the initial dose of 10 to 100 $\text{Gy}(\text{SiO}_2)$,

and recovers with additional TID, to 90 % of the original. The optical eye diagrams show slightly higher jitter noise and remain qualified for 8 Gbps data transmission. A short summary is discussed in Section 5.

2. MTx assembly with the LOClD ASIC

The MTx transmitter is designed for applications in the LHC radiation environment with more than ten years in operation [10, 11]. The module assembly for LAr (Fig. 1) has the TOSA packages held by a customized latch, and plug-in of fiber-optic cables terminated with LC-type ferrules. The LOClD is packaged in “Quad-Flat No-lead” QFN-40 format for assembly on the MTx module circuitry suitable for 10 Gbps speed performance. The schematics of the ASIC is plotted in Fig. 2.

The LOClD circuits have two bias voltages, with the 3.3 V to power the driver stages and the two laser driver channels, and the 2.5 V for the I²C communication and control block, respectively. The laser driver channels are composed of 6 stages of pre-driver and a main driver stage. Each pre-driver stage imposes active shunt peaking [12] to boost the bandwidth, and the peaking strength is programmable.

All of the pre-driver stages have the same structure but different transistor size, with the following pre-driver stage having larger transistor size and stronger driving capability. The main driver provides 50 Ohm

¹ATLAS LAr Phase I meeting, S. Menke, “LTDB power loss versus TID”, 26, October, 2022.

termination and programmable output modulation current for the VCSEL diode. The biasing current is programmable by a current source connected to the cathode of VCSEL diode. The output current to VCSEL is configured to 6 mA. The TOSA light output is specified in the range of 0.54 to 1.02 mW.

The prototype LOCld chips were irradiated with X-rays in biased condition and revealed degradation of laser current by about 7.5 % [13]. In Fig. 2.b the I²C configuration and the control circuits for the total current passing through the M7 are illustrated. The driver components M1-M8 are NMOS and PMOS devices, which are sensitive to TID induced defects [14].

3. MTx irradiated in X-ray

The X-ray irradiation was conducted in an X-RAD (iR160) radiator² that has the photon energy distributed in 10 – 160 keV. The radiation dose rate was calibrated with an Unfors Xi Transparent Detector³. The photon energy spectrum in air was measured with a 2-mm aluminum filter. The absorbed dose in SiO₂ was converted according to the mass-energy absorption coefficients of air and SiO₂ [15]. The dose rate uncertainty is estimated to be 6 % due to the geometrical offset and the photon energy distribution.

The MTx was prepared with the bias currents and optical powers recorded online. Two MTx samples were tested in sequence with the same dose rates and periods. The accumulated TID is 1.62 kGy(SiO₂). Plotted in Fig. 3 are the observables in consecutive doses. The irradiation started at the lowest tunable rate of 2.84 Gy/hr and lasted for 160 minutes to 7.59 Gy. Afterwards the rate was raised to 392 Gy/hr and then to 1.22 kGy/hr for an hour each.

The 3.3 V bias currents degraded rapidly by 25 % at around 100 Gy, and recovered partially with additional TID to 85 % of the original. The optical powers have similar characteristics and recover to 90 % of the initial level. Although the 2.5 V currents increased significantly by about 50 %, the I²C communications of both modules were functional.

The eye diagrams after irradiation have slightly increased jittering parameters. Plotted in Fig. 4 are the 5 Gbps eye diagrams of a module before and after the X-ray TID of 1.62 kGy. With the default configuration, the Optical Modulation Power (OMA) and Average Optical Power (AOP) are lower by about 15 % after irradiation.

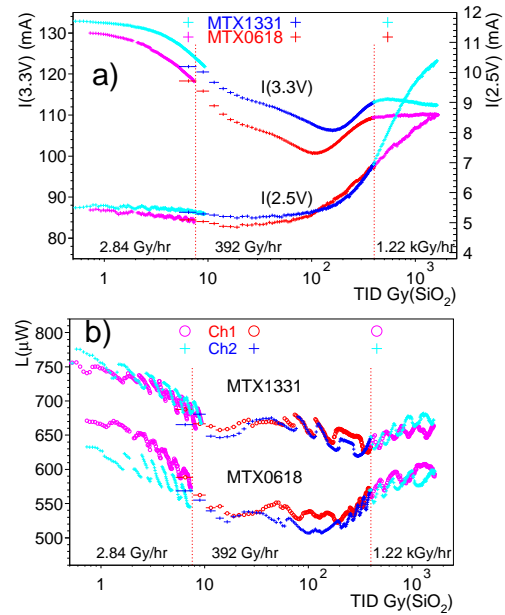

Figure 3: Two MTx samples were irradiated in X-ray at increasing dose rates, and accumulated to 1.62 kGy(SiO₂). The currents of the two bias voltages (3.3 V and 2.5 V) are plotted in a). The 3.3 V currents dropped instantly at initial TID, to the lowest level at around 100 Gy(SiO₂), and recovered afterwards. The 2.5 V currents increased significantly after 100 Gy(SiO₂). The optical powers plotted in b) correspond to the 3.3 V currents, and recovered to about 90 % of the original. The jagged curves represent the characteristic changes in the ASIC for the output currents to VCSELs.

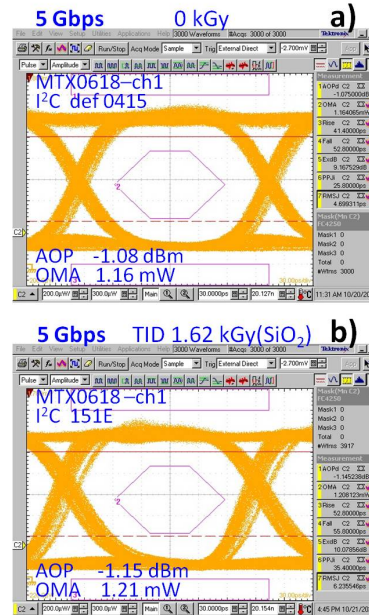

Figure 4: Eye diagrams of an MTx optical output channel at 5 Gbps, a) before and b) after the X-ray TID of 1.62 kGy(SiO₂). At the default configuration (I²C register value 0x0415), the 3.3 V current, AOP and OMA after TID dropped to 85 % of the original. In b), the I²C setting (0x151E) has tuned values to increase the AOP and OMA. However, the jitter noise (increased by 25 %) persists.

²Precision X-Ray Inc., Madison, CT, USA.

³Unfors RaySafe AB, Billdal, Sweden.

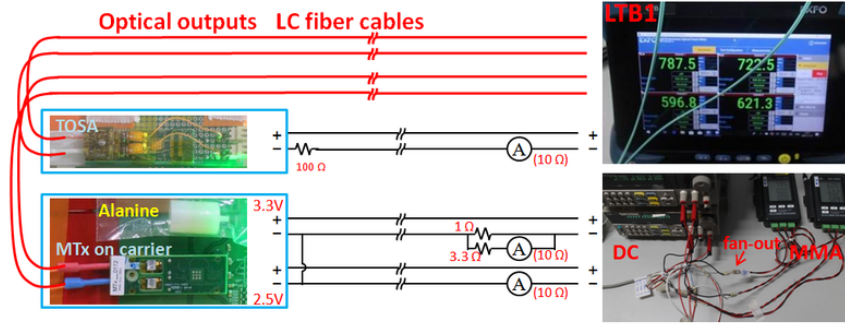

Figure 5: The Co-60 test setup is illustrated for the equipment connected with 40 m cables and fibers to the VCSEL and MTx samples. The test samples were attached with an Alanine dosimeter for TID calibration. The VCSEL optical powers were recorded by a four-channel meter (LTB1, EXFO). The currents of power supplies to TOSA and MTx samples were recorded with current meters (MMA-386SD). The parallel resistors to the 3.3 V ground were applied to extract a small fraction of current for the meter dynamic range limited to 20 mA.

By increasing the modulation voltage (V_{mod} in Fig. 2.b from 6.4 to 6.8 V), laser current (from 6 to 7 mA), and peaking strength (V_{pk}), the eye diagram (Fig. 4.b) is tuned with the AOP and OMA closer to the original before irradiation.

4. MTx irradiated in Co-60

The Co-60 irradiation of MTx was conducted at the Institute of Nuclear Energy Research (INER), where the gamma-ray facility has the Co-60 pellets of 10 mm diameter arranged in an array of $45 \times 300 \text{ cm}^2$, which provides a wider and uniform gamma ray distribution. The Co-60 test setup is illustrated in Fig. 5. The MTx samples in irradiation had an Alanine pellet closely attached. The absorbed dose in Alanine was measured by an electron paramagnetic resonance (EPR) analyzer⁴. The uncertainty is dominated by the geometric uniformity estimated to be 3 %.

The Co-60 emits gamma-rays of 1.1 and 1.3 MeV. With the photon energy larger than 120 keV, the mass-energy absorption coefficients are approximately equal for Alanine and SiO_2 . The dose-conversion factor applied is $1 \text{ Gy}(\text{SiO}_2) = 0.93 \text{ Gy}(\text{Alanine})$ [15].

The MTx modules in tests were kept at $22 \pm 4 \text{ }^\circ\text{C}$. By the distance of test objects to the source, with additional Pb shielding, the dose rates were configured from 0.14 to 45 $\text{Gy}(\text{SiO}_2)/\text{hr}$. The location of to power supplies and readout electronics is 40 m away in the external safe area. The data acquisition was recording every minute with a 4-channel optical power meter (LTB1) and current meters (MMA-386SD). The irradiation was

conducted daily during working hours. The data taking continued for source-off hours to detect annealing behaviors.

The VCSELs fabricated in GaAs substrate were tested independently for the TID effects. The GaAs mass-energy absorption coefficient in the Co-60 photon spectrum is about equal to the SiO_2 [16]. The same dose conversion factor is applied to the Alanine measurement.

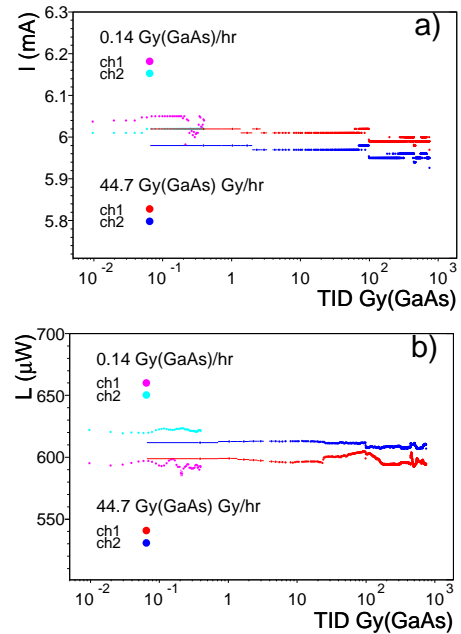

Figure 6: Two of the TOSA packaged VCSELs (TTF-1F59, Tru-erlight) were irradiated with Co-60 at constant currents of 6 mA, initially at 0.14 $\text{Gy}(\text{GaAs})/\text{hr}$ to 0.38 $\text{Gy}(\text{GaAs})$, and then at 44.7 $\text{Gy}(\text{GaAs})/\text{hr}$ to 1.59 $\text{kGy}(\text{GaAs})$. The currents and optical powers are plotted. The high rate is shown for the latest period of 0.74 $\text{kGy}(\text{GaAs})$. The steps were caused by accesses before source-on of working days.

⁴The AWM230 Alanine EPR Dosimeters were measured by a Bruker EMS 104 EPR analyzer.

The TOSA packaged VCSEL samples (TTF-1F59) were connected to power supplies at constant currents of 6 mA. The irradiation started at 0.14 Gy/hr to accumulate 5.77 Gy, and then at 44.7 Gy/hr to a total 1.59 kGy(GaAs). In Fig. 6 the TOSA currents and optical powers are plotted for periods of the two dose rates. The stable distributions suggest that the VCSELs are not affected by TID.

The degradation of MTx in TID is attributed by the characteristic changes in the LOCl. The irradiation initiated at 0.14 Gy/hr, with three MTx samples exposed to various total doses of 0.37 to 3.81 Gy(SiO₂). The reductions on currents and optical powers were instant, and deviated largely from 10 % to 15 %.

To accelerate the total dose accumulation, and for comparison of the dose rate dependence, the MTx samples were irradiated at 1.7, 18 and 45 Gy/hr. Plotted in Fig. 7 are the measurements of samples tested at 45 Gy/hr, to a total of 1.15 kGy(SiO₂). The responses observed are similar to those tested at lower rates. The currents and optical powers degraded with the initial doses of 10 to 50 Gy, and recovered partially with additional TID.

The two VCSEL diodes of a MTx, driven at ~6 mA,

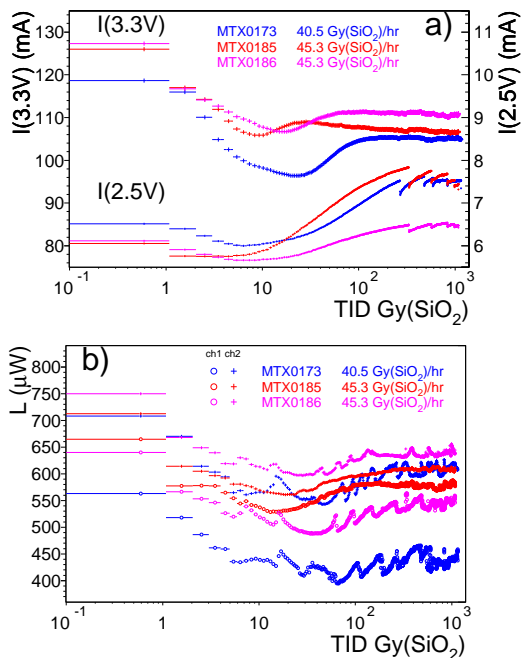

Figure 7: The a) bias currents and b) optical powers are plotted for three MTx's irradiated in Co-60 gamma-rays at 44.6 Gy(SiO₂)/hr to 1.15 kGy(SiO₂). The breaking steps in 2.5 V currents correspond to the annealing overnight to lower currents at the beginnings of source-on in each working day. The 3.3 V currents and optical powers degraded to the lowest at around 10 to 50 Gy, and recovered afterwards to 90 % of the original.

are biased by the 3.3 V that has a total current of 120 mA. The jagged curves of the optical outputs reflect the effects due to buildup of charges and defects in the driver circuits and current regulation, biased at 3.3 V and 2.5 V, respectively. The rate dependence is illustrated in Fig. 8, with the optical powers measured at four dose rates. At higher dose rates, the recovery is observed shifting from 10 Gy at 1.57 Gy/hr, to 100 Gy with the X-ray at 392 Gy/hr.

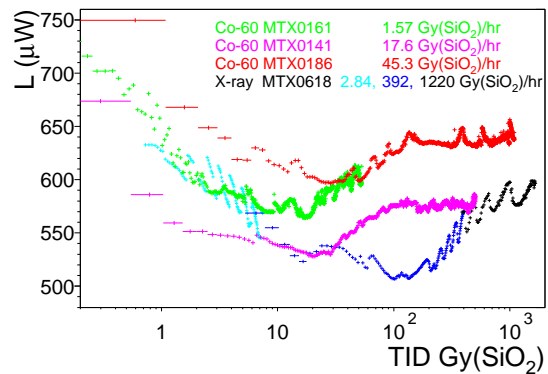

Figure 8: The laser light powers are shown for the irradiation with Co-60 at dose rates of 1.57 to 45.3 Gy(SiO₂)/hr, and with X-ray at increasing rates. The degradation and recovery occurred sooner with lower Co-60 dose rate. The X-ray irradiation was conducted without annealing, the recovery occurred around 100 Gy(SiO₂).

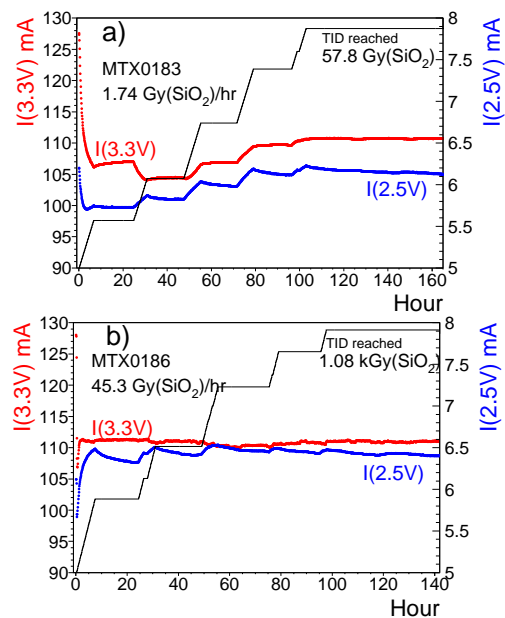

Figure 9: The currents in time of Co-60 irradiated samples at the dose rates of 1.74 and 45.4 Gy(SiO₂) are illustrated in a) and b), respectively. The accumulated TIDs in source-on and -off periods are indicated by the black lines, in five working days. The degradation of currents occurred quickly at the initial 10 Gy(SiO₂). The annealing is more effective at lower dose rate, and at the initial TID. The recovery in currents occurred before 100 Gy(SiO₂).

The annealing effect is visible on the 2.5 V currents. The LOClD bias currents measured in time are plotted in Fig. 9, for the dose rates of a) 1.74 and b) 45.3 Gy/hr, respectively. The doses accumulated are also plotted, to indicate the degradation and annealing during source-on/off hours, respectively. At low dose rate the recovery occurred around 20 Gy. The annealing is more effective in the initial doses.

In total fifteen MTx modules were tested in Co-60 irradiation. Each was conducted at a constant dose rate (between 0.14 to 45.3 Gy/hr), with the accumulated TIDs of 0.37 to 1.15 kGy. The eye diagrams of them were examined at 5 and 8 Gbps speeds. Plotted in Fig 10 are the eye diagrams of a MTx channel exposed to 1.15 kGy. The LOClD is configured with the parameters used for the X-ray irradiated samples (Fig. 4.b), to enhance the AOP and OMA magnitudes. The jitter parameter values are higher than the original by about 20 %. All the irradiated samples can pass 8 Gbps bit-error rate tests.

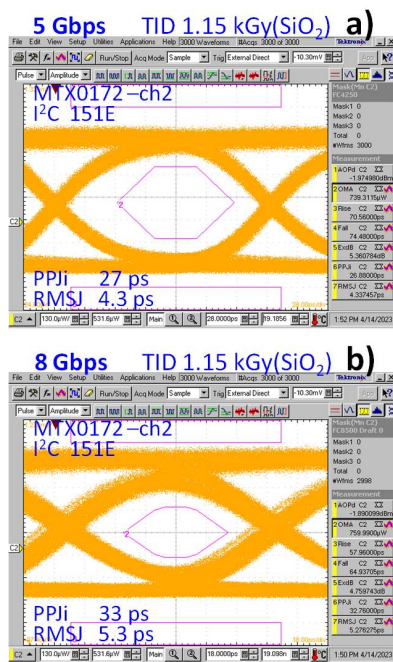

Figure 10: The eye-diagrams measured at a) 5 Gbps, and b) 8 Gbps are plotted for an MTx channel irradiated with Co-60 to 1.15 kGy(SiO₂). The LOClD configuration (I²C register 0x151E) is optimized for higher optical power. The Peak-Peak (PPJi) and RMS jitter parameters are larger by about 20 % with respect to the initial values before irradiation.

5. Summary

The radiation tolerance of the MTx transmitter in TID has been studied with X-rays to 1.62 kGy(SiO₂) and with Co-60 gamma-rays to 1.15 kGy(SiO₂). The degradation of LOClD output currents and optical powers occurs at initial TID to the lowest level at around 10 to 100 Gy(SiO₂), and recovers with increasing TID, to 90 % of the original. The results with X-rays and Co-60 gamma-rays are compatible. The 5 and 8 Gbps eye diagrams of Co-60 irradiated samples show similar increases on jitter parameters by about 20 %. The data transmission is qualified for the ATLAS applications at 5 Gbps speed.

Acknowledgement

The authors would like to thank the assistance of the Institute of Nuclear Energy Research. This work has been partially supported by the Institute of Physics, Academia Sinica, and the Ministry of Science and Technology, grant MOST 1082112-M-001-047.

References

- [1] C. Liu, et al., The miniature optical transmitter and transceiver for the High-Luminosity LHC (HL-LHC) experiments, JINST 8 (2013) C12027.
- [2] X. Zhao, et al., Mid-board miniature dual channel optical transmitter MTx and transceiver MTRx, JINST 11 (2016) C03054.
- [3] L. Zhang, et al., Optical transceivers for event triggers in the ATLAS phase-I upgrade, Nucl. Instrum. Methods A985 (2021) 164651.
- [4] ATLAS Collab, ATLAS Liquid Argon Calorimeter Phase-I Upgrade Technical Design Report, ATLAS-TDR-022, 2013.
- [5] ATLAS Collab, ATLAS New Small Wheel Technical Design Report, ATLAS-TDR-020, 2013.
- [6] M. Menouni, et al., The GBTIA, a 5 Gbit/s radiation-hard optical receiver for the SLHC upgrades, in: Proceedings of TWEPP-09, CERN-2009-006, 2009.
- [7] F. Liang, et al., The design of 8-Gbps VCSEL drivers for ATLAS liquid Argon calorimeter upgrade, JINST 8 (2013) C01031.
- [8] B. Deng, et al., Component prototypes towards a low-latency, small-form-factor optical link for the ATLAS Liquid Argon Calorimeter Phase-I trigger upgrade, IEEE Trans. Nucl. Sci. 62 (2015) 250.
- [9] T. R. Oldham and F. B. McLean, Total ionizing dose effects in MOS oxides and devices, IEEE Trans. Nucl. Sci. 50 (2003) 483.
- [10] S. Hou, et al., Radiation hardness of optoelectronic components for the optical readout of the ATLAS inner detector, Nucl. Instrum. Methods A636 (2011) S137.
- [11] F.X. Chang, et al., Aging and environmental tolerance of an optical transmitter for the ATLAS Phase-I upgrade at the LHC, Nucl. Instrum. Methods A831 (2016) 349.
- [12] F.-T. Liang, et al., Active inductor shunt peaking in high-speed VCSEL driver design, Chin. Phys. C 37 (2013) 116101.
- [13] X. Li, et al., 8-Gbps-per-channel radiation-tolerant VCSEL drivers for the LHC detector upgrade, JINST 10 (2015) C02017.
- [14] M.P. King, et al., Response of a 0.25 μm thin-film silicon-on-sapphire CMOS technology to total ionizing dose, JINST, 5 (2010) C11021.

- [15] F. Ravotti, Dosimetry Techniques and Radiation Test Facilities for Total Ionizing Dose Testing, IEEE Trans. Nucl. Sci. 65 (2018) 1440.
- [16] L.D. Edmonds, Dose Conversions between Different Materials, DOI:10.13140/RG.2.1.3145.7449, (2015).