

Mass testing of SiPMs for the CMVD at IICHEP

Mamta Jangra^{1,2*}, Raj Bhupen^{1,2}, Gobinda Majumder², Kiran Gothe², Mandar Saraf², Nandkishor Parmar², B. Satyanarayana², R.R. Shinde², Shobha K. Rao², Suresh S Upadhya², Vivek M Datar³, Douglas A. Glenzinski⁴, Alan Bross⁴, Anna Pla-Dalmau⁴, Vishnu V. Zutshi⁵, Robert Craig Group⁶ and E Craig Dukes⁶

1 Homi Bhabha National Institute, Mumbai-400094, India

2 Tata Institute of Fundamental Research, Mumbai-400005, India

3 The Institute of Mathematical Sciences, Chennai-600113, India

4 Fermi National Accelerator Laboratory, IL 60510, United States

5 Northern Illinois University, IL 60510, United States

6 Virginia University, VA, United States

* mamtajangra894@gmail.com

October 24, 2022



21st International Symposium on Very High Energy Cosmic Ray Interactions

(ISVHE- CRI 2022)

Online, 23-28 May 2022

Abstract

A Cosmic Muon Veto Detector (CMVD) is being built around the mini-Iron Calorimeter (mini-ICAL) detector at the transit campus of the India based Neutrino Observatory, Madurai. The CMV detector will be made using extruded plastic scintillators with embedded wavelength shifting (WLS) fibres which propagate re-emitted photons of longer wavelengths to silicon photo-multipliers (SiPMs). The SiPMs detect these scintillation photons, producing electronic signals. The design goal for the cosmic muon veto efficiency of the CMV is $>99.99\%$ and fake veto rate less than 10^{-5} . A testing system was developed, using an LED driver, to measure the noise rate and gain of each SiPM, and thus determine its overvoltage (V_{ov}). This paper describes the test results and the analysed characteristics of about 3.5k SiPMs.

Contents

1	Introduction	2
2	About Silicon photomultiplier	2
3	Experimental setup	3
4	Test Results	4
5	Summarised Results	5
6	Conclusion	5

2 mm×2 mm SiPM. The SiPMs are mounted on a panel as shown in Fig. 2 on the right and each panel has 16 SiPMs. The detailed view of a single SiPM is shown in the Fig. 2 on the left.

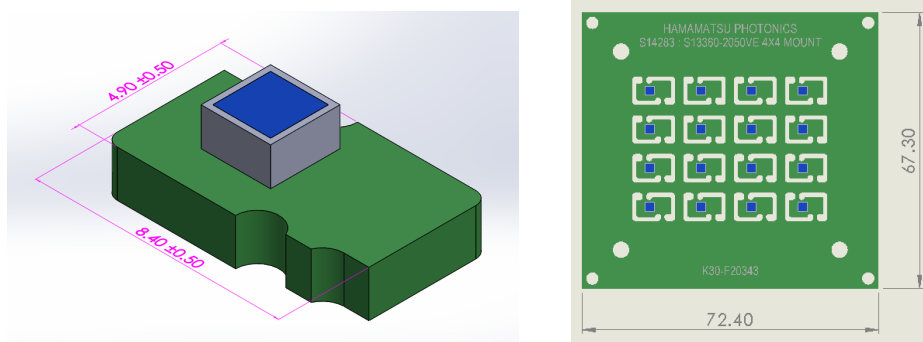

Figure 2: SiPM on a tiny carrier board (on left), a panel with 16 SiPMs (on right).

3 Experimental setup

The testing is performed in a lightproof black box. The SiPM panel is mounted on one of the face of the black box as shown in the Fig. 3. An LED system (CAEN SP5601) is used for the SiPM testing purpose. The LED system has an ultrafast LED driver which is used to expose the light on the SiPM panel. Along with the LED driver, the LED system has an external pulser with a trigger synchronized with the LED pulse. The LED driver can send a bunch of few photons upto tens of photons on every trigger.

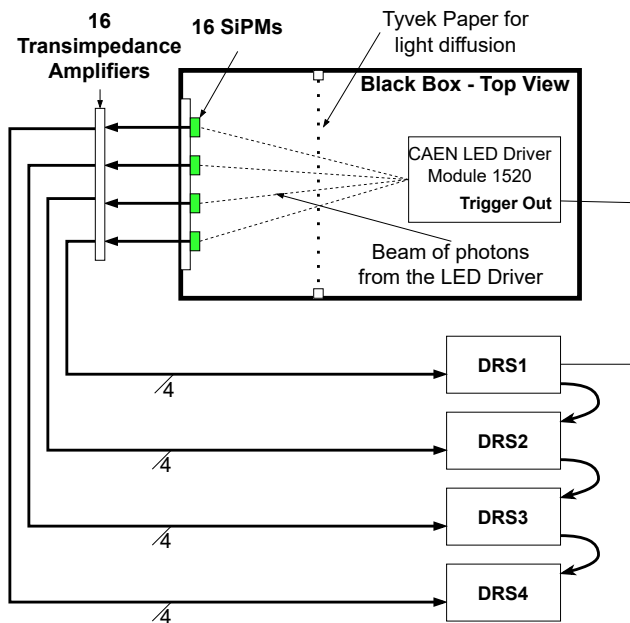

Figure 3: The SiPM mass testing experimental setup

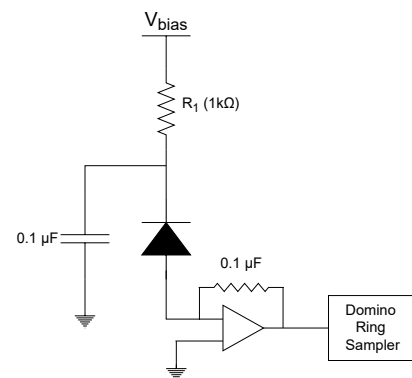

Figure 4: SiPM circuit diagram

A piece of tyvek paper is used to diffuse the light uniformly on all the SiPMs. The raw signals from all 16 SiPMs are amplified using transimpedance (TI) amplifiers [3] and the amplified signals are connected to Domino Ring Sampler (DRS) boards. A total of four DRS boards are used for this testing. For the data collection, the trigger from the external pulser is

sent to one of the DRS boards and it was synchronized with other DRS boards in a daisychain mode. The DRS boards are connected to a computer system to collect the data. A schematic of the electronic circuit for signal readout is shown in Fig. 4.

The charge generated by the SiPM is measured from the raw signals using the equation 1

$$q = \frac{1}{R \times G} \int_{t_0}^{t_1} V(t) dt \quad (1)$$

where R is the input resistance of the TI amplifier and G is the gain of the operational amplifier stage. A total of 218 SiPM panels were tested using this setup.

4 Test Results

A typical example of SiPM output signal in response to LED excitation is shown in Fig. 5a. For each SiPM, a total of 5000 events are collected. The signal is integrated within a 100 ns window for charge collection and the pedestal is subtracted to correct for the baseline fluctuations. The corresponding charge distribution with several photoelectron (pe) peaks is shown in Fig. 5b for one of the SiPMs at $V_{bias} = 54$ V.

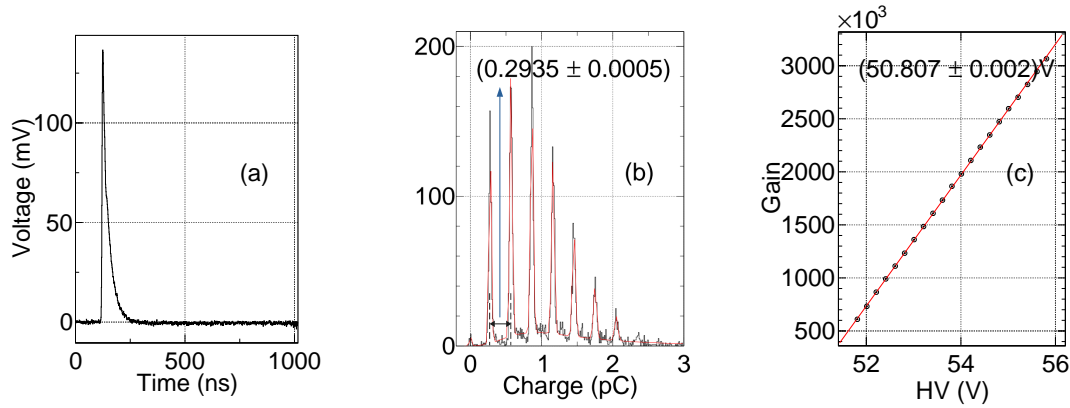

Figure 5: (a) Raw SiPM signal, (b) Charge distribution at $V_{bias} = 54$ V and (c) Calibration plot for measuring V_{br} and dG/dV for one of the SiPMs.

The distribution is fitted with the function :

$$f(y) = Landau(y) + \sum_{n=0}^{N-1} A_n \times e^{-\frac{(y - n\mu)^2}{2n\sigma^2}} \quad (2)$$

where N is the number of photoelectron (p.e.) peaks, A_n is the peak height, μ is the average gap between the consecutive photoelectron peaks and σ is the gaussian width of p.e. peak. The average gap between the consecutive p.e. peaks (μ) is measured from the fit and gain is calculated as follows :

$$Gain(G) = \frac{\mu}{(1.6 \times 10^{-19})C}$$

where $(1.6 \times 10^{-19})C$ is the elementary charge. The data is collected for five different values of bias voltage (V_{bias}). The testing with LED system as well as the noise data collection are done at room temperature ($25^\circ C$) and the temperature was recorded. The gain versus V_{bias} is plotted and fitted with a linear function as shown in Fig. 5c. From the linear fit, the slope is a measure of change in gain with respect to change in bias voltage i.e. dG/dV and the ratio of intercept to slope is a measure of V_{br} and is estimated for each of these SiPMs.

5 Summarised Results

Fig. 6 shows the dG/dV and V_{br} values for all 3488 SiPMs. A total of three bands are observed for dG/dV and V_{br} measurements corresponding to the different SiPMs. The observed V_{br} values are consistent with the V_{br} values given by Hamamatsu, at 25°C . The majority of the SiPMs are having dG/dV values $\sim 6.8 \times 10^5$. It is observed that one of SiPMs has low gain i.e. 5.1×10^5 and one has a physical damage. It is clear that all except two SiPMs (one with low gain and the other with physical damage) are suitable for the CMVD purpose.

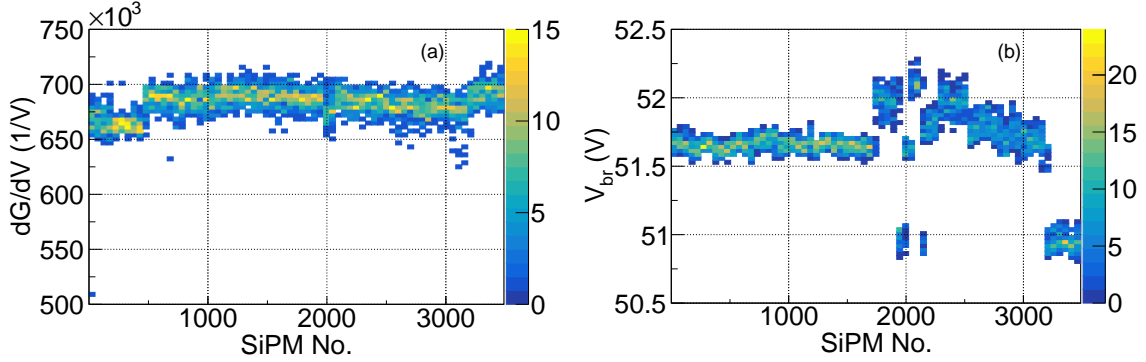

Figure 6: (a) The variation in gain with respect to bias voltage (dG/dV) versus SiPM number and (b) V_{br} versus SiPM number at room temperature (25°C).

Another important parameter is the noise rate of the SiPM. Thus, along with LED calibration, noise data is collected using a random trigger at $V_{bias} = 54\text{V}$. Fig. 7 shows the noise rate of SiPMs at a threshold of 0.5 pe. The noise rates are within the tolerable range as per previous studies [1].

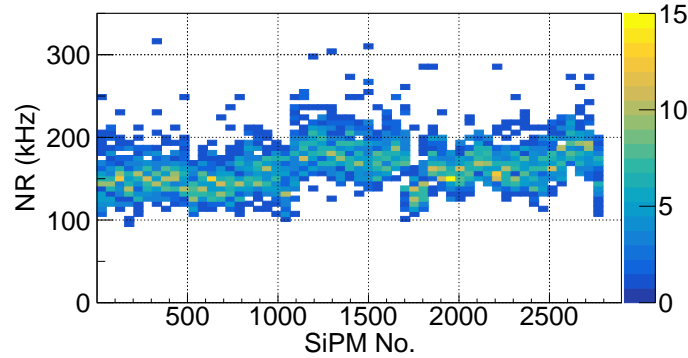

Figure 7: Noise rate (at 0.5 pe threshold) versus SiPM number.

Fig. 8a and Fig. 8b shows the correlation for dG/dV and V_{br} with the noise rate respectively. No correlation is observed for these parameters with the noise rate.

6 Conclusion

All the SiPMs required for the CMVD installation have been tested using LED calibration method. The V_{br} varies from 50.7V to 52.3V and matches with the specification given by Hamamatsu, at 25°C . The spread in dG/dV is $1.2 \times 10^4 (1/V)$. The overall spread in noise rate at 0.5 p.e. threshold is 26.8 kHz for $V_{ov}=3\text{V}$. Out of a total of 3488 SiPMs, there are only two

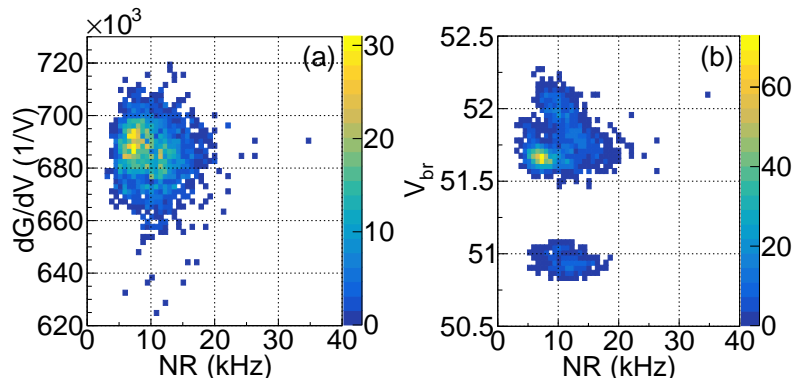

Figure 8: Correlation between (a) dG/dV and the noise rate (at 1.5 pe threshold) and (b) V_{br} and the noise rate (at 1.5 pe threshold).

exceptions i.e. one SiPM with low gain and one SiPM with physical damage. All other SiPMs satisfy the gain requirement as well as the noise tolerance level for the CMVD operation.

Acknowledgements

We would like to thank Darshna Gonji, Santosh Chawan and Vishal Asgolkar for providing help for the experimental setup.

References

- [1] Mamta Jangra et al., *Characterization of Silicon-Photomultipliers for a Cosmic Muon Veto detector*, *Journal of Instrumentation* **16**, (2021), doi:<https://doi.org/10.1088/1748-0221/16/11/P11029>.
- [2] HAMAMATSU, *MPPC datasheet*, doi:<https://www.hamamatsu.com/eu/en/product/type/S13360-2050VE>
- [3] Mamta Jangra et al., *Qualification study of SiPMs on a large scale for the CMVD experiment*, *Journal of Instrumentation* **17**, (2022), doi:<https://doi.org/10.1088/1748-0221/17/07/P07019>.