TCAD Simulation and Design Optimization of Radiation Hard n-MCz and n-Fz Si Microstrip Detector for the HL-LHC

Balwinder Kaur^a, Shilpa Patyal^a, Nitu Saini^a, Puspita Chatterji^a, Ajay K. Srivastava^{a,*}

^aDepartment of Physics, University Institute of Sciences, Chandigarh University, Gharuan-Mohali, Punjab, 140413, India.

E-mail: kumar.uis@cumail.in

ABSTRACT: A radiation hard Si detector is used in the new CMS tracker detector at HL-LHC. It has been observed that n-MCz and n-Fz Si as a material can be used for the Si micro strip detector. The detector design for this material should be simulated and optimized to get high CCE. In order to understand the charge collection behavior of the n-MCz/n-FzSi detector, it is required to simulate and compare the radiation damage effects in the mixed irradiated n-MCz Si and neutron irradiated n-FzSi micro strip detector equipped with metal overhang and multiple guard rings.

In this paper, we have done analysis and optimization of the radiation hard n-MCz Si/n-Fz Si strip detector design for the HL-LHC experiment in order to get high CCE.

KEYWORDS: *n-Fz/MCz* Si microstrip detector; TCAD simulation; Bulk damage; Full depletion voltage; Leakage current; CCE; Mixed irradiation.

* Corresponding author. Tel.: +91-8400622542; e-mail: kumar.uis@cumail.in

Contents

1. Introduction	1
2. Hamburg penta Trap Model (HPTM) for Proton irradiation in n-Fz Si strip detector and four level deep trap & mixed irradiated radiation damage model for n-MCz Si strip detector.	
2.1 Silicon strip detector model and SRH calculations	2
2.2 SRH calculation for full depletion voltage and generation current for n-MCz Si Strip detector.	5
2.3 Hamburg Penta Trap model (HPTM) for proton radiation damage effect in n-Fz thin/thick Si strip detector.	
3. Results and Discussions	6
3.1 Full depletion voltage and leakage current obtained using SRH calculation for n-Fz/n-MCz thick and thin Si Strip Detector.	
	6
4. TCAD simulation of n-MCz and n-Fz Si Microstrip Detector for the HL-LHC	
4.1 Electric Field in Mixed Irradiated n-MCz and proton irradiated n-Fz Thin Si Strip Detector	
5. Conclusion	7

1. Introduction

Radiation damage of the silicon strip detectors in upcoming hadron collider poses a major issue for its reliable operation for the long-term of the experiment. The combined radiation damage effects in the Si strip detectors in the new Compact Muon Solenoid (CMS) tracker at the High-Luminosity Large Hadron Collider must be investigated (HL-LHC) [1]. p-Si detectors exhibit good performance for the new CMS Tracker at HL-LHC experiments in the CERN RD50 European collaboration. [2]. The n-MCz (Magnetic Czochralski) Si material may be a good choice for the p-Si strip detector. [3-6]. As a result, radiation damage effects in thin p-Si in n-MCz Silicon (Si) microstrip detectors must be investigated. [3-6]. It was necessary to examine the macroscopic electrical performances of the p-Si in n-MCz Si strip detectors for the new CMS tracker in order to design, develop, and optimise detectors for the HL-LHC investigations. The macroscopic and microscopic performance of these Si strip detectors measured using Current-Voltage (I/V), Capacitance-Voltage (C/V), Thermally Stimulated Current (TSC), Deep Level Transient spectroscopy (DLTS), Transient Current Technique (TCT) and Alibaba system SL, Barcelona, Spain set up.

Within the CERN RD50 collaboration, a few detector groups have developed two/three deep traps radiation damage models for p-type semiconductor (SFz) material. For the bulk of the SFz (Si) detector, the model showed good observations of the experimental and simulation result for the fluencies of the order of $1 \times 10^{15} n_{eq}/cm^2$ 1 Mev equivalent neutrons [7]. The n-MCz four deep trap model has been developed to simulate the radiation damage effects in mixed irradiated detectors up to $8 \times 10^{14} n_{eq}/cm^2$ 1 Mev equal neutrons [7]. This work presents SRH calculation for the Full Depletion Voltage and leakage current for the n-Fz/n-MCz thick/thin silicon strip

detector. In this work we have also used Hamberg Penta Trap Model [8] for proton radiation damage effect in n-Fz Silicon thin/thick strip detector and mixed irradiated four level deep trap model in nMCz thin/thick Si strip[7] detector.

The paper has discussed in three sections; section 2 Hamburg Penta Trap Model (HPTM) [8] for Proton irradiation in n-Fz Si strip detector and four level deep trap mixed irradiated radiation damage model [7] for n-MCz silicon strip detector, Schockley Read Hall (SRH) calculations for the E(30K), V3, Ip, H220 and CiOi. Section 3 elaborates the results and discussion on the extrapolated values on the full depletion voltage and leakage current for mixed irradiated n-MCz thin/thick silicon strip detector and Proton irradiated n-Fz thin/thick Silicon strip detector. In section 4 we did the TCAD simulation to get the electric field behaviour of n-Fz/n-MCz silicon strip detector.

2. Hamburg Penta Trap Model (HPTM) for Proton irradiation in n-Fz Si strip detector and four level deep trap mixed irradiated radiation damage model for n-MCz Si strip detector

In this section, we have used the Hamburg Penta Trap Model (HPTM) for proton irradiation in n-Fz strip detector and four level deep-trap mixed irradiation model for n-MCz Silicon strip detector for the radiation damage analysis in nFz , and nMCz Si strip detector for the HL-LHC.

2.1 Silicon strip detector model and SRH calculations

A rectangular cell of $0.0625 \text{ cm}^2 \times 300/200 \mu\text{m}$ n-MCz Silicon strip detector model is used for the SRH calculations (see Figure 1) and the device and process parameters of the detector are shown in (Table 1). The effective doping concentration, N_{eff} , and generation leakage current, I_{gen} at full depletion voltage, V_{FD} can be calculated by the SRH theoretical expression [5], where symbols are having their usual meaning. Figure 1 shows n-MCz/n-Fz silicon strip detector/PAD diodes irradiated with mixed irradiation on which a high positive voltage V_0 is applied on the n^+ side and p^+ is at ground. Device simulations have been performed with ATLAS TCAD device simulator [9]. The following physical models have been used for numerical simulation: these are Shockley–Read–Hall recombination, FLDMOB, CONMOB, Band gap narrowing, Trap Assisted Model (Hurks Model). Figure 2 show the proposed multiple guard rings layout for n-MCz Silicon Strip detector.

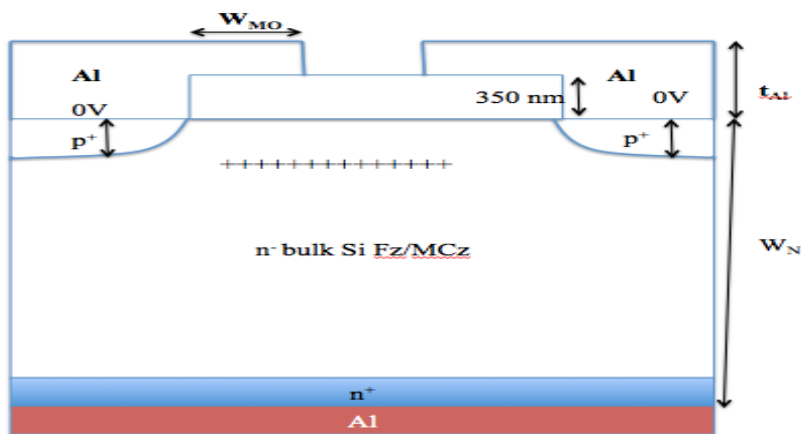

Figure 1. Cross-section of the $0.0625 \text{ cm}^2 \times 200/300 \mu\text{m}$ n-Fz/n-MCz Si strip detector model used in the present study for SRH/ calculations and TCAD device simulation.

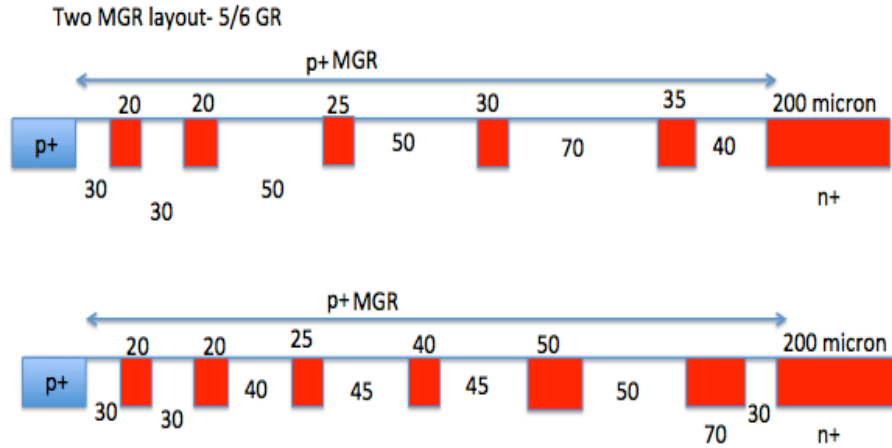

Figure 2. Multiple Guard Rings Layout for the n-Mcz Silicon Strip Detector (Proposed)

Table 1. Device and process parameters of n-MCz/n-Fz SiliconStrip detector.

S.No.	Physical parameters	Values
1.	Doping concentration (N_D)	$5 \times 10^{12} \text{ cm}^{-3}$
2.	Oxide +nitride thickness (t_{ox})	$0.3+.05 \mu\text{m}$, nitride added to prevent physical damage on the interface surface
3.	Junction Depth (X_j)	$1 \mu\text{m}$
4.	Device depth (W_n)	$200/300 \mu\text{m}$
5.	Fixed oxide charge (Q_f)	$1.5 \times 10^{12} \text{ cm}^{-2}$

2.2 SRH calculation for Full Depletion voltage and generation current for n-MCz Si Strip detector.

By using the Shockley Read Hall (SRH) recombination formula the effective doping concentration (N_{eff}) /full depletion voltage (V_{FD}) and the leakage current (I_L) can easily be calculated;

$$N_{eff} = N_D + \sum n_T^{donor} - \sum n_T^{acceptor} \quad (1)$$

$$\text{Here, } n_T = N_T \frac{e_{n,p}}{e_n + e_p} \quad (2)$$

Where

$$e_p = C_p N_V \exp \frac{-E_t - E_V}{kT}$$

$$e_n = C_V N_C \exp \frac{E_t - E_C}{kT}$$

Here, N_D is the doping concentration, n_T is the steady state occupancy of defect level, N_T is the defect concentration, $e_{n,p}$ is the emission rate of electron or holes, $C_{n,p}$ is the capture coefficient of electron or holes, V_{th} is the thermal velocity.

After calculating the effective doping concentration, the V_{FD} can be calculated by using the formula;

$$V_{FD} = \frac{W_N^2 N_D q}{2 \epsilon_{Si}} \quad (3)$$

Here, W_N is the thickness of the detector and ϵ_{Si} is the dielectric constant of silicon.

By using Shockley Read Hall recombination formula the generation leakage current (I_L) can be calculated;

$$I_L = qAd \left(\sum n_T^{\text{acceptor}} e_n + \sum n_T^{\text{donor}} e_p \right) = \frac{q n_i A W_N}{\tau_g} \quad (4)$$

Here, I_L is generation leakage current, q is elementary charge, A is the area of the detector, d is the thickness of the detector, n_i is the intrinsic carrier concentration and τ_g is the generation lifetime.

Current damage constant (α) can be calculated by using the formula:

$$\alpha = \frac{A}{\phi_{eq} \times V} \quad (5)$$

Here, α is current-damage constant, ϕ_{eq} is equivalent fluence and V is the volume of the detector.

2.3 Hamburg Penta Trap model for proton radiation damage effect in n-Fz thin/thick Si strip detector

In this paper, we have used Hamburg Penta Trap model (HPTM) for proton radiation damage effect (See Table.2) for the radiation damage analysis in proton irradiated in n Fz Si Strip Detector and a Four Level Deep Trap Mixed Irradiated Radiation Damage Models [7] in mixed irradiated n-type MCz Si Strip Detector.

Table 2 Hamberg Penta Trap Model for Proton Irradiation

Defect	Type	Energy	g_{int} (cm^{-1})	σ_n (cm^2)	σ_p (cm^2)
E30K	Donor	$E_C - 0.1$ eV	0.0497	2.300E-14	2.920E-16
V₃	Acceptor	$E_C - 0.458$ eV	0.6447	2.551E-14	1.511E-13
I_p	Donor	$E_C - 0.545$ eV	0.4335	4.478E-15	6.709E-15
H220	Donor	$E_V + 0.48$ eV	0.5978	4.166E-15	1.965E-16
CiOi	Donor	$E_V + 0.36$ eV	0.3780	3.230E-17	2.036E-14

3. Result and Discussion

In this section, we have used the SRH calculations and TCAD device simulation for the CCE comparison of the n-Fz/n-MCz thick and thin radiated Strip Detector.

3.1 Full depletion voltage and leakage current obtained after the SRH Calculation for n-Fz/n-MCz thick and thin Si Strip Detector.

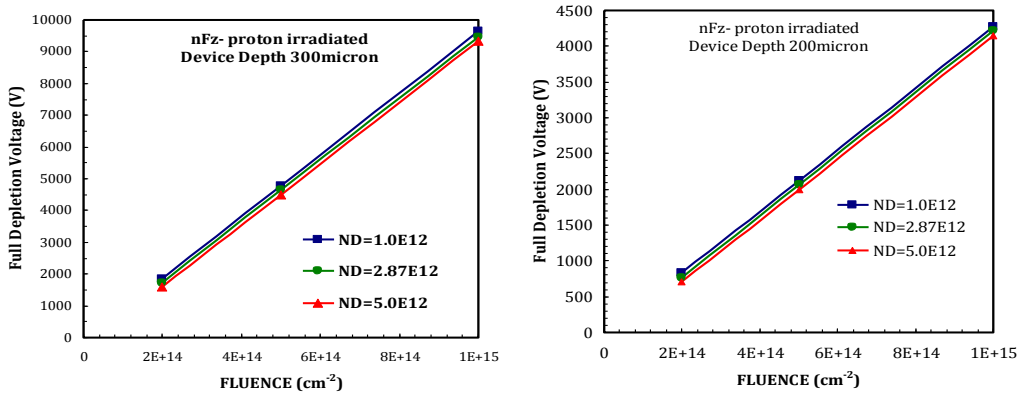

Figure 3. (a) Full depletion voltage as a function of the Fluence in Proton Irradiated n-Fz thick Silicon (Si) Strip Detector. (b) Full depletion voltage as a function of the Fluence in Proton Irradiated n-Fz thin Silicon (Si) Strip Detector.

Hamburg Penta Trap Model (HPTM) model can reproduce the experimental data in n in p, In figure 3 a we used in 300 μm n-Fz proton irradiated Si strip detector as shown in [5], V_{fd} estimated from SRH calculations [8] and decreases with increasing doping concentration Significant increase in V_{fd} with the proton radiation fluences (Φ_{eq} , n (fluence), equivalent to 1 MeV neutron) in n-Fz detector using HPTM model [5].

In figure 3 (b), it is shown that HPTM model can used to get V_{fd} in 200 μm n-Fz proton irradiated Si strip detector, 50% less V_{fd} have been obtained in 200 μm n-Fz proton irradiated Si strip detector than 300 μm strip detector irradiated by protons.

It is also observed from the figure significant increase in V_{fd} using HPTM SRH calculations in the proton irradiated detector by 24 GeV/c protons, HPTM needs to tune the parameters to reproduce the macroscopic measurements for the good agreement in the experimental data and simulation data on n-Fz Strip detector/diodes too using silvaco TCAD.

For the $5 \times 10^{12} \text{ cm}^{-3}$ doping of n-Fz bulk, less full depletion voltage (705V) obtained for the fluence of $2 \times 10^{14} \text{ cm}^{-2}$ than other fluencies.

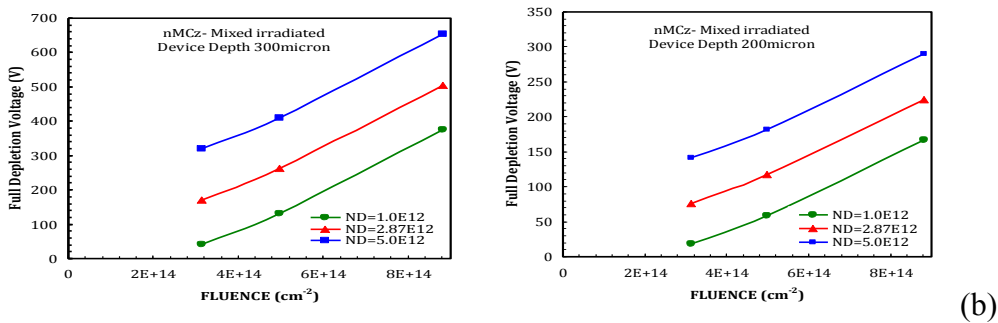
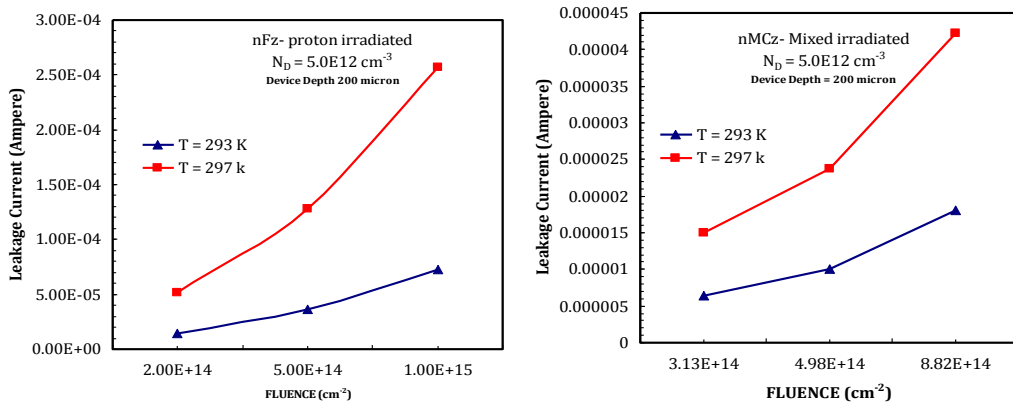

Figure 4 (a). Full Depletion Voltage as a function of the Fluence in Mixed Irradiated n-MCz Thick Si Strip Detector (b) Full Depletion Voltage as a function of the Fluence in Mixed Irradiated n-MCz Thin Si Strip Detector.

It is observed from the figure 4 (a) that V_{fd} increases with the mixed irradiated fluences for the three doping concentrations in thick n-MCz Si strip detector, less full depletion voltage obtained than other n-Fz proton radiated detectors, less V_{fd} obsded due to the compensation of the deep traps in n-MCz as compared to n-Fz Si strip detector.

Full Depletion Voltage as a function of the Fluence in Mixed Irradiated n-MCz Thin Si Strip Detector is shown in figure 4 (b). It is depicted from the figure that V_{fd} increases with the mixed irradiated fluences for the three doping concentrations in thin n-MCz Si strip detector too, less full depletion voltage obtained than 300 μm Mcz Si strip detectors, less V_{fd} observed in the $1 \times 10^{12} \text{ cm}^{-3}$ n-MCz bulk doping, although for comparison and isolation in between strips (n+ in p detector) of the effect on the macroscopic performance and E-field distribution, have taken high doping $5 \times 10^{12} \text{ cm}^{-3}$ in the n-MCz strip detector design that is giving $< 300 \text{ V}$ full depletion voltage. Thin n-MCz Si strip detector can be operated at an applied bias of 500 V.



(a) **Figure 5 (a).** Leakage Current as a function of the Fluence in Proton Irradiated Fz thin Si Strip Detector at two Temperatures **(b)** Leakage Current as a Function of the Fluence in Mixed Irradiated n-MCz Thin Si Strip Detector at two Temperatures.

Figure 5 (a) shows that Leakage Current as a function of the Fluence in Proton Irradiated Fz thin Si Strip Detector at two Temperatures. From the figure it is observed that the leakage current increases with fluences at 293 (RT), and 297 K (RT+4K) that shows the experimental results as per our work [3].

Leakage Current as a Function of the Fluence in Mixed Irradiated n-MCz Thin Si Strip Detector at two Temperatures is shown in figure 5 (b). It is evident from the figure that Leakage current increases with fluences at 293 (RT), and 297 K (Rt+4K) that shows the experimental results as per [8]. It is also observed from the figure that less leakage current showed in the n-Mcz Si strip detector than n-Fz strip detector at two temperatures (292 K, 297 K).

4. TCAD simulation of n-MCz and n-Fz Si Microstrip Detector for the HL-LHC

In this section, the detector model (See Figure.6) is simulated using ATLAS Silvaco and the results are shown for the CCE comparison of the proton irradiated n-Fz and mixed irradiated n-MCz thick and thin radiated Strip Detector.

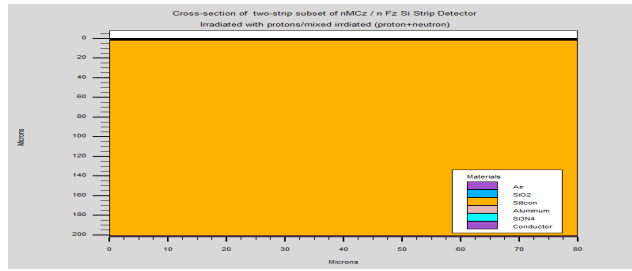

Figure 6. Cross-section view of two strip subset of n-MCz/n-Fz Strip Detector irradiated with protons/mixed irradiated (proton+neutrons).

4.1 Electric Field of Mixed Irradiated n-MCz Thin Si Strip Detector

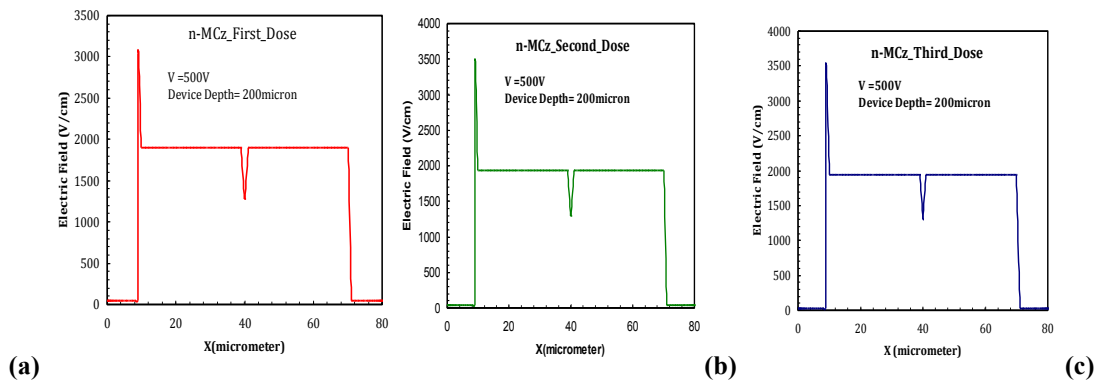

Figure 8. Electric Field of Mixed Irradiated n-MCz Thin Si Strip Detector for (a) $3.13 \times 10^{14} \text{ cm}^{-2}$ (b) $4.98 \times 10^{14} \text{ cm}^{-2}$, (c) $8.82 \times 10^{14} \text{ cm}^{-2}$.

It is observed from the figure 8 (a) that low E-field obtained in the base region of the detector, and E-field gutter observed in the Centre of the detector ($X=40 \mu\text{m}$, cut $X=2.3 \mu\text{m}$). It is observed from the figure 8 (b), and (c) that E-field increases at curvature of junction and slightly increase at E-field gutter, $X=40 \mu\text{m}$

With an increasing mixed doses, E-field at curvature of junction saturates and at E-field gutter, $X=40 \mu\text{m}$ too E-field gutter can be cause of trapping of charge carrier.

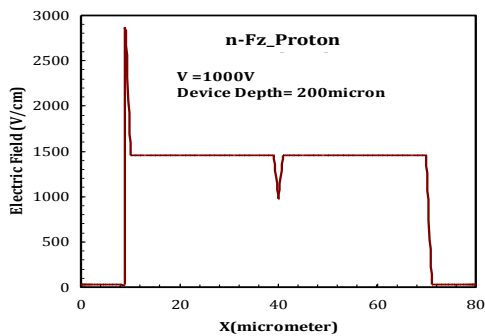

Figure 9. Electric Field of Proton Irradiated n-Fz Thin Si Strip Detector for $2 \times 10^{14} \text{ cm}^{-2}$

It is observed from the figure 9 less E-field at curvature of junction and in the base region of the detector, and also less E-field at E-field gutter than mixed irradiated n-MCz Si Strip detector. High CCE expected in thin n-MCz than n-Fz Si strip detector, traps modifying E-field in the base region of the detector.

5. Conclusion

In this paper we explained SRH calculation of full depletion voltage and leakage current for n-Fz/n-MCz thick/thin strip detector. Hamberg penta trap model used for proton irradiated n-Fz strip detector and four level deep trap mixed irradiated radiation damage model for n-MCz silicon strip detector. The V_{FD} is the main macroscopic parameter that can determine the space charge behavior of the mixed irradiated detectors. It is observed after the SRH calculations the Full Depletion (V_{FD}) voltage of n-MCz thin silicon strip detector is less as compared to the thin n-Fz silicon strip detector.

. Whereas, the generation leakage current in the mixed irradiated detectors can have the uncertainty of 10-30 %, which can be due to experimental measurements. Therefore after the SRH calculation leakage current of the n-MCz thin silicon strip detector is less as compared to the thin n-Fz silicon strip detector.

It is also revealed from the TCAD simulation result 200 μm n-MCz thin Si microstrip detector consists high Charge Collection Efficiency(CCE) expected as compared to n-Fz. MGR design is also proposed for the n-MCz Si strip detector. Therefore, the radiation hard thin n-MCz Si microstrip detector for the new CMS tracker detector system can be designed and optimized for the HL-LHC experiments.

References

- [1] A. Dierlamm, "The CMS Outer Tracker Upgrade for the HL-LHC", *Nuclear Inst. and Methods in Physics Research, A* 924 256-261 (2019) .
- [2] M. Moll, "Displacement damage in silicon detectors for high energy physics", *IEEE Trans. Nucl. Sci.* 65, 1561-1582 (2018) .
- [3] CMS collaboration, "1-D plot covering CMS tracker, showing FLUKA simulated 1 MeV neutronequivalent in Silicon including contributions from various particle types", *CMS-DP-2015-02* .
- [4] G. Kramberger, V. Cindro, I. Dolenc, I. Mandic, M. Mikuz, M. Zavrtanik, "Performance of silicon pad detectors after mixed irradiations with neutrons and fast charged hadrons", *Nucl. Instr. Methods Phys. Res. A* , 609 (2009) 142-148.
- [5] Ajay.K. Srivastava, "Si Detectors and Characterization for HEP and Photon Science Experiment: How to Design Detectors using TCAD Device Simulation", *Springer Nature Switzerland AG, Switzerland, ISBN:978-3-030-19530-4, 2019* .
- [6] Ajay.K. Srivastava, D.Eckstein, E. Fretwurst, R.Klanner, G. Steinbruck, "Numerical Modelling of Si sensors for HEP experiments and XFEL", *Proceedings of Science, Detectors-RD09 Florence, Italy, 2009 (RD09)019* .
- [7] A. Sharma, N.Saini, S.Patyal, B.Kaur, A.K. Srivastava, "Performance characteristics of mixed Irradiated n-MCz thin Si microstrip detector for the HL-LHC experiments", *arXiv:2103.02318v1, 2021* .
- [8] Joern Schwandt, Eckhart Fretwurst, Erika Garutti, Robert Klanner, Christian Scharf, and Georg Steinbrueck "A new model for the TCAD simulation of the silicon damage by high fluence proton irradiation", *Sydney, NSW, Australia IEEE ISBN: 978-1-5386-8494-8, 2019* .
- [9] SILVACO Int, ATLAS 3D DEVICE Simulator, Santa Clara, CA, 2019.