

Learning for Advanced Motion Control

Tom Oomen

Eindhoven University of Technology, The Netherlands

t.a.e.oomen@tue.nl

Abstract—Iterative Learning Control (ILC) can achieve perfect tracking performance for mechatronic systems. The aim of this paper is to present an ILC design tutorial for industrial mechatronic systems. First, a preliminary analysis reveals the potential performance improvement of ILC prior to its actual implementation. Second, a frequency domain approach is presented, where fast learning is achieved through noncausal model inversion, and safe and robust learning is achieved by employing a contraction mapping theorem in conjunction with nonparametric frequency response functions. The approach is demonstrated on a desktop printer. Finally, a detailed analysis of industrial motion systems leads to several shortcomings that obstruct the widespread implementation of ILC algorithms. An overview of recently developed algorithms, including extensions using machine learning algorithms, is outlined that are aimed to facilitate broad industrial deployment.

Index Terms—Motion Control, Precision Mechatronics, Iterative Learning Control, Repetitive Control, Machine Learning

I. INTRODUCTION

Learning from data has led to impressive achievements in recent years, many of which cannot go unnoticed in everyday life. Computer algorithms are now able to successfully learn in many domains, including human language such as speech recognition and accurate translations, real-time pattern recognition from images, digital advertising, self-driving vehicles, and in games such as Atari and Go [49]. The key enabler is the availability of large amounts of data in addition to ubiquitous and scalable computation and software.

In sharp contrast, high-tech machines are often produced and installed with a pre-defined feedforward/feedback control algorithm, and their performance deteriorates over time due to wear, ageing, and varying environmental conditions such as temperature variations. Examples of such high-tech machines range from manufacturing machines such as lithographic wafer scanners [25], [6], 2D and 3D printers, and pick-and-place robots, to scientific instruments such as microscopes [2], and medical equipment such as CT scanners. Interestingly, these high-tech machines are prime examples of mechatronic systems, where control algorithms are typically implemented in a digital computer environment. Hence, abundant data becomes available during the lifetime of these machines, yet this is often not exploited to enhance their performance.

Iterative Learning Control (ILC) [34], [17], [5], [21] is a high-performance digital control strategy used to improve the performance of batch repetitive processes, by iteratively updating the command signal from one experiment to the next. Basically, ILC results in a command signal that can compensate for repeating components in the error signal, even if

imperfect plant knowledge is available. ILC learns by updating the command input by filtering measured error data. To achieve fast learning, the filter should approximate the inverse of the closed-loop system. To achieve safe and robust learning, the approximation error should be sufficiently small.

Many different ILC design frameworks have been developed and successful implementations have been reported. Design frameworks include frequency domain approaches [51], optimization-based ILC [53], [23], Arimoto-type ILC [3], and joint feedback and ILC design [46], [42]. Furthermore, theoretical aspects, e.g., convergence [20], are well-understood.

Although several ILC design frameworks are available, at present ILC is not yet broadly implemented as a standard industrial control component in advanced motion control of mechatronic systems. The aim of this paper is to provide a tutorial on ILC designs for advanced motion control in mechatronic systems, point out its shortcomings that obstruct widespread industrial deployment, and outline several recent developments that facilitate broad industrial deployment. These developments are described in detail in the references, and preliminary results of the case study appear in [37], [10].

II. FROM TRADITIONAL MOTION CONTROL TO LEARNING

A. Motion control

Precision mechatronics are essential for many industrial systems, including manufacturing machines and scientific instruments. Positioning systems are key subsystems that create the functionality in these machines. These subsystems are responsible for the motion that positions the product in the machine, e.g., the wafer in lithography, the substrate in printing, the sample in microscopy, and the mirror alignment in telescopes and lithographic optics.

Positioning systems are mostly mechatronic systems that contain many aspects, including mechanics, electronics, sensors, actuators, and thermal conditioning, see [36]. A key aspect is motion control, where sensor measurements are processed by a digital controller to generate inputs for the actuators.

Motion control often uses the architecture in Fig. 1. Here, G is the mechatronic system, including actuators, mechanics, and sensors. The goal is to track a reference r , i.e., minimize the error $e = r - y_j$. This is achieved through a feedback controller K and feedforward signal f_j . In addition, v_j is a disturbance.

B. Reference design

Motion systems have to track a reference trajectory r . In certain applications, the goal is to perform a point-to-point motion, e.g., pick-and-place machines, including wire-bonders

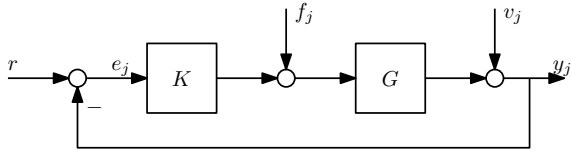

Fig. 1. Traditional motion control architecture.

and die-bonders [11], where the end-point accuracy is essential, see [12]. In other applications, e.g., printing systems and wafer scanners, the error should be small during constant velocity, see [40]. In both cases, r is designed as a 3rd or 4th order profile to ensure that actuator constraints are satisfied [30], see Fig. 2 for an example.

C. Feedback control

From Fig. 1, the error in task j is given by

$$e_j = S(r - Gf_j) - Sv_j, \quad (1)$$

where $S = \frac{1}{1+GK}$. In the case without feedforward, i.e., $f_j = 0$, then $e = S(r - v_j)$. A small error is then achieved by making S small at the frequencies where the power spectrum of r and v_j is large. Typical references r as described in Sec. II-B mostly have low-frequency content, hence S must be made small at low frequencies. Similarly, v_j has a certain power spectrum, and S must be made small at those frequencies. Shaping these closed-loop functions such as S while at the same time ensuring closed-loop stability is typically done using loop-shaping. Loop-shaping for motion systems typically leads to Proportional-Integral-Derivative (PID) type controllers, e.g., [38]. A typical constraint herein is the Bode sensitivity integral, which states that sensitivity reduction at low frequencies necessarily leads to an amplification at high frequencies, see [50, Fig. 3 and 4]. This relates to causality: the feedback controller is always too late, since it only takes action if the error is nonzero.

D. Feedforward control

The aim of feedforward is to compensate for reference-induced error signals before these affect the system. In view of (1), the goal of feedforward is to pick f_j such that $r - Gf_j$ is minimized. This is achieved by selecting $f_j = G^{-1}r$. Determining the inverse of G is typically done by bridging first-principles system knowledge with data-driven tuning. In particular, typical motion systems are of the form [19]

$$G = \underbrace{\frac{1}{ms^2}}_{\text{rigid-body mode}} + \underbrace{\sum_{i=N_{rb}+1}^{n_s} \frac{r_i}{s^2 + 2\zeta_i\omega_i s + \omega_i^2}}_{\text{flexible modes}}, \quad (2)$$

hence in the low-frequency range, where r has most of its energy, the system is approximately a double integrator, i.e., $\frac{1}{ms^2}$. As a consequence, G^{-1} is approximated as ms^2 , leading to $f_j = ms^2r$. Since the inverse Laplace transform of s^2r is given by the acceleration profile \ddot{r} , $f_j = m\ddot{r}$. The parameter m is tuned using measured data, see [38], [25]. Note that (2) also gives rise to other feedforward parameters such as snap [38].

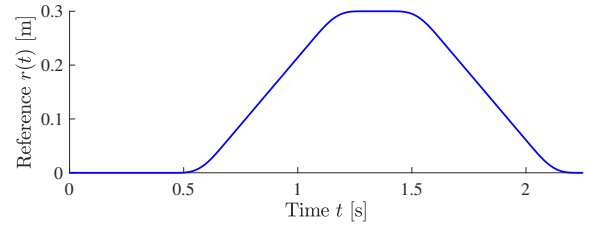

Fig. 2. Typical reference r .

E. Learning from data and requirements

Both feedback and feedforward control are used as standard components for motion control of precision mechatronics. However, in practice always an error remains, which is measured directly in the system. Indeed, data is abundantly available in present-day mechatronic systems, yet this information is still far from fully exploited. Indeed, sensors in mechatronic systems are often used for feedback control, which typically only make use of real-time position and velocity information in PID-type controllers. The aim here is to fully exploit all data from past and already completed tasks to achieve control to the limit of the predictable behavior of mechatronic systems.

Learning in mechatronic systems imposes several unique requirements, since it involves interactions with the real world. The following requirements are considered throughout.

- 1) Learning should be fast, since machines require experiments in real-time. In addition, fast adaptation is useful in case of varying conditions, e.g., time variations over different periods, e.g., day/night and seasonal changes.
- 2) Learning should be safe and use operational data, since dedicated experiments may induce production loss and even damage of the machine.

This paper addresses three questions. First, what can learning achieve for a specific system? Second, how to achieve fast and safe learning convergence using operational data? Third, why is learning not ubiquitous in industrial motion control? These questions are addressed in the forthcoming sections.

Remark 1: Throughout, the system resets after each task, leading to iterative learning control with both a time and task variable, see Fig. 4. In case of continuous operation, repetitive control is obtained, for which a similar design framework is available yet different analysis tools are required, see [31], [7].

III. WHAT DOES ILC HAVE TO OFFER FOR A SPECIFIC SYSTEM?

A main advantage of ILC is that the achievable performance can be estimated before actually implementing ILC, providing the user with an insightful performance lower bound. This is illustrated using experiments on the desktop printer in Fig. 3. The goal is to position the carriage that contains the printheads. The input of the system is the voltage signal to the motor that drives the carriage through a rubber belt. The output is the position of the carriage, which is measured using a linear encoder. Throughout, a PD feedback controller is implemented.

The main idea is that ILC can compensate the reproducible and hence predictable part of the error. To determine this part,

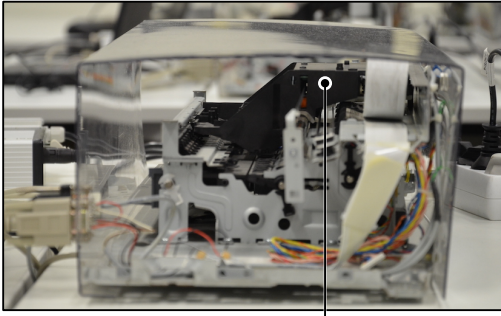

Carriage with printhead

Fig. 3. Printer system with repeating tasks.

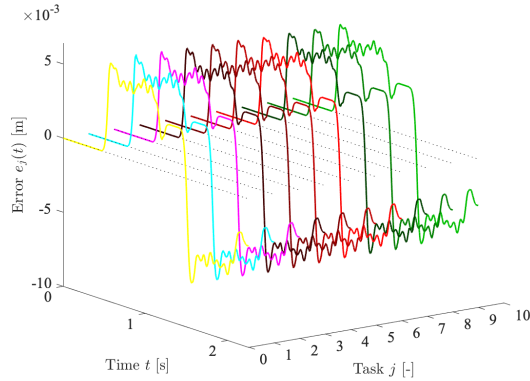

Fig. 4. Measured error signal for ten tasks j using only feedback control.

ten identical tasks have been performed using only feedback control, corresponding to printing ten lines on a sheet of paper. The resulting error signals are depicted in Fig. 4. Clearly, the error is highly reproducible. To further analyze the error signal, let the error in task j be denoted $e_j(t)$, $j = 0, \dots, n_{\text{exp}} - 1$, where $n_{\text{exp}} = 10$ denotes the number of tasks.

Next, compute the sample mean of the error signal

$$m_e(t) = \frac{1}{n_{\text{exp}}} \sum_{j=0}^{n_{\text{exp}}-1} e_j(t). \quad (3)$$

For the repeated tasks in Fig. 4, the sample mean m_e is depicted in Fig. 5, together with the ten realizations j .

Clearly, the part m_e is easy to predict and should be possible to compensate by designing f_j in Fig. 1. By subtracting the sample mean m_e from the realizations $e_j(t)$, the non-reproducible part remains, see Fig. 6. This is the residual error that cannot be compensated directly using ILC. Typically, this residual error due to non-reproducible disturbances is at least an order of magnitude smaller compared to m_e , see Fig. 6.

Summarizing, an estimate of the potential performance increase of ILC is obtained, i.e., reducing the error from Fig. 5 to Fig. 6. The remaining question is how to actually achieve this, which is investigated in the forthcoming section.

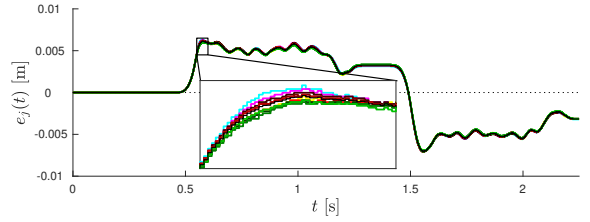

Fig. 5. Measured error signal for ten tasks j using only feedback control of Fig. 4, together with sample mean $m_e(t)$ (solid black). The main idea is that the reproducible part $m_e(t)$ of the error can be easily predicted and hence compensated.

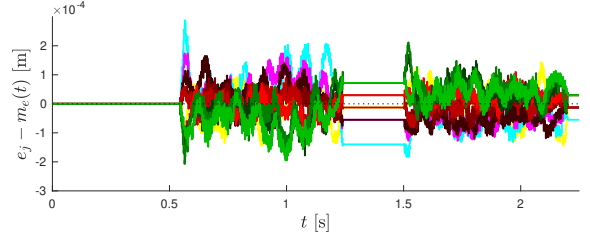

Fig. 6. Measured error signal for ten tasks j using only feedback control of Fig. 4, where the sample mean m_e of Fig. 5 has been subtracted. The remaining non-reproducible part of the error remains, which typically cannot be compensated using ILC. This is the order of magnitude of the error that ILC will be able to obtain, which is substantially less than the error using feedback only.

Remark 2: In Fig 4-6, an analysis has been done using feedback only. A similar approach can be pursued in case feedforward is already implemented.

Remark 3: The reproducible part, i.e., the sample mean m_e in Fig. 5, can be directly compensated using ILC. Clearly, the residuals contain non-repeating parts that can be mitigated using feedback, see [57] for details.

IV. FREQUENCY DOMAIN ILC FOR PRECISION MECHATRONICS

A. A basic approach for fast learning from past data

The main idea in ILC is to learn from past measured error signals. Suppose that an initial task has been completed. Consider for example task $j = 0$ in Fig. 4, where a feedback controller is used and feedforward $f_0 = 0$.

After each task j , the ILC algorithm should generate a command signal for the next task f_{j+1} . Hence, command signal f_1 is determined prior to starting task 1, i.e., based on measured data in task 0. Assume for the moment that the same task is performed, and that only access to measured error signal e_0 is available. In addition, the disturbance v_j is zero.

This leads to the following problem: determine f_1 based on the measured signal e_0 , such that e_1 is small. Note from Fig. 7 that

$$e_0 = S r \quad (4)$$

$$e_1 = S r - G S f_1. \quad (5)$$

Next, the first key step is to substitute (4) into (5), leading to

$$e_1 = e_0 - G S f_1. \quad (6)$$

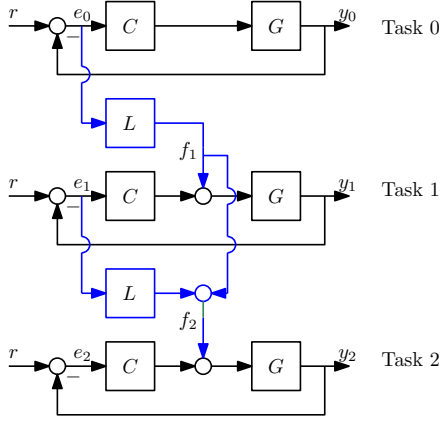

Fig. 7. Learning from past tasks.

The second key step is to pick f_1 as a filtered version of e_0 , see also Fig. 7, i.e., according to the update law

$$f_1 = Le_0. \quad (7)$$

In this case,

$$e_1 = (1 - GSL)e_0. \quad (8)$$

Next, $e_1 = 0$ is obtained by $(1 - GSL) = 0$. This is achieved by $L = (\widehat{GS})^{-1}$, where \widehat{GS} is a model of the true system G .

In practice, model errors, i.e., $\widehat{GS} \neq GS$ may lead to a situation where f_1 leads to an error signal e_1 that is not exactly zero. This leads to the concept of iterative learning control:

$$f_{j+1} = f_j + Le_j. \quad (9)$$

The intuition is as follows: if f_1 already leads to $e_1 = 0$, then in the next task $j = 2$ this command input is retained, i.e., $f_2 = f_1$. Otherwise, a small correction Le_1 is added to f_1 .

B. The need for robustness for safe learning

1) *Implementation of the learning update:* Implementation of the learning algorithm (9) during ten tasks as in (4) leads to the error signal in Fig. 8. In the first tasks, i.e., $j = 1, 2, 3$, the error reduces. However, from task 4 onwards, the error starts to increase again. This is also clearly visible from Fig. 9, where the 2-norm of the energy is depicted. This is an undesired aspect, which needs further investigation.

2) *Convergence analysis:* The example in Sec. IV-B1 reveals that learning can lead to unbounded error signals. The main reason is that learning generates a feedforward signal in each task, see Fig. 7, yet leads to a feedback in the iteration domain. In particular, to analyze convergence, note from (5) that

$$e_j = Sr - GSLf_j. \quad (10)$$

Also, consider the extended learning update

$$f_{j+1} = Q(f_j + Le_j), \quad (11)$$

where (9) is recovered by setting $Q = 1$. By evaluating (10) for both j and $j + 1$, and using (11), this leads to

$$e_{j+1} = Q(1 - GSL)e_j + (1 - Q)Sr. \quad (12)$$

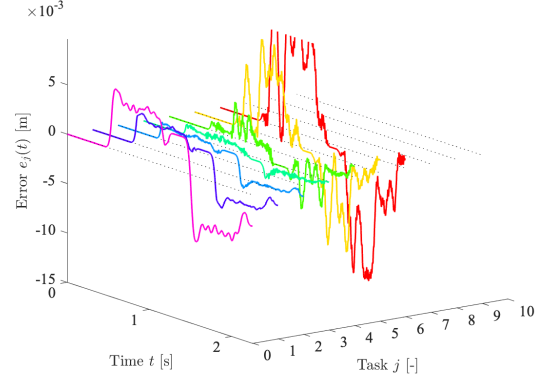

Fig. 8. Measured error signal for ten tasks j using the learning update (9). In the first three tasks, the error signal reduces, but after four tasks it starts to increase.

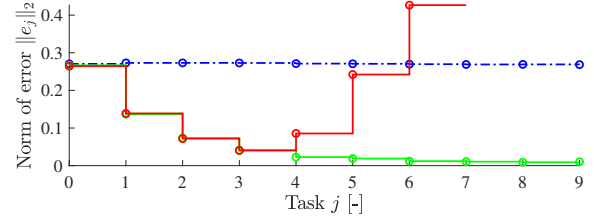

Fig. 9. Measured error signal for ten tasks j using feedback only (blue), the learning update (9) (red), learning update (11) (green).

The key question is whether the iteration (12) converges. The following theorem gives a decisive answer to this issue through a contraction mapping. Here, the notion of monotonic convergence is used, which is defined as follows.

Definition 1: The iteration (12) is monotonically convergent in the ℓ_2 norm if, for some $k \in [0, 1)$ and for all e_j ,

$$\|e_\infty - e_{j+1}\|_2 \leq k\|e_\infty - e_j\|_2. \quad (13)$$

Theorem 1: The iteration (12) is monotonically convergent in the ℓ_2 norm to a fixed point e_∞ and corresponding f_∞ if and only if

$$\|Q(1 - GSL)\|_{\mathcal{L}_\infty} < 1. \quad (14)$$

For a proof of Theorem 1, see [40, Theorem 2]. Here, the ℓ_2 norm of a signal x is defined as $\|x\|_2 = \sqrt{\sum_{t=-\infty}^{\infty} |x(t)|^2}$. Also, the \mathcal{L}_∞ norm for a single-input single-output system F is defined as $\|F\|_{\mathcal{L}_\infty} = \sup_\omega |F(e^{j\omega})|$, hence (14) is equivalent to the frequency domain test

$$|Q(1 - GSL)| < 1\forall\omega. \quad (15)$$

Note the resemblance of the \mathcal{L}_∞ norm with the commonly used \mathcal{H}_∞ norm. The key difference is that the \mathcal{L}_∞ allows for non-causal ILC algorithms, i.e., non-causal L and Q in (11). This is essential for ILC and does not require L and Q to be analytic outside the unit disc, as is explained in Sec. IV-B4.

The most important aspect for practical mechatronic systems is the fact that frequency response function measurements are

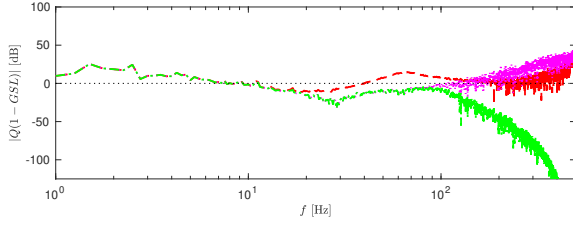

Fig. 10. Convergence condition (15) for the ILC iteration of Fig. 8 (dashed red). Next, (15) is verified for the new model, i.e., $1 - GSL^{\text{accurate}}$ (dotted magenta). Finally, robust monotonic convergence is guaranteed by inclusion of Q , leading to $Q^{\text{accurate}}(1 - GSL^{\text{accurate}})$ (dash-dotted green). In the latter case, the convergence condition is met for frequencies beyond 10 Hz. Below 10 Hz, the frequency response function is very noisy, and therefore discarded.

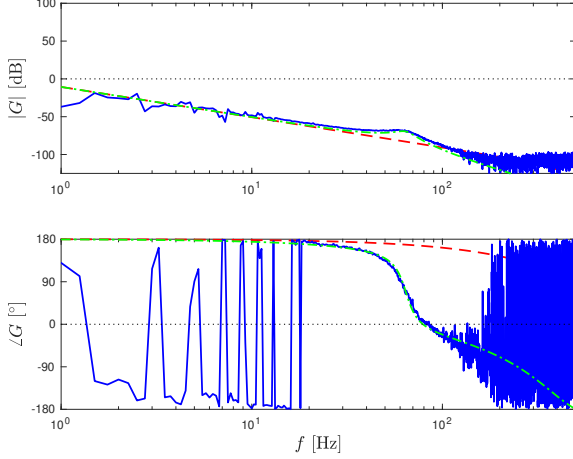

Fig. 11. Identified frequency response function of the printer system (solid blue), parametric model corresponding to Fig. 8 (dashed red), and improved parametric model corresponding to Fig. 12 (dash-dotted green).

fast, accurate, and inexpensive [32]. Interestingly, the choice $L = (GS)^{-1}$ in Sec. IV-A typically involves a parametric model, but condition (15) can be directly verified for a nonparametric frequency response function, possibly for a range of relevant operating conditions [32] or for a range of systems to address machine-to-machine variability.

Application of Theorem 1 to analyse the situation of Fig. 8 leads to the result in Fig. 10, where an identified frequency response function of the printer is used. Clearly, condition (15) is violated, hence the iteration (12) does not converge.

3) *Designing ILC for robust monotonic convergence:* To design a robust monotonically convergent ILC, the following design procedure is considered.

- 1) Determine a parametric model \widehat{GS} of GS and determine $L = (\widehat{GS})^{-1}$.
- 2) Determine Q such that $Q = 1$ for frequencies where $1 - GSL < 1$, and $|Q| < 1$ such that $|Q(1 - GSL)| < 1, \forall \omega$.

In view of the printer setup, i.e., Fig. 10, both L and Q are designed. To address Step 1, the model of the system is improved, see Fig. 11. In particular, the model corresponding to Fig. 8 only contains the rigid-body mode-shape in (2). The model is extended with a flexible mode, corresponding to the flexibility introduced by the belt mechanism, see Fig. 3.

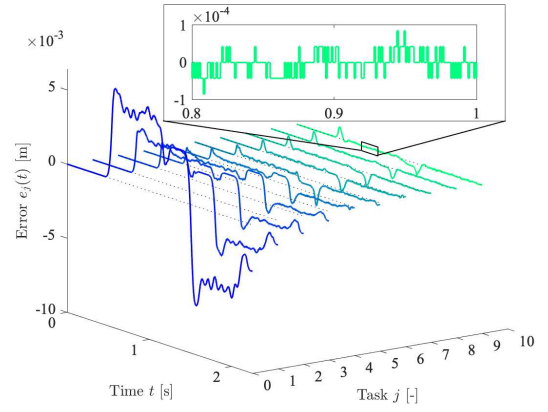

Fig. 12. Measured error signal for ten tasks j using the learning update (11) using L^{accurate} and Q^{accurate} of Fig. 10. The error reduces monotonically towards e_∞ for increasing j , achieving almost encoder resolution.

This leads to L^{accurate} , which already improves the convergence condition, see Fig. 10. Next, to guarantee convergence, Q^{accurate} is designed in Step 2, see Fig. 10. Note that Q should be chosen close to 1 to ensure high performance. Indeed, $Q \neq 1$ leads to an asymptotic error, which can be directly derived from (12) and (4) and $e_\infty = \lim_{j \rightarrow \infty} e_j$, leading to $e_\infty = \frac{1-Q}{1-Q(1-GSL)}e_0$.

The resulting L^{accurate} and Q^{accurate} are implemented on the system, see Fig. 12 for results. Clearly, the error is reduced substantially towards the encoder resolution. Hence, after 10 iterations it is already in line with Sec. III.

Remark 4: Many alternative ILC designs are available, e.g., Arimoto ILC, where L is designed as a proportional-derivative filter. A key advantage of the approach outlined here is its fast convergence in conjunction with a systematic design of robustness filters using non-parametric frequency response functions, which is particularly well suited for mechatronic systems. Note that the convergence results, including Theorem 1, can be directly applied to alternative ILC designs.

4) Implementation aspects:

- 1) One of the key benefits of ILC is the fact that it can generate non-causal signals in the time domain by appropriate design of L . Indeed, in case the system has a relative degree of at least two, feedback control is subject to the Bode sensitivity integral, see Sec. II-C. An example is the case where GS has strict delay, e.g., $GS = z^{-d}$. In this case, the optimal L is given by $L = z^d$, i.e., d samples preview. To see this, note that $e_j = Sr - z^{-d}f_j$, hence f_j is always delayed by d samples, which must be compensated by L , i.e., there must be an information flow to earlier time instants. Similarly, in many cases GS has non-minimum phase zeros, hence inversion may lead to unstable poles. Both cases motivate a non-causal design of L . For ILC, stable inversion techniques enable infinite preview, while \mathcal{H}_∞ preview control provides an optimal solution for the finite preview case [58].
- 2) Similarly, Q is designed in Step 2 of Sec. IV-B3 such that $|Q(1 - GSL)| < 1 \forall \omega$. Note that the phase of Q is does not

affect robustness, but negatively influences performance. Therefore, the phase is eliminated by filtering with a filter \tilde{Q} and its adjoint \tilde{Q}^* [13]. In this case, the convergence condition becomes $|\tilde{Q}^* \tilde{Q}(1 - GSL)| = |\tilde{Q}|^2 |1 - GSL|$.

- 3) ILC may lead to an amplification of measurement noise, which can be mitigated by a learning gain [40, Sec. 3].
- 4) In case the feedback controller K in Fig. 1 contains an integrator, then the inversion step in Step 1 in Sec. IV-B3 is troublesome. See [15, Sec. 6] for a solution.

V. TOWARDS INDUSTRIAL USE IN COMPLEX MECHATRONICS

The systematic ILC design framework for mechatronic systems in Sec. IV allows for a substantial performance improvement, still its full potential in industrial application is largely unexploited. The aim of this section is first to investigate industrial requirements for ILC algorithms. This reveals key reasons that have led to limited industrial adoption. In addition, an overview of recent developments that aim to facilitate their industrial deployment is provided.

A. Automated feedforward tuning for flexible tasks

Learning control can potentially compensate for all repeating disturbances, i.e., iteration-invariant disturbances that are identical for each task. Indeed, in Sec. IV, it has only been assumed that r is constant, it need not be known or directly measurable. However, in many mechatronic applications, including printing systems [16], wafer scanners [6], semiconductor backend equipment [11], and additive manufacturing [24], setpoints change each iteration. Small variations can already lead to a disastrous effect. To see this, let r_j depend on the task. Following the approach in Sec. IV-A, this leads to $e_1 = S r_1 - G S L e_0$, where $e_0 = S r_0$, hence if $L = (GS)^{-1}$ then $e_1 = S(r_1 - r_0)$.

To cope with setpoint variations, several frameworks have been developed. These include approaches where the setpoint is built up from a library of subtasks [26], initialization based on model knowledge [28], use of Artificial Neural Networks (ANNs) [34], and basis function ILC. Regarding the latter, this includes the use of polynomial basis functions, which resembles traditional feedforward where the parameters such as m as described in Sec. II-D are automatically learned [55] [33], see also [18] for an early result in this direction. Further developments regarding input shaping are presented in [12] and rational systems in [14], [6]. These approaches typically employ the so-called lifted formulation, involving finite time signals and optimization criteria as in [23]. In [11], basis functions are incorporated in the design approach of Sec. IV.

Finally, an important aspect in basis function ILC is the actual selection of basis functions. This is essentially a model order selection problem, which connects to recent results in machine learning. It is addressed in [40] from a sparse optimization viewpoint. A fundamentally different approach is taken in [8] by using kernel-based regression, essentially viewing the system as a Gaussian Process (GP), see also [43].

Basis function ILC is applied to the multiple-input multiple-output industrial printer in Fig. 13, see Fig. 14 for the results. It can be directly observed that a change of reference at task

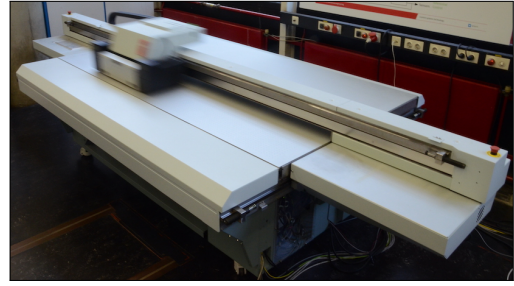

Fig. 13. Multiple-input multiple-output industrial printer with varying setpoints.

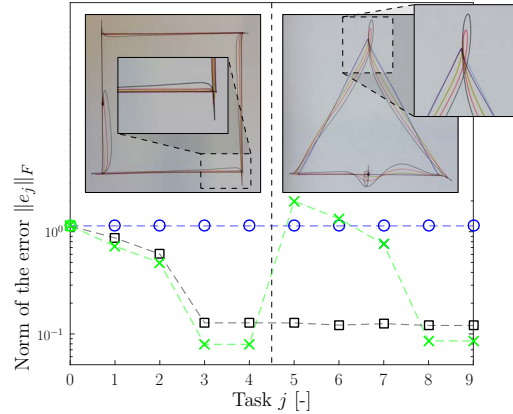

Fig. 14. Learning with varying references on the flatbed printer in Fig. 13. In task $j = 0, 1, 2, 3, 4$, the setpoint is a square. Learning control (green crosses) substantially increases performance compared to feedback (blue circles). However, after a setpoint change to a triangle from task $j = 5$ onwards, the ILC performance deteriorates and becomes worse compared to feedback only. ILC using basis functions (black squares) combines task flexibility and high performance.

$j = 5$ deteriorates the performance of the ILC approach of Sec. IV, in fact the performance is worse compared to only using feedback. In sharp contrast, ILC with basis functions combines high performance and task flexibility.

B. Multivariable learning

Industrial motion systems, including the printer in Fig. 13, often have multiple actuators and sensors. Application of the scalar ILC approach of Sec. IV to several input-output pairs sequentially or simultaneously may lead to disastrous results. Indeed, as is shown in Sec. IV-B, ILC essentially is a feedback mechanism in the iteration domain. It is well-known that interaction is a key aspect in multivariable feedback control. In fact, since ILC is effective over a much larger bandwidth compared to traditional feedback control, see Sec. II-C, interaction is substantially more important.

In [9], [10], a multivariable ILC design framework is presented that extends the design philosophy of the approach in Sec. IV. In particular, it uses nonparametric frequency response functions of the interaction elements to design L and Q .

Application of the approach of Sec. IV to the printer in Fig. 13 leads to a diverging error, where $\|\cdot\|_F$ denotes the Frobenius norm. In contrast, the approach in [9] leads to a converging error by accounting for interaction, see Fig. 15.

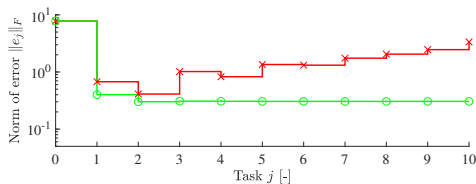

Fig. 15. Learning for multiple axes on the flatbed printer in Fig. 13. Ignoring interaction by straightforward application of the approach in Sec. IV leads to a divergent behavior (red crosses). Application of multivariable ILC leads to a converging error (green circles).

C. Inferential ILC

Mechatronic systems often cannot be assumed rigid anymore due to extreme performance and accuracy requirements that are enabled by learning control. For instance, in the printer systems of Fig. 3 and Fig. 13, the position is measured using an encoder, while performance is required at the printing location. This is referred to as an inferential control situation [39]. Also, sampled-data ILC is closely related, where only discrete observations of the performance variables are available [41].

ILC operates from one task to the next, also referred to as a batch-to-batch control approach, hence it can exploit measurements of the product. For instance, in printing systems, a scanner that immediately scans the print after each line [16] can be used in conjunction with ILC. Although this is a very promising concept, a recent analysis [15] has shown that traditional ILC approaches, including the approach in Sec. IV, lead to an internally unstable closed-loop situation if they are combined with feedback on the encoder. By adopting appropriate ILC structures, ILC can be directly applied to improve the performance of such inferential control problems.

D. Position-dependent and position-domain ILC

Traditional ILC mainly involves linear and time-invariant systems, yet for many mechatronic systems this assumption is not satisfied. First, input-output dynamics may be nonlinear, including changing mass distributions in H-drive systems, such as the printer of Fig. 13 and positioning system in [22], as well as varying sensor locations such as in wafer scanners [54]. To address these nonlinear dynamics, both LPV ILC [48] and LTV ILC [56] are explored. Second, disturbances may be position-dependent, including errors induced by position-dependent commutation in motors and piezo-stepper actuators for long-range motion, which is investigated in ILC in [1]. In [35], a closely related Gaussian process-based approach is developed. Third, measurements may be position-dependent as in encoder systems, which has been addressed through an intermittent sampling ILC approach [52]. Fourth, performance requirements may be position-dependent, e.g., in 3D printing, which has led to cross-coupled ILC [4] and spatial ILC [27].

E. Integrated data-driven modeling and learning

The ILC design approach in Sec. IV requires a parametric model, see in particular Sec. IV-B3. This allows for a robust design for a range of identified frequency response functions. However, it requires a parametric modeling step, which is

relatively time consuming, and a robustness filter Q , which may lead to a residual asymptotic error and conservatism.

To avoid the parametric modeling step, several approaches have been developed. In [29], the learning filter L is directly based on a nonparametric frequency response function, which is extended towards online estimation of the frequency response function in [47]. A gradient-descent ILC approach is developed in [13], which estimates the gradient using dedicated experiments on the real system. In [44], an actor-critic approach is developed for basis function ILC, see Sec. V-A, that avoids the use of explicit models by employing results from reinforcement learning, see, e.g., [45] for related recent developments.

VI. CONCLUSIONS

Iterative learning control enables a major performance improvement for mechatronic systems. By employing inversion-based learning, fast convergence can be achieved within just a few iterations. Robustness can be enforced by employing frequency response function measurements for a large range of operating conditions or machine-to-machine variability. In recent years, ILC has been extended to facilitate widespread industrial deployment for mechatronic systems. These results are foreseen to enable a major performance improvement.

Acknowledgements The framework presented here is the result of a fruitful collaboration with many colleagues in academia and industry who are gratefully acknowledged. In particular, Leontine Aarnoudse, Frank Boeren, Lennart Blanken, Joost Bolder, Noud Mooren, Maurice Poot, Robin de Rozario, Nard Strijbosch, and Jurgen van Zundert have had a major role in the ideas outlined here. Financial support is provided by VIDI project number 15698, which is (partly) financed by the Netherlands Organisation for Scientific Research (NWO) and ECSEL-2016-1 under grant agreement number 737453 (I-MECH).

REFERENCES

- [1] L. Aarnoudse, N. Strijbosch, E. Verschueren, and T. Oomen, "Commutation-angle iterative learning control for intermittent data: Enhancing piezo-stepper actuator waveforms," in *IFAC 21st Triennial World Congress*, Berlin, Germany, 2020.
- [2] D. Abramovitch, S. Andersson, L. Pao, and G. Schitter, "A tutorial on the mechanics, dynamics, and control of atomic force microscopes," in *Proc. ACC*, New York, NY, 2007, pp. 3488–3502.
- [3] S. Arimoto, S. Kawamura, and F. Miyazaki, "Bettering operation of robots by learning," *J. Rob. Syst.*, vol. 1, no. 2, pp. 123–140, 1984.
- [4] K. L. Barton and A. G. Alleyne, "A cross-coupled iterative learning control design for precision mechatronics," *IEEE Trans. Contr. Syst. Techn.*, vol. 16, no. 6, pp. 1218–1231, 2008.
- [5] Z. Bien and J.-X. Xu, *Iterative Learning Control: Analysis, Design, Integration and Applications*. Norwell, MA: Kluwer Academic Publishers, 1998.
- [6] L. Blanken, F. Boeren, D. Bruijnen, and T. Oomen, "Batch-to-batch rational feedforward control: from iterative learning to identification approaches, with application to a wafer stage," *IEEE/ASME Trans. Mech.*, vol. 22, no. 2, pp. 826–837, 2017.
- [7] L. Blanken, S. Koekebakker, and T. Oomen, "Multivariable repetitive control: Decentralized designs with application to continuous media flow printing," *IEEE/ASME Trans. Mech.*, vol. 25, no. 1, pp. 294–304, 2020.
- [8] L. Blanken and T. Oomen, "Kernel-based identification of non-causal systems with application to inverse model control," *Automatica*, vol. 114, p. 108830, 2020.
- [9] —, "Multivariable iterative learning control design procedures: From decentralized to centralized, illustrated on an industrial printer," *IEEE Trans. Contr. Syst. Techn.*, To appear.
- [10] L. Blanken, J. van Zundert, R. de Rozario, N. Strijbosch, and T. Oomen, "Multivariable iterative learning control: Analysis and designs for engineering applications," in *Data-Driven Modeling, Filtering and Control*, C. Novara and S. Formentin, Eds. IET The Institution of Engineering and Technology, 2019, pp. 109–138.

- [11] F. Boeren, A. Bareja, T. Kok, and T. Oomen, "Frequency-domain ILC approach for repeating and varying tasks: With application to semiconductor bonding equipment," *IEEE/ASME Trans. Mech.*, vol. 21, no. 6, pp. 2716–2727, 2016.
- [12] F. Boeren, D. Bruijnen, N. van Dijk, and T. Oomen, "Joint input shaping and feedforward for point-to-point motion: Automated tuning for an industrial nanopositioning system," *Mechatronics*, vol. 24, no. 6, pp. 572–581, 2014.
- [13] J. Bolder, S. Kleinendorst, and T. Oomen, "Data-driven multivariable ILC: Enhanced performance by eliminating L and Q filters," *Int. J. Rob. Nonlin. Contr.*, vol. 28, no. 12, pp. 3728–3751, 2018.
- [14] J. Bolder and T. Oomen, "Rational basis functions in iterative learning control - with experimental verification on a motion system," *IEEE Trans. Contr. Syst. Techn.*, vol. 23, no. 2, pp. 722–729, 2015.
- [15] —, "Inferential iterative learning control: A 2D-system approach," *Automatica*, vol. 71, pp. 247–253, 2016.
- [16] J. Bolder, T. Oomen, S. Koekebakker, and M. Steinbuch, "Using iterative learning control with basis functions to compensate medium deformation in a wide-format inkjet printer," *Mechatronics*, vol. 24, no. 8, pp. 944–953, 2014.
- [17] D. A. Bristow, M. Tharayil, and A. G. Alleyne, "A survey of iterative learning control: A learning-based method for high-performance tracking control," *IEEE Contr. Syst. Mag.*, vol. 26, no. 3, pp. 96–114, 2006.
- [18] J. A. Frueh and M. Q. Phan, "Linear quadratic optimal learning control (LQL)," *Int. J. Contr.*, vol. 73, no. 10, pp. 832–839, 2000.
- [19] W. K. Gawronski, *Advanced Structural Dynamics and Active Control of Structures*. New York, NY: Springer, 2004.
- [20] M. Ghazaei, S. Z. Khong, and B. Bernhardsson, "On the convergence of iterative learning control," *Automatica*, vol. 78, pp. 266–273, 2017.
- [21] D. Gorinevsky, "Loop shaping for iterative control of batch processes," *IEEE Contr. Syst. Mag.*, vol. 22, no. 6, pp. 55–65, 2002.
- [22] M. Groot Wassink, M. van de Wal, C. Scherer, and O. Bosgra, "LPV control for a wafer stage: Beyond the theoretical solution," *Contr. Eng. Prac.*, vol. 13, pp. 231–245, 2003.
- [23] S. Gunnarsson and M. Norrlöf, "On the design of ILC algorithms using optimization," *Automatica*, vol. 37, pp. 2011–2016, 2001.
- [24] Y. Guo, J. Peters, T. Oomen, and S. Mishra, "Control-oriented models for ink-jet 3D printing," *Mechatronics*, vol. 56, pp. 211–219, 2018.
- [25] M. Heertjes, "Data-based motion control of wafer scanners," in *IFAC-PapersOnLine 49-13*, 2016, pp. 001–012.
- [26] D. J. Hoelzle, A. G. Alleyne, and A. J. Wagoner Johnson, "Basis task approach to iterative learning control with applications to micro-robotic deposition," *IEEE Trans. Contr. Syst. Techn.*, vol. 19, no. 5, pp. 1138–1148, 2011.
- [27] D. J. Hoelzle and K. L. Barton, "On spatial iterative learning control via 2-D convolution: Stability analysis and computational efficiency," *IEEE Trans. Contr. Syst. Techn.*, vol. 24, no. 4, pp. 1504–1512, 2016.
- [28] P. Janssens, G. Pipeleers, and J. Swevers, "Initialization of ILC based on a previously learned trajectory," in *Proc. ACC*, Montreal, Canada, 2012, pp. 610–614.
- [29] K.-S. Kim and Q. Zou, "A modeling-free inversion-based iterative feedforward control for precision output tracking of linear time-invariant systems," *IEEE/ASME Trans. Mech.*, vol. 18, no. 6, pp. 1767–1777, 2013.
- [30] P. Lambrechts, M. Boerlage, and M. Steinbuch, "Trajectory planning and feedforward design for electromechanical motion systems," *Contr. Eng. Prac.*, vol. 13, pp. 145–157, 2005.
- [31] R. W. Longman, "Iterative learning control and repetitive control for engineering practice," *Int. J. Contr.*, vol. 73, no. 10, pp. 930–954, 2000.
- [32] R. van der Maas, A. van der Maas, R. Voorhoeve, and T. Oomen, "Accurate FRF identification of LPV systems: nD-LPM with application to a medical X-ray system," *IEEE Trans. Contr. Syst. Techn.*, vol. 25, no. 4, pp. 1724–1735, 2017.
- [33] S. van der Meulen, R. L. Tousain, and O. H. Bosgra, "Fixed structure feedforward controller design exploiting iterative trials: Application to a wafer stage and a desktop printer," *J. Dyn. Syst., Meas., and Contr.*, vol. 130, pp. 051006–1, 2008.
- [34] K. L. Moore, *Iterative Learning Control for Deterministic Systems*. London, UK: Springer-Verlag, 1993.
- [35] N. Mooren, G. Witvoet, and T. Oomen, "Gaussian process repetitive control for suppressing spatial disturbances," in *IFAC 2017 Triennial World Congress*, Berlin, Germany, 2020.
- [36] R. Munnig Schmidt, G. Schitter, and J. van Eijk, *The Design of High Performance Mechatronics*. Delft, The Netherlands: Delft University Press, 2011.
- [37] T. Oomen, "Learning in machines," *Mikroniek*, vol. 6, pp. 5–11, 2018.
- [38] —, "Control for precision mechatronics," in *Encyclopedia of Systems and Control*, 2nd ed., J. Baillieul and T. Samad, Eds. Springer Nature, 2020.
- [39] T. Oomen, E. Grassens, and F. Hendriks, "Inferential motion control: An identification and robust control framework for unmeasured performance variables," *IEEE Trans. Contr. Syst. Techn.*, vol. 23, no. 4, pp. 1602–1610, 2015.
- [40] T. Oomen and C. R. Rojas, "Sparse iterative learning control with application to a wafer stage: Achieving performance, resource efficiency, and task flexibility," *Mechatronics*, vol. 47, pp. 134–137, 2017.
- [41] T. Oomen, J. van de Wijdeven, and O. Bosgra, "Suppressing intersample behavior in iterative learning control," *Automatica*, vol. 45, no. 4, pp. 981–988, 2009.
- [42] W. Paszke, E. Rogers, and K. Galkowski, "Experimentally verified generalized KYP lemma based iterative learning control design," *Contr. Eng. Prac.*, vol. 53, pp. 57–67, 2016.
- [43] G. Pilonetto, F. Dinuzzo, T. Chen, G. De Nicolao, and L. Ljung, "Kernel methods in system identification, machine learning and function estimation: A survey," *Automatica*, vol. 50, no. 3, pp. 657–682, 2014.
- [44] M. Poot, J. Portegies, and T. Oomen, "On the role of models in learning control: Actor-critic iterative learning control," in *IFAC 21st Triennial World Congress*, Berlin, Germany, 2020.
- [45] B. Recht, "A tour of reinforcement learning: The view from continuous control," *Annual Review of Control, Robotics, and Autonomous Systems*, vol. 2, pp. 253–279, 2019.
- [46] E. Rogers, K. Galkowski, and D. H. Owens, *Control Systems Theory and Applications for Linear Repetitive Processes*, ser. LNCIS. Berlin, Germany: Springer, 2007, no. 349.
- [47] R. de Rozario and T. Oomen, "Data-driven iterative inversion-based control: Achieving robustness through nonlinear learning," *Automatica*, vol. 107, pp. 342–352, 2019.
- [48] R. de Rozario, T. Oomen, and M. Steinbuch, "ILC and feedforward control for LPV systems: with application to a position-dependent motion system," in *Proc. ACC*, Seattle, WA, 2017, pp. 3518–3523.
- [49] D. Silver, J. Schrittwieser, K. Simonyan, I. Antonoglou, A. Huang, A. Guez, T. Hubert, L. Baker, M. Lai, A. Bolton, Y. Chen, T. Lillicrap, F. Hui, L. Sifre, G. van den Driessche, T. Graepel, and D. Hassabis, "Mastering the game of Go without human knowledge," *Nature*, vol. 550, pp. 354–359, 2017.
- [50] G. Stein, "Respect the unstable," *IEEE Contr. Syst. Mag.*, vol. 23, no. 4, pp. 12–25, 2003.
- [51] M. Steinbuch and R. v. d. Molengraft, "Iterative learning control of industrial motion systems," in *1st IFAC Symp. Mech. Syst.*, Darmstadt, Germany, 2000, pp. 967–972.
- [52] N. Strijbosch and T. Oomen, "Intermittent sampling in iterative learning control: a monotonically-convergent gradient-descent approach with application to time stamping," in *Proc. CDC*, Nice, France, 2019, pp. 6542–6547.
- [53] M. Togai and O. Yamano, "Analysis and design of an optimal learning control scheme for industrial robots: A discrete system approach," in *Proc. CDC*, Fort Lauderdale, FL, 1985, pp. 1399–1404.
- [54] R. Voorhoeve, R. de Rozario, W. Aangenent, and T. Oomen, "Identifying position-dependent mechanical systems: A modal approach with applications to wafer stage control," *IEEE Trans. Contr. Syst. Techn.*, To appear.
- [55] J. van de Wijdeven and O. Bosgra, "Using basis functions in iterative learning control: Analysis and design theory," *Int. J. Contr.*, vol. 83, no. 4, pp. 661–675, 2010.
- [56] J. van Zundert, J. Bolder, S. Koekebakker, and T. Oomen, "Resource-efficient ILC for LTI/LTV systems through LQ tracking and stable inversion: Enabling large tasks on a position-dependent industrial printer," *Mechatronics*, vol. 38, pp. 76–90, 2016.
- [57] J. van Zundert and T. Oomen, "On optimal feedforward and ILC: The role of feedback for optimal performance and inferential control," in *IFAC 2017 Triennial World Congress*, Toulouse, France, 2017, pp. 6267–6272.
- [58] —, "On inversion-based approaches for feedforward and ILC," *Mechatronics*, vol. 50, pp. 282–291, 2018.