

Design of an Efficient Single-Stage and 2-Stages Class-E Power Amplifier (2.4GHz) for Internet-of-Things

Ayyaz Ali*, Syed Waqas Haider Shah[†], Khalid Iqbal[‡]

*Department of Electrical Engineering, Army Public College of Management & Sciences, Rawalpindi (46000), Pakistan

[†]Department of Electrical Engineering, Information Technology University, Lahore (54000), Pakistan

[‡]National University of Science and Technology, Islamabad (46000), Pakistan

ayyazali21@yahoo.com, waqas.haider@itu.edu.pk, kiqbal@ceme.must.edu.pk

Abstract—In this work, the designs of a single-stage and 2-stage 2.4 GHz power amplifier (PA) are presented. The proposed PAs have been designed to provide high gain and improved efficiency using harmonic suppression and optimized impedance matching techniques. There are two harmonic suppression circuits, each stage of the PA consists of 2 capacitors and 2 inductors, which will help to suppress the harmonic frequency for 2.4 GHz. These suppression circuits will help to enhance the overall efficiency of the PAs. Both the PAs are provided with a VCC supply of 4.2V. Input and output impedances are matched to 50 ohms. Simulation and experimental results are presented, where the simulated gain and power added efficiency (PAE) for single stage PA are 17.58dB and 53%, respectively. While the experimental gain and PAE are 16.7dB and 49.5%, respectively. On the other hand, for 2-stages PA, simulated gain comes out to be 34.6dB and PAE is 55%, while the experimental gain and PAE are 30.5dB and 53.1%, respectively. The final design is being fabricated on the Taconic printed circuit board (PCB) with a thickness of 0.79mm and dielectric constant value of 3.2 and its dimensions are 4.6cm × 3.4cm for single stage and 5.9cm × 3.6cm for 2-stages PA.

Index Terms—2.4 GHz power amplifier, class-E power amplifier, power added efficiency (PAE), Internet-of-Things

I. INTRODUCTION

There has been a lot of development in wireless communication in recent years. Especially with the advent of Internet-of-Things (IoT), need for low cost and low power wireless communication systems are increasing rapidly with small size and enhanced efficiency. One of the most important parts of any wireless communication network is a power amplifier (PA) present at the transmit station [1]. Most of the IoT applications requires battery operated devices such as home and factory automation, smart cities and connected agriculture. These devices are designed such that they consume lesser and lesser power for their operation. Major consumption of power of a device is associated with its transmitter section, in which further mostly power is consumed by the PA of that transmitter. Such PAs need to be efficient enough so that they may use little battery power and provide enough gain which will enhance the power of an input signal. In any PA, two main characteristics which need the most consideration are the efficiency and linearity [2]. When designing a PA, the selection of the right circuit, class topology and semiconductor

TABLE I: Comparison of Linearity and Efficiency between different Classes of PA

Class	Ideal Efficiency	Linearity	Practical Efficiency
Class-A	50 %	Good	35%
Class-AB	50% - 78.5%	Good	45%
Class-B	78.5%	Moderate	49%
Class-C	78.5% - 100%	Poor	55%
Class-E	100%	Poor	62%
Class-F	100%	Poor	80%

greatly affects the linearity and efficiency. PAs can basically be classified as linear and nonlinear. The efficiency of nonlinear PA is much greater when compared to linear PA [3]. Out of different efficient classes (Class D, E, and F) of PA, Class-E is a suitable choice for the design of an efficient PA with switch mode input circuitry. A comparison of linearity and

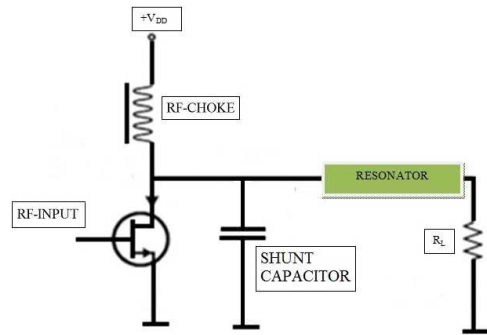

Fig. 1: Basic design of Class-E PA.

efficiency between different classes of PAs are shown in Table 1 from where it can be seen that a Class-E topology for the design of an efficient PA would be a good choice. From [8] the selection of the topology is highly dependent upon the radio frequency (RF) choke size. If this size is to be finite in nature then the design calculation formula for Class-E PA will not be well-suited. Keeping the frequency and output power fixed, the Class-E PA have a power loss of 2.3 less as compared to Class-B or Class C amplifiers [9].

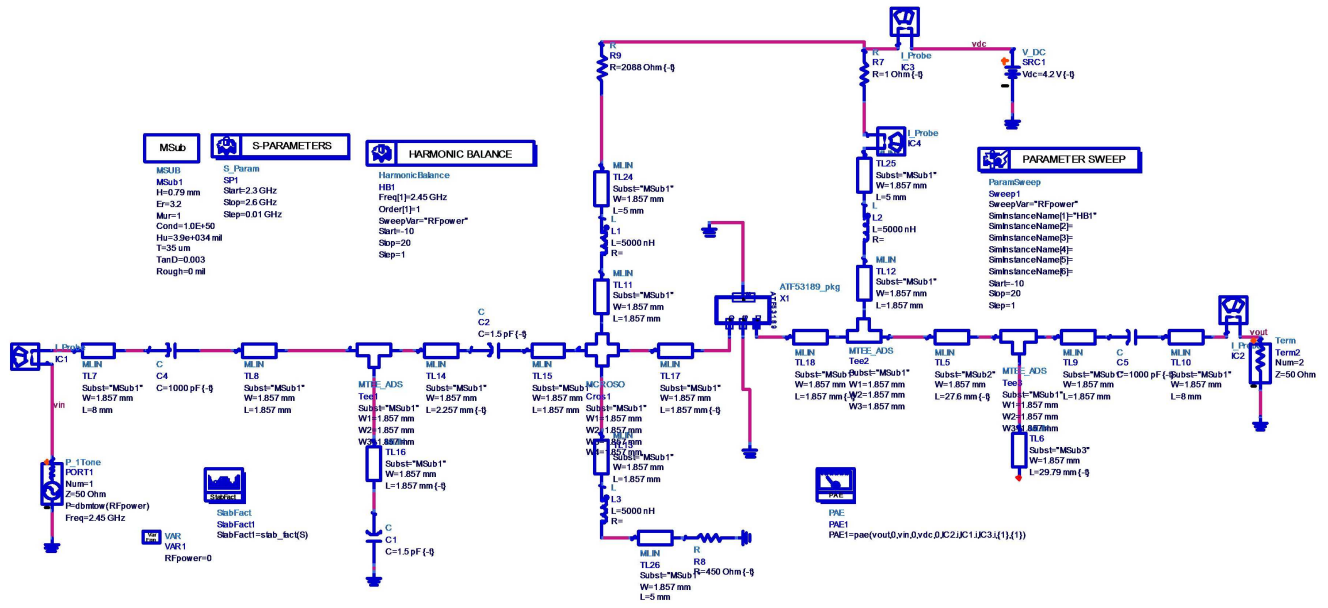

Fig. 3: Schematic diagram of single-stage PA with input and output matching circuits.

transistor stable but it will reduce the overall output gain of the P.A, that's why a transistor with stable characteristic at the desired frequency is preferred. After selection of the transistor, it is best practice to test its linear model on the software which should produce the same results of current and voltage as mentioned in its datasheet. In the proposed PA we have used ATF-53189 transistor because of its high efficiency.

B. Simulation Design of Proposed Single Stage P.A.

The simulation for the design of proposed single stage Class-E PA is performed on advanced design system (ADS). As it is required to find the value of maximum PAE so a harmonic balance should be introduced in this simulation and for that the non linear model of transistor ATF-53189 is used. The main parameters which are needed in order to find the value of PAE are input RF power, output RF power, input DC voltage and input DC current. Parameter sweep range is selected from -10dB up to 20dB.

Fig.3 shows the schematic diagram of PA with input and output matching circuits. The perfectly matched input and output impedance is achieved by tuning the capacitors and transmission lines for maximum output gain. Both the input and output matching circuits are matched with 50 Ohm impedance port. Test results for the schematic shown in Fig. 3 are revealed in Fig. 4(a) and 4(b). In Fig. 4(a) the output gain is found to be 18dBm. In Fig. 4(b) the value of total PAE is 45.5% and it can be seen that the PAE is improved and its maximum value is obtained at an input RF power of 14dBm. After the addition of harmonic suppression circuits and optimizing the impedance matching circuits the maximum PAE that could be achieved is 53% at an input RF power of

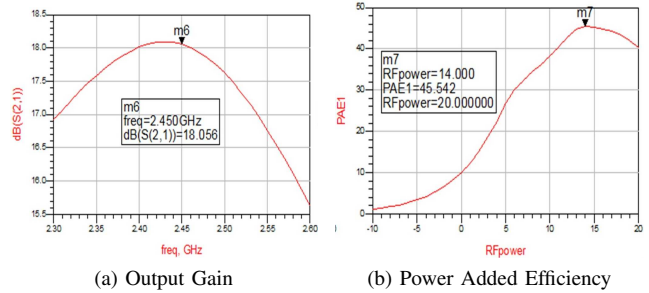

Fig. 4: Proposed single-stage PA with input and output matching circuits.

16dBm while appending the H.S circuits the new gain of P.A is now 17.5dBm. Fig. 6(a) and 6(b) shows the final S-Parameter results together with PAE.

To further improve the PAE of this Class-E PA two harmonic suppression circuits are added at the input side of amplifier. These circuits help to reduce the power consumed at the harmonic frequencies which will enhance the overall efficiency of this amplifier. The co-simulation of the added harmonic suppression circuits and optimized input output impedance matching circuits is shown in Fig. 5.

C. Fabrication of the Proposed Design

The proposed single stage PA is fabricated on taconic PCB with thickness of 0.79mm and Dielectric constant 3.2. The size of the PCB is 4.6cm x 3.4cm. The PA is matched to 50 ohm source and load ports. Proper grounding of top and bottom layer is performed by drilling holes and then using a wire to

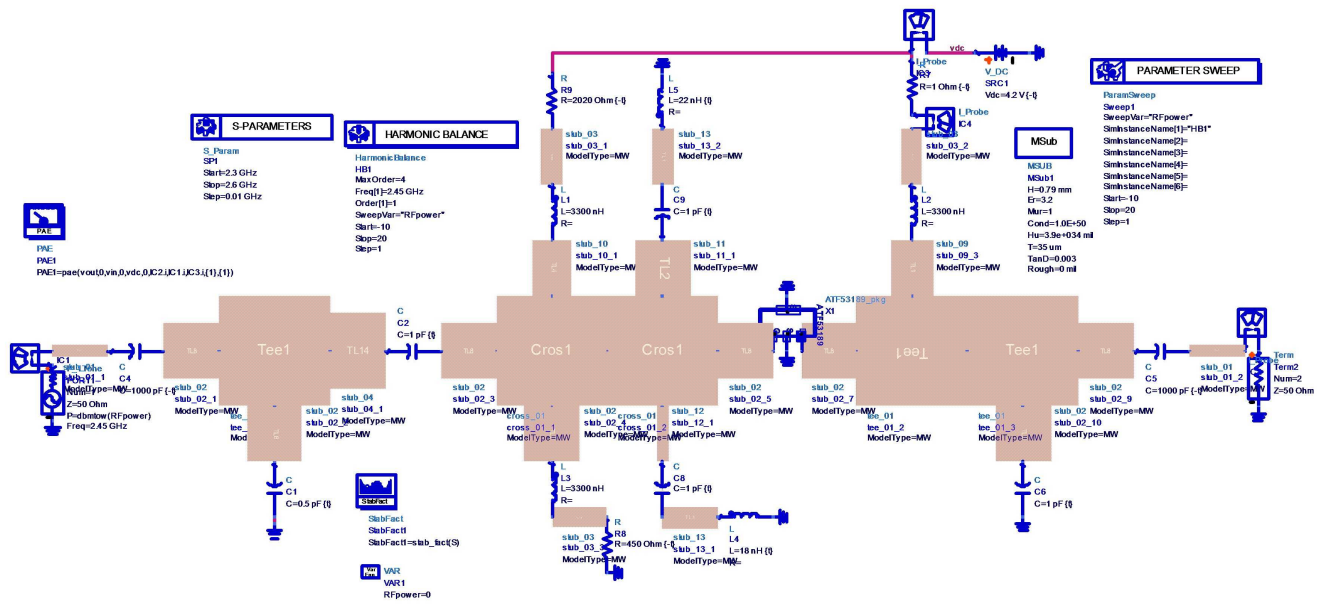

Fig. 5: Co-simulation of proposed single-stage PA with Harmonic Suppression circuits.

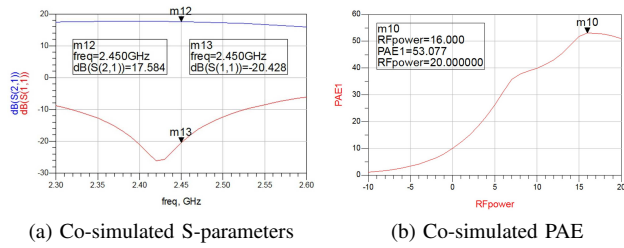

Fig. 6: Proposed single-stage class-E PA with Harmonic Suppression circuits.

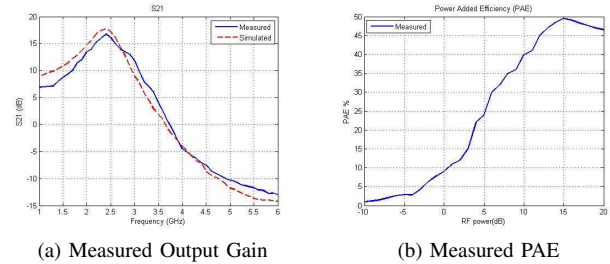

Fig. 8: Proposed single-stage class-E PA.

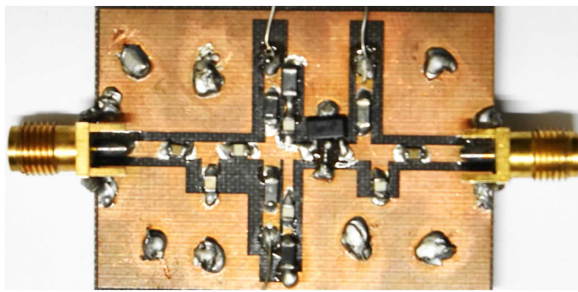

Fig. 7: Fabricated design of proposed single-stage class-E PA.

connect the top and bottom layer at different locations on the PCB. Fig. 7 shows the fabricated design of the proposed single stage PA.

D. Measured Results

Fig. 8 shows the measured results of the proposed single stage PA where for different values of frequencies, the output

gain of the PA is shown in Fig. 8(a). From this figure the measured output gain comes out to be 16.7dB which is very close to the simulated results. The plot for PAE can also be seen in Fig. 8(b). From this graph it can be seen that the maximum efficiency of 49.5% is achieved at an input RF power of 15dB which is also similar to the simulated results.

III. DESIGN OF PROPOSED 2-STAGE P.A.

In the proposed 2-stages PA, two single stage PAs are connected in cascade fashion as shown in Fig. 9. The design of 2-stage PA is the same as was for the single stage, the only difference is the impedance matching circuit which is added between the two amplifiers while cascading. Resistors R7, R8 and R9 are the biasing resistors for the 1st stage while resistors R10, R11 and R12 are for 2nd stage of the 2-stages PA. Capacitor C2 and transmission line TL2 are the input impedance matching circuits while capacitor C14 and C11 are the output matching circuits. The impedance matching between the 1st stage and 2nd stage of the Amplifier is achieved with the help

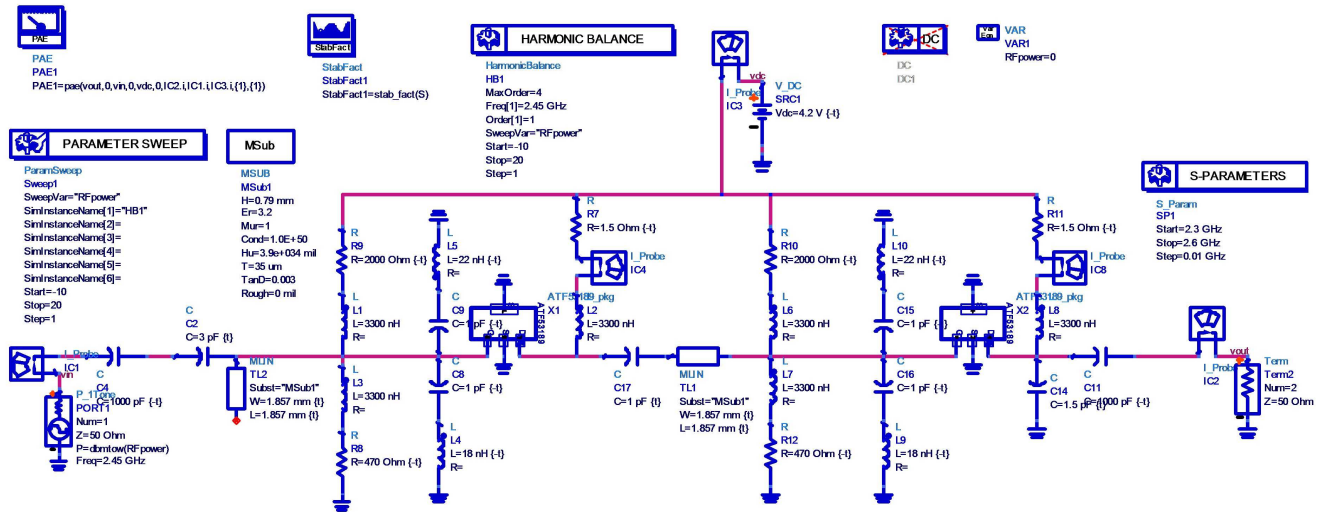
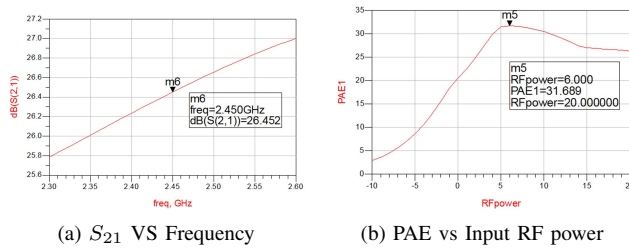
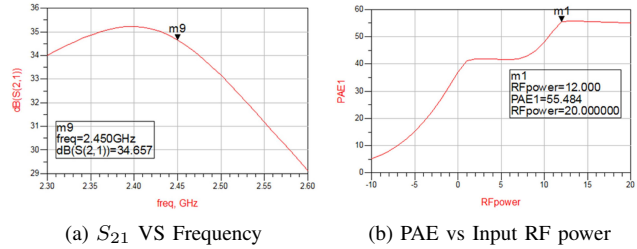

Fig. 9: Schematic diagram of the proposed 2-stage class-E PA.



(a) S_{21} VS Frequency (b) PAE vs Input RF power

Fig. 10: Simulated two-stages class-E PA.



(a) S_{21} VS Frequency (b) PAE vs Input RF power

Fig. 11: Co-simulated two-stages class-E PA.

of capacitor C17 and transmission line TL1. The capacitor C17 also helps to prevent any interference of 1st stage biasing circuit with the 2nd stage biasing circuit. Capacitors C4 and C11 are the coupling capacitors while inductors L1-L3 and L6-L8 are DC pass inductors to stop the AC signal from going towards DC power supply. Unwanted harmonics are filtered by inductors L4, L5, L9, L10 and capacitors C8, C9, C15 and C16. The Supply voltage VCC is kept 4.2 volts as was for single stage PA but its current consumption would be twice than single stage as there are two PA cascaded. This PA design was targeted towards better output gain while compensating for little loss in efficiency. From Fig. 10(a) and 10(b), the output gain parameter S_{21} comes out to be 26.45dB while the PAE is 31.6%. For optimizing and tuning the two-stages PA, first the schematic diagram is moved for co-simulation and then it is simulated to get the optimized results, next step is the tuning where different components are selected for tuning and while changing the values of lumped components results are improved. In our design the input-output matching circuits and DC blocking capacitors are tuned to get maximum gain from this 2-stages PA. In Fig. 11(a) and 11(b) plots for gain and PAE are shown. It is clear that the optimizing and tuning

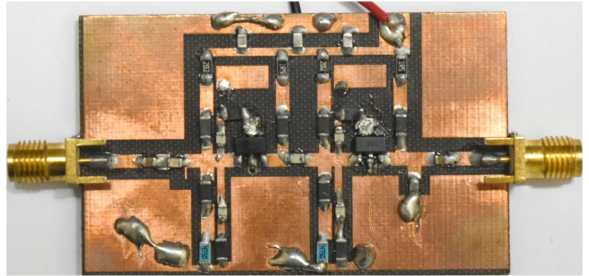

Fig. 12: Fabricated design of the Proposed 2-stages class-E PA.

of schematic in co-simulation has increased the gain of PA and now it has improved up to 34.6dB which is more than twice as was for single stage PA. The PAE came out to be 55.4%.

A. Fabrication of the Proposed Design

The 2-stages PA is fabricated on taconic PCB with dielectric constant value of 3.2 and thickness of 0.79mm as shown in Fig. 12. The dimensions of the capacitors and inductors used here are according to the standard of 0805 and 1206 respectively.

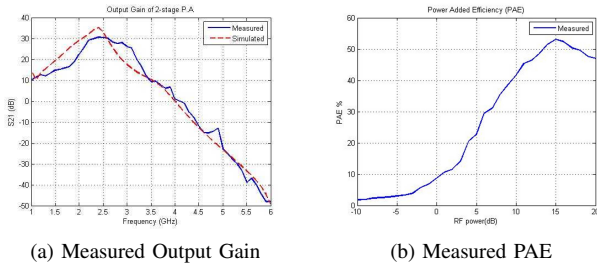

Fig. 13: Measured results of the proposed two-stages class-E PA.

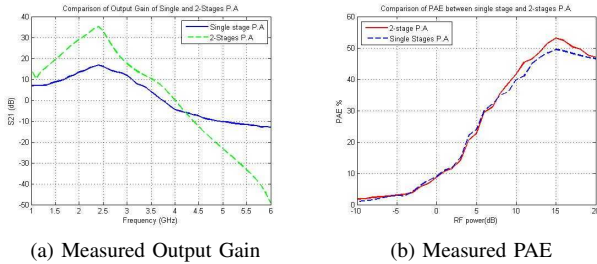

Fig. 14: Comparison between single-stage and 2-stage class-E PAs.

The grounding of transistor is directly done using thin wires with the lower side of the PCB as it affects the gain of the PA. The dimensions of the PCB are 5.9cm x 3.6cm.

B. Measured Results

The measured output gain of 2-stage PA is shown in Fig.13(a). The maximum gain achieved at 2.4GHz is 30.5dB which is very close to the simulated results. For 2-stage PA the maximum PAE is measured and found to be 53.1% which is shown in Fig.13(b).

IV. RESULT COMPARISON OF SINGLE STAGE AND 2-STAGE P.A.

A comparison of measured total output gain and PAE is carried out between the single stage and 2-stages PA and is shown in Fig.14(a) and 14(b). As can be seen from Fig.14(a) the output Gain of 2-stages PA is twofold as compared to the gain of single stage PA but the graph is more linear in case of single stage. In Fig.14(b) there is a linear rise of PAE for both single stage and 2-stages PA but the later one is showing a greater peak as compared to the single stage.

One can conclude further from the above presented results that the proposed 2-stage PA is far more better than the single stage for total output gain as well as PAE, but if the requirement is just the linearity than the proposed single stage PA would be a better choice. Since the output gain of 2-stage PA is twice than the single stage so for a longer distance communication this amplifier would be an appropriate choice, also it will give better efficiency but it will cost more input DC power whereas if there is a requirement of security and

privacy then the proposed single stage PA should be selected as it will transmit signals to a shorter distance and there will be less chances for any intruder to hack the signal.

V. CONCLUSION

In this work, the design of an efficient single stage and 2-stage PAs have been presented with high output gain. In order to improve the efficiency and output gain of these PAs, harmonic suppression and the optimized impedance matching circuits are used.

The proposed PAs shows good simulation and experimental results, where the measured efficiency of single stage and 2-stage PAs comes out to be 49.5% and 51.3%, respectively. Similarly the experimental output gain for single stage and 2-stages PAs are 16.7dB and 30.5dB, respectively. These results show that the proposed PAs are very useful in various IoT applications which are energy and resource-constrained. Applications like smart farming and connected agriculture require such devices which are power-efficient and our designed single stage class-E PA can be a good candidate for it. On the other hand, for applications with high-efficiency requirements such as factory and process automation, our designed 2-stage class-E PA can play an important role.

REFERENCES

- [1] Shah, S. W. H., Amin, S., & Iqbal, K. (2016). An adaptive algorithm for mu-mimo using spatial channel model. *International Journal of Engineering (IJE)*, 10(1), 1.
- [2] van der Heijden, M. P., Acar, M., & Vromans, J. S. (2009, June). A compact 12-watt high-efficiency 2.1-2.7 GHz class-E GaN HEMT power amplifier for base stations. In *Microwave Symposium Digest, 2009. MTT'09. IEEE MTT-S International* (pp. 657-660). IEEE.
- [3] Jie, S., Shulin, Z., Lei, C., Liang, T., Jin, Z., Ying, R., ... & Zongsheng, L. (2010, September). A 2.4 GHz high efficient monolithic Class E power amplifier. In *Microelectronics and Electronics (PrimeAsia), 2010 Asia Pacific Conference on Postgraduate Research in* (pp. 271-274). IEEE.
- [4] Meshkin, R., Saberhari, A., & Niaboli-Guilani, M. (2010, December). A novel 2.4 GHz CMOS class-E power amplifier with efficient power control for wireless communications. In *Electronics, circuits, and systems (ICECS), 2010 17th IEEE international conference on* (pp. 599-602). IEEE.
- [5] Thian, M., Fusco, V., & Gardner, P. (2010, December). 2.4 GHz high-efficiency power-combining Class-E amplifier with transmission-line harmonic traps. In *Microwave Conference Proceedings (APMC), 2010 Asia-Pacific* (pp. 666-669). IEEE.
- [6] Banerjee, A., & Chatterjee, A. (2013, May). An adaptive class-E power amplifier with improvement in efficiency, reliability and process variation tolerance. In *Circuits and Systems (ISCAS), 2013 IEEE International Symposium on* (pp. 745-748). IEEE.
- [7] Wu, R., Li, Y., Lopez, J., & Lie, D. Y. (2011, August). Design trade-offs for single-ended vs. differential Class-E SiGe bipolar power amplifiers with through-wafer-vias at 2.4 GHz. In *Circuits and Systems (MWSCAS), 2011 IEEE 54th International Midwest Symposium on* (pp. 1-4). IEEE.
- [8] Ostrovskyy, P., Scheytt, J. C., Sadeghfam, A., & Heuermann, H. (2012, October). Performance estimation of fully digital polar modulation driving a 2 GHz switch-mode power amplifier. In *Microwave Integrated Circuits Conference (EuMIC), 2012 7th European* (pp. 659-662). IEEE.
- [9] Raab, F. (1977). Idealized operation of the class E tuned power amplifier. *IEEE transactions on Circuits and Systems*, 24(12), 725-735.
- [10] Ali, A., & Shah, S. W. H. (2017, April). Design of a 1 GHz power amplifier with high output gain for antenna measurement trainer system. In *Communication Technologies (ComTech), 2017 International Conference on* (pp. 22-26). IEEE.