

Note: Development of a simple low phase noise microwave synthesizers utilizing sampling PLL for Rb atomic clock

Wenbing Li,^{1, a)} Qiang Hao,^{2, b)} Yuanbo Du,¹ Shaoqing Huang,¹ Peter Yun,² and Zehuang Lu^{1, c)}

¹⁾MOE Key Laboratory of Fundamental Physical Quantities Measurement, Hubei Key Laboratory of Gravitation and Quantum Physics, School of Physics, Huazhong University of Science and Technology, 1037 Luoyu Road, Wuhan 430074, P. R. China

²⁾Key Laboratory of Time and Frequency Primary Standards, National Time Service Center, Chinese Academy of Sciences, Xi'an 710600 P. R. China

(Dated: 10 October 2018)

The absolute phase noise of the local oscillator, especially at the offset frequencies range of 100 Hz to 1 kHz, is one of the main limitations to improve the short-term frequency stability of Rb atomic clocks whatever the Rb atomic clock is operated in continuous or pulsed optically pumped (POP) mode. Here we report on the development of a 6.835 GHz microwave synthesizer with low phase noise to be used as a local oscillator for the Rb atomic clocks. A 100 MHz oven controlled crystal oscillator (OCXO) with ultra-low phase noise is used as the initial signal source. A dielectric resonant oscillator (DRO) of 6.8 GHz is then directly phase locked to the 100 MHz OCXO utilizing the sampling phase lock loop (PLL). With the help of technique of the sampling PLL, the architecture of the synthesizer would be very simple. The cost of the synthesizer would be much lower. The absolute phase noises of the 6.835 GHz output signal are measured to be -47 dBc/Hz, -77 dBc/Hz, -104 dBc/Hz and -121 dBc/Hz at 1 Hz, 10 Hz, 100 Hz and 1 kHz offset frequencies, respectively. Correspondingly, the short-term frequency stability limit due to the absolute phase noises through the intermodulation or the Dick effect is theoretically estimated to be better than $5.0 \times 10^{-14} \tau^{1/2}$.

Rb atomic clock is widely used in the fields of telecommunication, global navigation satellite system (GNSS) and industrial applications because of its superior characteristics of high frequency stability, low power consumption and small volume.¹⁻³ In recent years with widespread GNSS applications, the frequency stability of Rb atomic clocks has been greatly improved. For the continuous optically pumped Rb atomic clock, a laser pumped Rb atomic clock with a short-term frequency stability of $1.4 \times 10^{-13} \tau^{-1/2}$ has been realized by University of Neuchatel.⁴ A lamp pumped Rb atomic clock with short-term frequency stability of $2.4 \times 10^{-13} \tau^{-1/2}$ has been reported by Wuhan Institute of Physics and Mathematics (WIPM), Chinese Academy of Sciences recently.⁵ To our knowledge, these results are the best reported short-term frequency stability for laser and lamp pumped Rb clocks, respectively. Due to the superiority of time-detached optically pumping and detection, the light frequency shifts of pulsed optically pumped (POP) Rb atomic clock could be eliminated. Thus, POP Rb atomic clock has great potential to achieve good long-term frequency stability. A POP Rb atomic clock with short-term frequency stability of $1.7 \times 10^{-13} \tau^{-1/2}$ has been developed by the Istituto Nazionale di Ricerca Metrologica (INRIM). But limited by the temperature sensitivity of the physical package, the medium-long-term frequency stability is still not good.⁶

For Rb atomic clocks based on the principle of continuous optically pumping or POP, the absolute phase noise of local oscillator is one of the most important limitations for improving the short-term frequency stability. This has been analyzed and verified by several groups.⁷⁻⁹ For the continuous interrogation atomic clocks, the frequency modulation noise of the local

^{a)}Corresponding author E-mail: wenbing_li@hust.edu.cn

^{b)}Corresponding author E-mail: haoq@ntsc.ac.cn

^{c)}Corresponding author E-mail: zehuangu@hust.edu.cn

TABLE I: The phase noise sensitivity floor of the FSWP26 with option B61 (Xcorr=1, dBc/Hz)

| Carrier frequency | 1 Hz | 10 Hz | 100 Hz | 1 kHz | 10 kHz | 100 kHz | 1 MHz |
|-------------------|------|-------|--------|-------|--------|---------|-------|
| 100 MHz | -92 | -115 | -140 | -166 | -170 | -173 | -175 |
| 7 GHz | -55 | -78 | -103 | -133 | -152 | -153 | -157 |

oscillator at even harmonics offset frequencies would affect its short-term frequency stability via the intermodulation effect.⁷ For the POP clocks, its short-term frequency stability would be affected by the absolute phase noise of the local oscillator through the Dick effect.⁸ For both type Rb atomic clocks, their short-term frequency stabilities would be limited by the absolute phase noise of the local oscillator, especially at the offset frequency range of 100 Hz to 1 kHz. In order to improve the short-term frequency stability of atomic clocks, it is beneficial to develop a synthesizer with low phase noise at these offset frequencies.

There are several reports on developing microwave synthesizers for atomic clocks.¹⁰⁻¹³ These schemes are usually based on an ultra-low phase noise 100 MHz OCXO as a reference signal source. In these schemes, the 100 MHz OCXO is usually frequency multiplied to 6.8 GHz (for Rb atomic clocks) or 9.2 GHz (for Cs atomic clocks) with a non-linear transmission line (NLTL) to phase lock a dielectric resonant oscillator (DRO). In order to suppress the additional phase noise of the NLTL, it is necessary to optimize its operation parameters of input power, input impedance and output impedance.¹⁴ Thus, the architecture of the schemes are very complex, bulky, and expensive. To simplify the structure, B. François et al. designed a simple microwave synthesizer with a 1.6 GHz custom-designed frequency multiplication module. But the subsequent frequency multiplication is still needed. Therefore, the structure of the synthesizer is still quite complicated.¹⁵

In this Note, we report on the development of a 6.835 GHz microwave synthesizer with low phase noise. The architecture of the synthesizer is shown in Fig. 1. The 100 MHz OCXO (Beijing Institute of Radio Metrology and Measurement, ZF550) is divided into two arms via a power splitter (Mini-Circuits, ZX10-2-12+). The first arm 100 MHz signal is used as the reference for a home-made direct digital synthesizer (DDS) that is based on AD9852 chip. This arm is used to achieve functions of frequency modulation and scanning. The DDS is controlled through serial communication with a computer. The second arm 100 MHz signal is used to phase lock the 6.8 GHz DRO utilizing a sampling PLL. The phase locked DRO is labelled as PLDRO. The 6.8 GHz output signal of the PLDRO is passed through a microwave isolator (Fairview, FMIR1021) to prevent the microwave signal from being reflected back into the PLDRO. The output signal of the PLDRO is then mixed with the 34.68 MHz output signal of the DDS with a mixer (Mini-Circuits, ZX05-83+) to generate the final 6.835 GHz output signal. Benefiting from the sampling PLL, the DRO is directly phase locked to the 100 MHz OCXO. Therefore, the structure of the synthesizer is very simple, and the cost of the synthesizer is low.

The schematic of the sampling PLL is shown in Fig. 2. The sampling phase detector is the key component of the PLL. The sampling phase detector is mainly consisted of a step recovery diode (SRD) and a pair of Schottky diodes. The maximum output frequency of the phase detector can reach 18 GHz. The input impedance of the SRD is usually about 4 - 10 Ω , but the output impedance of the 100 MHz OCXO is 50 Ω . Thus, we design an input matching circuit to match their impedances, which is realized by a transformer. In addition for matching impedance, the transformer is also used to convert unipolar pulses into symmetrical pulses. The loop pass filter (LPF) of the sampling PLL is realized by a positive proportional-integral (PI) circuit. A voltage follower behind the sampling phase detector is designed to serve functions of isolation and impedance matching between the sampling phase detector and the LPF, and also as a low pass filter to suppress the high-frequency noise. The scanning circuit is designed to improve the capture range of the PLL and to shorten phase locking time. The volume of the PLDRO is slightly larger than that of a microwave amplifier.

We measure the absolute phase noises of the main output signals of the microwave syn-

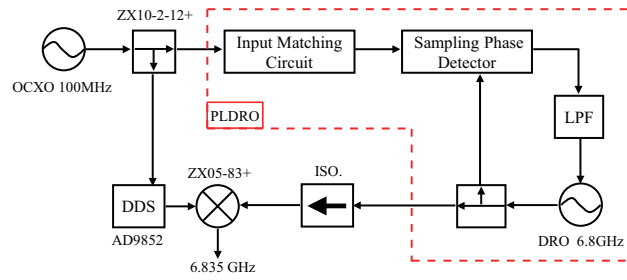

FIG. 1: (Colors online) The architecture of the microwave synthesizer, the part enclosed by the red dashed line is the phase locked DRO, labelled as PLDRO.

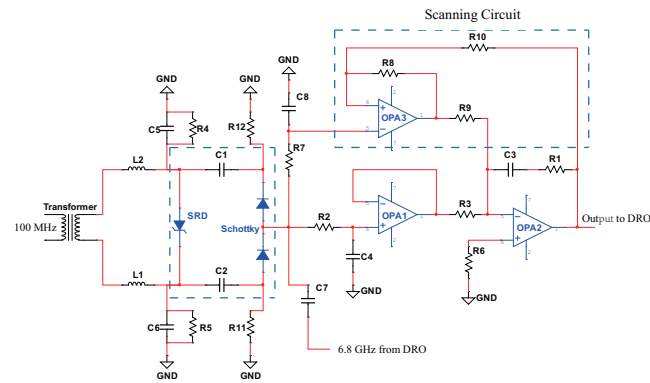

FIG. 2: (Colors online) The detailed schematic of the sampling PLL

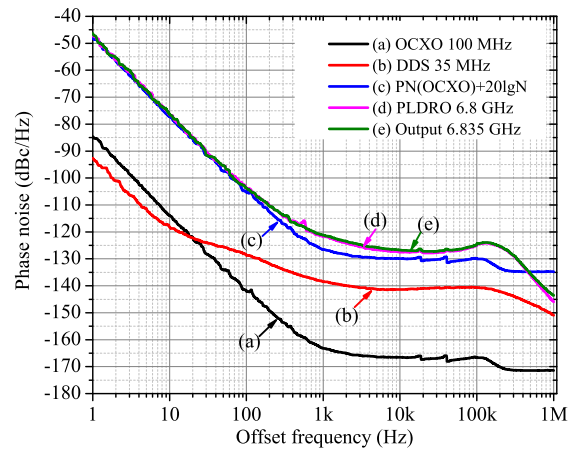

FIG. 3: (Colors online) The absolute phase noises of the main output signals from the microwave synthesizer. The carrier frequencies are at: (a) 100 MHz of the OCXO, (b) 35 MHz of the DDS, (c) 6.8 GHz deteriorated by idealized $20\lg N$ from 100 MHz OCXO, (d) 6.8 GHz of the PLDRO, (e) 6.835 GHz output signal.

thesizer at carrier frequencies of 100 MHz, 35 MHz, 6.8 GHz and 6.835 GHz with a Phase Noise Analyzer (R&S FSWP26 with option 61) using cross-correlation technique for enhanced sensitivity. The noise floor of the FSWP26 with option B61 is shown in Table I (taken from FSWP26 datasheet). The numbers given in Table I is given under the condition of the cross-correlation factor of one ($X_{\text{corr}}=1$). The noise floor can be further lowered with an increasing of X_{corr} , which will not limit measurement accuracy of phase noise. The measured phase noises are shown in Fig. 3. The absolute phase noise of the OCXO 100 MHz has a slight bump at the offset frequencies around 100 kHz, which is inherent in the custom-made free running OCXO. The phase noise of the 6.8 GHz signal of the PLDRO at offset frequencies smaller than 100 Hz is deteriorated by an idealized $20\log N$. At offset frequencies larger than 100 Hz, especially at the offset frequency of locking bandwidth, the maximum phase noise deterioration is increased by an additional 5 dB. This is because the absolute phase noise of free running DRO at small offset frequencies is quite poor. The locking bandwidth of PLL is about 200 kHz. Thus, the gain within the servo loop bandwidth will not be enough. As a consequence, the phase noise, especially at the offset frequencies near the locking bandwidth, cannot be sufficiently suppressed. The phase noise performance of the output 6.835 GHz signal is the same as the phase noise of the PLDRO. The phase noise of the DDS 35 MHz signal is excellent, which do not limit the phase noise of the output 6.835 GHz signal. Using the absolute phase noise of the output 6.835 GHz signal, the short-term frequency stability of the atomic clock is estimated to be better than $5.0 \times 10^{-14} \tau^{1/2}$.

In conclusion, we have developed a simple low phase noise 6.835 GHz microwave synthesizer that is based on the technique of sampling PLL, with the associated low cost. The absolute phase noises of the 6.835 GHz output signal are measured to be -47 dBc/Hz, -77 dBc/Hz, -104 dBc/Hz and -121 dBc/Hz at 1 Hz, 10 Hz, 100 Hz and 1 kHz offset frequencies, respectively. The short-term frequency stability limit due to the absolute phase noise via the intermodulation or the Dick effect is theoretically estimated to be better than $5.0 \times 10^{-14} \tau^{1/2}$. Although our main goal is to develop a simple and low cost microwave synthesizer of 6.835 GHz to be used in Rb atomic clocks, the synthesizer can also be used for Rb atomic fountain clock or in the experiments of the ^{87}Rb Raman atomic interferometers or gyroscopes.^{16,17} By simply changing the output frequencies of the PLDRO and DDS, the scheme can be easily adapted to be used for Cs atomic clocks.

This work was partially supported by the National Key R&D Program of China (Grant No. 2017YFA0304400), the National Natural Science Foundation of China (Grant No. 91336213, 11703031, U1731132 and 11774108) and the Post-doctoral Science Foundation of China (Grant No. 2017M612431).

¹J. C. Camparo, Phys. Today **60**, 33 (2007).

²F. Vannicola, R. Beard, J. White, K. Senior, M. Largay and J. A. Buisson, in proceedings of 42nd PTTI System and Applications Meeting, 181 (2014).

³S. Micalizio, F. Levi, A. Godone, C. E. Calosso and I. Nazionale, in proceedings of IFCS and EFTF, 1 (2015).

⁴T. Bandi, C. Affolderbach, C. Stefanucci, F. Merli, A. K. Skrivervik and G. Mileti, IEEE Trans. Ultrason. Ferroelectr. Freq. Control **61**, 1769 (2014).

⁵Q. Hao, W. Li, S. He, J. Lv, P. Wang and G. Mei, Rev. Sci. Instrum. **87**, 123111 (2016).

⁶C. E. Calosso, A. Godone, F. Levi and S. Micalizio, IEEE Trans. Ultrason. Ferroelectr. Freq. Control **59**, 2646 (2012).

⁷J. Q. Deng, G. Mileti, R. E. Drullinger, D. A. Jennings and F. L. Walls, Phys. Rev. A **59**, 773 (1999).

⁸G. J. Dick, in Proceedings of PTTI **19**, 133 (1987).

⁹A. Joyet, G. Mileti, G. Dudle and P. Thomann, IEEE Trans. Instrum. Meas. **50**, 150 (2001).

¹⁰B. François, C. E. Calosso, J. M. Danet and R. Boudot, Rev. Sci. Instrum. **85**, 094709 (2014).

¹¹Z. L. Chen, J. G. Bohnet, J. M. Weiner and J. K. Thompson, Rev. Sci. Instrum. **83**, 044701 (2012).

¹²F. Ramirez-Martinez, M. Lours, P. Rosenbusch, F. Reinhard and J. Reichel, IEEE Trans. Ultrason. Ferroelectr. Freq. Control **57**, 88 (2010).

¹³R. Boudot, S. Guerandel and E. De Clercq, IEEE Trans. Instrum. Meas. **58**, 3659 (2009).

¹⁴W. B. Li, Y. B. Du, H. Li and Z. H. Lu, AIP Adv. **8**, 095311 (2018).

¹⁵B. François, C. E. Calosso, M. Abdel Hafiz, S. Micalizio and R. Boudot, Rev. Sci. Instrum. **86**, 094707 (2015).

¹⁶Z. K. Hu, B. L. Sun, X. C. Duan, M. K. Zhou, L. L. Chen, S. Zhan, Q. Z. Zhang and J. Luo, Phys. Rev. A **88**, 043601 (2013).

¹⁷Y. B. Du, R. Wei, R. C. Dong, F. Zou, and Y. Z. Wang, *Chin. Phys. B* **24**, 070601 (2015).