

# Charting the Security Landscape of Programmable Dataplanes

Andrei-Alexandru Agape<sup>1</sup> Madalin Claudiu Danceanu<sup>1</sup>  
René Rydhof Hansen<sup>1</sup> Stefan Schmid<sup>2</sup>

<sup>1</sup> Aalborg University, Denmark <sup>2</sup> University of Vienna, Austria

## ABSTRACT

Emerging programmable dataplanes will revamp communication networks, allowing programmers to reconfigure and tailor switches towards their need, in a protocol-independent manner. While the community has articulated well the benefits of such network architectures in terms of flexibility and performance, little is known today about the security implications. We in this position paper argue that the programmable dataplanes in general and P4 in particular introduce an uncharted security landscape. In particular, we find that while some existing security studies on traditional OpenFlow-based networks still apply, P4 comes with several specific components and aspects which change the attack surface and introduce new challenges. We highlight several examples and provide a first systematic security analysis.

## 1 INTRODUCTION

By outsourcing and consolidating the control over network devices to a logically centralized controller and by introducing open interfaces, Software-Defined Networks (SDNs) in general and OpenFlow in particular have enabled great flexibility in how modern communication networks can be managed and operated. However, while OpenFlow is a useful standard in that it allows to control switches from many different vendors in a unified manner, it is still “fixed” as it relies on the assumption that switches have a fixed well-known behavior, as described in the data sheet of the switch ASIC; moreover, the growing support for protocols combined with the fact that OpenFlow only mandates the fields on the packets that one can match upon, but not the actions to be performed after the match, makes it hardly scalable and ambiguous [4].

*Programmable dataplanes* and *P4* [6] promise to fill this gap by offering an open, flexible and silicon-independent API, reconfigurability (the way switches process packets can be changed at runtime), protocol independence (switches are no longer tied to a specific network protocol), and target independence (packet processing functionality can be programmed independently of the specifics of the underlying hardware). Besides a high-level programming language

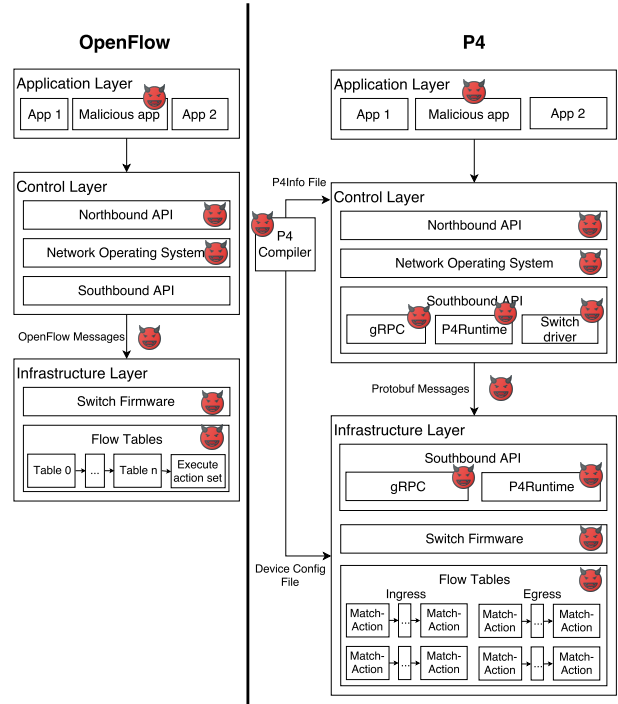
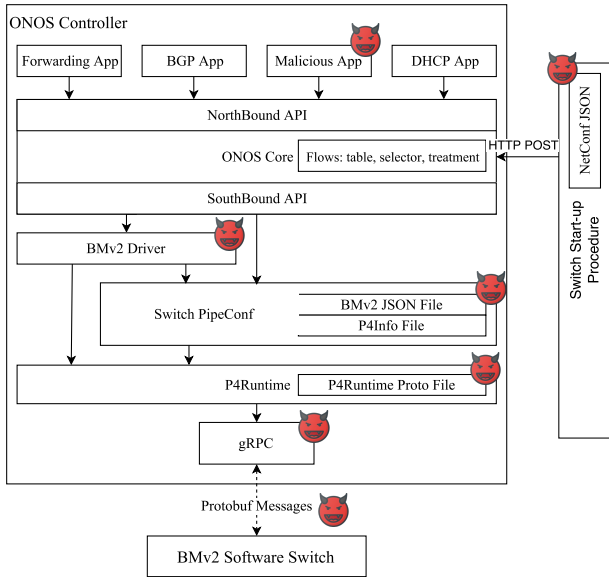

Figure 1: OpenFlow vs P4 attack surface

which can be compiled against many different types of execution machines (called “P4 targets”, which have a P4 compiler back-end), P4 offers a common API (called the *P4 Runtime API*), and allows to change and immediately start using new forwarding tables, without restarting the API or the control plane. The P4 language has no support for specific protocols, rather, the P4 programs are responsible for specifying how a switch processes packets. These programs are then interpreted and processed by the compiled program on the target device.

Our paper is motivated by the observation that programmable dataplanes and P4 do not only enable more flexible communication networks, interesting new use cases, and an unprecedented performance, but also introduce a new attack surface and hence have implications on security. Indeed,



**Figure 2: Overview of P4 components, assets and attack points in ONOS Controller**

while the security of SDN architectures in general and OpenFlow in particular have been explored in different studies in the past, little is known about the security implications of emerging P4 platforms.

**Our Contributions.** This paper observes that programmable dataplanes and P4 change the security landscape, which so far is to a large extent uncharted. Accordingly, we present a first systematic breakdown and approach to study the attack surface and security implications of emerging network architectures supporting programmable packet forwarding. Based on this breakdown, we characterize the possible attack surface of a P4-based SDN environment, highlighting possible attacks and vulnerabilities related to the P4 language and compiler, the controller (exemplified by ONOS), the P4 Runtime, as well as the switches (exemplified by the BMv2 switch). Based on these insights, we discuss how specific attacks and countermeasures can be implemented and report on some experiments. See Figure 1 for an overview of the attack surface and comparison to traditional OpenFlow.

## 2 SECURITY CHALLENGES

In this section we provide a brief overview of the main *assets* of a (typical) P4 SDN environment and a STRIDE analysis of the *attack surface* presented by such an environment.

### 2.1 P4 Assets

To perform our security and vulnerability analysis of P4, we first have to identify and prioritise the potential targets, i.e., the *assets* of the P4 platform. An asset in this context is any

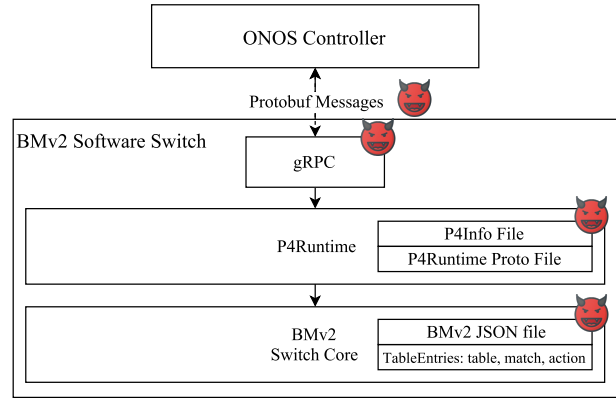

**Figure 3: Overview of P4 components, assets and attack points in BMv2 Switch**

data, device, or other component that supports information related P4 activities. For convenience we have grouped the P4 assets of interest into four general categories: control plane assets, channel plane assets, dataplane assets, and the P4 compiler, see Figure 2 and Figure 3 for an overview. In the following we briefly describe the categories and their concomitant assets.

**Control Plane.** The control plane, as a whole, is concerned with the routing process, including ongoing management and setup of the process.

**Applications.** These are the primary assets in the control plane. An application is (potentially third-party) software designed to manage and perform specific actions within an SDN.

**P4Info.** This is the result of compiling the P4 program. This asset contains critical information such as tables, meters, counter, etc. as well as assigned IDs, enabling communication between controller and switch. This information is also used by both the P4 controller to setup the forwarding configuration and the P4 runtime (denoted *P4Runtime* in Figure 2) for translating IDs into objects.

**P4DeviceConfig.** The result of compiling the P4 control program to the target switch using the appropriate back-end compiler, e.g., *bm2JSON* is the output of *bm2* back-end compiler. This asset is used by the controller, together with the *P4Info*, to set up the forwarding plane configuration.

**SwitchPipeConf.** This is a controller application that defines the switch pipeline by using the *P4Info* and *P4DeviceConfig* assets to set up a mapping between P4 and platform specific objects.

**Switch driver.** The switch driver is a switch-specific application running on the controller and typically developed by the switch vendor. It provides an interface for adding and removing target specific table entries using the mapping

set up by *SwitchPipeConf*. As an example, in ONOS, it maps ONOS flows to P4 table entries.

**P4Runtime agent.** This is an application on the controller that serializes the P4 objects and the forwarding configuration to *Protobuf* and calls the intended RPC methods.

**P4Runtime.proto.** The *P4Runtime* protocol specification. It defines the RPC methods and messages that can be used between controller and switch. The protocol provides different RPC methods such as *SetForwardingPipeliningConfig* and *StreamChanel*. On top of these, the protocol provides a multitude of message types. The *P4Runtime.proto* is present in both controller and switch.

**gRPC.** The Remote Procedure Call (RPC) system developed at Google. It uses HTTP/2 for transport, *Protocol Buffers* as the interface description language, and provides features such as authentication, bidirectional streaming and flow control, cancellation and timeouts etc.

From the above, it should be clear that the control plane contains a wide variety of assets, ranging from applications to simple files, resulting in a wide attack surface.

**Channel Plane.** The channel plane is concerned with inter-component communication (through channels), mainly between controller and switch. For our use, this plane comprises only a single asset:

**Protobuf messages.** These are the messages exchanged between the controller and switch, serialized using Protocol Buffers.

**Dataplane.** The dataplane is concerned with the actual forwarding of data (packets) and shares (some) asset types with the control plane.

**gRPC.** This is similar to the *gRPC* asset on the controller, with the difference that if the switch *gRPC* is not available it is only the switch that cannot be controlled anymore, while if the controller *gRPC* is not available, the whole network becomes uncontrollable.

**P4Runtime.proto.** The *P4Runtime* protocol specification that defines the RPC methods and messages that can be used between controller and switch. Similar to the file present on the controller.

**Parser/de-parser.** These are defined in the P4 program as a deterministic finite automaton (DFA) using states and transitions.

**Flow tables.** These are the tables used to define exactly how the packets are forwarded and processed.

**Compiler.** The compiler is a key asset on the P4 platform: this is what enables the rapid development of applications that can change major aspects of a network. However, as with all programming, this also comes with many potential risks requiring good (security aware) programming practices. For our purposes, we consider different parts of the compiler as separate assets.

**Front-end compiler.** This is a target-independent and standard part of the compiler that deals with the semantics checks, and that can be combined with a target-specific back-end to create a complete P4 compiler. We here take the front-end compiler to include various optimization passes, performed before the generated *Intermediate Representation* (IR) is sent to the back-end compiler.

**Converter (P4-14 to P4-16).** This part of the compiler enables backward compatibility with the P4-14 version of the P4 language. It parses the P4-14 into version 1 of the Intermediate Language before it is converted to the *Intermediate Representation* accepted by the back-end.

**Back-end compiler.** This is the main target-specific component of the compiler, usually developed by the vendor of the network components.

With this we conclude the survey of the P4 assets we have identified. It is possible to identify even more specific assets, but for an initial mapping of major (potential) security vulnerabilities, we have found that the above lists provide a good starting point.

## 2.2 STRIDE Analysis and Attack Surface

We now present a STRIDE analysis of the P4 platform, based on the assets identified in the previous section. STRIDE [7] is a well-known model for categorising (potential) IT-security threats and a useful tool for structuring threat-analysis of IT systems. The name is a mnemonic derived from the threat categories comprising the model: *Spoofing*, *Tampering*, *Repudiation*, *Information disclosure*, *Denial-of-service*, and *Elevation of privilege*. The threat categories cover most, if not all, the “classic” threats/attacks that have been observed and reported in the literature.

Since STRIDE analysis is fairly standard and well-known, we will not discuss it in further detail here. We illustrate the general methodology by briefly discussing an excerpt of the STRIDE analysis for the *P4Runtime* component (see Table 1 for an overview).

**Spoofing.** A potential spoofing attack would be an attacker (successfully) masquerading as a (different) switch in the network. This would allow the attacker to elicit information from the controller, such as de-/parser configuration, pipeline configuration, forwarding table entries, and how table-miss flows are handled.

**Tampering.** If an attacker can modify, i.e., tamper with, protobuf messages can violate both confidentiality, integrity, and availability properties of the network. An attacker that can take control of the switch *gRPC* or the controller *gRPC*, can modify the sent and received protobuf messages, thus controlling the switch or the entire network.

**Repudiation.** In a *repudiation* attack, an attacker can make the switch refuse configurations from controller and

**Table 1: STRIDE analysis**

Threat	Property violated	Definition	Example
Spoofing	Authentication	Impersonating something or someone else	Pretends to be another switch in the network
			Pretends to be the controller
			Pretends to be the network controller administrator
Tampering	Integrity	Modifying data or code	Intercept and modify protobuf messages
			Take control of gRPC server and modify the protobuf messages
Repudiation	Non-repudiation	Claiming to have not performed an action	A switch that does not follow the controller instructions
			A controller claiming that a switch has not connected to it
Information Disclosure	Confidentiality	Exposing information to someone not authorized to see it	Read device tables: controller flows, switch tables
			Read protobuf messages
			Crashing the P4Runtime gRPC service
Denial of Service	Availability	Deny or degrade service to users	Flooding the switch-controller channel
			Modify and invalidate protobuf messages
			Intercept and deny arrival of the packets to the intended device
			A switch changing information in the controller
Elevation of privilege	Authorization	Gain capabilities without proper authorization	Configure a switch and decide how the traffic is handled

claim they were not received, thus making the switch uncontrollable. An attacker can make the controller refuse connections from switches that try to connect to it and claim that no connection were instantiated, rendering the switch unable to handle traffic.

**Information disclosure.** An attacker with a presence on the network may be able to pick up information that is either sent in the clear, such as unencrypted protobuf messages, messages picked up directly from the control plane, or even exploiting specific timing properties for an advanced timing-attack on the controller or the switches.

**Denial-of-service.** A *denial-of-service attack* may crash the *gRPC* service, making the communication between the switch and the controller unavailable, potentially wrecking havoc in the network.

**Elevation of privilege.** As part of an *elevation of privilege*, an attacker can write malicious applications, and based on the controller configuration, allow it to read, modify or deny data and services. It may also modify the forwarding tables.

To obtain a high-level overview of a system’s security stance, it is often useful to consider the system’s *attack surface*. In general, the attack surface of a system is the sum of the different points (“attack vectors”) where an unauthorized user (“attacker”) can try to enter data to or extract data from an environment [5]. Here, the attack surface is composed of: (1) the data in the system and messages exchanged, (2) the methods for processing applications, e.g., request/response methods, (3) the communication channels, e.g., HTTP, TCP.

### 3 P4 LANGUAGE AND COMPILER

The main components of the P4 language compiler are the parser (either P4-14 or P4-16), an IR converter that enables backwards compatibility with the P4-14 language, a fixed front-end component, customizable mid-ends, and back-ends provided by the vendor for specific targets. Since the front-end and mid-end are standard and mostly fixed, bugs and/or vulnerabilities at this level can generate incorrect IR for all back-ends that are using them. Even though an attacker may not be able to directly modify the P4 programs, the source code of the front-end compiler and the language specifications can be found on the official websites and repositories.

**P4 compiler fuzzer.** One option the attacker has is to write P4 programs that can either crash the compiler, generate invalid target code or target code that is not following the original intentions. In order to automatically generate random test-cases, a compiler fuzzer [8] can be implemented.

**Race conditions.** Another interesting and novel attack may involve the use of *concurrency*, i.e., an attacker may try to find out whether the race conditions are handled correctly. In fact, *the extern blocks instantiated by a P4 program are global, and shared across all threads; if extern blocks mediate access to state (e.g., counters, registers) [...] these stateful operations are subject to data races.* [1]. There are tools for the automatic detection of race conditions, such as *RaceMob*, *RaceFuzzer* and *RaceChecker*, however, currently none exist for P4.

**P4-14 to P4-16 converter.** Because of its backward compatibility with P4-14, the P4C introduces another point of attack in the sense of the P4-14 to P4-16 converter. Bugs or vulnerabilities in the converter can introduce another class of problems related to the P4-14 version of P4 programs. Using a compiler fuzzer to generate P4-14 programs can be one way to find bugs in the converter. Other vulnerabilities can be related to the converter parallel actions. An example of such a bug has been reported to the official repository (Issue 246) and it is still not clear if it was solved due to the P4 1.1 language specification being ambiguous.

**P4 language benchmark.** As presented earlier the back-end compiler is target specific, therefore multiple compilers are being developed without a clearly defined standard. While the benchmark proposition could help creating a standard for the P4 compilers, it should be built and adopted by the whole community, which e.g., is not the case of *Whippersnapper* [2], or at least not yet. Currently four sample backends are available on the P4Lang repository: *p4c-bm2-ss*, *p4c-ebpf*, *p4test* and *p4c-graphs*; the latter two are used for debugging and generating graphs of top-level control flows.

**Undefined behaviour.** One possible attacking point is represented by the P4 language specifications, more precisely the “Undefined behavior” chapter. As stated in this chapter “there are a few places where evaluating a P4 program can

result in undefined behaviors: out parameters, uninitialized variables, accessing header fields of invalid headers, and accessing header stacks with an out of bounds index”. An attacker can find code patterns that have a vulnerability potential by making use of the undefined behavior. In this sense, the new programmable switches have exploitability potential if the undefined behaviour is handled differently by some compilers compared to others.

**ASSERT-P4.** Assertion-based verification [3] can be used to check general security and correctness properties of P4 programs. From an attacker point of view, the tool can also be used to find vulnerabilities in open-source P4 applications. ASSERT-P4 is a tool designed in this sense that can be used to annotate the P4 programs with assertions, translate it to a C-based model and verify it using a symbolic execution engine. The engine tests all possible paths and reports any assertion failure.

Table 2 and Table 3 summarizes the attacks and countermeasures regarding the P4 language and compiler.

## 4 CASE STUDY: ONOS AND BMV2

To illustrate our general security analysis and make it more concrete, we here consider three specific examples from the ONOS project, namely the ONOS controller, the ONOS P4 Runtime, and the BMv2 Switch.

### 4.1 The ONOS Controller

Analysing the ONOS controller is particularly interesting, as it is currently also modified to support P4. The ONOS controller runs on top of a Java Virtual Machine and is mainly used to alter the tables entries on the controlled devices in the network in order to properly manage the network during its operation.

**Malicious applications.** Malicious applications can disclose confidential information, slow down the service or even crash the controller. ONOS runs as a single process including all its internal components and also the installed and active applications. Consequently, an attacker can crash the controller by simply closing that process, which would not only close the application but the entire ONOS controller.

**Controller configuration.** Another type of attack could exploit the fact that networks are changing continuously, with devices being removed, added, or crash. The controller has to be configured properly and have the right applications running in order to support such churn. The complexity of the required configurations (related to encryption, usage of strong credentials, only activating the features that are required for the specific network, and so on) may introduce errors and increase the attack surface. One example of such a configuration is that ONOS Command Line Interface (CLI) has a default insecure client (Apache Karaf) since it relies on

a well-known private key. Installing the security countermeasure (onos-secure-ssh) as described in the documentation is not working due to it being outdated. The fact that some versions of ONOS have the Security-mode disabled by default, and enabling it can be a tedious process, contributes also to the overall security.

**Authentication.** Access to the CLI, Web GUI, or the REST API is done through authentication. While the ONOS CLI uses public/private key authentication, the GUI and the REST API require username/password credentials. The brute-force type of attacks exploit the fact that users often use simple enough combinations of username and password.

Table 2 and Table 3 summarizes the attacks and countermeasures regarding the controller.

### 4.2 The P4 Runtime

We identify two main vulnerabilities which regard the P4 Runtime (both the Java ONOS controller and the C++ BMv2 switch): a man-in-the-middle attack and channel flooding.

**Man-in-the-middle.** A man-in-the-middle attack requires that the adversary has access to the channel through which important packets travel. This type of attack is particularly relevant in the context of P4 programmable switches with P4Runtime support because the gRPC messages communicated on the channel between the switch and the controller, containing much sensitive information: e.g., switch configuration files, the tables available, and other control messages altering the table entries. The information captured by the adversary can be used for other types of attacks such as spoofing. Also worth mentioning is the fact that if the switch sends the packets that do not match any tables to the controller, the adversary is also able to capture these messages which could contain sensitive information such as credentials or other personal information. Even though the messages are serialized into binaries using protobuf, they are not encrypted and can be deserialized by using the protobuf compiler. The deserialization process requires the P4Runtime protocol specification for protobuf and the P4 program information file containing the IDs for tables and other P4 objects. The P4Runtime protocol specification can be easily obtained since it is publicly available while the P4Info file can be obtained by listening for the initial start-up process of the switch when this file is transmitted from the controller to the switch.

**Channel flooding.** In the context of P4 programmable switches controlled using the P4Runtime protocol there is a single P4Runtime agent in the controller while each switch has its own P4Runtime agent. Thus flooding the channel with packets from one or multiple switches in the network can lead to slower response time or even denial of service of the P4Runtime agent in the controller. The attack can be

**Table 2: Attacks**

Legend: ○= Low, ◐= Medium, ●= High

Name	Component	Impact	Difficulty
Exploiting Undefined Behaviour	Compiler	◐	◐
Exploiting Concurrency	Compiler	◐	◐
Assertion based verification	Compiler	◐	●
Malicious application	Controller	●	◐
Exploiting misconfiguration	Controller	●	◐
Login brute-force	Controller	●	◐
Man-in-the-Middle	P4 Runtime	●	◐
Channel flooding	P4 Runtime	●	◐
Spoofing the controller	Switch	●	●

conducted in both directions: e.g., the controller, probably through a rogue application, may flood the switches with many control messages in order to affect the behavior and response time of the network.

Tables 2 and 3 summarize the attacks and countermeasures regarding the P4 runtime.

### 4.3 The BMv2 Switch

There are also potential vulnerabilities on the switch side. For example, the BMv2 Switch with P4Runtime support has its tables populated and altered by the controller through remote procedure calls with messages serialized using the protobuf protocol. This fact can be exploited by an adversary by sending control messages to the switch as if these messages originate from the controller. In order for the adversary to be able to perform such an attack, it needs to be able to serialize messages using the protobuf protocol for sending the information wanted to the switch. For serializing the data the attacker needs to possess some knowledge regarding the switch such as the description of the tables together with their assigned ids which are contained in the P4Info file as well as the switch behavior description which is located in the compiled BMv2 JSON config file. The attacker can obtain this information by using other attacks such as the man-in-the-middle attack. By spoofing the controller, an attacker can alter the table entries in the switches completely changing the behavior of the devices. This can be used to bypass firewalls or change the configuration of the devices in a such a way that would somehow benefit the adversary. Table 2 and Table 3 summarize the attacks and countermeasures regarding the switch.

**Table 3: Countermeasures**

Legend: ○= Low, ◐= Medium, ●= High

Name	Component	Impact	Difficulty
Assertion based verification	Compiler	◐	●
Compiler fuzzer	Compiler	●	●
Whippersnapper benchmark	Compiler	○	◐
ONOS secure mode	Controller	●	○
Symbolic Execution Analysis	Controller	◐	●
Brute-force protection	Controller	◐	○
Securing the channel	P4 Runtime	●	○
Reactive firewall application	P4 Runtime	●	◐

## 5 CONCLUSION

One may argue that at least the security of SDNs and Open-Flow is fairly well-understood today, and indeed, many existing known weaknesses and vulnerabilities, as well as countermeasures known from SDN architectures in general also directly apply to P4. Yet, in this paper we have shown that P4 architectures in general and programmable dataplanes in particular come with many specific properties that have the potential to change the security landscape and, as we argue, require special attention.

## REFERENCES

- [1] The P4 Language Consortium. 2017. *P416 Language Specification*. Accessed: 2017-11-15.
- [2] H.T. Dang et al. 2017. *Whippersnapper: A P4 Language Benchmark Suite*. Proc. ACM SOSR.
- [3] L. Freire et al. 2018. Uncovering Bugs in P4 Programs with Assertion-based Verification. In *Proc. ACM SIGCOMM SOSR*.
- [4] Lightreading. 2017. P4 runtime: Putting the control plane in charge of the forwarding plane. In *Online resource*.
- [5] Pratyusa K. Manadhata. 2008. An Attack Surface Metric. <http://reports-archive.adm.cs.cmu.edu/anon/2008/CMU-CS-08-152.pdf>. (2008).
- [6] P. Bosshart et al. 2014. P4: Programming protocol-independent packet processors. *ACM SIGCOMM CCR* (2014).
- [7] R. Kloti et al. 2013. Openflow: A security analysis. In *Proc. IEEE ICNP*.
- [8] Y. Chen et al. 2013. Taming compiler fuzzers. In *ACM SIGPLAN Notices*.