

# Fault-tolerant switching between generic stabilizer codes

Cupjin Huang<sup>1</sup> and Michael Newman<sup>2</sup>

<sup>1</sup>Department of Electrical Engineering and Computer Science

<sup>2</sup>Department of Mathematics

University of Michigan, Ann Arbor, MI 48109, USA

cupjinh@umich.edu, mgnewman@umich.edu

## Abstract

The stabilizer rewiring algorithm (SRA) recently proposed in [5] gives a method for constructing a transversal circuit mapping between any pair of stabilizer codes. As gates along this circuit are applied, the initial code is deformed through a series of intermediate codes before reaching the final code. The circuit is then fault-tolerant if the full set of intermediate codes have high distance. We propose a randomized variant of the SRA and show that with at most linear overhead, there exists a path of deformations which preserves the code distance throughout the circuit. Furthermore, we show that a random path will almost always suffice, and so the circuit can be constructed explicitly using the SRA. This allows constructive, low overhead fault-tolerant code switching between arbitrary stabilizer error-correcting codes.

## 1 Introduction

It is an oft-cited fact that no quantum error-correcting code can implement a universal transversal logical gate set [7, 15, 10]. As a result, there have been several attempts to circumvent this no-go theorem to achieve universal fault-tolerant quantum computation. These candidates include magic state distillation [8, 4], gauge fixing [11, 3], and more recently pieceable fault tolerance [14, 13]. These last two candidates can be seen as a special case of the more general approach of code switching [9, 2].

Code switching is a natural idea: given two codes, map information encoded in one code to information encoded in the other. In order for this mapping to be fault-tolerant, we must often perform several intermediate error-correction steps to ensure that faults do not grow out of hand. Thus, it is essential that during a circuit switching between codes, the extremal error-correcting codes are deformed through a series of intermediate error-correcting codes from one to another. This notion of intermediate error-correction was used in [2] to implement universal transversal computation by switching between the Steane and Reed-Muller codes, whose complementary transversal gate sets are universal when taken together.

However, universal fault-tolerant computation is not the only consideration in choosing error-correcting codes, and different codes can be tailored to different tasks. For example, some codes are better served as quantum memories while others are better for fault-tolerant processing, while others still are resistant against certain types of asymmetric noise. For this reason, it would be nice to have a way of converting between different quantum codes fault-tolerantly.

Simply decoding and re-encoding information is undesirable, since the bare information becomes completely unprotected during this transformation. Past work has succeeded in constructing fault-

tolerant circuits for switching between particular quantum error-correcting codes fault-tolerantly, while providing guarantees that these circuits are optimal [2].

Recently, [5] considered the generic code switching case, and proposed the stabilizer rewiring algorithm (SRA) for constructing a transversal circuit mapping between *any* pair of stabilizer codes. The algorithm has low overhead, requiring at most  $4n^2$  gates in total (and often significantly fewer). Furthermore, the SRA depends on a choice of presentation for the code generators, and different presentations will result in different circuits mapping between different sets of at most  $n$  intermediate codes. This circuit fails to be fault-tolerant when these intermediate codes have low distance. This leads to the central question: *is there an efficient way of fault-tolerantly converting between generic stabilizer codes?*

## 1.1 Results

In this work, we propose a randomized variant to the SRA, the randomized SRA (rSRA). We show that for any pair of stabilizer codes, with at most linear overhead with respect to the length of the codes, there always exists a fault-tolerant circuit mapping between these codes. Furthermore, using slightly more overhead, such a path can be found with high probability. In particular, we show the following.

**Theorem 1.1** (Informal). *For any two  $[[n, k, d]]$  stabilizer codes  $S_1$  and  $S_2$ , the rSRA scheme gives a transversal circuit mapping from  $S_1$  to  $S_2$  where each intermediate code has distance at least  $d$  with probability  $1 - \varepsilon$ , using*

$$m = O\left(d \log \frac{n}{d} + d + \log \frac{1}{\varepsilon}\right)$$

*ancilla qubits.*

This gives a universal upper bound on the number of ancilla qubits required for fault-tolerant code transformation. As was noted in [5], the usefulness of this scheme is in its generality.

## 1.2 Organization

In Section 2 we detail some preliminaries and notation that will be used throughout the paper. The main rSRA schematic is presented in Section 3. Some examples illustrating different parts of the rSRA are presented in Section 4. The proof of the main theorem is presented in Section 5. Some discussion and possible improvements for the rSRA can be found in Section 6. Readers interested in the technical details may refer to the appendices for additional lemmas.

## 2 Preliminaries

Let  $\mathcal{P}^n$  denote the  $n$ -qubit Pauli group. Then a *stabilizer group*  $S \subseteq \mathcal{P}^n$  is an abelian subgroup of the Pauli group not containing  $-I$ . To any such stabilizer group  $S$ , we can associate a subspace  $C_S \subseteq (\mathbb{C}^2)^{\otimes n}$  defined as the simultaneous  $+1$ -eigenspace of all the operators in  $S$ . We call such a subspace  $C_S$  a *stabilizer code*.

A stabilizer code  $C_S$  has parameters  $[[n, k, d]]$ . Here,  $n$  is the number of physical qubits comprising the code,  $k$  is the number of logical qubits of the code  $\log(\dim(C_S))$ , and  $d$  is the distance of the code. More precisely, the normalizer  $\mathcal{N}_{\mathcal{P}^n}(S)$  represents the set of logical Pauli operators for  $C_S$ , and so

$$d := \min_{L \in \mathcal{N}(S) \setminus S} (|L|)$$

where  $|\cdot|$  denotes the weight of the Pauli operator. Note that the number of stabilizer in the corresponding stabilizer subgroup is  $n - k$ .

Given any stabilizer group  $S$ , if we choose a generating set  $G_S$  for  $S$ , we can define a syndrome map

$$\begin{aligned} \text{Syn}_G : \mathcal{P}^n &\longrightarrow \{0, 1\}^{n-k} \\ \text{Syn}_G(e)_i &= \begin{cases} 0 & \text{if } [e, g_i] = 0 \\ 1 & \text{if } \{e, g_i\} = 0 \end{cases} \end{aligned}$$

for  $G = (g_1, \dots, g_{n-k})$ . Then equivalently,

$$d = \min_{L \in \ker(\text{Syn}_G) \setminus S} (|L|)$$

and is independent of the choice of  $G$ .

Another convenient formalism for describing stabilizer groups is as subspaces of symplectic vector spaces, and we will use the two formulations interchangeably. For any  $P \in \mathcal{P}^n / \mathcal{U}(1)$ , if

$$P = X^{a_1} Z^{b_1} \otimes X^{a_2} Z^{b_2} \dots \otimes X^{a_n} Z^{b_n}$$

then we can associate to  $P$  the vector  $\vec{P} := (\vec{a} | \vec{b})^T \in \mathbb{F}_2^{2n}$ . Equip  $\mathbb{F}_2^{2n}$  with a symplectic bilinear form

$$\langle \vec{v}, \vec{w} \rangle := \vec{v}^T B \vec{w}$$

where  $B$  is the  $2n \times 2n$  block matrix defined by

$$B = \begin{pmatrix} 0 & I \\ I & 0 \end{pmatrix}.$$

Then Paulis  $P, Q$  commute if and only if their associated vectors  $\vec{P}, \vec{Q}$  are orthogonal in this vector space. Thus, we can equivalently define a stabilizer group as a self-orthogonal subspace of this vector space. A *generator matrix*  $G$  is then a choice of basis for this subspace, so that for  $C$  an  $[[n, k]]$  code,  $G$  will be a rank  $(n - k)$  matrix of shape  $2n \times (n - k)$ . The syndrome map can then be similarly defined as

$$\text{Syn}_G(\vec{P}) = G^T B \vec{P}.$$

Further note that for any  $A \in GL(\mathbb{F}_2, n - k)$ , for any generator matrix  $G$  for  $S$ ,  $GA^T$  is also a generator matrix for  $S$ . The syndrome map satisfies

$$\text{Syn}_{GA^T}(\vec{P}) = (GA^T)^T B \vec{P} = AG^T B \vec{P} = A \cdot \text{Syn}_G(\vec{P}).$$

So any action on the generator matrix induces a corresponding action on the syndrome vectors themselves.

Finally, we call a circuit  $C$  on a class of encoded inputs *t-fault-tolerant* if it is  $t$ -fault-tolerant in the exRec formalism [1]. Formally, given error correction procedure  $EC$ ,  $C$  is  $t$ -fault-tolerant if for any choice of  $t$  faulty components in the combined circuit  $EC \cdot C \cdot EC$ , a faultless version of  $EC$  applied to the output of the combined circuit can successfully recover the data. If  $t \geq 1$  we may simply call the circuit fault-tolerant.

### 3 The rSRA schematic

We now define the rSRA, which follows the SRA presented in [5], but with some modifications. The central insight to the SRA is the following. Consider two stabilizer groups  $S, S'$  with generating sets  $G, G'$  satisfying the following nice property:

$$\begin{aligned} G &= \{g, g_1, \dots, g_l\} \\ G' &= \{g', g_1, \dots, g_l\} \end{aligned}$$

where  $\{g, g'\} = 0$ . We call two such codes for which one can choose such generating sets *adjacent*. Then one can readily check that the Clifford gate  $\frac{1}{\sqrt{2}}(1 + g'g)$  maps information encoded in the stabilizer code defined by  $G$  to the same information encoded in the stabilizer code defined by  $G'$ . Letting  $|\psi\rangle_A$  denote a logical state in the code associated to  $A$ , we see that

$$\begin{aligned} g_i \cdot \frac{1}{\sqrt{2}}(1 + g'g)|\psi\rangle_G &= \frac{1}{\sqrt{2}}(1 + g'g)|\psi\rangle_G, \text{ and} \\ g' \cdot \frac{1}{\sqrt{2}}(1 + g'g)|\psi\rangle_G &= \frac{1}{\sqrt{2}}(g' + g)|\psi\rangle_G \\ &= \frac{1}{\sqrt{2}}(g' + 1)|\psi\rangle_G \\ &= \frac{1}{\sqrt{2}}(1 + g'g)|\psi\rangle_G. \end{aligned}$$

The insight is that this mapping can be done transversally, and so the whole process can be done fault-tolerantly. While the Clifford transformation described need not be transversal, it can be simulated by a transversal Pauli measurement supplemented by a transversal Pauli gate controlled on classical information. This is similar to gauge-fixing, in which one measures a logical operator of the gauge and then applies a corresponding logical gauge operator conditioned on the outcome. To see this, consider the circuit described by:

1. Measure  $g'$ .
2. Apply  $g$  conditioned on measurement outcome  $-1$ .

Let  $P^\pm$  denote the projector onto the  $+1/-1$  eigenspace of  $g'$ . Then, if the measurement outcome is  $+1$ ,

$$\frac{1}{\sqrt{2}}(1 + g'g)|\psi\rangle_G = \frac{1}{\sqrt{2}}(1 + g')|\psi\rangle_G = \sqrt{2}P^+|\psi\rangle_G.$$

If the measurement outcome is  $-1$ ,

$$\begin{aligned} \frac{1}{\sqrt{2}}(1 + g'g)|\psi\rangle_G &= \frac{1}{\sqrt{2}}(g - gg')|\psi\rangle_G \\ &= \frac{1}{\sqrt{2}}g(1 - g')|\psi\rangle_G \\ &= \sqrt{2}gP^-|\psi\rangle_G \end{aligned}$$

Thus, we see that we can *transversally* perform the mapping  $|\psi\rangle_G \rightarrow |\psi\rangle_{G'}$ .

Now consider the more general case in which we have (non-adjacent)  $S, S'$  describing  $[[n, k]]$  and  $[[n', k]]$  codes respectively. We now describe a general randomized algorithm for outputting a circuit switching between these two codes, similar to [5], and will later show that this circuit is fault-tolerant with high probability. The inputs are arbitrary  $G, G'$  for  $S, S'$ , along with a choice of  $m \in \mathbb{N}$ .

### Preparing the generator matrices

1. Append  $|0\rangle$  ancilla to the smaller code so that the codes are of equal size. We now assume that both codes are  $[[n, k]]$  codes.
2. Append  $|0\rangle^{\otimes m}$  to the first code, and  $|+\rangle^{\otimes m}$  to the second. Note that this is equivalent to defining a pair of new stabilizer codes

$$\hat{S} = \langle S \otimes I^{\otimes m}, I^{\otimes n} \otimes Z \otimes I^{\otimes m-1}, \dots, I^{\otimes n+m-1} \otimes Z \rangle,$$

$$\hat{S}' = \langle S' \otimes I^{\otimes m}, I^{\otimes n} \otimes X \otimes I^{\otimes m-1}, \dots, I^{\otimes n+m-1} \otimes X \rangle.$$

3. Choose  $G_A = G'_A$  to be a basis for the subspace defined by  $\hat{S} \cap \hat{S}'$ .
4. Choose  $G_B$  to extend the basis of  $G_A$  to a basis for  $\mathcal{N}(\hat{S}') \cap \hat{S}$  and choose  $G'_B$  to extend the basis of  $G_A$  to a basis for  $\mathcal{N}(\hat{S}) \cap \hat{S}'$ .
5. Choose  $G_C$  to extend the basis  $G_A \cup G_B$  to a basis for  $\hat{S}$  and  $G'_C$  to extend the basis  $G'_A \cup G'_B$  to a basis for  $\hat{S}'$ .
6. Let  $H$  be the *commutativity matrix* for  $G_C, G'_C$  defined by  $H := G'_C{}^T B G_C$ . By Lemma A.2,  $H$  is invertible with dimension  $|G_C| \times |G_C|$ , where  $|G_C| \geq m$ . So we can choose  $M, N \in GL(\mathbb{F}_2, |G_C|) : M^T H N = I_{|G_C|}$  and redefine

$$G_C \leftarrow G_C \cdot M$$

$$G'_C \leftarrow G'_C \cdot N.$$

7. Choose uniformly at random  $V, V' \in_r \mathbb{F}_2^{|G_C| \times |G_B|}$  and a  $U \in_r GL(\mathbb{F}_2, |G_C|)$ .
8. Redefine

$$G_C^T \leftarrow U(V G_B^T + G_C^T)$$

$$G'_C{}^T \leftarrow (U^{-1})^T (V' G'_B{}^T + G'_C{}^T)$$

Note that this does not change the commutativity matrix since

$$U(V G_B^T + G_C^T) B (G'_C + G'_B V'^T) U^{-1} = U G_C^T B G'_C U^{-1} = I_{|G_C|}.$$

9. Let  $G_B = \{g_1, \dots, g_{|G_B|}\}$  and  $G'_B = \{g'_1, \dots, g'_{|G'_B|}\}$ . For each  $g_i \in G_B$ , choose  $\bar{g}_i$  satisfying

$$\begin{aligned}
[\bar{g}_i, G_A] &= 0 \\
[\bar{g}_i, G_C] &= 0 \\
[\bar{g}_i, G'_C] &= 0 \\
[\bar{g}_i, \{g_{i+1}, \dots, g_{|G_B|}\}] &= 0 \\
[\bar{g}_i, \{g'_{i+1}, \dots, g'_{|G_B|}\}] &= 0 \\
[\bar{g}_i, \{\bar{g}_1, \dots, \bar{g}_{i-1}\}] &= 0 \\
\{\bar{g}_i, g_i\} &= 0 \\
\{\bar{g}_i, g'_i\} &= 0.
\end{aligned}$$

To see that such a choice of  $\bar{g}_i$  always exists, note that it must satisfy at most  $2n$  affine linear equations, all of which are linearly independent, in a space of dimension  $2n$ .

We have now prepared the generator matrix for applying the SRA, which will step-by-step map between adjacent codes transversally.

### Applying the transformation

10. For  $1 \leq i \leq |G_B|$  indexing the elements of  $G_B$ , perform the transformation  $g_i \mapsto \bar{g}_i$ . Note that the resulting stabilizer codes are adjacent, and so the preceding discussion gives a transversal circuit for each mapping.
11. For  $1 \leq i \leq |G_C|$  indexing the elements of  $G_C$ , perform the transformation  $g_i \mapsto g'_i$ . Again, since the codes are adjacent, the mapping can be done transversally.
12. For  $1 \leq i \leq |G_B|$  indexing the elements of  $G'_B$ , perform the transformation  $\bar{g}_i \mapsto g'_i$  starting from  $i = |G_B|$  and working backwards towards  $i = 1$ . Again, we have a transversal circuit for each mapping.
13. Discard the ancilla.

This randomized variant differs from the original SRA in several ways. First, there is the introduction of ancilla, which we will see are vital for achieving fault-tolerant code switching.

Next, the SRA fixes the generating sets  $G, G'$  subject to the same  $G_A$  and  $G_C$  conditions, but with different  $G_B$  conditions. Namely, the SRA fixes the  $\bar{g}$  to be the product of the complementary logical operators to those operators in  $G_B$  and  $G'_B$ , which can be seen as nontrivial logical operators on the opposite code. This allows for a certain degree of freedom in choosing the order in which one converts between the two codes, but restricts the  $G_C, G'_C$  that are available to use.

Also in the SRA, only the set of valid permutations among  $G_B$  and  $G_C$  are considered, which sometimes prevents the existence of a fault-tolerant mapping. In the rSRA, we consider the full set of invertible transformations on  $G_C$  for a better chance of success.

Finally, the transformation described above is *symmetric* in the sense that switching from  $G$  to  $G'$  or  $G'$  to  $G$  beginning at step 10 results in the same set of intermediate codes. We will see that this simplifies the set of errors we must consider.

## 4 Fault-tolerance for small codes

We have now described a way of constructing a transversal circuit mapping information encoded in  $G$  to information encoded in  $G'$ . Using Shor-style fault-tolerant measurement (see Appendix B), if we can perform intermediate error-correction procedures after each step of the algorithm, this will ensure that the entire circuit is fault-tolerant. This is desirable: if we're not concerned with fault-tolerance, we could simply decode and re-encode the information, make it vulnerable to errors on the bare qubits.

However, we have no *a priori* guarantee that these intermediate codes, resulting from our sequence of deformations, will themselves be error-correcting. In light of this, we offer several examples to illustrate the motivation for the aforementioned modifications, which are centered around being able to choose a path so that all of the intermediate codes have high distance. In each of these examples, the extremal codes have distance 3. Thus, we call the circuit fault-tolerant if the intermediate codes it maps between all have distance  $\geq 3$ . For simplicity, we choose  $\overline{G_B}$  according to the original SRA without fixing the transformation to be symmetric, but include ancilla and the full use of invertible transformations on the generator matrices.

**Example 4.1.** With  $m = 0$ , one can fault-tolerantly convert from the  $[[7, 1, 3]]$  Steane code to the perfect  $[[5, 1, 3]]$  code. A quick analysis shows that the conversion circuit given by the SRA uses 17 multiqubit gates. The optimal transformation between these two codes was found via brute force search in [9] and involves 14 multiqubit gates. So while the SRA is not optimal, it comes close, and requires no overhead in data qubits compared to the three extra qubits required in [9]. Note, however, that there must be conversions with large separation between the circuit provided by the SRA and the optimal fault-tolerant circuit, in particular when  $G$  and  $G'$  are locally unitarily equivalent. The generator matrices are presented below, and the conversion occurs by replacing each element of  $G_C$  with its aligned element of  $G'_C$ , from left to right, according to the circuit in Appendix B and supplemented by intermediate error correction.

$$\begin{aligned} G_A = G'_A &= \{-YXXYIZZ\} \\ G_B = G'_B &= \{\} \end{aligned}$$

$$\begin{aligned} G_C &= \{-YYXXZZI, \quad ZZZZIII, \quad -IXZYZZX, \quad -XIYZYZX, \quad -ZYYZIXX\} \\ G'_C &= \{XZZXIII, \quad IXZZXII, \quad XIXZZII, \quad ZXIXZII, \quad IIIIIZI\}. \end{aligned}$$

**Example 4.2.** With  $m = 0$ , one can convert from the (34) permutation of the  $[[7, 1, 3]]$  Steane code to Shor's  $[[9, 1, 3]]$  code fault-tolerantly. However, for the standard choice of generator matrices, no permutation on the ordering of the deformations will suffice. This emphasizes the need for choosing  $U \in GL(\mathbb{F}_2, |G_C|)$  rather than restricting  $U$  to be a permutation matrix. A generator matrix for which the circuit is fault-tolerant is presented below, where  $\overline{G_B}$  is the aforementioned complementary logical operator product from the original SRA. Here, the transformation is once again applied from left to right converting from  $G_C$  to  $G'_C$ , but with the  $G_B \rightarrow \overline{G_B} \rightarrow G'_B$  transformation occurring second, after the first  $G_C$  transformation.

$$\begin{aligned}
G_A = G'_A &= \{ZZIIZZIII, IIIIIIZZ\} \\
G_B &= \{ZZZZIIIIZI\} \\
\overline{G_B} &= \{IIIIIIIXX\} \\
G'_B &= \{ZZIIIIZZI\}
\end{aligned}$$

$$\begin{aligned}
G_C &= \{YIIYYIYII, -ZZYYXXIII, ZIIZZIZII, -XZZXYIYII, -IYZXZYII\} \\
G'_C &= \{-YXYZZIXXX, IZZZZIIIII, -YXXXXXIII, -XYIIIIXXX, IIIZZIIIII\}
\end{aligned}$$

**Example 4.3.** For  $m = 0$ , it was observed in [5] that one cannot use the SRA to fault-tolerantly convert between the  $[[7, 1, 3]]$  code, and the (34) permutation of the  $[[7, 1, 3]]$  code. In fact, one can check more generally that there does not exist a  $U \in GL(\mathbb{F}_2, |G_C|)$  that allows the intermediate codes to be error-correcting. However, one can check that with  $m = 2$ , there does exist such a fault-tolerant circuit, emphasizing the need for ancilla. Moreover, brute force search shows that this is the minimal number of required ancilla. Note that qubit permutations are themselves automatically fault-tolerant by simply relabeling the wires rather than applying a fault-tolerant SWAP gate. The corresponding generator matrix is provided below, with the fault-tolerant conversion again occurring from left to right.

$$\begin{aligned}
G_A = G'_A &= \{XXIIXXIII, ZZZZIIIII, ZZIIZZIII, XXXXIIIII\} \\
G_B = G'_B &= \{\} \\
G_C &= \{XIXIXIXIZ, IIIIIIIZZ, ZIZIZIZIZ, XIXIXIXZZ\} \\
G'_C &= \{XIIXXIXXX, YIIYYIYIX, XIIXXIXII, YIIYYIYXX\}.
\end{aligned}$$

## 5 Distance bounds

We now show that, with low overhead and high probability, the described rSRA will yield a fault-tolerant circuits. More specifically, we show that the intermediate codes preserve the distance of the extremal codes.

**Theorem 5.1.** *Let  $S, S'$  be any two stabilizer codes with parameters  $[[n_1, k, d_1]]$  and  $[[n_2, k, d_2]]$ , respectively. Let  $d = \min\{d_1, d_2\}$  and  $n = \max\{n_1, n_2\}$ . Then, the rSRA will output a fault-tolerant circuit mapping information encoded in  $S$  to information encoded in  $S'$  with probability  $1 - \epsilon$  using  $m = O(d \log \frac{n}{d} + d + \log \frac{1}{\epsilon})$  ancilla qubits.*

*Proof.* Consider a particular error  $e : |e| < d$ . There are four different types of errors to consider.

- (1)  $e \in S \cap S'$ : In this case,  $e \in \text{Span}(G_A)$ , and so remains passively corrected throughout the transformation.
- (2)  $e \in S \setminus \mathcal{N}(S')$ : In this case, we can decompose  $e = g_A + g_B + g_C$  where  $g_A \in \text{Span}(G_A)$ ,  $g_B \in \text{Span}(G_B)$ , and  $g_C \in \text{Span}(G_C)$ . Furthermore,  $g_C \neq 0$ , or else  $e$  would be a logical operator of weight  $< d$  for  $S'$ . Thus,  $e$  must be detected by  $G'_C$ , and so it remains detectable after



step 11. In particular, before the end of step 11,  $e$  must fall out of the intermediate stabilizer group. Suppose this occurs for the first time when transforming between two adjacent codes whose stabilizer groups differ by  $g, g'$ . Then we can write  $e = g + \sum_i a_i g_i$ , and as  $g'$  commutes with all other  $g_i$ , it must be that  $\{e, g'\} = 0$ . Since  $g'$  remains in each intermediate code up through step 11,  $e$  must be detectable throughout.

- (3)  $e \in S' \setminus \mathcal{N}(S)$ : This error is just an error of type (2) when performing the opposite transformation from  $S'$  to  $S$ . By symmetry of the scheme, the set of intermediate codes during this opposite transformation is the same, and so these errors remain detectable by the preceding argument.
- (4)  $e \notin \mathcal{N}(S) \cup \mathcal{N}(S')$ : Let  $G_C^{(0)}, G_C'^{(0)}$  be the bases  $G_C$  and  $G_C'$  we choose after step 6 in the rSRA scheme, and let  $G_C^{(1)}, G_C'^{(1)}$  be the bases we choose after step 8. Note that the syndrome map for  $G_C^{(1)}$  can then be expressed as

$$\text{Syn}_{G_C^{(1)}}(e) = U(V \cdot \text{Syn}_{G_B}(e) + \text{Syn}_{G_C^{(0)}}(e)).$$

In this case it must be that

$$(\text{Syn}_{G_A}(e) | \text{Syn}_{G_B}(e) | \text{Syn}_{G_C^{(0)}}(e))^T \neq 0$$

and

$$(\text{Syn}_{G_A}(e) | \text{Syn}_{G_B'}(e) | \text{Syn}_{G_C^{(0)}}(e))^T \neq 0.$$

Note that if  $\text{Syn}_{G_A}(e) \neq 0$ , then  $e$  is always detectable since each intermediate code includes the check operators from  $G_A$ . Thus, we only need to consider the case where  $\text{Syn}_{G_A}(e) = 0$ , and so we can assume that  $(\text{Syn}_{G_B}(e) | \text{Syn}_{G_C^{(0)}}(e))^T \neq 0$  and  $(\text{Syn}_{G_B'}(e) | \text{Syn}_{G_C^{(0)}}(e))^T \neq 0$ .

Let  $P_e$  denote the probability that the error  $e$  is undetectable in some intermediate code over the random choices of  $U, V$ , and  $V'$ . We divide  $P_e$  into three parts. Let  $A_e$  denote the event that  $\text{Syn}_{G_C^{(1)}}(e) = 0$ ,  $B_e$  the event that  $\text{Syn}_{G_C'^{(1)}}(e) = 0$ , and let  $C_e$  denote the event that both  $\text{Syn}_{G_C^{(1)}}(e)$  and  $\text{Syn}_{G_C'^{(1)}}(e)$  are nonzero, yet  $e$  becomes undetectable on some intermediate code during the transformation. Then  $P_e \leq \Pr[A_e] + \Pr[B_e] + \Pr[C_e]$ . We bound  $\Pr[A_e]$ ,  $\Pr[B_e]$ , and  $\Pr[C_e]$  separately.

$\Pr[A_e]$  &  $\Pr[B_e]$ : Note that  $\text{Syn}_{G_C^{(1)}}(e) = U(V \cdot \text{Syn}_{G_B}(e) + \text{Syn}_{G_C^{(0)}}(e))$ . Since  $U \in GL(\mathbb{F}_2, n - k)$ ,  $A_e$  occurs if and only if  $V \cdot \text{Syn}_{G_B}(e) + \text{Syn}_{G_C^{(0)}}(e) = 0$ .

If  $\text{Syn}_{G_B}(e) = 0$ , it must be the case that  $\text{Syn}_{G_C^{(0)}}(e) \neq 0$ , and so  $\text{Syn}_{G_C^{(1)}}(e) \neq 0$ ; otherwise  $\text{Syn}_{G_B}(e) \neq 0$  and  $V \cdot \text{Syn}_{G_B}(e) + \text{Syn}_{G_C^{(0)}}(e)$  is uniformly random over  $\{0, 1\}^{|G_C|}$ . In either case, we have

$$\Pr[A_e] \leq 2^{-|G_C|}.$$

The same argument shows that  $\Pr[B_e] \leq 2^{-|G_C|}$  as well.

$\Pr[C_e]$ : To bound the probability of  $C_e$  occurring, define  $v = V \cdot \text{Syn}_{G_B}(e) + \text{Syn}_{G_C^{(0)}}(e)$  and  $w = V' \cdot \text{Syn}_{G_B'}(e) + \text{Syn}_{G_C^{(0)}}(e)$ . Since  $Uv, (U^{-1})^T w \neq 0$ ,  $e$  will be detectable

during steps 10 and 12, and so  $C_e$  occurs only if  $e$  becomes undetectable during step 11. Specifically, it must be that  $Syn_{G_A}(e) = 0$ ,  $Syn_{\overline{G_B}}(e) = 0$ , and the last 1 in the vector  $Uv$  comes before the first 1 in the vector  $(U^{-1})^T w$ . This is because we are sequentially replacing the check operators of  $G$  with the check operators of  $G'$ , and an error becomes undetectable for some intermediate code only if we produce some zero syndrome during this sequence of substitutions. By Lemma A.1, for two nonzero vectors  $v, w \in \{0, 1\}^{|G_C|}$ , the probability that the last 1 in  $Uv$  comes before the first 1 in  $(U^{-1})^T w$  is bounded by  $(|G_C| - 1) \cdot 2^{-|G_C|}$ .

Summing these three terms, we have  $P_e \leq (|G_C| + 1) \cdot 2^{-|G_C|}$ . A code has distance  $d$  if and only if it detects all Pauli errors of weight less than  $d$ . Taking a union bound, the probability  $P$  that any of the intermediate codes fail to detect any error of weight less than  $d$  is upper bounded by

$$\begin{aligned} P &\leq \sum_{e:|e|<d} P_e \\ &\leq |\{e : |e| < d\}| \cdot (|G_C| + 1) \cdot 2^{-|G_C|} \\ &\leq 4^{n+m} \cdot e^{-D(\frac{d-1}{n+m} \parallel \frac{3}{4})(n+m)} \cdot (|G_C| + 1) \cdot 2^{-|G_C|} \end{aligned}$$

where  $D(\cdot \parallel \cdot)$  is the KL-divergence, by taking a Chernoff Bound. Note that trivially we can assume  $\frac{d-1}{n+m} < \frac{d-1}{n} < \frac{3}{4}$  by the quantum singleton bound. Furthermore, by Lemma A.2,  $|G_C|$  is given by  $\text{rank}(G^T B G')$ , which is at least  $m$ . So the probability of failure can be further upper bounded by

$$P \leq 4^{n+m} \cdot e^{-D(\frac{d-1}{n+m} \parallel \frac{3}{4})(n+m)} \cdot (m + 1) \cdot 2^{-m}.$$

It suffices to choose  $m$  such that the above quantity is upper bounded by  $\epsilon$  in order to achieve a high probability of success. In particular, the case  $\epsilon = 1$  upper bounds the minimum number of ancilla qubits required for a fault-tolerant transformation. By Lemma A.3 we observe that taking

$$m = O(d \log \frac{n}{d} + d + \log \frac{1}{\epsilon})$$

is sufficient for the rSRA scheme to succeed with probability  $1 - \epsilon$ .

□

## 6 Discussion

Theorem 5.1 shows that with high probability, the rSRA will produce a transversal circuit with intermediate codes which have distance *at least* the minimum of the distances of the extremal codes. This contrasts with recent results from [14], where it was shown that pieceable fault-tolerance offers generic code switching between stabilizer codes subject to certain constraints. In particular, their techniques require that the codes are nondegenerate and have some set of native fault-tolerant Clifford gates, but use no data overhead. The rSRA applies to *any* pair of error-correcting stabilizer codes, while using some small amount of overhead.

Practically, on small examples, one finds that often no ancilla qubits are required to find a fault-tolerant circuit. Moreover, the multiqubit gate complexity of the algorithm is exactly  $\sum_{P \in \{\overline{g_i}\} \cup G_B \cup G_C} |P|$ , so that choosing a low weight generating set is ideal for reducing the complexity of the code switching circuit. For this reason, LDPC codes might provide more efficient

code switching circuits, although their fault-tolerance may depend on choosing a high weight set of generators.

This algorithm derives its usefulness from its generality. For specific code switching examples, it is more profitable to optimize the circuit based on the application, and with access to a larger class of manipulations, such as local Clifford gates. Nevertheless, the rSRA provides a limit on the number of ancilla qubits one needs to consider, which makes the brute force enumeration of all possible conversion paths more tractable for small code instances. In particular, we use ancilla prepared in nonorthogonal states to increase the size of  $G_C$ , which is ultimately what is required to find a fault-tolerant circuit with high probability.

One subtlety about the rSRA is that, while it outputs a fault-tolerant circuit switching between two codes with high probability, it is difficult to check that the particular circuit is fault-tolerant. This follows from the difficulty of computing the minimum distance of a generic error-correcting codes, which is an NP-hard problem in general [6]. Indeed, even when restricting to a particular distance, this check remains extremely costly. This poses a barrier to derandomizing the algorithm, which would be one desirable avenue for future improvement.

Another such improvement would be to minimize overhead. One could imagine taking a random local clifford transformation in order to increase the size of  $G_C$ , rather than introducing ancilla. Such a strategy would be interesting since locally equivalent codes have nearly identical properties. If it is true that one can always choose locally equivalent representatives for which the SRA provides a fault-tolerant conversion, this would suggest that all error-protected information in stabilizer codes is, in some sense, “fault-tolerantly equivalent”. This contrasts with the diverse set of equivalence classes of the more rigid locally equivalent codes.

Similarly, the generality of the rSRA provides an aesthetically nice interpretation of error-protected information. It suggests that, with the addition of some minimal overhead, any stabilizer error-protected encoding of information is indeed “fault-tolerantly equivalent” to any other.

## 7 Acknowledgments

The authors would like to thank Fang Zhang, Kevin Sung, Daniel Minahan, and Yaoyun Shi for useful discussions. This research was supported in part by NSF Awards 1216729, 1318070, and 1526928.

## A Technical lemmas

**Lemma A.1.** *Let  $v, w \in \{0, 1\}^n \setminus \{0\}$  and  $U \in_r GL(\mathbb{F}_2, n)$ . Let  $i_0 = \max\{i : (U \cdot v)_i = 1\}$  and  $i_1 = \min\{i : ((U^{-1})^T \cdot w)_i = 1\}$ . Then,*

$$\Pr[i_0 < i_1] \leq (n-1) \cdot 2^{-n}.$$

*Proof.* Let  $\langle \cdot, \cdot \rangle$  be the dot product over  $\mathbb{F}_2$ . Note that  $\langle v, w \rangle = \langle U \cdot v, (U^{-1})^T \cdot w \rangle$ . If  $\langle v, w \rangle = 1$ , then there must be at least one entry where both  $U \cdot v$  and  $(U^{-1})^T \cdot w$  are 1 for whichever  $U$  we choose, and so  $\Pr[i_0 < i_1] = 0$ . Therefore we only need to consider the case in which  $\langle v, w \rangle = 0$ .

Consider the action of  $GL(\mathbb{F}_2, n)$  on  $A$  defined by  $U(v, w) \rightarrow (U \cdot v, (U^{-1})^T \cdot w)$ , where  $A = \{(v, w) | v, w \in \{0, 1\}^n \setminus \{0\}, \langle v, w \rangle = 0\}$ . We show that the action is transitive by showing that for all such pairs  $(v, w)$ , there always exists a  $U$  sending  $(e_1, e_n)$  to  $(v, w)$ , where  $e_1, e_n$  are  $(1, 0, \dots, 0)$  and  $(0, 0, \dots, 1)$ , respectively. Given such a  $(v, w)$ , first extend  $v$  to a basis for  $w^\perp$ , say  $(u_1 = v, u_2, \dots, u_{n-1})$ , and then extend it to the whole space by adding in  $u_n$ . We claim that  $U = (u_1, \dots, u_n)$  is the desired matrix. It is sufficient to show that the last column  $w'$  of  $(U^{-1})^T$  is exactly  $w$ . We have  $U^T w' = e_n$  given that  $U^T (U^{-1})^T = I$ , and that  $U^T w = e_n$  by construction of  $U$ . Then, since  $U$  is invertible,  $w = w'$ .

A uniformly random distribution over invertible  $U$  then induces a uniformly random distribution over  $A$ . The probability that  $i_0 < i_1$  can then be bounded by counting the number of such pairs in  $A$ :

$$\begin{aligned} \Pr[i_0 < i_1] &= \frac{\sum_{i_0=1}^{n-1} |\{v \neq 0 | v_i = 0, \forall i > i_0; v_{i_0} = 1\}| \cdot |\{w \neq 0 | w_i = 0, \forall i \leq i_0\}|}{|A|} \\ &= \frac{\sum_{i_0=1}^n 2^{i_0-1} (2^{n-i_0} - 1)}{(2^n - 1)(2^{n-1} - 1)} \\ &= \frac{(n-2)2^{n-1} + 1}{(2^n - 1)(2^{n-1} - 1)} \\ &\leq (n-1) \cdot 2^{-n} \end{aligned}$$

for all  $n \geq 2$ . Note that  $|A| = 0$  when  $n = 1$ , so  $\Pr[i_0 < i_1] \leq (n-1) \cdot 2^{-n}$  holds for all  $n \geq 0$ .  $\square$

**Lemma A.2.** *Let  $G_A, G_B, G_C$  and  $G'_A, G'_B, G'_C$  be the matrices defined up to step 5 in the rSRA scheme. The commutativity matrix  $H = G_C^T B G'_C$  is invertible, and its dimension is  $|G_C|$ , with  $|G_C| \geq m$ .*

*Proof.* For the two codes  $\hat{S}$  and  $\hat{S}'$ , take arbitrary generator matrices  $G, G'$  and define  $H' = G^T B G'$ . Note that any two choices of generator matrices for the same code differ by an invertible row transformation, so the rank of  $H'$  is invariant under different choices of the generator matrices. In particular, letting  $G = (G_A | G_B | G_C)$ ,  $G' = (G'_A | G'_B | G'_C)$ , we have

$$H' = \begin{bmatrix} 0 & & \\ & 0 & \\ & & H \end{bmatrix}.$$

Note that  $\text{rank}(H) = |G_C|$ , or else there would exist a combination of the rows of  $G_C'^T$  that are orthogonal to all the columns of  $G_C$ . Since all the vectors in  $G_C'$  are already orthogonal to  $G_A$  and

$G_B$  by definition, this cannot happen as no vector in  $G'_C$  lies in  $\mathcal{N}(S)$ . The same argument applies to  $G'_C$  as well. Therefore  $H$  is invertible, with  $\text{rank}(H') = \text{rank}(H) = |G_C|$ , and is independent of the choice of  $G_C$ .

To show that  $|G_C| > m$ , take  $\bar{G}_C = (I^{\otimes n} \otimes Z \otimes I^{\otimes m-1}, \dots, I^{\otimes n+m-1} \otimes Z)$  and  $\bar{G}'_C = (I^{\otimes n} \otimes X \otimes I^{\otimes m-1}, \dots, I^{\otimes n+m-1} \otimes X)$ , each of size  $m$ . By extending them to generator matrices  $\bar{G}$  and  $\bar{G}'$  for  $\hat{S}$  and  $\hat{S}'$  respectively, we get a commutativity matrix  $\bar{H}$  with an invertible submatrix of size  $m \times m$ , namely

$$\bar{G}_C^T B \bar{G}'_C = I_m,$$

and so  $\text{rank}(\bar{H}) = |G_C| \geq m$ .  $\square$

**Lemma A.3.** For  $D(\cdot||\cdot)$  the KL-divergence, let  $P(n, m, d) = 4^{n+m} e^{-D(\frac{d}{n+m}||\frac{3}{4})(n+m)} \cdot (m+1) \cdot 2^{-m}$ . Then  $P < \varepsilon$  for some  $m = O(d \log \frac{n}{d} + d + \log \frac{1}{\varepsilon})$ .

*Proof.* Let  $\alpha = m/n$ . Then  $P(n, m, d) < \varepsilon$  can be rewritten as

$$f(n, m, d) := \log \frac{P(n, m, d)}{\varepsilon} = \log \frac{m+1}{\varepsilon} + n \left( (2+\alpha) \log 2 - (1+\alpha) D \left( \frac{d}{n(1+\alpha)} \parallel \frac{3}{4} \right) \right) < 0.$$

We first compute the dominant term, i.e. the  $\alpha$  such that

$$\begin{aligned} (2+\alpha) \ln 2 - (1+\alpha) D \left( \frac{d}{n(1+\alpha)} \parallel \frac{3}{4} \right) &= 0 \\ \left( 2 - \frac{\alpha}{1+\alpha} \right) \ln 2 &= D \left( \frac{d}{n(1+\alpha)} \parallel \frac{3}{4} \right) \\ \left( 2 - \frac{\alpha}{1+\alpha} \right) \ln 2 &\geq 2 \ln 2 + \frac{d}{n(1+\alpha)} \left( \ln \frac{d}{3n(1+\alpha)} - 1 \right) \\ \alpha n &\leq \frac{d}{\ln 2} \left( \ln \frac{3n(1+\alpha)}{d} + 1 \right) \\ m &\leq \frac{1}{\ln 2} d (\log \frac{n}{d} + (1 + \ln 3)), \end{aligned}$$

where we used convexity of  $D(p||q) - p \ln p$  with respect to  $p$ . Letting  $\tilde{\alpha}$  denote the solution to  $(2+\alpha) \ln 2 - (1+\alpha) D(\frac{d}{n(1+\alpha)}||\frac{3}{4}) = 0$ , we have that  $\tilde{m} := \tilde{\alpha} n = O(d + d \log \frac{n}{d})$ .

We now have that  $f(n, \tilde{m}, d) = \log \frac{\tilde{m}+1}{\varepsilon}$ . Taking the derivative of  $f$  with respect to  $m$ , for all  $\alpha > \tilde{\alpha}$  we have

$$\begin{aligned} \frac{\partial f(n, m, d)}{\partial m} &= \frac{1}{m+1} + \log 2 - D \left( \frac{d}{(n+m)} \parallel \frac{3}{4} \right) - (m+n) \frac{\partial D(\frac{d}{n+m}||\frac{3}{4})}{\partial m} \\ &\leq \frac{1}{m+1} + \log 2 - \frac{2+\tilde{\alpha}}{1+\tilde{\alpha}} \log 2 + \frac{d}{m+n} \left( \log \frac{d}{m+n-d} - \log 3 \right) \\ &\leq \frac{1}{m+1} - \frac{1}{1+\tilde{\alpha}} \log 2 + \frac{d}{n+m} \left( \log \frac{d}{n+m-d} - \log 3 \right) \\ &\leq -\frac{1}{1+\tilde{\alpha}} \ln 2 + 0.1 \end{aligned}$$

for  $m \geq 10$ . For fixed  $n$ ,  $\tilde{\alpha}$  is monotonically increasing as a function of  $d$ . By the quantum singleton bound,  $\frac{d-1}{n} < \frac{1}{2}$ , and  $\tilde{\alpha} < 3$  even in this case. Therefore  $\frac{\partial f(n, m, d)}{\partial m} \leq -0.05$  when  $m \geq 10$ , so taking

$$m = \tilde{m} + 20 \log \frac{\tilde{m}+1}{\varepsilon} + O(1) = O(d \log \frac{n}{d} + d + \log \frac{1}{\varepsilon})$$

suffices to make  $f(n, m, d) < 0$ .  $\square$

## B Fault-tolerant measurement

For completeness, we include a fault-tolerant code switching circuit between adjacent codes, using Shor-style measurement [12]. We assume access to a collection of verified CAT states. Let  $g = P_1 \otimes \dots \otimes P_n$  and  $g' = P'_1 \otimes \dots \otimes P'_n$ , and let  $(i_1, \dots, i_w), (j_1, \dots, j_{w'})$  denote the indices of the supports of  $g$  and  $g'$ , respectively. To make the diagram simpler, suppose that  $i_1 = j_1 = 1, i_2 = j_2 = 2$ , and  $i_w = j_{w'} = n$ . Then the circuit obtained from the SRA to convert from the code including  $g'$  as a stabilizer to the adjacent code with stabilizer  $g$  is given by the following.

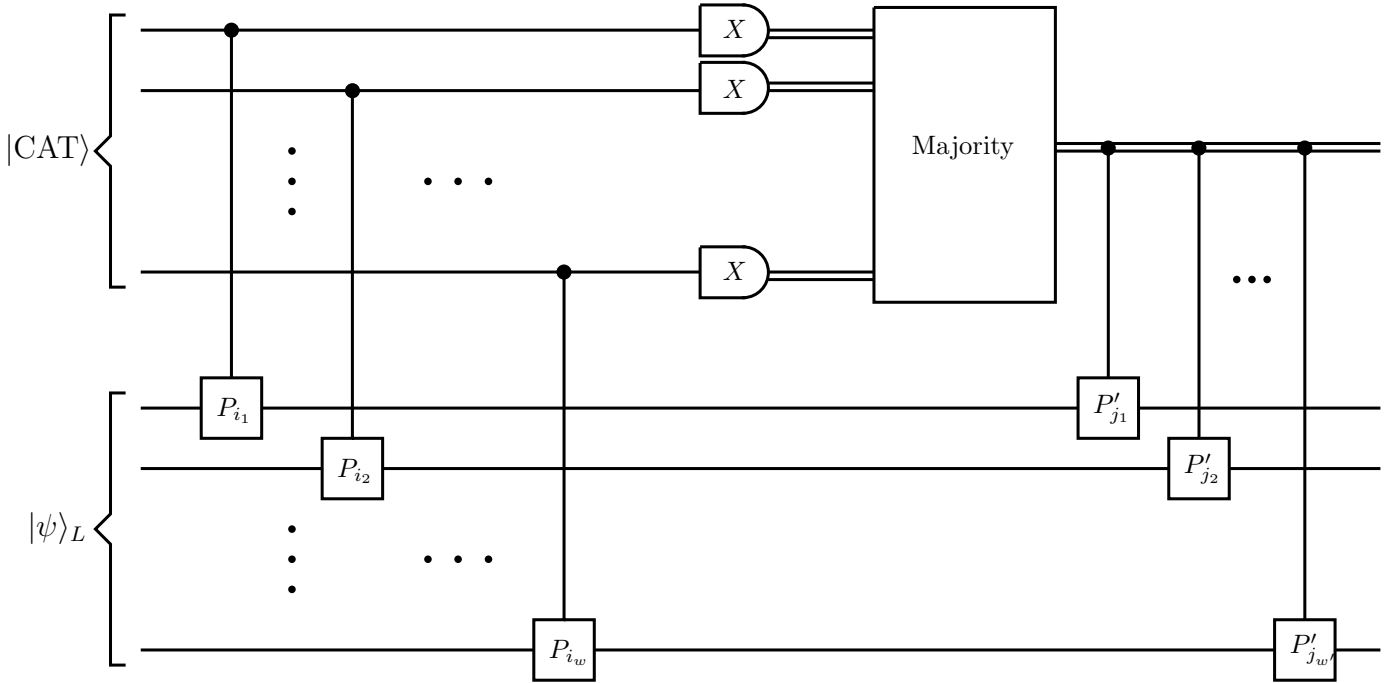

Figure 1: A generic circuit switching between adjacent codes using Shor-style measurement. The input is a logical state in the stabilizer code containing  $g'$ , and the output is that same logical state in the stabilizer code containing  $g$ . The measurement ancilla are fixed to be  $|\text{CAT}\rangle = \frac{1}{\sqrt{2}}(|0\rangle^{\otimes w} + |1\rangle^{\otimes w})$  where  $w$  is the weight of  $g$ .

## References

- [1] P. Aliferis, D. Gottesman, and J. Preskill. Quantum accuracy threshold for concatenated distance-3 codes, 2006. *Quantum Inf. Comput.* 6, 97165.
- [2] J. T. Anderson, G. Duclos-Cianci, and D. Poulin. Fault-tolerant conversion between the steane and reed-muller quantum codes, 2014. *Phys. Rev. Lett.* 113, 080501.
- [3] H. Bombin. Gauge color codes: Optimal transversal gates and gauge fixing in topological stabilizer codes, August 2015. *New J. Phys.* 17 (2015) 083002.
- [4] S. Bravyi and J. Haah. Magic state distillation with low overhead, 2012. *Phys. Rev. A* 86, 052329.
- [5] K. R. Colladay and E. J. Mueller. Rewiring stabilizer codes, July 2017. [arXiv:1707.09403](https://arxiv.org/abs/1707.09403).
- [6] I. Dumer, D. Micciancio, and M. Sudan. Hardness of approximating the minimum distance of a linear code, January 2003. *IEEE Transactions on Information Theory*, 49(1):22-37.
- [7] B. Eastin and E. Knill. Restrictions on transversal encoded quantum gate sets, July 2009. *Phys. Rev. Lett.* 102, 110502.
- [8] A. G. Fowler, S. J. Devitt, and C. Jones. Surface code implementation of block code state distillation, January 2013. *Scientific Reports* 3, 1939.
- [9] C. D. Hill, A. G. Fowler, D. S. Wang, and L. C. Hollenberg. Fault-tolerant quantum error correction code conversion, 2013. *Quantum Inf. Comput.* 13, 439451.
- [10] M. Newman and Y. Shi. Limitations on transversal computation through quantum homomorphic encryption, April 2017. <https://arxiv.org/abs/1704.07798>.
- [11] A. Paetznick and B. W. Reichardt. Universal fault-tolerant quantum computation with only transversal gates and error correction, April 2013. *Phys. Rev. Lett.* 111, 090505 (2013).
- [12] P. W. Shor. Fault-tolerant quantum computation, 1996. 37th Symposium on Foundations of Computing, IEEE Computer Society Press, pp. 56-65.
- [13] T. J. Yoder. Universal fault-tolerant quantum computation with bacon-shor codes, May 2017. [arXiv:1705.01686](https://arxiv.org/abs/1705.01686).
- [14] T. J. Yoder, R. Takagi, and I. L. Chuang. Universal fault-tolerant gates on concatenated stabilizer codes, March 2016. *Phys. Rev. X* 6, 031039 (2016).
- [15] B. Zeng, A. Cross, and I. L. Chuang. Transversality versus universality for additive quantum codes, September 2011. *IEEE Transactions on Information Theory*, Volume: 57, Issue: 9, 6272 - 6284.