

Composable security in relativistic quantum cryptography

V. Vilasini¹, Christopher Portmann^{2,1}, and Lída del Rio¹

¹Institute for Theoretical Physics, ETH Zürich, 8093 Zürich, Switzerland

²Department of Computer Science, ETH Zürich, 8092 Zürich, Switzerland

Relativistic protocols have been proposed to overcome some impossibility results in classical and quantum cryptography. In such a setting, one takes the location of honest players into account, and uses the fact that information cannot travel faster than the speed of light to limit the abilities of dishonest agents. For example, various relativistic bit commitment protocols have been proposed [1, 2]. Although it has been shown that bit commitment is sufficient to construct oblivious transfer [3] and thus multiparty computation, composing specific relativistic protocols in this way is known to be insecure [4, Appendix A]. A composable framework is required to perform such a modular security analysis of construction schemes, but no known frameworks can handle models of computation in Minkowski space.

By instantiating the systems model from the Abstract Cryptography framework [5] with causal boxes [6], we obtain such a composable framework, in which messages are assigned a location in Minkowski space (or superpositions thereof). This allows us to analyze relativistic protocols, and derive novel possibility and impossibility results. We show that (1) coin flipping can be constructed from the primitive channel with delay, (2) biased coin flipping, bit commitment and channel with delay are all impossible without further assumptions, and (3) it is impossible to improve a channel with delay (Fig. 1). This implies in particular non-composability of all proposed relativistic bit commitment protocols, as well as non-composability of (quantum, but non-relativistic) biased coin flipping protocols [7].

- 1. Introduction.** Review of bit commitment protocols, security requirements, composable issues and known attacks. Overview of our results.
- 2. Framework.** Abstract cryptography [5] applied to causal boxes [6]. Ideal resources.
- 3. Results.** Possibility and impossibility results. Proof sketches.
- 4. Discussion.** Relation to other work, limitations of our approach and outlook.

V. Vilasini: vilasini.phys@gmail.com

Christopher Portmann: chportma@ethz.ch

Lída del Rio: lidia@phys.ethz.ch

1 Introduction

What this paper is about. We address construction of resources¹ (like coin flipping and bit commitment) in relativistic quantum cryptography, and security definitions that are robust under composition of resources. We prove constructibility and impossibility results. By “relativistic” we mean basic special relativity: Minkovski space-time with limited signalling speed.

A cryptographic resource: bit commitment. To illustrate the need for a composable analysis of relativistic cryptography, we focus on bit commitment protocols, which has garnered a lot of interest in recent years [1, 2, 9, 10]. Bit commitment is a crucial cryptographic primitive, from which we can construct oblivious transfer [3], multi-party computation [3], coin flipping [11], and zero-knowledge proofs [12].

Definition 1 (Bit commitment, informal definition). A bit commitment protocol (\mathcal{BC}) between two players (say Alice and Bob) involves two phases. In the *commit phase*, Alice commits to a bit $a \in \{0, 1\}$ with Bob by exchanging information with him. In the *open phase*, Alice chooses to open her commitment to Bob and reveals her bit to him through an exchange of information.

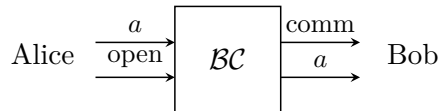

Intuitively speaking, security of bit commitment has two requirements:

- **Hiding:** when Alice is honest, Bob has no information about a before the open phase.
- **Binding:** when Bob is honest, Alice must not be able to change the value of a between the commit and open phases without him detecting her dishonesty.

These requirements can be formalized under different security definitions. Not all models of security of bit commitment are composable: for example the ϵ -weakly binding definition of [10] is not. There, Alice is allowed to commit to a bit without knowing its value, which if used as a subroutine in a coin flipping protocol, would allow dishonest players to perfectly correlate the coin flips from different coins. In this work, we model security such that the constructed bit commitment resource can be securely composed with arbitrary protocols. Let us first overview some known results.

Impossibility of classical bit commitment. In 2001, Canetti and Fischlin showed that composable secure bit commitment without any assumptions is impossible [13]. They proved this for a quantum non-relativistic setting through a classical man-in-the-middle attack (MITM). Consider a cheating Alice simultaneously running two \mathcal{BC} protocols: one with Bob, in which she is the committer, and one with Charlie, in which she is the receiver. She can commit to Charlie’s bit with Bob by simply forwarding their messages to each other during the commit phase. This allows Alice to commit to a bit without even knowing its value, and neither Bob nor Charlie would detect this. Such a situation is dangerous because when a scheme susceptible to a MITM attack is used

¹The Abstract Cryptography framework [5] views cryptography as a resource theory: a protocol constructs a resource (e.g. a system that produces a random coin flip) from some other resource (e.g. a system that allows bit commitment). In the Universal Composability framework [8], resources correspond to ideal functionalities.

in construction of another cryptographic resource, the resulting resource may no longer satisfy the ideal security guarantees. We will see how this affects the construction of coin flipping resources in Section 3.2. Note that this proof does not imply the impossibility of composable secure \mathcal{BC} in either quantum or relativistic settings.

Impossibility of quantum bit commitment. To the best of our knowledge, quantum bit commitment has not been previously analyzed in a composable framework. Using a stand-alone definition with information-theoretic security, Mayers, and Lo and Chau [14–16] independently showed between 1996 and 1997 that no secure quantum bit commitment protocol can be constructed without any assumptions (for example regarding the operations that the parties can perform on their systems) because due to Uhlmann’s theorem, if Bob cannot distinguish between the commitment to a 0 or a 1, then there exists a unitary on Alice’s system allowing her to change the commitment from 0 to 1.

Relativistic protocols One turns to relativistic protocols in the hope of avoiding such attacks by imposing relativistic causal constraints on agents located in Minkovski space—like no-signalling between space-like separated agents and a maximum propagation speed for signals. An example is Kent’s 2012 relativistic \mathcal{BC} protocol [1], which is immune to the Mayers-Lo-Chau attack, since the sender splits into two space-like separated agents who can no longer perform suitable unitaries on their joint systems. Like other relativistic \mathcal{BC} protocols, this protocol implements a timed commitment, which is secure only within a time window given by the time taken by light to travel between remote agents. However, it only satisfies a non-composable, weakly-binding security definition [10]. As we will see, this protocol is susceptible to a man-in-the-middle attack and therefore cannot be securely run as a subroutine in arbitrary protocols.

Composability of relativistic protocols. In relativistic settings, the existing negative results are obtained by analyzing specific examples of protocols and attacks where composition fails [10]. However, without an overall coherent framework for modelling composability in relativistic cryptography, it is impossible to obtain general positive and negative results.

Overview and scope of our results. Here we introduce a framework for modelling composable cryptographic security in the presence of classical, quantum and no-signalling adversaries, and apply it to prove new positive and negative results in relativistic quantum cryptography, as illustrated in Fig. 1. We do this by modelling the abstract information-processing systems of the *abstract cryptography* framework [5] as *causal boxes* [6]. We analyse three cryptographic resources, defined in Section 2: channel with delay (\mathcal{CD}), coin flipping (\mathcal{CF} , including biased variations) and bit commitment (\mathcal{BC}).

Construction results. We show that an unbiased coin flipping resource \mathcal{CF} can be constructed from a channel with delay resource, \mathcal{CD} (Theorem 1). For comparison, Blum’s protocol [11], constructs a weaker biased coin flipping resource from a bit commitment resource [17]. We provide an explicit protocol to construct \mathcal{CF} from \mathcal{CD} and prove its security.

Impossibility results. In Theorem 2 we show that composable secure coin flipping is impossible even in the relativistic case without additional assumptions (e.g. the presence of a shared resource such as \mathcal{CD}). Impossibility of channel with delay follows from the previous result

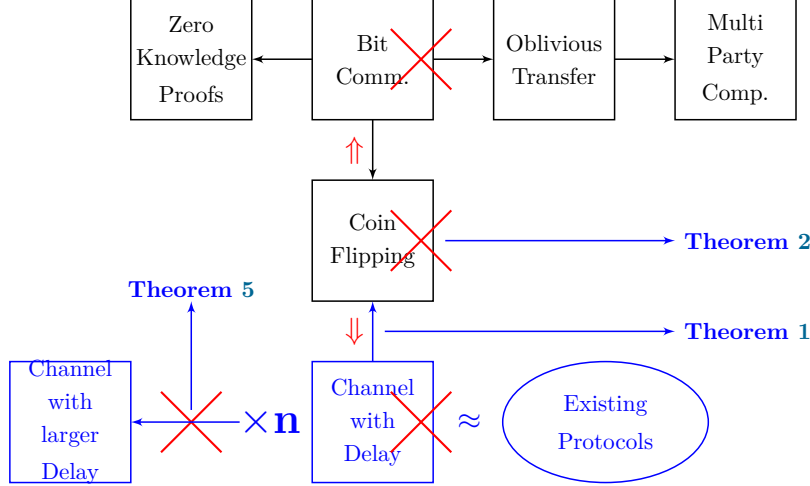

Figure 1: **Summary of our results.** We assume Minkovski space-time with limited speed of signalling. Existing results in black and new results (obtained in this paper) in blue and red. An arrow $\mathcal{R} \rightarrow \mathcal{S}$ stands for “given resource \mathcal{R} , it is possible to construct resource \mathcal{S} through a protocol between distrusting agents that uses unauthenticated communication alone; a cross on a resource means that it is impossible to construct such resource using (unauthenticated) communication alone.” All results are applicable to classical, quantum and relativistic protocols with classical, quantum or non-signalling adversaries. Our framework can also model superpositions of causal orders of message exchanges.

(Corollary 3). This result covers in particular non-composability of Kent’s protocol and of multi-round protocols for arbitrarily long commitments (e.g., [2]). Impossibility of bit commitment follows from Blum’s construction [11, 17] (Corollary 4). We then show that given a number of copies of \mathcal{CD} it is not possible to construct a \mathcal{CD} with a larger commitment window, by using communication alone (Theorem 5). It follows that it is impossible to increase the effective commitment time of a relativistic \mathcal{BC} resource. These impossibility results apply irrespective of whether the protocol is classical, quantum or non-signalling.

Our framework can also be applied to situations where agents exchange a superposition of different numbers of messages in a superposition of orders in time, and provides an operational formalism for studying indefinite causal structures.

2 Framework

2.1 Composable security: the abstract cryptography framework [5]

Let us review the basics of the abstract cryptography framework [5]. The following definitions are adapted from [18] for the case of protocols between two mutually distrusting parties (e.g., bit commitment, coin flipping) and have been simplified for our purposes. We refer the reader to [5] and [18] for more general definitions and further examples. The building blocks of the framework are cryptographic resources, converters (e.g. protocols) and a notion of distance (distinguishability) between resources.

Definition 2 (Cryptographic resource [18]). A resource is an (abstract) system with interfaces $i \in \{A, B\}$, each accessible to a user i (and their trusted agents) providing them with certain controls.

Each resource $\mathcal{R} = (R, R_A, R_B)$, is defined by three functionalities: R when both parties are honest and R_i when party $i \in \{A, B\}$ is dishonest.

A central element of cryptography is the transformation of resources through agent-run protocols: for example, the one-time-pad protocol constructs a secure channel from an authenticated channel. This is formalized through the notion of *converters* which map one resource to another resource.

Definition 3 (Converter [18]). Converters are systems with an inside and an outside interface. The inside interface connects to an interface i of a resource R , and the outside interface becomes the new interface of the constructed resource, $\alpha_i R$.

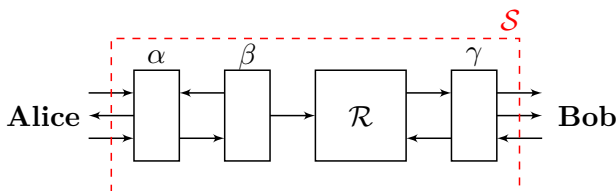

Figure 2: Starting from a resource \mathcal{R} , converters α, β and γ construct a new resource $\mathcal{S} = \alpha_A \beta_A \gamma_B \mathcal{R}$. The sequences of arrows at the interfaces between objects represent (arbitrary) rounds of communication. For simplicity, we may omit the indices, $\mathcal{S} = \alpha \beta \mathcal{R} \gamma$, so that converters to the left of the resource (α, β) are implicitly connected to Alice’s interface, and converters on the right (γ) are connected to Bob’s.

Distinguishing resources. The cryptographic security of a resource is quantified in terms of *distinguishability* from a corresponding ideal resource (Fig. 3). For example, the ideal resource “random bit generator”, \mathcal{S} , would be a black box that generates and outputs a uniformly random bit at a time t which is independent of everything outside the box. A specific practical implementation \mathcal{R} of this functionality could be a quantum protocol: prepare a qubit in state $\frac{1}{\sqrt{2}}(|0\rangle + |1\rangle)$ state, measure it in the Z -basis and output the measurement result at time t . Treated as black boxes, both resources \mathcal{R} and \mathcal{S} output a uniformly random classical bit and cannot be distinguished by an outsider. For more complex resources, we may ask: distinguishability from whose perspective? Here, the traditional notion of an adversary is generalized to an arbitrary *distinguisher* which models not only possible adversarial behaviour but also the whole environment of a cryptographic protocol. In other words, a distinguisher models information-processing steps that could take place before, after or during the protocol under consideration.

Definition 4 (Distinguishing advantage [18]). A *distinguisher* (Figure 3) for two resources \mathcal{R}, \mathcal{S} is a system \mathcal{D} with two interfaces: an inside interface that connects to all the interfaces of a resource, \mathcal{R} or \mathcal{S} , and an outside interface that outputs a single bit: 0 to guess that the resource was \mathcal{R} and 1 to guess that it was \mathcal{S} . If its probability of guessing correctly is $p_{\text{distinguish}}^{\mathcal{D}}(\mathcal{R}, \mathcal{S})$, then the *distinguishing advantage* of \mathcal{D} is defined as $d^{\mathcal{D}}(\mathcal{R}, \mathcal{S}) := 2 p_{\text{distinguish}}^{\mathcal{D}}(\mathcal{R}, \mathcal{S}) - 1$.

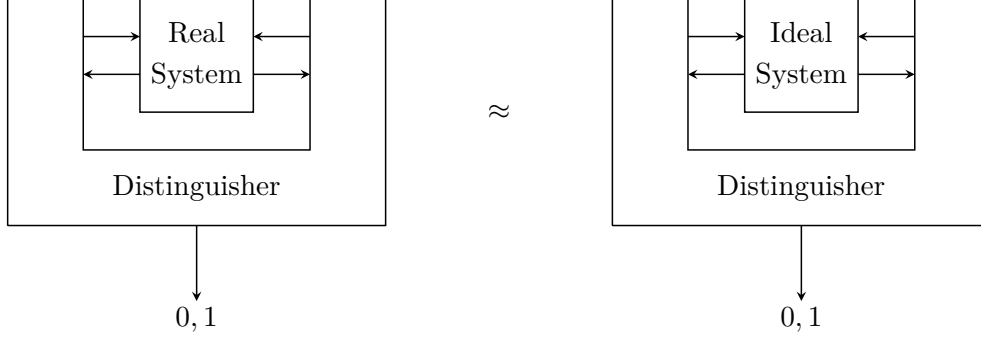

Figure 3: **Security in terms of distinguishers.** Composable security of a real resource is defined in terms of the success probability of a class of distinguishers (for example computationally bounded or unbounded, classical, quantum or non-signalling) in distinguishing the real resource from the ideal functionality. A distinguisher, modelling all the environment of a resource, is given black-box access to either the real or the ideal resources and a complete description of the input-output behaviour of both systems and must guess which one it was interacting with by outputting either a 0 or a 1.

Classes of distinguishers. Changing the power of the distinguisher (e.g., computationally bounded or unbounded, classical, quantum or non-signalling) results in different metrics and different levels of security [18]. For example, classical encryption protocols are only computationally secure. This means that while such a classical resource may be perfectly indistinguishable from an ideal encryption functionality when considering only computationally bounded distinguishers, they could be easily distinguished using computationally unbounded (or quantum) distinguishers.

Remark 1. The distinguishing advantage is a pseudo-metric on the space of resources satisfying the identity, symmetry and triangle inequality properties. It is non-increasing under composition [18], i.e. $d^{\mathcal{D}}(\alpha R, \alpha S) \leq d^{\mathcal{D}}(R, S)$ for any converter α and resources \mathcal{R}, \mathcal{S} .

Cryptographic security of protocols. We want to address questions such as “does a protocol Π construct the ideal resource \mathcal{S} from an initial resource \mathcal{R} ?” A two-player protocol $\Pi = (\Pi_A, \Pi_B)$ is essentially a pair of converters that can be connected to the interfaces of the completely honest functionality R original resource $\mathcal{R} = (R, R_A, R_B)$. Security of the construction must be modelled for three cases: when both players are honest and when either one of them is dishonest. In the honest case, one simply requires that the composition of Alice’s and Bob’s honest protocols with the original resource R , $\Pi_A R \Pi_B$ (the “real system”), is close to indistinguishable from the ideal functionality \mathcal{S} . When Alice is dishonest, the protocol Π_A is removed in the corresponding real system, because we do not know what protocol a dishonest player would follow. On the “real” side we now have $R_A \Pi_B$. On the ideal side, we have \mathcal{S}_A , but $R_A \Pi_B$ and \mathcal{S}_A cannot be compared: they are trivially distinguishable since Alice’s interface of $R_A \Pi_B$ is different from her interface of \mathcal{S}_A . To allow for the comparison and define security against dishonest Alice, we require the existence of a converter σ_A which when connected to Alice’s interface of \mathcal{S}_A makes these two systems close to indistinguishable. Note that connecting this *simulator* σ_A only makes Alice weaker, since any operation performed by the simulator could equivalently be performed by an adversary connected

directly to the interface of the ideal resource. Further, the simulator's behaviour is independent of the internal workings of the ideal functionality S_A . The analysis is analogous for dishonest Bob².

Definition 5 (Composable cryptographic security [18]). A protocol $\Pi = (\Pi_A, \Pi_B)$ constructs $\mathcal{S} = (S, S_A, S_B)$ from $\mathcal{R} = (R, R_A, R_B)$ within a distance ϵ , with respect to a set \mathbb{D} of distinguishers and a set $\mathbb{S} \ni \Pi_A, \Pi_B$ of converters, if the following conditions hold:

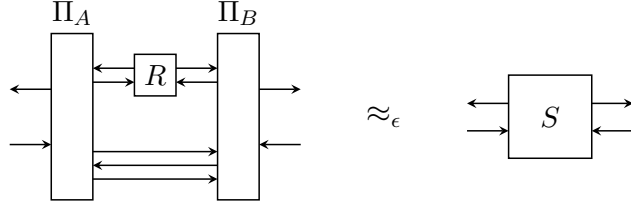

$$\forall \mathcal{D} \in \mathbb{D}, \quad d^{\mathcal{D}}(\Pi_A R \Pi_B, S) \leq \epsilon$$

- (a) When both parties are honest, the functionality constructed by the protocol must be ϵ -indistinguishable from S .

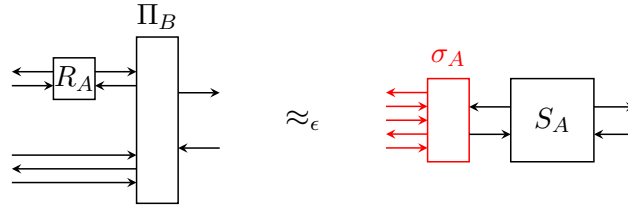

$$\exists \sigma_A \in \mathbb{S}, \quad \forall \mathcal{D} \in \mathbb{D}, \quad d^{\mathcal{D}}(R_A \Pi_B, \sigma_A S_A) \leq \epsilon$$

- (b) When Alice is dishonest and Bob is honest, the resulting system must be ϵ -simulatable by connecting a converter σ_A (called a *simulator*) to Alice's interface of S_A .



$$\exists \sigma_B \in \mathbb{S}, \quad \forall \mathcal{D} \in \mathbb{D}, \quad d^{\mathcal{D}}(\Pi_A R_B, S_B \sigma_B) \leq \epsilon$$

- (c) When Bob is dishonest and Alice is honest, the resulting system must be ϵ -simulatable by connecting a converter σ_B to Bob's interface of S_B .

²The case where both players are dishonest need not be considered as it corresponds to no real protocol.

Remark 2. A **possibility result** for a construction $\mathcal{R} \rightarrow \mathcal{S}$ with parameters $(\varepsilon, \mathbb{S}, \mathbb{D})$ is a statement of the form: there exists a protocol $\Pi = (\Pi_A, \Pi_B)$ that ε -constructs \mathcal{S} from \mathcal{R} , i.e.

$$\exists \Pi_A, \Pi_B, \sigma_A, \sigma_B \in \mathbb{S}, \quad \forall \mathcal{D} \in \mathbb{D}, \quad \text{conditions (a), (b) and (c) hold.}$$

We then say that \mathcal{R} is a **stronger resource** than \mathcal{S} . An **impossibility result** with the same parameters has the form: there exists no protocol $\Pi = (\Pi_A, \Pi_B)$ that ε -constructs \mathcal{S} from \mathcal{R} ,

$$\forall \Pi_A, \Pi_B, \sigma_A, \sigma_B \in \mathbb{S}, \quad \exists \mathcal{D} \in \mathbb{D}, \quad \text{conditions (a), (b) and (c) do not all hold.}$$

The strength of a security proof depends on the range of the class \mathbb{S} of simulators and protocols and the class \mathbb{D} of distinguishers used in the security definition:

For construction results, a strong statement has the form “we can easily construct \mathcal{S} from \mathcal{R} , and we can easily simulate any cheating behaviour, such that even a very powerful distinguisher could not tell apart our construction from the ideal functionality.” Therefore, ideally we would want \mathbb{S} to be restricted to converters that are easy to implement physically, and we want the set of distinguishers \mathbb{D} to be as general as possible.

For impossibility results, a strong statement has the form “we can always easily distinguish any functionality constructed from \mathcal{R} the constructed functionality from \mathcal{S} , even if we allow for very powerful protocols and simulators.” Therefore, we try to make \mathbb{S} to be as general as possible, and we restrict \mathbb{D} to correspond to efficient or otherwise easy to implement distinguishers.

Asymmetric variations. In some settings, we may want to give more power to one of the players. This is the case for blind computation results [19–21], where for example Bob represents a client with limited computational power and Alice a powerful server (which may for example perform arbitrary quantum operations). In other examples, we may want to restrict honest players to use efficient protocols, while allowing the simulators of dishonest behaviour to be arbitrary. In these and other cases, we can adjust the sets for $\Pi_A, \Pi_B, \sigma_A, \sigma_B$ and \mathcal{D} to suit the scenario. For the results in this paper, this will not be necessary.

2.2 Cryptography in relativistic settings: the causal boxes framework [6]

The abstract cryptography framework [5] follows a top-down approach to modelling cryptographic security starting from the highest level of abstraction and proceeding downwards, introducing at each level only the minimum necessary specifications. The composability of abstract systems in the abstract cryptography framework makes it possible to provide a general, composable security definition, which is independent from the models of communication or computation. It can then be instantiated with whatever model is needed — here, causal boxes to model relativistic cryptography.

Causal boxes [6] are a way to model information-processing systems which may interact with each other in arbitrary ways, so long as they respect causality (Fig. 5a). In broad lines, a causal box $\hat{\Phi}$ is a system with input and output wires which may carry quantum or classical information. A concrete example is a physical box containing some optical elements (like beam-splitters) and connected to optical fiber cables: each wire may carry several messages at different times (or even in a superposition of different times). A single instance of a message is modelled as a quantum state in the joint Hilbert space $\mathcal{H} \otimes \mathcal{T}$, where \mathcal{H} is the space of the actual message and \mathcal{T} is a quantum

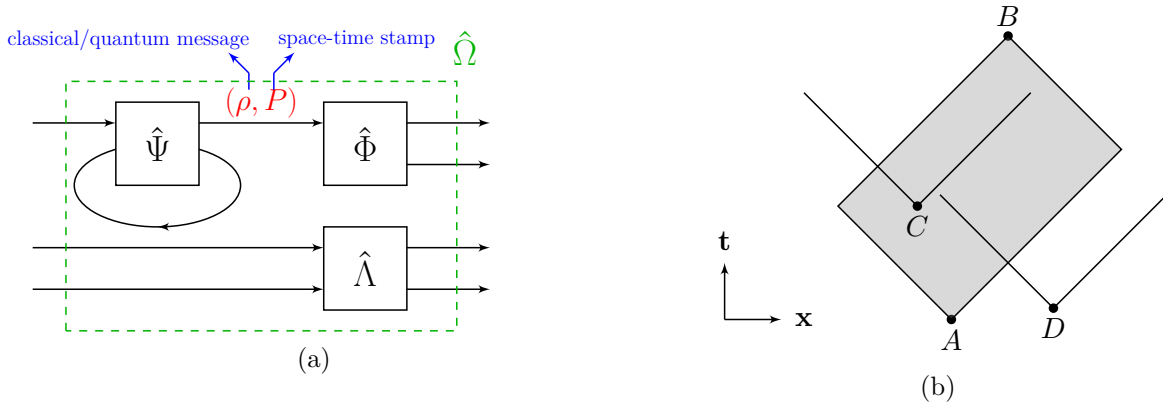

Figure 5: **a. Causal boxes** are information processing systems that respect causality and are closed under composition (serial, parallel or loops). Arbitrary composition of the causal boxes $\hat{\Phi}$, $\hat{\Psi}$ and $\hat{\Lambda}$ is a causal box $\hat{\Omega}$. **b. Minkowski space-time.** The causal diamond of the space-time points A and B (shaded in gray) with $A \prec B$ is denoted by $D(A, B)$. In this figure, point $C \in D(A, B)$ and point D is space-like separated from A since the future light cone of neither of the points completely contains the future light cone of the other.

version of space-time, specifying when and where the message was sent.³ In the simple cases where a message ρ is sent at a well-defined space-time coordinate P , we can simply represent it as a pair (ρ, P) . In this paper we only need to consider such cases.

Causality condition. Causality requires that outputs produced at space-time point $P \in \mathcal{T}$ can depend only on inputs produced in its causal past, $P' \prec P$ (at this stage, \mathcal{T} could be any set of points equipped with any partial order to represent causality). In general, a causal box is a map from the space of the inputs to the space of the outputs that respects this notion of causality.⁴ Composition of causal boxes may be done in series, in parallel or through (feedback) loops (Fig. 5a), and arbitrary composition of causal boxes results in a causal box. For further information, see [6]; for the purposes of this work, the description provided here suffices.

Minkowski space-time. In this paper we apply the formalism of causal boxes to Minkowski space-time \mathcal{T} , where each coordinate corresponds to a vector $P = (\mathbf{x}, t)$ with three dimensions of space and one of time. In special relativity, \mathcal{T} has a natural partial order, “ $P_1 = (\mathbf{x}_1, t_1) \prec P_2 = (\mathbf{x}_2, t_2)$ if light can reach \mathbf{x}_2 from \mathbf{x}_1 in time $t_2 - t_1$.” In this case we say that space-time point P_1 is in the causal past of P_2 . If two points are not ordered, we say that they are space-like separated. The causal diamond of a pair of space-time points, $P_1 \prec P_2$, denoted by $D(P_1, P_2)$ is the intersection of the future light cone of P_1 with the past light cone of P_2 . This represents the maximal space-time region that can be affected by events at P_1 and also affect events at P_2 (Fig. 5b). In the following, we assume that all players involved in a relativistic cryptographic protocol initially agree upon a

³For a finite \mathcal{H} and infinite \mathcal{T} , the joint Hilbert space corresponds to $\mathbb{C}^{|\mathcal{H}|} \otimes l^2(\mathcal{T})$ where $l^2(\mathcal{T})$ is the sequence space with bounded 2-norm. This is the state space of a single input/output message. More generally, wires which can carry messages in a superposition of different numbers and time orderings can be represented by the symmetric Fock space of this message space [6]. (The symmetry comes from the fact that there is no special ordering of the messages other than the space-time ordering, which is already given in the state description itself.)

⁴Technically, this implies that there must necessarily be a finite time gap between an input to a causal box and an output that depends on this input modelling the fact that any causal information processing task takes a strictly non-zero amount of time.

coordinate system to represent all space-time points.

Range of causal boxes. Causal boxes can model not only quantum processes, but also non-signalling systems with quantum and classical inputs (for example, PR-boxes are causal boxes) [6]. This will be useful in security proofs, for example to cover very powerful adversaries, so let us denote by \mathbb{C} the set of all allowed causal boxes in \mathcal{T} .

2.3 Ideal functionalities

We may now define the ideal functionalities of the cryptographic resources relevant to our results.

2.3.1 Channel with Delay (CD)

In special relativity, unless two agents meet at the exact same space-time location to exchange messages, there is necessarily a finite communication delay between them. A *channel with delay* is a cryptographic primitive between two parties based on this physical intuition: Alice sends a message and Bob receives it unaltered with some delay.

Definition 6 (Channel with delay). A channel with delay $CD = (CD, CD_A, CD_B)$ between a sender Alice and a receiver Bob is a resource characterized by:

- a family $\Phi = \{(A_i, B_i)\}_i$ of pairs of space-time locations $(A_i, B_i) \in \mathcal{T} \times \mathcal{T}$, parametrized by some set \mathcal{I} ;
- for every location A_i , a region A_i^D that contains it, satisfying $A_i \in A_i^D \prec B_i$;
- analogously, for every location B_i , a region B_i^D that contains it, satisfying $A_i \prec B_i^D \ni B_i$.

A use $CD^i, i \in \mathcal{I}$ of the channel is defined by the following functionalities.

CD^i : Honest Alice inputs a qubit a into the channel at location A_i , that is the input message is (a, A_i) . Honest Bob receives a at B_i .

CD_A^i : Dishonest Alice inputs (a, A'_i) at any point A'_i in the region A_i^D . Honest Bob receives the message at B_i .

CD_B^i : Honest Alice inputs (a, A_i) at A_i . Dishonest Bob receives the message at any point B'_i in the region B_i^D .

For every $i \in \mathcal{I}$, the *trusted region* of the channel is defined as the set of all space-time points whose causal past contains all of A_i^D and causal future contains all of B_i^D , that is the set $\{P : A_i^D \prec P \prec B_i^D\}$.

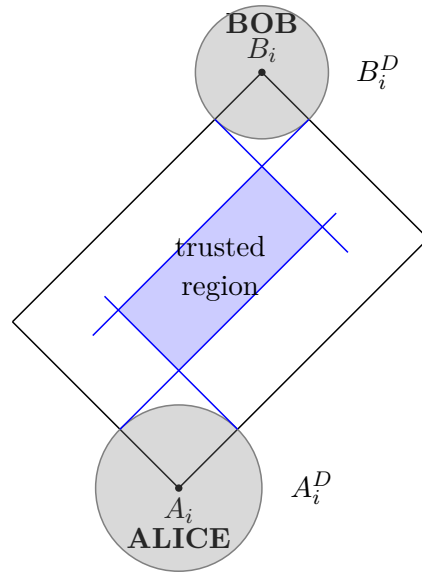

The trusted region of a \mathcal{CD} is a subset of region where both players can be sure that the information in the channel remains secure; as we will see, it is the region where the \mathcal{CD} can be composed to form other resources such as \mathcal{CF} (Section 3.1). For now and in the interest of simplicity, we can model messages sent at a superposition of different locations through Alice’s protocols that use superpositions of different uses \mathcal{CD}^i of a channel.⁵

Relation to relativistic bit commitment protocols. The relativistic protocols existing in the literature, including Kent’s protocol [1] do not claim to implement a bit commitment resource that follows Definition 1, but rather a particular instance of channel with delay. This is due to the following reasons: **1.** The “open” input for Alice and “commit” output for Bob are lacking. **2.** The commitment is not arbitrary as decided by Alice (which is the case of the ideal \mathcal{BC} in definition 1), but are rather a timed commitment, restricted by the time taken by light to travel between the remote agents involved in the protocol. This must be decided in advance by all players. **3.** The protocols assign fixed space-time locations to agents (verified by an agent of the other team). It follows that our results for channel with delay also apply to the existing relativistic protocols for “bit commitment.” Arbitrarily long commitments have been achieved using novel multi-round schemes both in the relativistic case [2] as well as in the quantum case (in the bounded [22] and noisy storage [23] models). However, these schemes are only weakly binding and it follows from our impossibility results ahead that they are not composable secure without additional assumptions.

2.3.2 Coin Flipping (\mathcal{CF})

Suppose that two mutually distrusting parties Alice and Bob, who are located far away from each other, wish to resolve a dispute. They could do this by flipping a fair coin and base their decision on the outcome of the coin flip. However neither party could flip the coin independently for this purpose as the other party can never trust this outcome. To solve this problem, they require a clever cryptographic protocol that allows them to trust the coin flip outcome even though they don’t trust each other. But even before coming up with a protocol, they must first define the functionality they would like the protocol to construct.

They have different ways of doing so depending on how strong they want the constructed resource to be. The strongest resource is a fair and unbiased coin flipping, where both players get a uniformly random bit c , even if they try to cheat. A weaker variation is a biased coin flipping, where a dishonest player can try to bias the bit that the other receives. For other variations see Appendix B.

⁵A more elegant approach is to model a \mathcal{CD} that can handle the superpositions of locations directly. This is possible by using the full formalism of causal boxes (including Fock spaces), and we leave it as future work to avoid introducing too much formalism here. The two alternatives are not equivalent for some purposes (like resource counting). However, for the possibility and impossibility results of this paper, either definition works.

Definition 7 (Coin flipping, \mathcal{CF}). A *fair and unbiased coin flipping* resource, $\mathcal{CF} = \{CF, CF_A, CF_B\}$ is a cryptographic resource between two agents Alice and Bob, defined as:

CF : Alice receives a uniformly random bit c at location P , and Bob receives the same bit at location P' .

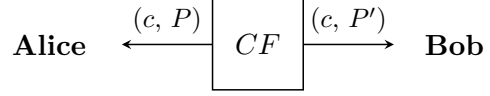

CF_A and CF_B : identical to CF .

By varying the functionalities for dishonest parties, we obtain weaker resources. For example, a *p-biased coin flipping* functionality for dishonest Bob is defined as:

CF_B^b : Dishonest Bob receives his coin flip output c in advance at location P_1 and at location $P_2 \succ P_1$ he may input a bit b conditioned on the value of c . Alice receives a bit c_o^A at location $P \succ P_2$: with probability p she receives $c_o^A = b$, else $c_o^A = c$. Causality requirement: $P_1 \prec P_2 \prec P$.

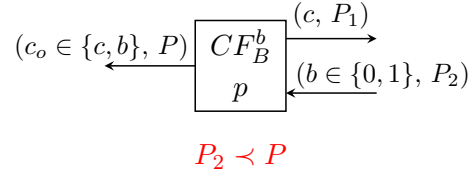

The interface for dishonest Alice can also contain any of these functionalities. We refer to a coin flipping resource as singly or doubly biased accordingly.

Remark 3. The *bias* of a coin flip (where the coin is modelled as a binary random variable C) is defined as $b(C) = 1 - 2P_C(c = 1)$ where $P_C(c = 1)$ is the probability that the outcome of the coin flip equals 1. A p -biased coin flipping resource can produce a maximum bias of p on the honest party's output for any biasing strategy of the dishonest party i.e. $|b(C_o)| \leq p \in [0, 1]$.

The biased functionality could be defined differently depending on the mechanism through which a dishonest player biases the other player's output. An example is the definition used in [17]. All the results presented here also hold for the functionality defined in [17].

3 Results

3.1 Constructibility results

Channel with delay constructs coin flipping. It was shown in [17] that a 1/2-biased coin flipping resource can be perfectly constructed from a bit commitment resource (Definition 1), by using Blum's protocol [11]. Here we show that it is in fact possible to construct an even stronger resource (an unbiased coin flipping) from a channel with delay.

Theorem 1 (Construction $\mathcal{CD} \rightarrow \mathcal{CF}$). Given a classical channel with delay resource \mathcal{CD} with a non-empty trusted region, there exists a classical protocol $\Pi_{\mathcal{CD} \rightarrow \mathcal{CF}} = \{\Pi_A, \Pi_B\}$ that perfectly constructs an unbiased coin flipping resource \mathcal{CF} .

The constructed and ideal resources are indistinguishable for any distinguisher in \mathbb{C} (including quantum and non-signalling distinguishers). Cheating behaviour can be simulated with local operations and classical communication.

The protocol is described in Definition 8, and the security proof is given in Appendix A.

Definition 8 (Protocol $\Pi_{\mathcal{CD} \rightarrow \mathcal{CF}}$). Given a channel with delay $\mathcal{CD} = (CD, CD_A, CD_B)$ with a non empty trusted region, we define the following honest protocol $\Pi_{\mathcal{CD} \rightarrow \mathcal{CF}} = (\Pi_A, \Pi_B)$:

1. Alice picks a uniformly random bit, a and sends it through CD from her space-time location A_i . Bob receives this bit from CD at his location B_i .
2. Bob's agent, Bill meets Alice's agent, Amy at P in the trusted region to pass on Bob's uniformly random bit, b .
3. Alice (or her agent) runs the protocol Π_A to compute $a \oplus b = c$ and outputs this value at some point $P_F^A \succ P$.
4. Bob computes $a \oplus b = c$ using his protocol, Π_B and outputs the result at a point $P_F^B \succ B_i$.

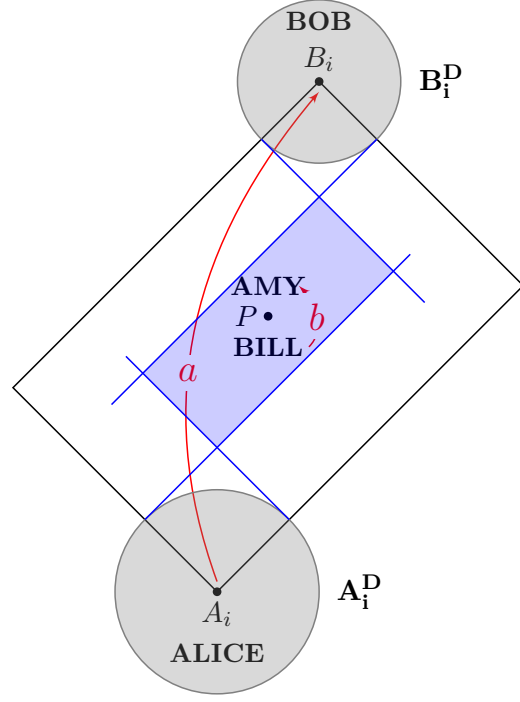

Clearly our protocol $\Pi_{\mathcal{CD} \rightarrow \mathcal{CF}}$ cannot construct a coin flipping resource given a channel with an empty trusted region : in such a case, at least one of the simulators σ_A or σ_B would not exist.

3.2 Impossibility results

Impossibility of coin flipping. In the previous section, we showed that an unbiased coin flipping can be constructed from a suitable channel with delay. Here we show that in the absence of any such shared resource, it is impossible to construct any biased or unbiased coin flipping resource solely through the exchange of messages. The proof idea is sketched in Figure 6 and the full proof can be found in Appendix A. Our proof generalizes the method used in the abstract cryptography framework to prove the analogous result for the non-relativistic case [5].

Theorem 2 (Impossibility of \mathcal{CF}). It is impossible to construct, with $\epsilon < \frac{1}{6}(1-p)$, a p -biased Coin Flipping resource between two mutually distrusting parties solely through the exchange of messages through any relativistic or non-relativistic protocol, be it classical, quantum or non-signalling.

A classical distinguisher suffices to tell apart the ideal functionality from any construction given by a protocol in \mathbb{C} .

Intuition behind Theorem 4: the role of authentication. When no resources are shared by the parties involved in a bit commitment protocol, authentication of messages is no longer guaranteed: it is impossible for the receiver to tell whether a message received is from the original

committer or a third party, as their behaviours are completely symmetric from his/her perspective. Sharing a cryptographic resource breaks the symmetry between the original committer who can access the resource and any other party who can not do so and makes the task possible (Theorem 1). At this point, one may wonder why authentication of messages is a requirement for the composable security of bit commitment. Authentication is closely related to the man in the middle attack (MITM) where a dishonest committer can simply forward messages between the honest receiver and a third party and in turn commit to a bit without knowing its value and without the knowledge of the receiver. When a bit commitment protocol that is susceptible to the MITM attack is used as a subroutine to construct a coin flipping resource using Blum's protocol [11], the constructed coin flipping resource would no longer be secure i.e. it would not satisfy the functionality defined in Definition 7. For example, if Alice and Bob used such a coin flipping resource and Charlie and Danielle used another such resource, dishonest Alice and Charlie (without Bob and Danielle's knowledge) can communicate such that the outcomes of both resources are always perfectly correlated. But the coin flipping functionality requires the outcome of each resource to be independently generated, so an insecure resource of the kind described above would not allow multiple pairs of players to settle disputes independently.

Impossibility of \mathcal{BC} and \mathcal{CD} . Combined with Theorem 1 and Blum's construction [17], this implies impossibility of constructing any channel with delay or any commitment functionality (timed or arbitrarily long) given no initial shared resources.

Corollary 3 (Impossibility of \mathcal{CD}). It is impossible to construct, with $\epsilon < \frac{1}{12}$, a channel with delay resource with non-empty trusted regions between two mutually distrusting parties solely through the exchange of messages through any classical, quantum or relativistic protocol.

A classical distinguisher suffices to tell apart the ideal functionality from any construction given by a protocol in \mathbb{C} .

Proof. Follows directly from the impossibility of \mathcal{CF} in Theorem 2 together with the construction of unbiased \mathcal{CF} from \mathcal{CD} (Theorem 1). □

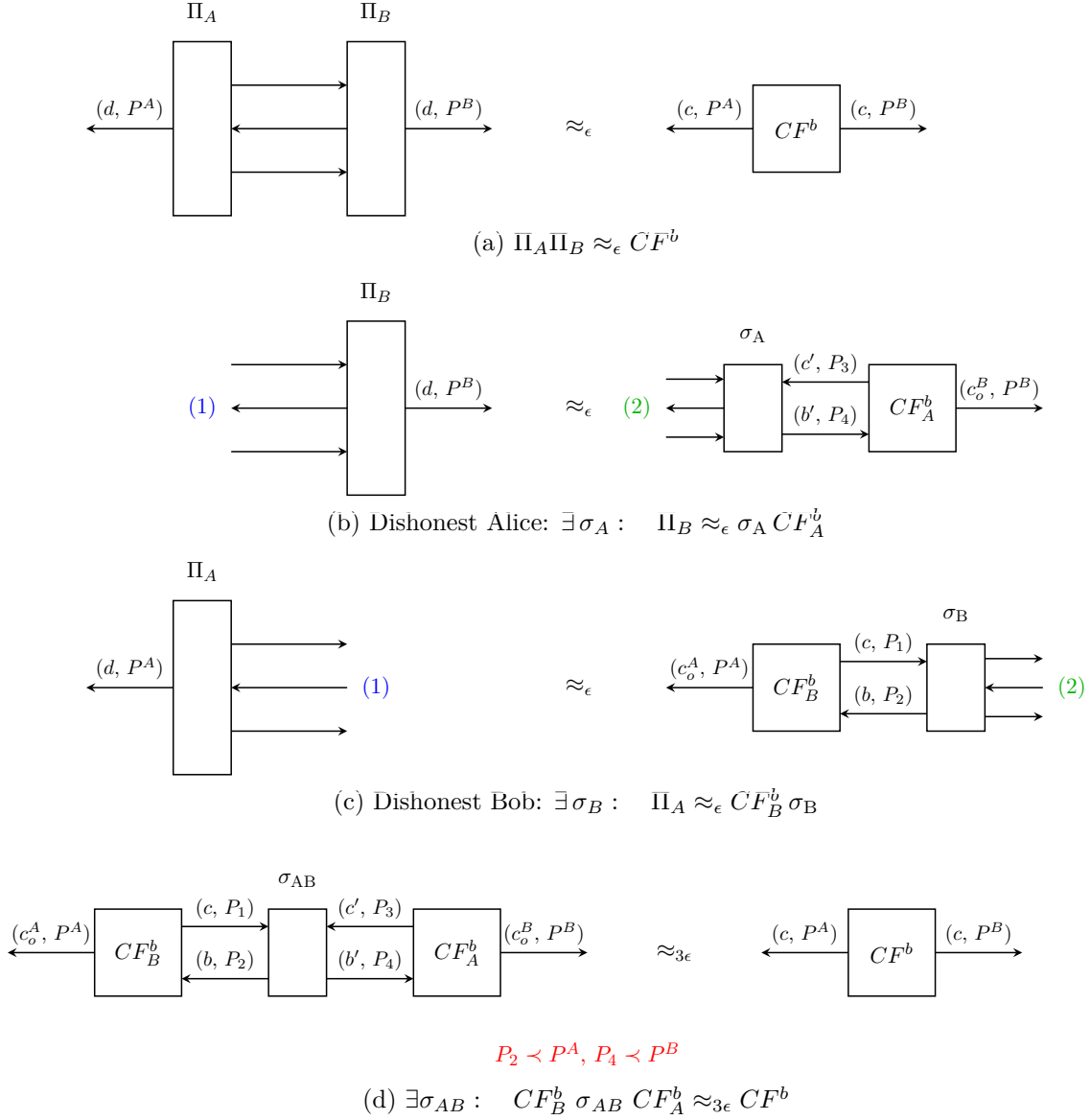

Figure 6: **Impossibility of coin flipping: proof sketch.** For a p -biased Coin Flipping to be ϵ -constructible solely through the exchange of messages, conditions (a)-(c) must be satisfied. The composition (1) of the system on the l.h.s. of (c) (Π_A) with that on the l.h.s. of (b) (Π_B) yields the system on the l.h.s. of (a) ($\Pi_A \Pi_B$) which gives the condition (d) for the corresponding right hand sides (2) with $\sigma_{AB} = \sigma_B \sigma_A$. To prove impossibility, we show in Appendix A that for any causal order of the messages c, c', b and b' , the best possible classical, quantum or non-signalling strategy of σ leads to a distinguishing advantage of at least $3\epsilon = \frac{1}{2}(1-p)$ between $CF_B^b \sigma CF_A^b$ and CF in (d). Note that if the parties had access to a shared resource \mathcal{R} , a condition analogous to (d) could not be obtained by composing (b) and (c), and the same impossibility proof would no longer be applicable.

Remark 4. Note that Corollary 3 is obtained through proof by reduction. If one applies the proof method of Theorem 2 directly to prove the impossibility of \mathcal{CD} (by obtaining an analogue of Figure 6d for \mathcal{CD}), one will see that the proof no longer holds for \mathcal{CD} s for which the dishonest regions A_i^D and B_i^D have a non-zero overlap i.e. it is possible to construct a \mathcal{CD} with overlapping dishonest regions without additional assumptions. Based on this observation and the impossibility result of Corollary 3 which implies the non-composability of existing bit commitment schemes, we conjecture that these schemes construct a \mathcal{CD} functionality with overlapping dishonest regions. However, as seen in the constructibility result of Section 3.1, it is not possible to construct \mathcal{CF} (or any other cryptographic resource) from a \mathcal{CD} with overlapping dishonest regions. For such a resource, there exists no time window within which it can be guaranteed that the information in the channel was safe from both dishonest players.

Corollary 4 (Impossibility of \mathcal{BC}). It is impossible to construct, with $\epsilon < \frac{1}{12}$, a bit commitment resource between two mutually distrusting parties solely through the exchange of messages through any classical, quantum or relativistic protocol. This rules out both arbitrarily long and timed commitments.

A classical distinguisher suffices to tell apart the ideal functionality from any construction given by a protocol in \mathbb{C} .

Proof. Follows directly from the impossibility of \mathcal{CF} in Theorem 2 together with the construction of $\frac{1}{2}$ -biased \mathcal{CF} from \mathcal{BC} using Blum’s protocol [17]. \square

Impossibility of improving a channel with delay. We show that it is not possible to use several channels with delay to construct, in a composable secure way, a better channel with delay: the trusted region of the constructed channel will be smaller than the trusted region of at least one of the individual channels used. In fact, the result is even stronger: the minimum distance between the dishonest regions of the constructed channel will be smaller than the minimum distance between the dishonest regions of at least one of the channels used. This means the maximal space-time region within which the information in the channel is guaranteed to be secure from both dishonest parties cannot be increased even with n copies of a channel. In the context of relativistic bit commitment this implies that it is not possible to increase the time within which the commitment is both hiding and binding even if n timed commitment resources are given. The proof can be found in Appendix A.

Theorem 5 (Impossibility of extending \mathcal{CD}). Given n uses of channels with delay $\mathcal{CD}^1, \dots, \mathcal{CD}^n$ between Alice and Bob, it is impossible to construct with $\epsilon \leq \frac{1}{2}$ a channel \mathcal{CD}' between the two parties with a trusted region that is strictly larger than the trusted region of any of the individual channels used.

This holds for all protocols in \mathbb{C} . The distinguishers given here must be able to reproduce the protocols (for example, for classical honest protocols, classical distinguishers suffice to tell apart the constructed and ideal functionalities).

4 Discussion

The general framework for modelling composable security of relativistic quantum protocols developed here naturally lends itself to the study of novel possibility and impossibility results in relativistic cryptography and could provide key insights into classifying possible and impossible information-processing tasks.

Composability issues raised previously. Composability issues with Kent’s 2012 protocol [1] have been briefly discussed in [10]. Firstly, it must be noted that the security definition used in the discussion of [10] (in their Appendix B) is composable only in a limited sense, in that it guarantees that a bit commitment protocol satisfying the security definition can be composed with itself to give secure string commitment. The definition requires that there exist a classical register containing the value of the committed bit and the joint state of the parties is conditioned on the value in this register. It however doesn’t require that this value be known to the committer. It is hence susceptible to the MITM attack and cannot guarantee security under arbitrary composition with other protocols. Further, it is argued in [10] that as compared to the non-composable weakly binding security definition, this stronger, “composable” definition cannot be satisfied by protocols that do not assume the presence of some external system inaccessible to either party. For example, bit commitment in the bounded and noisy storage models can satisfy this stronger definition because they assume such an environment. However, our results show that the MITM attack makes these protocols non-composable even when we assume presence of such an external system. In fact, it is the presence of such an external, inaccessible system that allows a dishonest committer to outsource her commitment choice. This is irrespective of the reliability or size of the quantum storage available to the adversary. Thus the protocols in the bounded/noisy storage models are also susceptible to MITM.

Indefinite causal structures. The causal boxes formalism [6] can model superpositions of messages exchanged in a superposition of orders in (space-)time (e.g. the quantum switch [24]) by assigning different space-time stamps (or superpositions thereof) to different messages. Combining this with the abstract cryptography framework [5] as done in this paper allows us to model security for cryptographic protocols involving indefinite causal structures and dynamic ordering of messages. While here we focused mostly on known functionalities, the logical next step is to apply our formalism to new resources that make use of quantum superpositions of causal orders.

The framework strictly adheres to a global notion of order: any output can only depend on inputs produced in its causal past and this valid globally for all causal boxes. In contrast to this approach, the process matrix formalism [25, 26] also models indefinite causal structures that violate *causal inequalities* [27] and are not compatible with any global ordering. As far as we know, even for processes that do not admit a causal explanation, no inconsistencies have been found with other physical laws. Thus it is not known whether many of the causal structures modelled by this framework correspond to physically realizable processes [28].

In contrast, all *causal orders* implementable with causal boxes are physically realizable by definition (even if the exact processes and distributions are not, for example in the case of PR-boxes). Causal boxes are a physically motivated framework for understanding indefinite causal structures through their use in operational, information-processing tasks. A comparison of the systems modelled by each framework could provide insights into the properties of physical causal structures and

help identify physical principles that govern causal structures found in nature [29, 30].

Error tolerance. Realistic protocols, like those implemented with quantum preparations and measurements, always come with a small probability of error (for example, in Kent’s protocol as in QKD schemes, this depends on the number of quantum states exchanged between the parties). One could be tempted to think that our impossibility results only hold for ideal resources, and it could actually be possible to build approximate functionalities, like a \mathcal{CD} with a small probability of error. However, our results are robust under error tolerance. To see this, consider a resource \mathcal{CD}^ε that is ε -close to \mathcal{CD} according to the distinguishing distance. By the triangle inequality, if a real protocol implements a resource that is Δ -distinguishable from the ideal \mathcal{CD} , it will be at least $(\Delta - \varepsilon)$ -distinguishable from \mathcal{CD}^ε . For example, for an unbiased \mathcal{CF} , we have $\Delta = \frac{1}{6}$, so it is still impossible to perfectly build any \mathcal{CF} that has an error tolerance smaller than that.

Minimal resources for constructions. Our results show that existing bit commitment protocols [1, 2] cannot construct the target resource \mathcal{BC} from an initial resource \mathcal{R} (here \mathcal{R} was void and only exchange of non-authenticated messages in Minkovski space was taken for granted). Nevertheless, we may still look for alternative initial resource \mathcal{R} that allow the same protocols do construct \mathcal{BC} . For example, taking \mathcal{R} as the assumption (or assurance) that dishonest players cannot interact with third parties would make most these protocols composable secure. To formalize this within the framework, one has to model such assumptions as resources — and explore their functionalities. It would be interesting to explore the minimal resources necessary to make existent protocols secure for construction of \mathcal{BC} . It could be for example that all initial resources that allowed for this have undesirable consequences (like allowing for functionalities widely believed to be impossible).

Alternative space-time. We proved that taking our background physical theory to be special relativity (in the sense of Minkovski space-time with a finite speed of signalling) is not sufficient to make bit commitment possible. This holds when special relativity is combined with classical, quantum and more general non-signalling theories. One possible direction for exploration would be to apply our framework to theories with a space-time \mathcal{T}' that features a different causal order (one example could be general relativity) and test whether composable bit \mathcal{BC} from communication alone is possible in such a theory. Alternatively we could even try to reverse-engineer this problem, and ask which causal properties of a space-time structure \mathcal{T}' could allow for \mathcal{BC} [31].

Acknowledgements

We thank Renato Renner for discussions on security definitions. VV acknowledges support from FQXi for the funding to present this work at Oxford Quantum Networks 2017, the ETH Masters Scholarship from ETH Zurich, Switzerland and the Inlaks Scholarship from Inlaks Shivdasani Foundation, Mumbai, India for funding tuition and living expenses during her Masters. CP acknowledges support from the Zurich Information Security and Privacy Center. LdR acknowledges support from the Swiss National Science Foundation through SNSF project No. 200020_165843 and through the the National Centre of Competence in Research *Quantum Science and Technology* (QSIT), and from the FQXi grant *Physics of the observer*.

APPENDIX

Appendix A Proofs of all results.

Appendix B Extra results and definitions.

A Proofs of all results

A.1 Constructibility results

Theorem 1 (Construction $\mathcal{CD} \rightarrow \mathcal{CF}$). Given a classical channel with delay resource \mathcal{CD} with a non-empty trusted region, there exists a classical protocol $\Pi_{\mathcal{CD} \rightarrow \mathcal{CF}} = \{\Pi_A, \Pi_B\}$ that perfectly constructs an unbiased coin flipping resource \mathcal{CF} .

The constructed and ideal resources are indistinguishable for any distinguisher in \mathbb{C} (including quantum and non-signalling distinguishers). Cheating behaviour can be simulated with local operations and classical communication.

Proof. The protocol $\Pi_{\mathcal{CD} \rightarrow \mathcal{CF}}$ (Definition 8) constructs \mathcal{CF}^{ub} from \mathcal{CD} iff all three conditions of Figure 7 are satisfied. The condition of Figure 7a trivially holds. To see that the conditions in Figures 7c and 7b also hold, consider the following simulators σ_A and σ_B .

σ_A :

1. Receive the input a at space-time location, $A'_i \in A_i^D$ at the outer interface.
2. On receiving input c at P_2 at the inner interface, output $b = a \oplus c$ at the outer interface at P .

For the above construction of σ_A to work, both P_2 and A'_i must lie in the causal past of P . Again, since the channel used in the construction has a non-empty trusted region, $A'_i \prec P$ necessarily holds. Since there are no constraints on the space-time points at which CF_A can produce an output, we can always make it output at a point $P_2 \prec P$.

σ_B :

1. Receive the input b at space-time location, P at the outer interface.
2. On receiving input c at P_1 at the inner interface, output $a = b \oplus c$ at the outer interface at $B'_i \in B_i^D$.

For the above construction of σ_B to work, both P_1 and P must lie in the causal past of B'_i . Since the channel used in the construction has a non-empty trusted region, $P \prec B'_i$ necessarily holds and $P_1 \prec B'_i$ holds since there are no restrictions on the space-time points at which CF_B can produce an output.

It is easy to see that for the above mentioned constructions of the simulators σ_A and σ_B , the real and ideal systems of Figures 7a-7b) are perfectly indistinguishable (for any distinguisher \mathcal{D}) since a , b and c always satisfy the condition that any two of them sum bit-wise to the third. Further, Alice can learn the value of both bits a and b before Bob does but she cannot bias the value of Bob's output, $a \oplus b$ in any way. Neither can she prompt Bob to abort the protocol after learning the value of her bit a , because she has to send a into the channel before he receives b at the point P (by the non empty trusted region condition). Hence the protocol perfectly constructs a fair and unbiased coin flipping resource \mathcal{CF} from a channel with delay \mathcal{CD} . \square

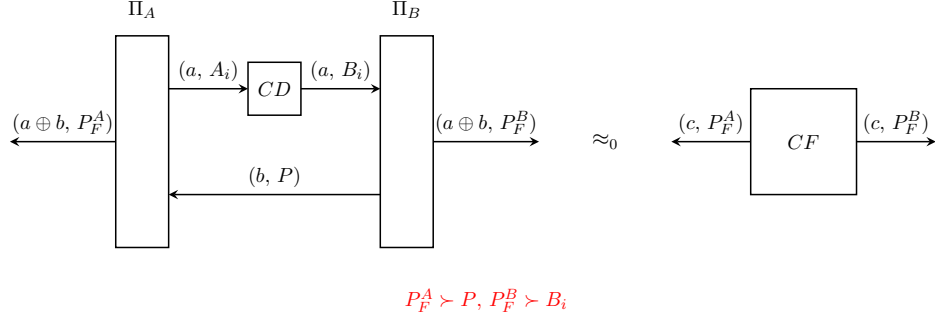

(a) Honest Alice and Bob: $\Pi_A CD \Pi_B \approx_0 CF$

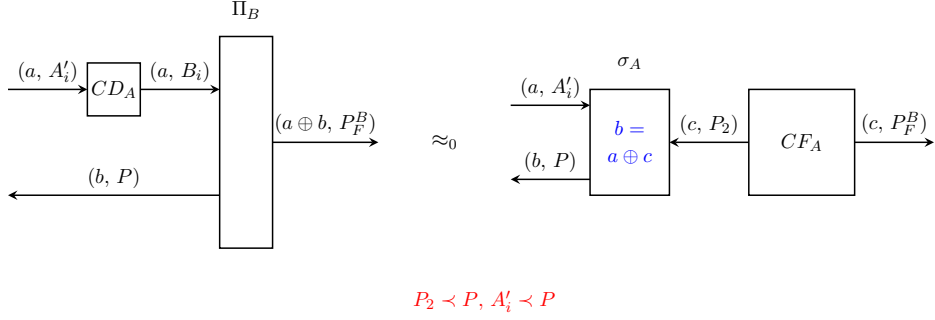

(b) Dishonest Alice: $\exists \sigma_A$ such that $CD_A \Pi_B \approx_0 \sigma_A CF_A$.

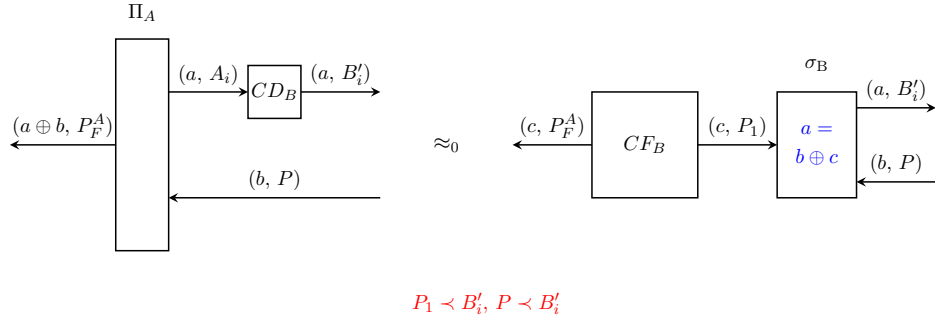

(c) Dishonest Bob: $\exists \sigma_B$ such that $\Pi_A CD_B \approx_0 CF_B \sigma_B$.

Figure 7: Conditions for constructibility of a fair and unbiased coin flipping resource \mathcal{CF} from a channel with delay resource \mathcal{CD} with a non empty trusted region.

A.2 Impossibility results

Theorem 2 (Impossibility of \mathcal{CF}). It is impossible to construct, with $\epsilon < \frac{1}{6}(1-p)$, a p -biased Coin Flipping resource between two mutually distrusting parties solely through the exchange of messages through any relativistic or non-relativistic protocol, be it classical, quantum or non-signalling.

A classical distinguisher suffices to tell apart the ideal functionality from any construction given by a protocol in \mathbb{C} .

Proof. For the construction to be valid, all conditions of Figure 6 must hold. As explained in the figure caption, the first step is to combine the three conditions and use the triangle inequality to obtain Figure 6d, which we reproduce here for commodity:

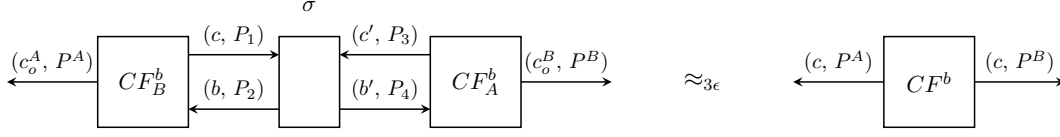

$$\exists \sigma : \quad CF_B^b \sigma CF_A^b \approx_{3\epsilon} CF^b, \quad P_2 \prec P^A, P_4 \prec P^B$$

Next we will show that for any causal order of the messages c , c' , b and b' in Figure 6d, the best possible classical, quantum or non-signalling strategy of σ leads to a distinguishing advantage of at least $3\epsilon = \frac{1}{2}(1-p)$ between $CF_B^b \sigma CF_A^b$ and CF^b . We present here only the optimal strategy — it is a straight-forward if tedious calculation to verify that all other causal orderings and possible input-output correlations in each case do not yield a lower distinguishing advantage.

The simulator's task is to ensure to the best of its capabilities that c_o^A and c_o^B are equal. The casual order of the messages that provide σ with the maximum information to achieve this task is the one depicted by the *directed acyclic graph* (DAG)⁶ in Figure 8, where σ can learn the values of c and c' first and accordingly correlate the values of b and b' which are then input to CF_A^b and CF_B^b respectively. In this case, the best possible strategy that the simulator could adopt would be one where it produces the input-output correlations $b = b' = c$ or $b = b' = c'$ all the time. The probability that c_o^A equals c_o^B for such a strategy (say, $b = b' = c$) is:

$$\begin{aligned} P(c_o^A = c_o^B) &= P(c_o^A = c_o^B | c = c').P(c = c') + P(c_o^A = c_o^B | c \neq c').P(c \neq c') \\ &= \frac{1}{2} + \frac{1}{2}[P(c_o^A = c_o^B | c \neq c', \text{both biased}).P(\text{both biased}) \\ &\quad + P(c_o^A = c_o^B | c \neq c', \text{A biased}).P(\text{A biased}) \\ &\quad + P(c_o^A = c_o^B | c \neq c', \text{B biased}).P(\text{B biased}) \\ &\quad + P(c_o^A = c_o^B | c \neq c', \text{none biased}).P(\text{none biased})] \\ &= \frac{1}{2} + \frac{1}{2}[1.p^2 + 0.p(1-p) + 1.p(1-p) + 0.(1-p)^2] \\ &= \frac{1}{2}(1+p) \end{aligned}$$

An LOCC distinguisher connected to $CF_B^b \sigma CF_A^b$ or CF^b can access the two outputs produced at the outer interfaces of these systems. If the distinguisher guesses $CF_B^b \sigma CF_A^b$ every time the two outputs differ in value and $CF_B^b \sigma CF_A^b$ or CF^b with uniform probability every time the two outputs are equal, the distinguishing advantage would be:

$$d(CF_B^b \sigma CF_A^b, CF^b) = 3\epsilon = P(c_o^A \neq c_o^B) = \frac{1}{2}(1-p) \quad (1)$$

This distinguishing advantage ϵ is equal to zero only when $p = 1$ (totally biased coin) and thus, for a non-trivial p , it is not possible to make the distinguishing advantage ϵ arbitrarily small. \square

⁶DAGs are widely used in the literature to represent causal structures. For classical causal structures (as is the case here, given that the inputs and outputs to σ are classical bits), the nodes (circles) represent random variables and the edges (arrows) represent causal influences.

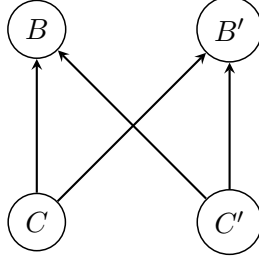

Figure 8: The causal ordering of inputs and outputs of simulator σ (see Figure 6d) that provide it the maximum information about the outputs c_o and c'_o . C, C', B and $B' (\in \{0, 1\})$ represent the random variables of which the corresponding lower case alphabets are specific instances of. In addition, B and B' may causally influence each other, but this does not offer any advantage to σ because the optimal strategy is where both b and b' depend on c (or c').

Remark 5. The proof of Claim 2 is completely general and applies to quantum and non-signalling protocols as well. The apparent “classicality” of the proof is due to the fact that all inputs and outputs are classical bits as per the definition of the functionalities used. However, we only talk about the input-output correlations produced by the simulator σ and not the internal machinery used to produce these correlations, which could be classical, quantum or non-signalling and the impossibility holds for all classical, quantum and non-signalling strategies that σ could adopt to produce these correlations. A particular input-output correlation could be generated through many different strategies but it turns out in this particular case that there exists a simple classical strategy that perfectly produces these correlations (look at the value of c and set $b = b' = c$ all the time), which is why we use correlations produced by σ and strategy adopted by σ quite interchangeably. But one must keep in mind that this in no way restricts the simulator to classical strategies.

Theorem 5 (Impossibility of extending \mathcal{CD}). Given n uses of channels with delay $\mathcal{CD}^1, \dots, \mathcal{CD}^n$ between Alice and Bob, it is impossible to construct with $\epsilon \leq \frac{1}{2}$ a channel \mathcal{CD}' between the two parties with a trusted region that is strictly larger than the trusted region of any of the individual channels used.

This holds for all protocols in \mathbb{C} . The distinguishers given here must be able to reproduce the protocols (for example, for classical honest protocols, classical distinguishers suffice to tell apart the constructed and ideal functionalities).

Proof. To construct a channel \mathcal{CD}' between Alice and Bob given n uses $\mathcal{CD}^1 \dots \mathcal{CD}^n$ of channels between Alice and Bob, the conditions given in Figure 9 must be satisfied such that ϵ is a small, non-negative number \forall distinguishers $\mathcal{D} \in \mathbb{D}$. We make no assumptions regarding the order of the space-time points(/region) $P_I, P_1 \dots P_n, Q_1 \dots Q_n, R$ and P_F in Figure 9 except for the constraints given by the definition of the channel with delay functionalities involved, namely that: $P_I \prec P_F, P_i \prec Q_i \forall i \in \{1, 2, \dots, n\}$. This is because by definition, the output of a channel with delay can only be produced in the causal future of the point where it receives its input. We also do not restrict the channels to transmitting only classical information — each instance of a channel with delay here can carry a single classical or quantum bit.

Let a be the classical/quantum bit to be sent through the resultant channel \mathcal{CD}' . In general, this can be achieved by sending the classical/quantum bits a_1, \dots, a_n through the channels $\mathcal{CD}^1, \dots, \mathcal{CD}^n$ respectively and exchanging any other classical or quantum information which we denote by b

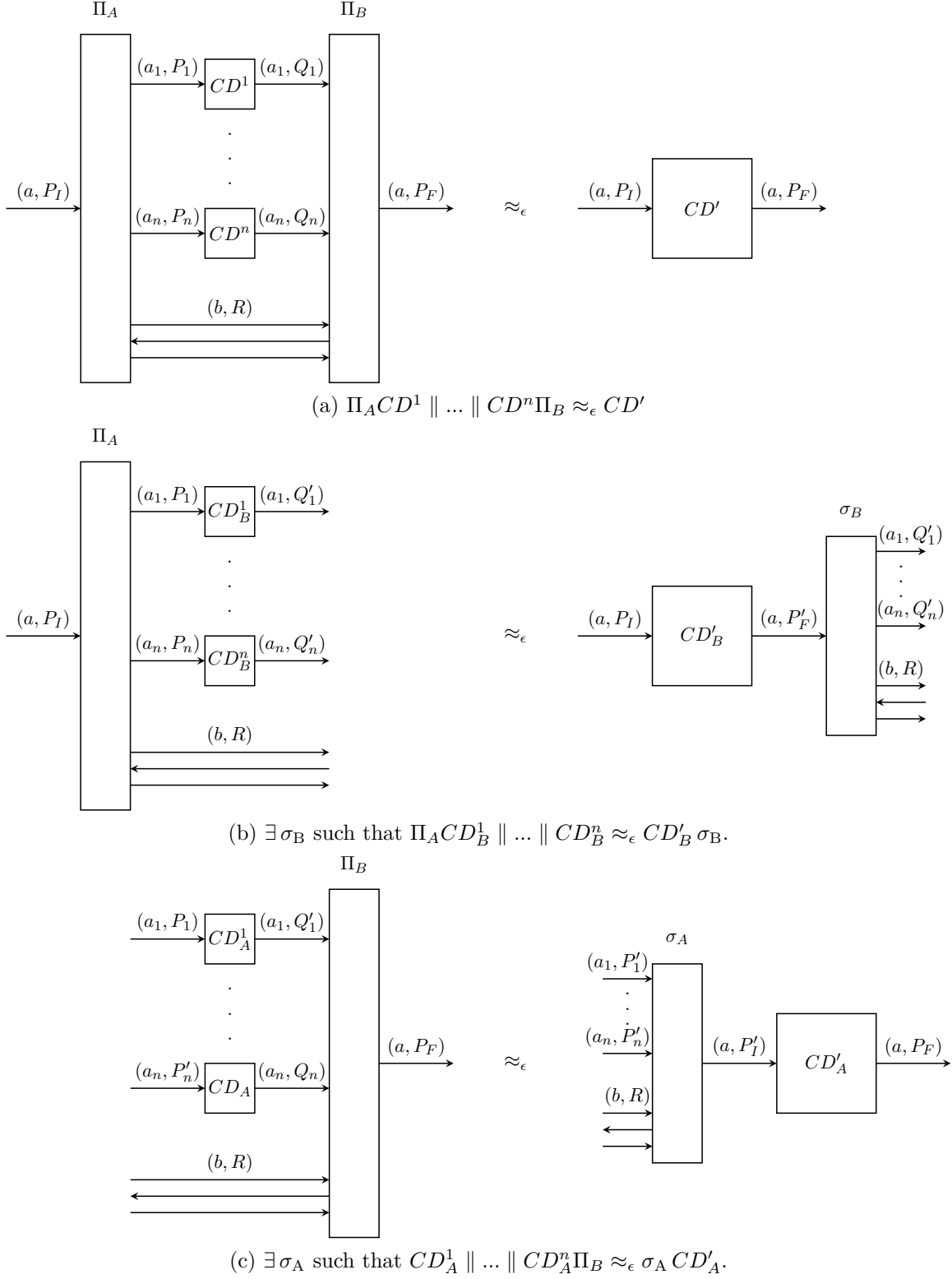

Figure 9: Conditions for building a channel with delay CD' out of n channels with delay CD^1, \dots, CD^n .

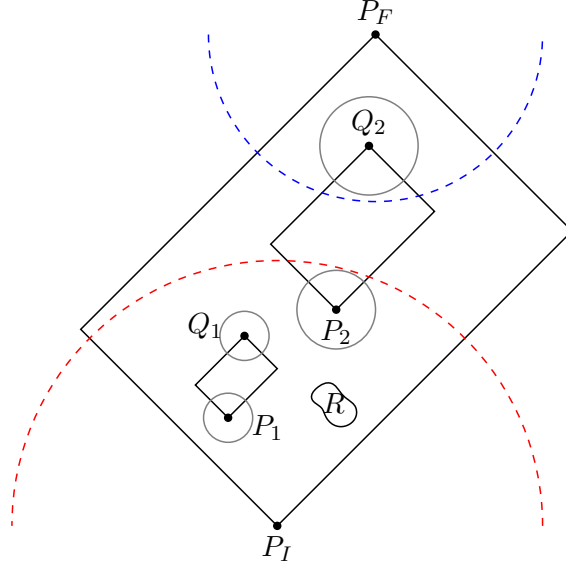

Figure 10: Example of the construction of a channel \mathcal{CD}' from two channels \mathcal{CD}^1 and \mathcal{CD}^2 with circular dishonest regions. For the construction to be possible, the red semi-circle is part of Alice's dishonest region for the constructed channel which must enclose the gray circles around P_1 and P_2 and a part of the region R while the blue semi-circle which represents Bob's dishonest region for \mathcal{CD}' must either completely include the gray circle around Q_1 or that around Q_2 . In both cases the trusted region is reduced (in fact, for this particular example, no trusted region exists for the constructed channel while clearly a non-empty trusted region exists for channel \mathcal{CD}^2).

within the space-time region $R \in D(P, T)$. The information b could consist of any number of classical or quantum bits exchanged between Alice and Bob (Figure 10).

We assume that the bits a_1, \dots, a_n and the information b are all required to uniquely determine a , and no subset of $M = \{a_1, \dots, a_n, b\}$ can give away information about the bit a . If this was not the case and say some subset $S \subset M$ could be used to uniquely determine a , there would be no point sending the remaining information in $M \setminus S$, so we could simply remove those resources from the construction. Let us now analyse the security conditions.

- (a) **When both parties are honest:** It is possible to satisfy the condition of Figure 9a for suitable choice of messages and space-time points such that the honest delay of the constructed channel is larger than that of any of the channels used. The problem only arises when the players are dishonest (which in general they could be).
- (b) **When the receiver (Bob) is dishonest:** In the real protocol of Figure 9b, dishonest Bob can now access the outputs of the channels \mathcal{CD}_B^i at the dishonest locations Q'_i respectively. On the ideal side, the simulator σ_B can access the output a of the ideal functionality \mathcal{CD}'_B possibly at $P'_F \prec P_F$. Let b_{sent} be the set of all messages in b sent by Alice (to Bob) and b_{rec} to be the set of all messages received by Alice (from Bob) such that $b_{sent} \cup b_{rec} = b$ and let R_{sent} and R_{rec} with $R_{sent} \cup R_{rec} = R$ be the corresponding set of space-time points. Now at least one of $a_1, \dots, a_n, b_{sent}$ must depend on the bit a , if not, none of the messages sent would depend on a and it would not be possible to perfectly recover a given all the messages in M .

Hence, a suitable σ_B could possibly exist if and only if Condition (I) *or* Condition (II) or both hold.

- **Condition (I):** $\exists i \in \{1, \dots, n\}$ such that $P'_F \prec Q'_i$.
- **Condition (II):** $P'_F \prec R_{sent}$.

(c) **When the committer (Alice) is dishonest:** In the real protocol of Figure 9c, dishonest Alice can input a_i to CD_A^i from the corresponding dishonest locations P'_i . On the ideal side, the simulator, σ_A can possibly delay the input a to the ideal functionality CD'_A to the space-time point $P'_I \succ P$. Since all of $M = \{a_1, \dots, a_n, b\}$ are required to perfectly recover a and no strict subset of them will give any information about a , a suitable simulator σ_A exists in Figure 9c if and only if both Conditions (III) *and* (IV) hold⁷.

- **Condition (III):** $P'_i \prec P'_I \quad \forall i \in \{1, \dots, n\}$
- **Condition (IV):** $R_{sent} \prec P'_I$.

From the above analysis, Conditions (III) and (IV) must be satisfied for the existence of an appropriate σ_A and at least one of Conditions (I) and (II) must be satisfied for the existence of an appropriate σ_B . Hence, if Conditions (I), (III) and (IV) or Conditions (II), (III), (IV) could be satisfied simultaneously, the construction would be possible. However, Conditions (II) and (IV) together imply that $P'_F \prec P'_I$ which would result in a constructed channel CD' with no trusted region. Thus we rule out this option and focus on the first option i.e., satisfying Conditions (I), (III) and (IV).

Condition (III) states that $P'_i \prec P'_I \forall i \in \{1, \dots, n\}$. This means that for each i , any possible P'_i at which a dishonest sender can send an input into the channel CD_A^i , there should be a point $P'_I \succ P'_i$ from which a dishonest sender must be allowed to send an input into the constructed channel CD'_A which leads to Condition (V). An example for the special case of circular dishonest regions is illustrated in Figure 10.

- **Condition (V):** Alice's dishonest regions corresponding to each of the channels CD^i must lie entirely within Alice's dishonest region for the constructed resource CD' .

Condition (I) states that $\exists i \in \{1, \dots, n\}$ such that $P'_F \prec Q'_i$ which leads to Condition (VI).

- **Condition (VI):** Bob's dishonest region for at least one of the channels CD^i must be entirely contained within his dishonest region for the channel CD' .

In particular, let this be the case when $i = j$ for some $j \in \{1, \dots, n\}$ i.e. Bob's dishonest region for the channel CD^j lies entirely within his dishonest region for CD' . Alice's dishonest region for this j^{th} channel also lies completely within her dishonest region for CD' by Condition (V). Thus for this particular channel, both Alice's and Bob's dishonest regions lie entirely within their respective dishonest regions for the constructed channel CD' and the shortest distance between Alice's and Bob's dishonest regions for CD' must be less than that of CD^j . As a consequence, the trusted region for the constructed channel must be smaller than the trusted region of the j^{th} channel and the constructed channel *cannot* have a trusted region that is larger than that of every channel used.

⁷Only the space-time points in the region R_{sent} are required to lie in the causal past of the dishonest input point P'_I of CD'_A even though all messages exchanged in R are required to reconstruct a . This is because Sim_A could in principle, internally produce messages to be output at R_{rec} at some point in the joint causal past of P'_I and R_{rec} . It could then use these messages to calculate a to be sent at P'_I and also send a copy of these messages to be output in R_{rec} .

If this is the case, all three Conditions (I), (III) and (IV) can in principle be satisfied and there can exist Simulators σ_A and σ_B such that Π constructs \mathcal{CD}' from $\mathcal{CD}^1, \dots, \mathcal{CD}^n$ for a suitably small ϵ . However, the constructed resource will have a smaller trusted region as compared to at least one of the channels \mathcal{CD}^i used.

In the case that neither of Conditions (I), (III) and (IV) or Conditions (II), (III) and (IV) are satisfied simultaneously, the construction would no longer be secure. This is because either σ_B cannot access the ideal channel's output on time and would at best guess a value a_{guess} for the bit a and generate $a_1, \dots, a_n, b_{sent}$ according to this guess (and possibly the inputs b_{rec}) or σ_A does not receive all inputs $a_1, \dots, a_n, b_{sent}$ on time and can again only guess a value for a to be input into \mathcal{CD}'_A at P'_I .

In Figure 9b, a distinguisher that is given black-box access to the real and ideal systems and a description of the honest protocols could prepare and send a classical/quantum bit⁸ a at P_I through the left interface and the messages in b_{rec} in R_{rec} through the right interface. It could then run the protocol Π_A internally to generate the messages $a'_1, \dots, a'_n, b'_{sent}$ from the bit a and check (at some point in the joint causal future of the relevant points) if $a'_1, \dots, a'_n, b'_{sent}$ and the messages a_1, \dots, a_n, b obtained at the right interface are the same. Note that the encryption scheme has to be deterministic so that Π_B to perfectly decrypt a in the original honest protocol to work. Since the messages a_1, \dots, a_n, b are generated by encrypting Sim_B 's guess a_{guess} of a which is completely independent of the actual value of a , such a distinguisher yields a distinguishing advantage of at least $\epsilon \geq 1/2$.

Similarly, in Figure 9c, the distinguisher could input the messages $\{a_1, \dots, a_n, b_{sent}\}$ at the left interface and receive b_{rec} at the left interface and a at the right interface. It could then run the protocol Π_B to decrypt the messages $\{a_1, \dots, a_n, b\}$ to obtain a classical/quantum bit a' and check if this is equal to a that was obtained at the right interface. Again, by the same argument, this would lead to a distinguishing advantage of at least $\epsilon \geq 1/2$.

Hence the distinguishers required in this impossibility proof are as strong as the protocols used. For example, if the protocol $\Pi = \{\Pi_A, \Pi_B\}$ was classical, the corresponding distinguishers would also be classical. \square

Remark 6. Since for at least one of the channels used (say the j^{th} one), the dishonest regions of both parties is contained within the corresponding dishonest regions of the constructed channel, the minimum distance between the dishonest regions of the constructed channel must be less than the minimum distance between the dishonest regions of the j^{th} channel. This means the maximal space-time region within which the information in the channel is guaranteed to be secure from both dishonest parties cannot be increased even with n copies of a channel. In the context of relativistic bit commitment this implies that it is not possible to increase the time within which the commitment is both hiding and binding even if n timed commitment resources are given.

B Extra results

In Section 2.3.2, the dishonest functionalities of the unbiased resource \mathcal{CF} were varied to define the weaker, p -biased resource \mathcal{CF}^b . Here we define another such variation, the unfair coin flipping resource \mathcal{CF}^{uf} and prove that it is a stronger resource than a p -biased resource. Then, by reduction, Claim 2 implies the impossibility of unfair coin flipping without any assumptions.

⁸If a is classical, the distinguisher can always keep a copy. If a is quantum, it can be reprepared since it was prepared by the distinguisher in the first place who knows the state a that it prepared.

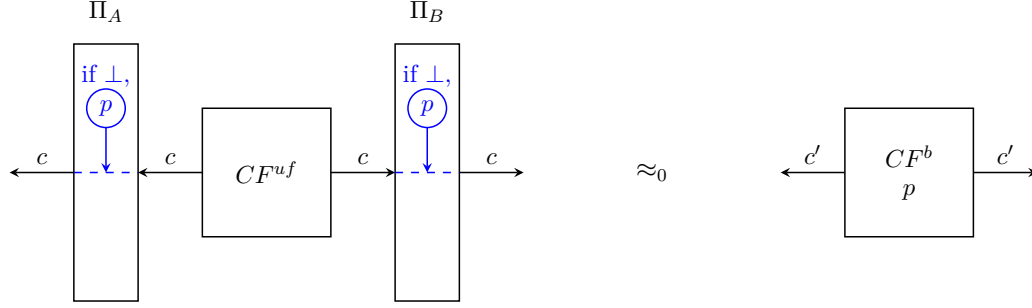

(a) When both parties are honest, the outcomes of the unfair resource CF^{uf} are never equal to \perp and the protocols Π_A and Π_B simply forward the bit c received at the inner interface to their outer interface. This is a perfect construction since $CF^{uf} = CF^b$.

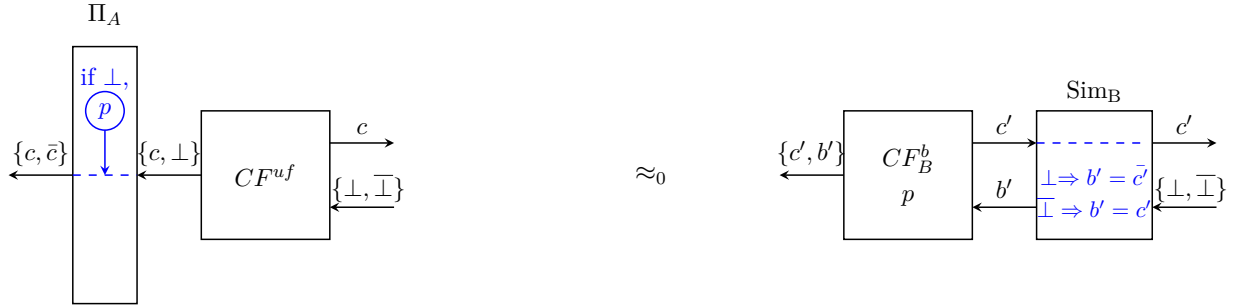

(b) The simulator Sim_B for dishonest Bob simply forwards c' received at its inner interface to its outer interface and sets $b' = c'$ if it receives \perp at the outer interface and $b' = \bar{c}'$ otherwise. Now the protocol Π_A may also receive the abort input and it forwards c with probability $(1 - p)$ and the flipped bit \bar{c} with probability p if it receives \perp from the unfair CF resource and forwards only c otherwise. The construction is perfect because the probability distribution for obtaining the outputs c and \bar{c} from the real system is the same as the probability distribution for obtaining the outputs c' and \bar{c}' from the ideal system and hence the two are perfectly indistinguishable. The argument for dishonest Alice is identical.

Figure 11: Constructibility of a p -biased CF resource from an unfair CF resource. We have dropped the space-time labels corresponding to the messages to avoid unnecessary annotations, but it is easy to see that there exist space-time labels for each message involved such that the above construction is satisfied.

Definition 9 (Unfair coin flipping functionality). An *unfair coin flipping* functionality for dishonest Bob is given by:

CF_B^{ub} : Bob receives uniformly random bit c at location P_1 . At location P_2 he may input a bit $b \in \{\perp, \bar{1}\}$ depending on the value of c received at P_1 . Alice receives message c_0 at a location P : if $b = \perp$, then $c_0^A = \perp$, else $c_0^A = c$. Causality requirement: $P_1 \prec P_2 \prec P$.

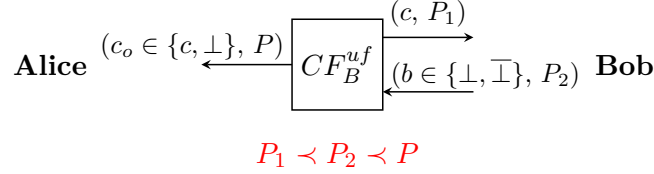

An *unfair and biased coin flipping* functionality for dishonest Bob $CF_B^{uf,b}$ works like a biased coin flipping but with the stricter causality requirement of unfair coin flipping.

Remark 7. Note that a resource that allows dishonest parties to access the coin flip output first but not to prompt an abort or a resource that allows a dishonest party to prompt an abort before learning the output (for example, by simply not participating in the protocol) are also considered to be fair.

Theorem 6. There exists a protocol $\Pi_{\mathcal{CF}^{uf} \rightarrow \mathcal{CF}^b} = \{\Pi'_A, \Pi'_B\}$ that perfectly constructs a p -biased Coin Flipping resource \mathcal{CF}^b from an unfair Coin Flipping resource \mathcal{CF}^{uf} .

Proof. We take the honest protocol $\Pi_{\mathcal{CF}^{uf} \rightarrow \mathcal{CF}^b} = \{\Pi'_A, \Pi'_B\}$:

1. Receive the coin flip outcome from the corresponding interface of the unfair Coin Flipping resource \mathcal{CF}^{uf} at the inner interface.
2. If this outcome has a bit value (say c), output c at the outer interface. If this outcome is an abort (\perp), then output c with probability $(1 - p)$ and $\bar{c} = c \oplus 1$ with probability p at the outer interface.

$\Pi_{\mathcal{CF}^{uf} \rightarrow \mathcal{CF}^b}$ perfectly constructs a p -biased Coin Flipping resource for the following simulators as explained in Figure 11:

1. Receive the output bit c from the biased Coin Flipping ideal functionality on the inner interface and output it at the outer interface.
2. Upon receiving the additional input at the outer interface, forward $b = c$ to the ideal functionality at the inner interface if this input is not an abort ($\bar{1}$) and forward $b = \bar{c}$ to the ideal functionality if the input at the outer interface is an abort (\perp).

□

References

- [1] Kent, A. Unconditionally Secure Bit Commitment by Transmitting Measurement Outcomes. *Physical Review Letters* **109**, 130501 (2012). URL <https://link.aps.org/doi/10.1103/PhysRevLett.109.130501>.
- [2] Lunghi, T. *et al.* Practical Relativistic Bit Commitment. *Physical Review Letters* **115**, 030502 (2015). URL <https://link.aps.org/doi/10.1103/PhysRevLett.115.030502>.
- [3] Unruh, D. Universally Composable Quantum Multi-party Computation. In *Advances in Cryptology – EUROCRYPT 2010*, vol. 6110 of *Lecture Notes in Computer Science*, 486–505 (Springer, 2010). [arXiv:0910.2912](https://arxiv.org/abs/0910.2912).
- [4] Kaniewski, J. *Relativistic quantum cryptography*. Ph.D. thesis, National University of Singapore (2015). [arXiv:1512.00602](https://arxiv.org/abs/1512.00602).
- [5] Maurer, U. & Renner, R. Abstract Cryptography. In Chazelle, B. (ed.) *The Second Symposium on Innovations in Computer Science, ICS 2011*, 1–21 (Tsinghua University Press, 2011). URL <http://conference.itcs.tsinghua.edu.cn/ICS2011/content/papers/14.html>.
- [6] Portmann, C., Matt, C., Maurer, U., Renner, R. & Tackmann, B. Causal Boxes: Quantum Information-Processing Systems Closed under Composition. *IEEE Transactions on Information Theory* 1–1 (2017). URL <http://ieeexplore.ieee.org/document/7867830/>.
- [7] Chailloux, A. & Kerenidis, I. optimal quantum strong coin flipping.
- [8] Canetti, R. Universally composable security: A new paradigm for cryptographic protocols. In *Proceedings of the 42Nd IEEE Symposium on Foundations of Computer Science, FOCS '01*, 136– (IEEE Computer Society, Washington, DC, USA, 2001). URL <http://dl.acm.org/citation.cfm?id=874063.875553>.
- [9] Kent, A. Unconditionally secure bit commitment. *Physical Review Letters* **83**, 1447–1450 (1999). [arXiv:quant-ph/9810068](https://arxiv.org/abs/quant-ph/9810068).
- [10] Kaniewski, J., Tomamichel, M., Hanggi, E. & Wehner, S. Secure Bit Commitment From Relativistic Constraints. *IEEE Transactions on Information Theory* **59**, 4687–4699 (2013). URL <http://ieeexplore.ieee.org/document/6461939/>.
- [11] Blum, M. Coin flipping by telephone a protocol for solving impossible problems. *ACM SIGACT News* **15**, 23–27 (1983). URL <http://portal.acm.org/citation.cfm?doid=1008908.1008911>.
- [12] Kilian, J. Founding cryptography on oblivious transfer. In *Proceedings of the twentieth annual ACM symposium on Theory of computing - STOC '88*, 20–31 (ACM Press, New York, New York, USA, 1988). URL <http://portal.acm.org/citation.cfm?doid=62212.62215>.
- [13] Canetti, R. & Fischlin, M. Universally Composable Commitments. 19–40 (Springer, Berlin, Heidelberg, 2001). URL http://link.springer.com/10.1007/3-540-44647-8_2.
- [14] Mayers, D. Unconditionally Secure Quantum Bit Commitment is Impossible. *Physical Review Letters* **78**, 3414–3417 (1997). URL <https://link.aps.org/doi/10.1103/PhysRevLett.78.3414>.
- [15] Lo, H.-K. & Chau, H. F. Is Quantum Bit Commitment Really Possible? *Physical Review Letters* **78**, 3410–3413 (1997). URL <https://link.aps.org/doi/10.1103/PhysRevLett.78.3410>.
- [16] Lo, H.-K. & Chau, H. Why quantum bit commitment and ideal quantum coin tossing are impossible. *Physica D: Nonlinear Phenomena* **120**, 177–187 (1998). URL <http://linkinghub.elsevier.com/retrieve/pii/S0167278998000530>.

- [17] Demay, G. & Maurer, U. Unfair coin tossing. In *2013 IEEE International Symposium on Information Theory*, 1556–1560 (IEEE, 2013). URL <http://ieeexplore.ieee.org/document/6620488/>.
- [18] Portmann, C. & Renner, R. Cryptographic security of quantum key distribution (2014). URL <http://arxiv.org/abs/1409.3525>. 1409.3525.
- [19] Broadbent, A., Fitzsimons, J. & Kashefi, E. Universal Blind Quantum Computation. In *2009 50th Annual IEEE Symposium on Foundations of Computer Science*, 517–526 (IEEE, 2009). URL <http://ieeexplore.ieee.org/document/5438603/>.
- [20] Dunjko, V., Fitzsimons, J. F., Portmann, C. & Renner, R. Composable Security of Delegated Quantum Computation. 406–425 (Springer, Berlin, Heidelberg, 2014). URL http://link.springer.com/10.1007/978-3-662-45608-8_{ }22.
- [21] Dunjko, V. & Kashefi, E. Blind quantum computing with two almost identical states (2016). URL <http://arxiv.org/abs/1604.01586>. 1604.01586.
- [22] Damgård, I., Fehr, S., Salvail, L. & Schaffner, C. Cryptography in the bounded quantum-storage model. In *IEEE Information Theory Workshop on Theory and Practice in Information-Theoretic Security, 2005.*, 24–27 (IEEE). URL <http://ieeexplore.ieee.org/document/1543950/>.
- [23] Wehner, S., Schaffner, C. & Terhal, B. M. Cryptography from Noisy Storage. *Physical Review Letters* **100**, 220502 (2008). URL <https://link.aps.org/doi/10.1103/PhysRevLett.100.220502>.
- [24] Chiribella, G., D’Ariano, G. M., Perinotti, P. & Valiron, B. Quantum computations without definite causal structure. *Physical Review A* **88**, 022318 (2013). URL <https://link.aps.org/doi/10.1103/PhysRevA.88.022318>.
- [25] Oreshkov, O., Costa, F. & Brukner, Č. Quantum correlations with no causal order. *Nature Communications* **3**, 1092 (2012). URL <http://www.ncbi.nlm.nih.gov/pubmed/23033068><http://www.pubmedcentral.nih.gov/articlerender.fcgi?artid=PMC3493644><http://www.nature.com/doifinder/10.1038/ncomms2076>.
- [26] Brukner, Č. Quantum causality. *Nature Physics* **10**, 259–263 (2014). URL <http://www.nature.com/doifinder/10.1038/nphys2930>.
- [27] Oreshkov, O. & Giarmatzi, C. Causal and causally separable processes. *New Journal of Physics* **18**, 093020 (2016). URL <http://stacks.iop.org/1367-2630/18/i=9/a=093020>.
- [28] Feix, A., Araújo, M. & Brukner, Č. Causally nonseparable processes admitting a causal model. *New Journal of Physics* **18**, 083040 (2016). URL <http://stacks.iop.org/1367-2630/18/i=8/a=083040>.
- [29] Hardy, L. Probability Theories with Dynamic Causal Structure: A New Framework for Quantum Gravity (2005). URL <http://arxiv.org/abs/gr-qc/0509120>. 0509120.
- [30] Hardy, L. Towards quantum gravity: a framework for probabilistic theories with non-fixed causal structure. *Journal of Physics A: Mathematical and Theoretical* **40**, 3081–3099 (2007). URL <http://stacks.iop.org/1751-8121/40/i=12/a=S12?key=crossref.c198165299306c401fad4df60786bbdf>.
- [31] Brassard, G. Is information the key? *Nature Physics* **1**, 2–4 (2005). URL <http://www.nature.com/doifinder/10.1038/nphys134>.