

Energy network: towards an interconnected energy infrastructure for the future

Haoyong Chen^{1*}, Hailin Ge¹, Junzhong Wen¹, Hon-wing Ngan², Ming Qiu¹

Affiliations:

¹Department of Electrical Engineering, South China University of Technology, 510641, Guangzhou, China.

²Asia-Pacific Research Institute of Smart Grid and Renewable Energy, Hong Kong.

*Corresponding author. E-mail: eehychen@scut.edu.cn

Abstract: The fundamental theory of energy networks in different energy forms is established following an in-depth analysis of the nature of energy for comprehensive energy utilization. The definition of an energy network is given. The generalized transfer equations of energy in wires (pipes) are proposed based on the generalized balance equation of energy in space, and the energy and exergy variation laws in the transfer processes are investigated. To establish the equations of energy networks, the Kirchhoff's Law in electric networks is extended to energy networks, which is called the Generalized Kirchhoff's Law. Then the generalized equivalent energy transfer equations with lumped parameters are derived in terms of the characteristic equations of energy transfer in wires (pipes). The equations are finally unified into a complete energy network equation system and its solvability is further discussed. Experiments are carried out on a combined cooling, heating and power (CCHP) system in engineering, the energy network theory proposed in this paper is used to model and analyze this system. By comparing the theoretical results obtained by our modeling approach and the data measured in experiments, the energy equations are validated.

One Sentence Summary: This paper has established the fundamental theory of energy networks formation of which their working principles are validated subsequently.

0 Introduction

The ever increasing concern on energy crisis and pollution of environment has pushed forward the study on smart grid, renewable energy and techniques for enhancing energy efficiency such as the combined cooling, heating and power (CCHP) system [1], and the comprehensive utilization of various forms of energy has also become an important trend. Because the production, transmission and consumption of energy are often accomplished in the form of network, it forms the basis for conceptualizing the formation of the energy network such as one formed by the Britain and the Ireland founded Energy Network Association as the coordinating agency of electricity and gas distribution network [2]. The project "Vision of Future Energy Network" developed by Swiss Federal Institute of Technology has proposed the concept of energy hub and energy interconnector [3,4]. An energy hub is an integrated system of units in which multiple energy carriers can convert, adjust and store, while an energy interconnector is an underground device that enables the integrated transportation of electric energy, chemical energy and thermal energy. The proposal of these conceptions provides a new thought for modeling and analyzing the multi carrier energy network [5,6]. However, the former studies have not explored the unified physical mechanism of different forms of energy in an energy network in theory.

Here we first review the historical development of science concerning with energy transfer. The earliest systematic investigation related with energy transfer is put forward by Jean-Baptiste Joseph Fourier (1768-1830) in his famous masterpiece Analytical Theory of Heat [7] in 1822, in which he set forth the mathematical laws of heat conduction, also known as Fourier's law, stating that the time rate of heat transfer through a material is proportional to the negative gradient in the temperature and to the area, at right angles to that gradient, through which the heat flows. The nature of electricity and its relation to magnetism were not completely understood at the time Fourier published his analytic theory. Georg Simon Ohm (1789-1854) did his study work on resistance in the years 1825 and 1826, and published his results in his famous book The Galvanic Circuit Investigated Mathematically in 1827 [8]. He drew considerable inspiration from Fourier's

theoretical work on heat conduction [9]. However, with the process of industrialization, thermal energy and electric energy were utilized separately and research on heat transfer and electricity transfer were isolated in two different disciplines. A related problem is the transfer of fluid energy, which is often used as a carrier of other types of energy. By the time of Fourier's work, fluid mechanics was a well-developed science especially through the contribution of Daniel Bernoulli (1700-1782). The flow of water in open channels was rigorously studied by civil engineers. Many physiologists also studied water flow through capillary tubes to better understand the flow of blood through narrow vessels. Among them the physician and physiologist Jean Léonard Marie Poiseuille (1799-1869) found that in the absence of gravity, water flux was directly proportional to the pressure difference between the inlet and the outlet and inversely proportional to the length of the capillary [10]. These observations were similar to those made by Ohm in the case of galvanic current.

With the development of distributed energy system and the so-called energy Internet [11-13], the requirement for establishment of unified energy transfer and conversion laws and fundamental theory of energy network considering different energy forms are becoming more and more urgent. In the paper, a generalized approach is envisaged to model the generic nature of various kinds of energy transfer. By consolidating the basic theories of Thermodynamics, Heat Transfer, Electric Network and Fluid Network, the generic attributes of energy are investigated. The generalized equations of energy transfer in line (pipe) are derived based on the energy and its transfer axiom, and the Kirchhoff's laws are generalized for developing the basic equations of the energy network. To verify the above mentioned theories and approaches of energy network, experiments are carried out on a real engineering case of a typical energy network involving a CCHP system and the measured data are analyzed.

1 Fundamentals of an energy network

In engineering practice, energy is often provided to users through networks, such as electric power grids, heat supply networks and gas networks. Because a common feature of these networks is to supply energy, they are uniformly called energy network in this paper. Energy network consists of subnets of different forms of energy, and all these subnets are connected with each other through energy conversion devices. The relationship between the energy network and its subnets is analogous to the relationship between Internet and local area networks (LAN). The schematic diagrams of Internet and an energy network are shown in Fig. 1 and Fig. 2 respectively. Energy can be transferred between the subnets of energy network, just as that information can be exchanged between the local area networks within the Internet. In Internet, different network protocols are often adopted in different LANs, and gateways are needed for protocol conversion and information exchange among different subnets of the Internet. This is also the case in energy network. The subnets of an energy network usually use different forms of energy, and conversion among these different energy forms is necessary, which is accomplished by energy conversion devices such as generators or electric heaters.

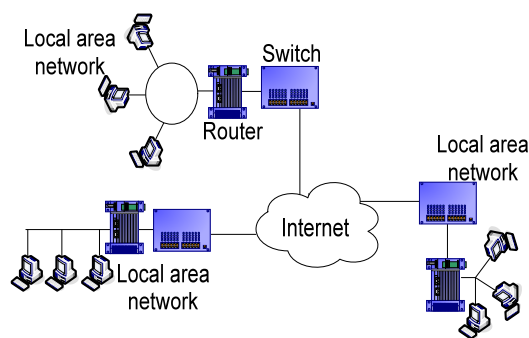

Fig.1 Diagram of Internet

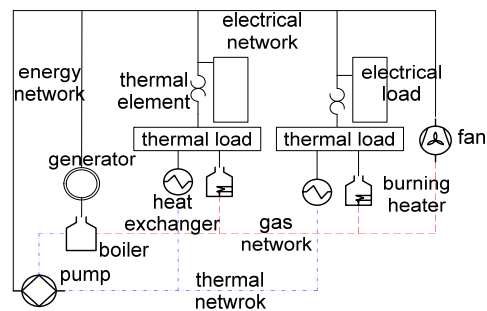

Fig.2 Diagram of energy networks

A basic physical principle in nature is that although electricity as substance cannot be converted to steam or heat, energy can be transferred from electricity to other substances or vice versa. Energy provides a link among different types of physical processes [14,15]. This is the fundamental that the energy network concept and theories rely on. A schematic diagram of chains of physical process is given in [15] and redrawn in Fig. 3 to

explain the underlying physical principles. The turbine converts hydropower energy to mechanical energy; the generator converts mechanical energy to electric energy; the electric heater converts electric energy to thermal energy. The explanation of symbol meanings is left behind.

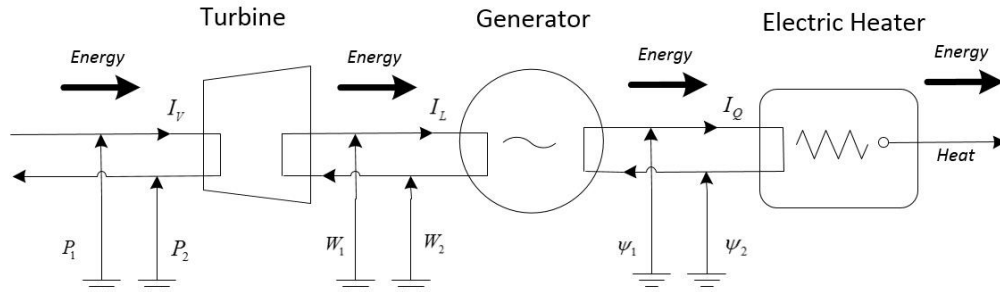

Fig.3 The schematic diagram of chains of physical process

Since energy network is composed of energy conversion devices and transfer lines (pipes) carrying different forms of energy, the unified mathematical representation for various forms of energy is the first step to establish the energy network theory. Several basic definitions and axioms are given here for the development of new theories and approaches.

The State Principle Given any macroscopic system in equilibrium, there exists a group of functional relations among its properties; the number of independent properties in each of these relations for a given system is usually equal to, and in no case greater than, a positive integer n ; the maximum number of independent properties n for a given system depends only on the specification of the system and is found by empirical observation [16]. For a given thermodynamic system, the number of independent thermodynamic properties is equal to the number of reversible related work plus one [17-19].

Several crucial concepts are also introduced in [16], we restate here for convenience:

Homogeneous system. A system is homogeneous if any sub-system has the same set of properties as the system itself, and each of these properties has the same value in each subsystem of the same volume.

Intensive property. A property of a homogeneous system is intensive if, for any given state of the system, the property has the same value in the system itself and in all its subsystems.

Typical intensive properties in physics include temperature, pressure, velocity, electric potential, chemical potential, et al. In the chains of physical process shown in Fig. 3, symbol P_1 , P_2 are pressure, while W_1 , W_2 are angular velocity and ψ_1 , ψ_2 are electric potential. These parameters are intensive properties.

Extensive property. A property of a homogeneous system is extensive if its value, for fixed values of all the intensive properties, is proportional to the mass of the system.

Typical extensive properties in physics include entropy, volume, momentum, electric charge, amount of substance, et al. The extensive quantity is referred to as “substance-like quantity” in [14] and “fluidlike quantity” in [15]. In the chains of physical process shown in Fig 3, symbol I_V is volume flow, while I_L and I_Q are angular momentum flux and electric current respectively. These parameters are extensive properties.

The Energy Axiom The state of a macroscopic system is actually an “energy state” which can be described by the energy state function; The energy of the system is just equal to the integration of the energy state function’s differential between two different states; The differential of the energy state function of any forms can be expressed as the differential of the product of a basic intensive quantity and the corresponding conjugate basic extensive quantity.

The energy state function of a thermodynamic system is defined below, where x_i is the extensive quantity in every unit mass, X_i is the intensive quantity, M is the number of the independent thermodynamic quantities.

$$U(x_1, x_2, \dots, x_M) = \sum_{i=1}^M X_i x_i \quad (1)$$

In physics, energy is a measurement of motion and interaction of matter. There are various forms of matter motion, such as mechanical motion, irregular thermal motion, chemical change, nuclear fission and so on; so energy also has various forms, such as mechanical energy, electromagnetic energy, chemical energy and nuclear energy. Various forms of energy can be converted to each other, but the total energy of an isolated system remains constant. Because energy can be used to measure the changes in the state of the system, the state of the system is a state of energy. The state of energy shall be described by the sum of energy state functions which reflects all the motion patterns of the system. In essence, the existence of the forms of related work is due to the presence of the corresponding energy. Ben Hua et al., who began to think about the nature of “The State Principle” since the mid-1980s, believe that the connotation of “The State Principle” should be “The Energy Axiom” [20,21].

In nature, there is not a reference state that all intensive quantities and extensive quantities are zero. However, the difference between various energy states is the energy that actually can be used. In the research of energy of any physical process, there is no prescript for the initial or terminal energy states. However, in the sense of “the limits of energy that can be really utilized”, the terminal state has special significance, namely the “dead state”, in which the driving force or the difference of intensive quantities disappears. The environment restricts the availability of energy utilization, and the dead state is the state that the system and the surrounding environment reach equilibrium. The fundamental research of “Dead State Thermodynamics” is proposed [22].

Thus, the generalized expression of energy of the system can be expressed as:

$$E = \sum_{i=1}^M X_i x_i - \sum_{i=1}^M X_{i0} x_{i0} \quad (2)$$

where x_{i0} is the dead state value of extensive quantity, X_{i0} is the dead state value of intensive quantity.

In thermodynamics, a concept closely related to energy is *exergy* proposed by Rant [23]. When the surroundings are the reservoir, exergy is the potential of a system to cause a change as it achieves equilibrium with its environment. Exergy is the energy that is available to be used. After the system and surroundings reach equilibrium, the exergy is zero. Energy is never destroyed during a process; it changes from one form to another (the First Law of Thermodynamics). In contrast, exergy accounts for the irreversibility of a process due to increase in entropy (the Second Law of Thermodynamics). Exergy is the work obtained when the system reaches its dead state. Like energy, the definition of exergy also contains various forms of motion, and then the generalized expression of exergy of the system can be expressed as:

$$Ex = \sum_{i=1}^M (X_i - X_{i0}) x_i \quad (3)$$

The Transfer Axiom Any thermodynamic transfer process is the transfer process of the basic extensive quantity driven by the corresponding basic intensive quantity.

The Transfer Axiom is formulated in [22]. However, the similar idea has also been proposed in [14] and [15]. The driving force to promote the flow of extensive quantity, also the cause of the thermodynamic flow, is the difference of the corresponding basic intensive quantity between two different states. Then the transfer law of basic extensive quantity can be generally expressed as:

$$\mathbf{J}_{xi} = K_i \mathbf{F}_i = -K_i \nabla X_i \quad (4)$$

where \mathbf{J}_{xi} is the extensive quantity flow; \mathbf{F}_i is the driving force; K_i is the transfer coefficient of the extensive quantity. The transfer process of the basic extensive quantity is also the transfer process of the corresponding energy and exergy. For instance, the momentum transfer process is the transfer process of the kinetic energy and kinetic exergy at the same time.

On the basis of The Transfer Axiom, **The Energy Transfer Law** can be stated as: The transfer of any form of energy is achieved by the transfer of the basic extensive quantity; similarly, **The Exergy Transfer Law** can be formulated as: The transfer of any form of exergy is achieved by the transfer of the basic extensive quantity. These two transfer laws can respectively be expressed as follows, where \mathbf{J}_{eni} and \mathbf{J}_{exi} are the flow of energy and the flow of exergy respectively, λ_i is the transfer coefficient of energy.

$$\mathbf{J}_{eni} = -X_i K_i \nabla X_i = -\lambda_i \nabla X_i \quad (5)$$

$$\mathbf{J}_{exi} = -\lambda_i \left(1 - \frac{X_{i0}}{X_i}\right) \nabla X_i \quad (6)$$

The equilibrium equations of extensive quantity are prerequisite and foundation for thermodynamic analysis. In the fundamental research of [22], the generalized balance equation of extensive quantity in space is derived. According to The Energy Transfer Law that any form of energy transfer is achieved by the transfer of the basic extensive quantity, then the generalized balance equation of energy in space can be deduced.

In classical field theory and continuum mechanics the Lagrangian specification of the field is a way of looking at fluid motion where the observer follows an individual fluid parcel as it moves through space and time. On the other hand, the Eulerian specification of the flow field is a way of looking at fluid motion that focuses on specific locations in the space through which the fluid flows as time passes. The two specifications are equivalent in mathematics. In the non-equilibrium system, a certain form of extensive quantity within any volume element will change for the following two reasons: part of the certain form of extensive quantity flows in or out the volume element through its boundary; or the certain form of extensive quantity is generated or disappears due to the existence of sources or sinks inside the continuum. Thus, on the basis of the Lagrangian specification, the generalized balance equations of extensive quantity and energy in space can be respectively derived [22]:

$$\rho \frac{dx_i}{dt} = -\nabla \cdot \mathbf{J}_{xi} + g_{xi} \quad (7)$$

$$\rho \frac{X_i dx_i}{dt} = -\nabla \cdot (X_i \mathbf{J}_{xi}) + \mathbf{J}_{xi} \nabla X_i + X_i g_{xi} \quad (8)$$

where ρ is the density of medium; x_i is the extensive quantity in each unit mass of medium; X_i is the intensive quantity; g_{xi} is the source strength of x_i in each unit volume of medium; \mathbf{J}_{xi} is the flow density vector of x_i , which means the amount of x_i that flows through each unit area per unit time.

In equation (7), the expression on the left is the variation of x_i in volume element per unit time. The first expression on the right is the amount of x_i that flows into the volume element through its boundary per unit time.

Similarly, in equation (8), the expression on the left is the variation of energy in volume element per unit time. The first expression on the right is the amount of energy that flows into the volume element through its boundary per unit time; the second one is the amount of exergy that has been consumed under the impetus of intensive quantity gradient; the third one is the amount of energy that emerges as the new extensive quantity is generated.

Kirchhoff's intensive quantity law (KIL) and Kirchhoff's extensive quantity law (KEL)

Kirchhoff's voltage law (KVL) and Kirchhoff's current law (KCL) are the fundamentals of electric network equations [24]. By way of analogy, these laws are also used for the modeling of fluid circuit [25,26]. Kirchhoff's laws summarize the basic rules governing the electric potential distribution and current flow pattern in a network. These basic laws are only determined by the way of circuit connection and do not considered the characteristic of the circuit elements. Electric network is a special case or subnet of an energy network. In order to establish the equations of energy network, this paper proposes extend them to the generalized Kirchhoff's Laws. The potential in electric network is intensive quantity, while the current is extensive quantity. In correspondence with Kirchhoff voltage law (KVL) and Kirchhoff's current law (KCL) in electric network, we propose Kirchhoff's intensive quantity law (KIL) and Kirchhoff's extensive quantity law (KEL) in energy network:

(1) Kirchhoff's intensive quantity law (KIL): in any circuit of an energy network, the sum of intensive quantity difference in each transfer line (pipe) is 0, and this law can be described by $\sum \Delta X = 0$.

As intensive quantity is state parameter, the intensive quantity difference between two nodes in energy network is only related to the state of these two nodes, instead of the path between these two nodes. When starting from one node, moving along a circuit and backing to this node, the intensive quantity difference is 0.

(2) Kirchhoff's extensive quantity law (KEL): in an energy network, the extensive quantity that flows into any node is equal to the extensive quantity that flows out of the node.

With the generalized Kirchhoff's Law, the equations of energy network can be established just like the equations of electric network. Based on the generalized balance equations of extensive quantity and energy in space, the generalized equations of energy transfer in lines (pipes) are further derived. Hence, a key step of the paper is to develop an equivalent model of energy transfer in lines (pipes) through the analysis of the energy transfer mechanism, derive the exergy transfer rule and establish the energy network equations.

2 The generalized equations of energy transfer

2.1 The generalized equations of energy transfer

Essentially, energy transfer is realized through the transfer of related extensive quantity [14,15,22]. Hence, it is necessary to study the transfer laws of extensive quantity in the energy transfer process.

In engineering practice, lines (pipes) for energy transfer often take a cylindrical shape, such as electrical wires, heat-supply pipes and gas pipelines. The section shape of lines (pipes) affects only the flow resistance value of the lines (pipes), and this means that the lines (pipes) with a fixed section shape have a certain flow resistance value per unit length. In this paper, the building block of an energy network is based on the cylindrical transfer lines (pipes) as shown in Fig. 4. The intensive quantity gradient only exists in the axial direction, so energy is transferred in one-dimension.



Fig.4 Cylindrical transfer lines (pipes)

By calculating volume integral for both sides of (7), we get

$$\int_v \left(\rho \frac{dx}{dt} \right) dv = \int_v (-\nabla \cdot \mathbf{J}_x) dv + \int_v g_x dv \quad (9)$$

$$\Rightarrow \frac{dx^*}{dt} = -\oint_A \mathbf{J}_x \cdot d\mathbf{A} + \int_0^L x_g dL$$

where x^* is the total extensive quantity in the cylindrical transfer line (pipe); x_g is a function of the extensive quantity generated in transfer process with regard to line (pipe) length L ; the subscript i in (7) is omitted.

(9) can then be further simplified as:

$$\frac{dx^*}{dt} = \sum JA + x_g = H_A - H_E + \int_0^L x_g dL \quad (10)$$

because of the following reasons:

(a) the extensive quantity x just flows inside the cylindrical transfer line (pipe), and there is no x flowing through the surface of the cylindrical transfer line (pipe);

(b) the direction of area A is its normal direction.

In (10), H is the amount of the extensive quantity of x that flows through the sectional area A per unit time. (10) is the balance equation of extensive quantity in transfer process along the cylindrical transfer line (pipe). Hence, (10) shows that, in unit time, the variation of x in a transfer line (pipe) is equal to the sum of x that flows into the line (pipe) through the sectional area A and x that is generated flowing along the line (pipe).

In the same way, calculating volume integral for both sides of (8) yields:

$$\int_v \rho \frac{XdX}{dt} dv = \int_v -\nabla \cdot (X\vec{J}_x) dv + \int_v \vec{J}_x \nabla X dv + \int_v Xg_x dv \quad (11)$$

$$\Rightarrow \frac{dE}{dt} = -\oint_A (X\vec{J}_x) d\vec{A} + \int_A^E \vec{J}_x \frac{dX}{dL} AdL + \int_A^E Xdx_g$$

E is the total energy in the cylindrical transfer line (pipe). (11) can be further simplified as:

$$\frac{dE}{dt} = \sum XH + \int_A^E HdX + \int_A^E Xdx_g = X_A H_A - X_E H_E + \int_A^E HdX + \int_A^E Xdx_g \quad (12)$$

for the following reasons:

(a) the intensive quantity X just varies along the axial direction, and keeps unchanged along the radial direction;

(b) there is no energy flowing through the surface of the cylindrical transfer line (pipe).

In (12), the expression on the left is the variation of energy in the cylindrical transfer line (pipe) per unit time. The first and second term on the right is the energy that flows into the boundary of the cylindrical transfer line (pipe); the third one is the consumption of exergy in the transfer process; the fourth one is the energy that emerges with the generation of new extensive quantity.

Equations (10) and (12) are the general time-variant equations of transfer process in the cylindrical line (pipe). For the time-invariant equations, terms on the left of equation (10) and equation (12) are both 0, namely the energy and extensive quantity in the transfer line (pipe) remain unchanged. In this situation all extensive quantity generated will flow out, thus

$$dx_g = dH \quad (13)$$

The time-invariant balance equations of energy and extensive quantity in the transfer line (pipe) are given in (14) and (15):

$$H_A - H_E + \int_0^L x_g dL = 0 \quad (14)$$

$$X_A H_A - X_E H_E + \int_A^E H dX + \int_A^E X dH = 0 \quad (15)$$

2.2 Analysis of the energy transfer process

Generally, energy in a system has more than one form and different forms of energy can convert with each other. Thus to describe the energy state of a system, multiple pairs of intensive and extensive quantities are often needed. In this paper, to analyze the transfer law of one energy form, the other energy forms and their corresponding intensive and extensive quantities are assumed to be unchanged in the energy transfer process.

The variation of extensive quantity and intensive quantity in an energy transfer process of the line (pipe) shown in Fig. 4 can be illustrated with Fig. 5. According to (15), the absolute value of the exergy loss in this energy transfer process is area S_{AEGD} , and $\int_A^E H dX = -S_{AEGD}$; the energy increase due to the increase of

extensive quantity in the transfer process is area S_{AENM} , and $\int_A^E X dH = S_{AENM}$. Thus the total energy loss in the transfer process is $S_{AENM} - S_{AEGD}$. We have

$$\begin{aligned} \int_A^E H dX + \int_A^E X dH &= S_{AENM} - S_{AEGD} = S_{ENMF} + S_{AEF} - (S_{AFGD} + S_{AEF}) \\ &= S_{ENOG} - S_{AMOD} = X_E H_E - X_A H_A \end{aligned}$$

which is just the relationship of (15).

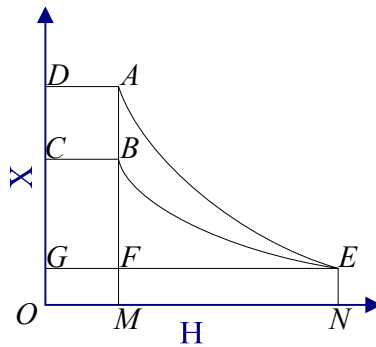

Fig.5 Change curve of extensive quantity - intensive quantity

The energy difference between state A and state E on curve AE represents the energy loss of the system. According to The Energy Axiom, energy is a function of the state parameters X and H , which is irrelevant to the energy transfer process. Hence the energy transfer in the process AE is equal to that of the process ABE. The process AB denotes a transfer process in which the extensive quantity is kept unchanged, such as electric energy transfer; the process BE denotes a transfer process in which the energy is kept unchanged, such as constant temperature heat conduction.

Taking the gas expansion process for instance, if the process is thermostatic, the expansion process is represented by curve BE in Fig. 5. In this process, the total pressure energy of gas remains constant as the heat absorbed is entirely converted to expansion work. If the process is not thermostatic, there is energy exchange between pressure energy and thermal energy in the expansion process, and a part of the heat absorbed will be converted to pressure energy.

2.3 Analysis of the exergy transfer process

The attributes of energy include the quality and amount. The quality of usable energy is termed as exergy. The generalized expressions of energy and energy in differential form have been proposed in [22]:

$$dEn_i = X_i dx_i \quad (17)$$

$$dEx_i = (X_i - X_{i0}) dx_i \quad (18)$$

The total energy of any isolated system remains constant in any variation process. Under the constraint of energy conservation, the sum of the source strength of all kinds of energy in a micro-unit should be equal to 0, which can be formulated as:

$$\sum dEn_i = \sum X_i dx_i = 0 \quad (19)$$

The energy of an isolated system will devalue if the changing process is irreversible. According to the condition of energy conservation, the decrement of total exergy in an isolated system is the loss of the total exergy in the variation process. Thus, the generalized expression of exergy loss in the transfer process can be derived by substituting (19) into (3):

$$dD_{ex} = -\sum dEx_i = \sum X_{i0} dx_i \quad (20)$$

where dD_{ex} is the exergy loss; X_{i0} is the dead state value of intensive quantity; x_i is the extensive quantity. (20) shows that the exergy loss occurs when the dead state value X_{i0} of intensive quantity is not 0 and the corresponding extensive quantity increases in the transfer process.

In the process of AB in Fig. 5, the extensive quantity is kept unchanged while the intensive quantity of the system decreases, and part of the total energy in the system is converted to other forms of energy. From state A to state B, the total energy of the system reduces, but the quality of energy passed to B remains invariant. In the process of BE, the extensive quantity increases while the intensive quantity decreases in the transfer process, and the total energy in the system remains unchanged. According to equation (17), in the transfer process if the dead state value of intensive quantity is not 0, there will be exergy loss (such as the transfer process of pressure energy, chemical energy and thermal energy); otherwise, there will be no exergy loss (such as the transfer process of electric energy). For example, when electric energy passes an ideal transformer, the total energy on the primary and secondary sides is equal. Although the intensive quantity (electric potential) and extensive quantity (electric current) varies, the exergy of electric energy still remains unchanged.

From the above analysis, we can know that there is a cost in the energy transfer process in line (pipe). Either the amount of energy keeps invariant while the amount of exergy decreases, or the amount of energy keeps invariant while the amount of exergy decreases. However, whatever the cost is, as long as the transfer process is irreversible, the loss of exergy exists. Because in reality the device such as ideal transformer does not exist, the energy transfer process is irreversible. Thus the exergy loss is inevitable in any actual energy transfer process. According to (16),

$$\begin{aligned} \int_1^2 H dX + \int_1^2 X dH &= S_{AENM} - S_{AEGD} = S_{ENMF} - S_{AFGD} = S_{ENOG} - S_{AMOD} \\ &= S_{ENOG} - S_{BMOG} - S_{ABCD} = -S_{ABCD} \end{aligned} \quad (21)$$

From (21), the energy loss of a system from state A to state E is the energy discharged out of the system with the decrease of intensive quantity and the original extensive quantity in AB process, whose amount equals

to area S_{ABCD} . In the BE process, the intensive quantity of the system continuously decreases while the extensive quantity increases, which means energy is continuously discharged by the original extensive quantity while the system acquires energy with the new extensive quantity at the same time. There is no energy exchange between the system and surrounding in this course, so the energy discharged by original extensive quantity with the decrease of intensive quantity is just used to increase the extensive quantity. Thus, the total energy in BE process remains unchanged.

3 The equivalent transfer equation of lumped element model

The original Kirchhoff's circuit laws are two equalities that deal with the current and potential difference (voltage) in the lumped element model of electrical circuits. The KIL and KEL of energy network also depend on the lumped element models being applicable. The characteristic equation of transfer line (pipe) is the equation describing the relationship between intensive quantity and extensive quantity in line (pipe), and the generalized characteristic equation of transfer lines (pipes) is derived here.

According to the generalized transfer equation of extensive quantity equation (4), the expression of extensive quantity flow H is equation (22).

$$H = J_x A = -KA \nabla X \quad (22)$$

where the subscript in (4) is omitted

In (22), A is the sectional area through which the extensive quantity flows. By integrating (22), we can obtain an equation expressing the relationship between the extensive and intensive quantity. Since K may or may not be a constant value, the two different situations should be discussed separately.

(a) If K is a constant value, such as the transfer process of electric energy and the transfer process of pressure energy with steady incompressible laminar flow, etc. By integrating (22), we get

$$\begin{aligned} H &= -KA \frac{dX}{dL} \Rightarrow \int_A^E \frac{H}{KA} dL = \int_A^E -dX \Rightarrow \frac{1}{KA} \int_A^E H dL = X_A - X_E \\ \Rightarrow H^* R &= X_A - X_E \quad R = \frac{L}{KA} \end{aligned} \quad (23)$$

where H^* is the Lagrange Mean Value of integral $\int_A^E H dL$, which is called the equivalent extensive quantity flow in the transfer process, and its value is decided by the intensive quantity difference between the two ends of a line (pipe) and the constant value R . R characterizes the resistance in the energy transfer process, herein generally referred to as energy resistance. R is the electrical resistance in the transfer process of electric energy, and it is the flow resistance in the transfer process of pressure energy.

(b) If K is not a constant value, while the energy transfer coefficient λ ($\lambda = KA$) is constant, such as the heat conduction process, we have

$$\begin{aligned} H &= -\frac{KXA}{X} \frac{dX}{dL} \Rightarrow \int_A^E \frac{H}{\lambda A} dL = \int_A^E -\frac{1}{X} dX \Rightarrow \frac{1}{\lambda A} \int_A^E H dL = \ln X_A - \ln X_E \\ \Rightarrow H^* R &= \ln X_A - \ln X_E \quad R = \frac{L}{\lambda A} \end{aligned} \quad (24)$$

where H^* is still the equivalent extensive quantity flow. However, the relationship between H and X is nonlinear in this case. In fact, H is linear with respect to $\ln X$. As for the transfer process that K and λ are both not constant, it can be equivalent to transfer processes with constant K and λ introduced in Section 2.2.

According to the above discussion, the equivalent extensive quantity flow H^* can be used to describe the transfer process in lines (pipes). In this way, the integral equation can be turned into algebraic equation, which is easier to be solved. The variation of energy in the equivalent transfer process is shown in Fig. 6.

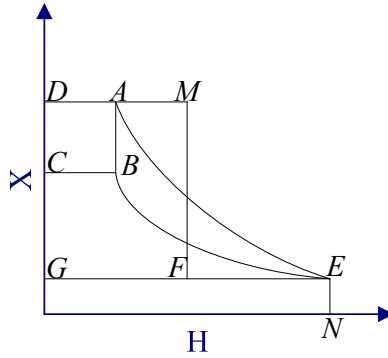

Fig.6 The equivalent transfer process diagram

Curve AE in Fig. 6 is the original transfer process. Because energy is a function of state, the variation of one energy form in a system is only related to its corresponding state parameters rather than the specific process of variation. The difference of energy between two states is just the value of energy variation in the system. Thus, the variation value of energy in process AE is equal to that in process ABE , and also equal to that in process $AMFE$. Supposing $H_{MF} = H^*$ in Fig. 6, which means the equivalent extensive quantity flow of equivalent transfer process $AMFE$ is H^* , this process can be described by using lumped element model.

The equivalent physical model of the process $AMFE$ is shown in figure 7.

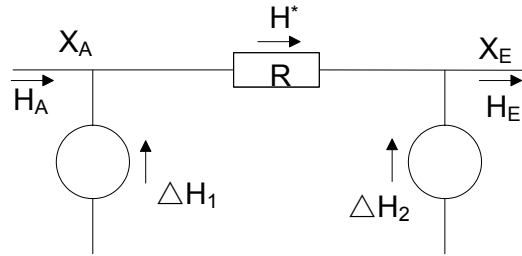

Fig.7 The physical model of equivalent transfer

With respect to the transfer process of electric energy and pressure energy in steady incompressible laminar flow, the current and the fluid flow keeps constant in the transfer process, hence

$\Delta H_1 = \Delta H_2 = 0$, and a linear relationship between H and X can be obtained:

$$H^* = H_1 = H_2 = \frac{X_1 - X_2}{R} \quad (25)$$

In the electric energy transfer process, (25) is just the Ohm's Law [8], where R is the resistance and H^* is the electric current.

In the transfer process of steady incompressible laminar flow, supposing the transfer coefficient of volume K_v to be constant and defining the flow resistance as $R_v = \frac{L}{K_v A}$, then equation $H_v = \frac{X_1 - X_2}{R_v}$ can be obtained.

The flow resistance of the laminar flow in the cylindrical transfer line (pipe) is [25,26]:

$$R_v = \frac{128\mu L}{\pi D^4} \quad (26)$$

In (26), μ is the dynamic viscosity of fluid, which is related to temperature and fluid type. Compared with the definition of flow resistance in (26), the transfer coefficient of volume is $K_v = \frac{D^2}{32\mu}$. K_v is constant for a certain fluid flowing in a certain transfer line (pipe), and this conclusion accords with the previous assumption.

Considering the constant temperature heat conduction in thermal energy transfer, in which case K is not a constant value, but the heat transfer coefficient λ ($\lambda = KX$) is constant, the following equation can be obtained according to (24):

$$H^*R = \ln X_A - \ln X_E \quad R = \frac{L}{\lambda A} \quad (27)$$

In (27), H^* is the equivalent to the entropy flow, while X denotes temperature. In constant temperature heat conduction process, heat flow is constant and the equation can be further deduced as follows:

$$\begin{aligned} P &= J_{en}A = XJ_xA = -KXA\nabla X = -\lambda A \frac{dX}{dL} \\ \Rightarrow \frac{P}{\lambda A} dL &= -dX \quad \Rightarrow P = \lambda A \frac{X_1 - X_2}{L} \end{aligned} \quad (28)$$

(28) is just the equation of one-dimensional constant temperature heat conduction in heat transfer theory.

There are various forms of energy used in engineering practice, but the energies transferred in network are mainly electric energy and thermal energy. Other forms of energy such as nuclear energy, wind energy, solar energy and hydropower energy are converted into electric energy or thermal energy before it is transferred. Thus the (25) is the key to model an energy network.

4 Analysis of a typical energy network

4.1 Formulation of the equation system of a typical energy network

The system formed by a combined cooling, heating and power (CCHP) generator in engineering practice is a typical energy network. In this section, a real CCHP system is modeled and analyzed, and experiments are carried out to validate the theoretical results.

The major equipment of this CCHP system includes: gas turbine, absorption-type refrigerating and electric refrigeration units, pump and so on. The electricity produced by the gas turbine is supplied to a multiple-use building, a laboratory building and a new building, and the shortage of electricity is complemented by an outside power grid. On the other hand, the cooling energy produced by absorption-type refrigerating unit is transferred to the multiple-use and new buildings, the lack of cooling energy is complemented by electric refrigeration. The system configuration diagram is shown in Fig. 8.

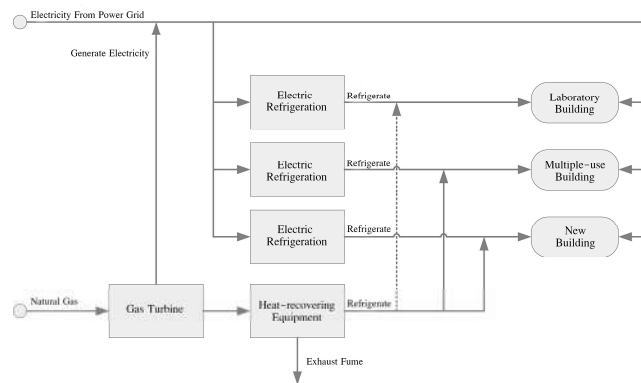

Fig.8 CCHP system configuration diagram

To facilitate modeling and analysis of the system, this paper commences the study on the system at 12pm on September 2, 2010. At the moment, since the absorption-type refrigerating unit provides cold energy to the new building only, the multiple-use and laboratory buildings are excluded in the model. As gas turbine is

connected to the main power grid, and then electricity supply of the system can be regarded as adequate; supply from the gas turbine and power grid can be regarded as the same electric energy source. According to the above configuration, the energy network diagram of the CCHP system is depicted as Fig. 9.

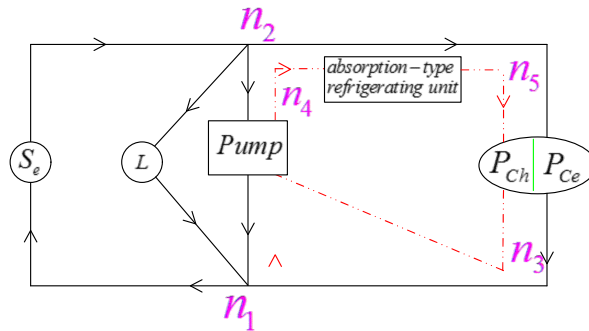

Fig.9 Energy network diagram of CCHP system

In Fig. 9, the solid lines denote the transfer route of electric energy within the electric network; dot dash lines denote the transfer route of cooling energy, which is carried by the water flow in the pipes of water network driven by pressure energy. Furthermore, electric network is linked with water network through pump and cooling load ($P_C = P_{Ch} + P_{Ce}$, where P_{Ch} is the cooling power supplied by the absorption-type refrigerating unit; P_{Ce} is the cooling power supplied by the electric refrigeration units; P_C is the total cooling power); users get the cooling energy through the heat exchanger. Although the cooling energy exists in the energy network, it has not yet formed a transfer network of its own (the transfer of cooling energy is implemented through water flow in the water network). S_e is electric energy source; L is other load of electric network; absorption-type refrigerating unit is the cooling energy source of the water network.

According to the basic network topology of the CCHP system shown in Fig. 9, the nodes, braches and network topologies can be simplified as Fig. 10.

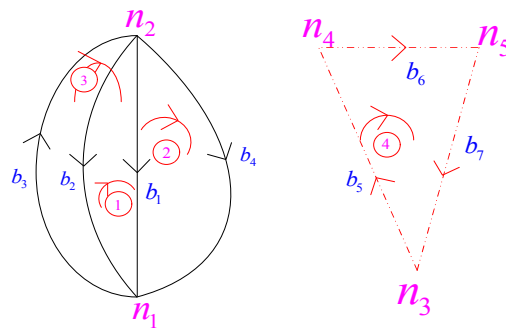

Fig.10 Simplified network diagram of CCHP system

Choosing n_1 , n_3 as reference node, the correlation matrix of this network can be written as

$$A = \begin{bmatrix} 1 & 1 & -1 & 1 & 0 & 0 & 0 \\ 0 & 0 & 0 & 0 & -1 & 1 & 0 \\ 0 & 0 & 0 & 0 & 0 & -1 & 1 \end{bmatrix}$$

The extensive quantity flow vector is:

$$\mathbf{H} = [H_1 \ H_2 \ H_3 \ H_4 \ H_5 \ H_6 \ H_7]^T$$

The basic circuit matrix is:

$$B_f = \begin{bmatrix} 1 & -1 & 0 & 0 & 0 & 0 & 0 \\ -1 & 0 & 0 & 1 & 0 & 0 & 0 \\ 1 & 0 & 1 & 0 & 0 & 0 & 0 \\ 0 & 0 & 0 & 0 & 1 & 1 & 1 \end{bmatrix}$$

The vector of intensive quantity difference between the two ends of lines (pipes) is:

$$\Delta X = [\Delta X_1 \quad \Delta X_2 \quad \Delta X_3 \quad \Delta X_4 \quad \Delta X_5 \quad \Delta X_6 \quad \Delta X_7]^T$$

According to the Generalized Kirchhoff's Law, the system of equations of this energy network can be written as:

$$\begin{cases} AH = 0 \\ B_f \Delta X = 0 \end{cases}$$

In this equation system, there are 7 equations and 14 unknown variables. Thus another 7 equations are required to solve this equation group. In Fig. 10, all branches, except the electric energy source branch b_3 , the pump branch b_5 , the branch b_1 showing electric energy transfer to pump and the electric cooler branch b_4 , can be described by the characteristic equations of transfer lines (pipes): $H_i = \frac{\Delta X_i}{R_i}$ ($i = 2, 6, 7$), $R_i = \frac{L_i}{K_i A_i}$. Thus, 3 equations can be obtained. According to the energy conservation law, an equation describing energy transfer between pump branch b_5 and branch b_1 : $\Delta X_5 H_5 + \eta \Delta X_1 H_1 = 0$ (η is energy conversion efficiency ratio of pump) is obtained. The equation of electric refrigeration branch b_4 can be written as $P_{ce} = COP \times \Delta X_4 H_4$. Hence we already have 12 equations.

Usually, the voltage of electric energy source branch (ΔX_3) is known. If P_{ch} is known, H_7 can be solved through equation $P_{ch} = \rho c \Delta T H_7$. Thus, the number of unknown variables in this energy network equation system becomes 12. With the above 12 equations, the equation system can be solved.

4.2 Numerical analysis of the energy network

Based on the theoretical analysis of the typical energy network in Section 4.1, the practical data of the CCHP system is used to analyze the energy network. When the total cooling load, voltage of the electric energy branch and parameters of lines (pipes) are known, the operating parameters of the pump and electric energy source can be solved.

For the typical energy network in Fig. 9, the known parameters include: total cooling load $P_c = 875.18KW$, cooling power of the absorption-type refrigerating unit $P_{ch} = 334.64KW$, and the cooling power of electric refrigeration unit $P_{ce} = 540.54KW$; the voltage of electric energy branch $\Delta X_3 = -230.19V$, $R_2 = R_L = 2.15\Omega$, $R_6 = 2.4 \times 10^6 Pa \cdot s / m^3$, $R_7 = 3.6 \times 10^6 Pa \cdot s / m^3$; R_4 is a variable resistance whose value affects the cooling power of electric refrigeration; the energy conversion efficiency of pump $\eta = 0.52$, the energy efficiency of electric refrigeration $COP = 4$. The solving steps include:

(1) Establishing the equation system of energy network

$$\begin{cases} AH = 0 \\ B_f \Delta X = 0 \end{cases}$$

(2) Formulating the characteristic equations of lines (pipes):

$$\Delta X_i = H_i R_i \quad (i = 2, 6, 7)$$

(3) Formulating the energy conservation equation

$$\Delta X_5 H_5 + \eta \Delta X_1 H_1 = 0$$

(4) Formulating the equation of electric refrigeration branch

$$P_{ce} = COP \times \Delta X_4 H_4$$

(5) Solving the extensive quantity flow H_7

As the cooling power of the absorption-type refrigerating unit $P_{Ch} = 334.64KW$ is already known, according to equation $P_{Ch} = \rho c \Delta T H_7$, the fluid flow $H_7 = 3.331 \times 10^{-2} m^3 / s$ can be obtained.

(6) Solving the equation system

As the units of voltage and pressure used in physics and engineering are different, the values of the two parameters cannot be compared directly. Also in order to simplify the calculation, this paper chooses the per-unit system used in electric power system analysis to solve the equation system, in which the system quantities are expressed as fractions of a defined base unit quantity [27]. The base intensive quantity (voltage and pressure) and extensive quantity (current and fluid flow) should be chosen first. The choice of base intensive quantity and extensive quantity should satisfy the energy conservation law.

The following base quantities are chosen in this paper: fluid flow base value $H_{PB} = 10^{-3} m^3 / s$, pressure base value $\Delta X_{PB} = 10^3 Pa$, voltage base value $\Delta X_{qB} = 230V$. Thus according to the energy conservation law, the current base value should be $H_{qB} = H_{PB} \times \Delta X_{PB} / \Delta X_{qB} = 1 / 230 A$. We can future calculate fluid flow resistance base value $R_{PB} = 10^6 Pa \cdot s / m^3$ and electrical resistance base value $R_{qB} = 5.29 \times 10^4 \Omega$. The per-unit values of the following practical data are calculated as:

$$\text{Total cooling load: } P_{Cs} = \frac{8.7518 \times 10^5 w}{10^3 \times 10^{-3} w} = 8.7518 \times 10^5$$

$$\text{Cooling power supplied by the water network: } P_{chs} = \frac{3.3464 \times 10^5 w}{10^3 \times 10^{-3} w} = 3.3464 \times 10^5$$

$$\text{Cooling power supplied by the electric network: } P_{Ces} = \frac{5.4054 \times 10^5 w}{10^3 \times 10^{-3} w} = 5.4054 \times 10^5$$

$$\text{Voltage: } \Delta X_{3s} = \frac{-230.19V}{230V} = -1.001$$

$$\text{Fluid flow: } H_{7s} = \frac{3.331 \times 10^{-2} m^3 / s}{10^{-3} m^3 / s} = 33.31$$

$$\text{Resistance: } R_{2s} = \frac{2.15 \Omega}{5.29 \times 10^4 \Omega} = 4.064 \times 10^{-5}$$

$$\text{Fluid flow resistance: } R_{6s} = \frac{2.4 \times 10^6 Pa \cdot s / m^3}{10^6 Pa \cdot s / m^3} = 2.4$$

$$R_{7s} = \frac{3.6 \times 10^6 Pa \cdot s / m^3}{10^6 Pa \cdot s / m^3} = 3.6$$

Solving the equation system, we can obtain:

$$\Delta X_s = [1.001 \quad 1.001 \quad -1.001 \quad 1.001 \quad -199.86 \quad 79.944 \quad 119.916]$$

$$H_s = [12789.8 \quad 24630.9 \quad 172420.7 \quad 135000 \quad 33.31 \quad 33.31 \quad 33.31]$$

By multiplying ΔX_s and H_s by the corresponding base values, we can obtain:

$$\Delta X = [230.23 \quad 230.23 \quad -230.23 \quad 230.23 \quad -199860 \quad 79944 \quad 119916]$$

$$H = [55.608 \quad 107.091 \quad 749.656 \quad 586.957 \quad 0.03331 \quad 0.03331 \quad 0.03331]$$

If the intensive quantities of reference nodes (n_1, n_3) are known, the intensive quantities of all nodes in energy network can be obtained. If the voltage of n_1 is its dead state value $0V$, the pressure of n_3 is its dead state value $10^5 Pa$, then the intensive quantities of the nodes are:

$$X = [0 \quad 230.23 \quad 100000 \quad 299860 \quad 219916]^T$$

4.3 Experimental verification of the energy network equations

Through the numerical analysis of the energy network, the calculated operating parameters of the CCHP system at a specific time are obtained. Then we can compare them with the data measured in the experiment. The vectors of intensive quantity difference and extensive quantity in the experiment on CCHP system are as follows:

$$\Delta X_a = [230.19 \quad 230.19 \quad -230.19 \quad 230.19 \quad -200000 \quad 80000 \quad 120000]$$

$$H_a = [58.26 \quad 107.087 \quad 770.565 \quad 605.2 \quad 0.03322 \quad 0.03322 \quad 0.03322]$$

The actual and calculated operating parameters are listed in Table 1, with the errors showing the difference between the actual and calculated operating parameters. The results show that absolute values of the errors are all within 5%. Since the analysis of the energy network is based on a steady state model, while the practical operating process is dynamic, the error between the calculated and actual data is acceptable. It implies that the energy network theories and equations are correct.

Table.1 Comparison of operation parameters

Parameters	Actual operating parameters	Calculated operating parameters	Error
ΔX_1	230.19	230.23	0.02%
ΔX_2	230.19	230.23	0.02%
ΔX_3	-230.19	-230.23	0.02%
ΔX_4	230.19	230.23	0.02%
ΔX_5	-200000	-199860	-0.07%
ΔX_6	80000	79944	-0.07%
ΔX_7	120000	119916	-0.07%
H_1	58.26	55.608	-4.55%
H_2	107.087	107.091	0.004%
H_3	770.565	749.656	-2.71%
H_4	605.2	586.957	-3.01%
H_5	0.03322	0.03331	0.27%
H_6	0.03322	0.03331	0.27%
H_7	0.03322	0.03331	0.27%

5 Conclusion

To cope with energy crisis and climate change, comprehensive utilization of energy in different forms has become an inevitable trend. In engineering practice, the production, transmission and utilization of energy are often accomplished by the means of energy networks such as electric power grid, heat supply network, gas network, etc. However, there is still no theory for general energy networks containing different forms of energies. The fundamental theory of energy networks is established following an in-depth analysis of the nature of energy and by consolidating the basic theories of Thermodynamics, Heat Transfer, Electric Network and Fluid Network. The State Principle, Energy Axiom, Transfer Axiom and the generalized Kirchhoff's laws are proposed as the fundamental for development of energy network theory and formulation of energy network equation system.

The generalized transfer equations of energy in wires (pipes) are proposed based on the generalized balance equation of energy in space, and the energy and exergy variation laws in the transfer processes are investigated. Because energy is a state quantity, the variation of energy in a system is only relevant to the intensive and extensive quantities at the initial and final states instead of the specific transfer process. In case that the initial and final states of different transfer processes are identical, the variations of energy transfer in these processes

are equivalent. Then the generalized equivalent energy transfer equations with lumped parameters are derived on basis of the characteristic equations of energy transfer in wires (pipes). As in the electric network theory, the equations are finally unified into a complete energy network equation system by using generalized Kirchhoff's laws and its solvability is further discussed.

Experiments are carried out on a CCHP system in engineering, the energy network theory proposed in this paper is used to model and analyze this system. By comparing the theoretical results obtained by our modeling approach and the data measured in experiments, the energy equations are validated.

References:

1. H. Cho, A. D. Smith, P. Mago, Combined cooling, heating and power: A review of performance improvement and optimization. *Appl. Energ.* **136**, 168-185 (2014).
2. Guide to the UK and Ireland energy networks, *Energy Networks Association*, <http://www.energynetworks.org/news/publications/guide-to-the-networks.html>
3. P. Favre-Perrod, A visions of future energy networks. Swiss Fed. Inst. of Technol., doi: 10.1109/PESA.FR.2005.1611778
4. M. Geidl, G. Koeppl, P. Favre-Perrod, B. Klockl, G. Andersson, K. Frohlich, Energy hubs for the future. *IEEE Power. Energy. M.* **5**, 24-30 (2007).
5. L. Carradore, F. Bignucolo, in *Universities Power Engineering Conference, 2008. UPEC 2008. 43rd International.* (2008), pp. 1-5.
6. T. Krause, G. Andersson, Fro, x, K. hlich, A. Vaccaro, Multiple-Energy Carriers: Modeling of Production, Delivery, and Consumption. *P. Ieee.* **99**, 15-27 (2011).
7. J. Fourier (translated by A. Freeman), *Analytical Theory of Heat* (The University Press, Cambridge, 1878).
8. G.S. Ohm (translated by W. Francis), *The Galvanic Circuit Investigated Mathematically* (D. Van Nostrand Company, New York, 1891)
9. T. N. Narasimhan, Fourier's heat conduction equation: History, influence, and connections, *Reviews of Geophysics*, **37**(1), 151-172 (2010).
10. J. L. M. Poiseuille, Recherches experimentales sur le mouvement des liquides dans les tubes de très petits diamètres, *Mem. Présentés Divers Savants Acad. R. Sci. Inst. France*, **9**, 1846. (English translation, W. H. Herschel, *Rheol. Mem.*, **1**(1), 1940.)
11. W. S. Ho, H. Hashim, M. H. Hassim, Z. A. Muis, N. L. M. Shamsuddin, Design of distributed energy system through Electric System Cascade Analysis (ESCA). *Appl. Energ.* **99**, 309-315 (2012).
12. P. Dondi, D. Bayoumi, C. Haederli, D. Julian, M. Suter, Network integration of distributed power generation. *J. Power. Sources.* **106**, 1-9 (2002).
13. National Science Foundation, Creating the energy Internet - How leaders in research, industry and engineering education are working to create the energy network of the future, Feb. 25 (2015), [online] http://nsf.gov/discoveries/disc_summ.jsp?cntn_id=134274&org=NSF
14. H. U. Fuchs, *The Dynamics of Heat* (Springer-Verlag, New York, 1996)
15. H. U. Fuchs, *The Dynamics of Heat - A Unified Approach to Thermodynamics and Heat Transfer* (second edition, Springer-Verlag, New York, 2010)
16. S.J. Kline, F.O. Koenig, The state principle - some general aspects of the relationship among the properties of systems. *J. Appl. Mech.* **24**, 1-6 (1957).
17. H.B. Callen, *Thermodynamics*, (Wiley, New York, 1960), pp. 12, 192.
18. R.W. Haywood, *Engineering Thermodynamics*, (Wiley, New York, 1980).
19. Moran MJ, Shapiro HN, *Fundamentals of engineering thermodynamics*, (Wiley, New York, 1995).
20. B. Hua, et al., in *ASME Annual Meeting, 1987*.
21. S. Wang, et al., in *TAISE'97 Thermodynamic Analysis and Improvement of Energy Systems.* (1997), pp. 25-30.
22. G. Han, thesis, South China University of Technology (2002) (In Chinese).
23. Z. Rant, Exergie, ein neues Wort für "technische Arbeitsfähigkeit" (Exergy, a new word for "technical available work"), *Forschung auf dem Gebiete des Ingenieurwesens*, **22**(14), 36-37 (1956).
24. N. Balabanian, T.A. Bichart, *Electric network theory* (Wiley, New York, 1969).
25. K. Foster, G.A. Parker, *Fluidics: Components and Circuits* (Wiley-Interscience, London, 1970).
26. D.A. Hullender, R.L. Woods, *Modeling of Fluidic Circuit Components* (Pergamon Press, Oxford, 1986).
27. D.P. Kothari, I.J. Nagrath, *Modern Power System Analysis* (Tata McGraw-Hill, USA, 2003).