

Quantum homomorphic encryption from quantum codes

Yingkai Ouyang and Si-Hui Tan

*Singapore University of Technology and Design, 8 Somapah Road, Singapore**

Joseph Fitzsimons

Singapore University of Technology and Design, 8 Somapah Road, Singapore and
Centre for Quantum Technologies, National University of Singapore, 3 Science Drive 2, Singapore*

The recent discovery of fully-homomorphic classical encryption schemes has had a dramatic effect on the direction of modern cryptography. Such schemes, however, implicitly rely on the assumptions that solving certain computation problems are intractable. Here we present a quantum encryption scheme which is homomorphic for arbitrary classical and quantum circuits which have at most some constant number of non-Clifford gates. Unlike classical schemes, the security of the scheme we present is information theoretic, satisfying entropic security definitions, and hence independent of the computational power of an adversary.

I. INTRODUCTION

Harnessing the power of quantum mechanics to build cryptosystems is a key motivation for developing quantum technologies. Quantum key distribution (QKD), pioneered by Bennett and Brassard [1] and Ekert [2], is an example of a quantum cryptographic primitive that offers functionality beyond that of classical cryptography. An advantage of quantum cryptography is that it often provides information-theoretic security guarantees that relies only the correctness of quantum mechanics, and so avoids the need for assumptions about the computational hardness of certain problems as in the case for many classical cryptographic protocols. There has been some amount of success in quantum approaches to cryptographic problems beyond key distribution, including secure randomness generation [3, 4], coin-flipping [5–7], secret sharing [8–10] and bit-commitment [11–14]. One area in particular that has seen significant progress in recent years is the development of quantum cryptographic protocols for delegated computation [15], which includes blind quantum computation [16–21], and verifiable quantum computation [22–25]. Homomorphic encryption has been recognised as an important primitive for building secure delegated computation protocols for many decades [26]. It provides a processing functionality for encrypted quantum data which stays secret during the evaluation, and a scheme is *fully-homomorphic* if it allows for arbitrary quantum computation. Despite widespread interest in this problem, it was not until 2009 that the first computationally secure classical scheme for fully homomorphic encryption (FHE) was discovered [27], with many improvements following rapidly from this initial discovery [28, 29]. This problem has recently drawn attention within the quantum information community [30–35], with natural questions arising as to whether quantum cryptosystems might offer unconditionally secure homomorphic encryption schemes and whether the privacy homomorphisms could be extended to allow for evaluation of quantum circuits.

Quantum homomorphic encryption (QHE) schemes comprise of four parts: key generation, encryption, evaluation, and decryption. Unlike blind quantum computation, in which the computation to be performed forms part of the secret, QHE schemes do not have secret circuit evaluations. They serve to obscure only the information that is contained within the state to be processed using the chosen circuit. The extent to which a scheme is secure depends on its specifics, and in previous work has varied depending on the precise nature of the computation which can be performed on the encrypted input. QHE schemes described in Refs. [34, 35] offer some information theoretic security, but this is only in the form of a gap between the information accessible with and without the secret key, a notion of security which does not imply the stronger notion of security under composition. These schemes are also limited in the set of operations that can be performed on the encrypted data. The scheme in [34] only allows computations in the BosonSampling model, while that in [35] does not offer any known encoding for universal quantum computing. A hybrid scheme offered by [36] serves to remove the need for any interactions but requires bootstrapping onto a classical fully homomorphic encryption scheme and as such is only computationally secure. Several other schemes for computing on encrypted data have previously been introduced which offer universal quantum computation, but require interactions between the client and evaluator [30–33]. This requirement for interaction places them outside of the formalism of homomorphic encryption, although confusingly several of these schemes use that terminology

*Electronic address: yingkai_ouyang@sutd.edu.sg

[30, 31].

The difficulty in creating a perfectly secure quantum fully homomorphic encryption (QFHE) scheme persists, and is in line with the no-go result provided by [37] that perfect information-theoretic security whilst enabling arbitrary processing of encrypted data is impossible, unless the size of the encoding grows exponentially. Nonetheless, given the growing interest in QHE schemes and the multitude of possibilities, Broadbent and Jeffrey set out to provide a rigorous framework for defining QHE schemes [36], basing their security definitions on the requirement for indistinguishability of codewords under chosen plaintext attack.

II. SUMMARY OF RESULTS

Our main result is a family of quantum homomorphic encryption schemes, presented in Cryptosystem 1, which supports the evaluation of quantum circuits containing at most some constant number of non-Clifford group gates. This scheme is proven to be secure in an entropic model which is strictly stronger than the security conditions laid down in [36]. The QHE scheme we present is a symmetric-key homomorphic encryption protocol that supports evaluation of constant T -depth quantum circuits while providing strong information theoretic security guarantees. It builds on constructions taken from quantum error correction codes to provide gates for universal quantum computation. The block of qubits that contains the code is embedded in a much larger set of qubits that are initialized in a maximally mixed state. The qubits are then shuffled in a specific but random way to hide the qubits that contain that code. Our protocol guarantees that the trace distance between ciphertexts corresponding to any two quantum inputs is exponentially suppressed. This is a significantly stronger security guarantee than previous homomorphic encryption schemes presented in [34]. Moreover the computation power of our scheme is equivalent to that of Broadbent and Jeffrey's while not needing to bootstrap on the classical homomorphic encryption scheme. This use of classical fully homomorphic encryption is the weakest link in the Broadbent-Jeffery cryptosystem, since it introduces a reliance on computational assumptions [44].

Formally, the QHE scheme we present in Cryptosystem 1 satisfies the following theorem.

Theorem 1. *Let b, r, n, m be positive integers where $n = 4n' + 1$ for some positive integer n' , and let t be a non-negative integer. Let γ denote the fixed tuple of integers (b, r, t, n, m) . Let κ be the symmetric key of our scheme, chosen uniformly at random from the symmetric group of order $n + m$. Then \mathcal{Q}_γ is a QHE scheme satisfying the following properties:*

- *Completeness* — Let ρ_{input} be any r -qubit state, and let $\rho_t = (TH|0\rangle\langle 0|H^\dagger T^\dagger)^{\otimes t}$, where T is the $\frac{\pi}{8}$ -gate and H is the Hadamard gate. Let (V_1, \dots, V_d) be any sequence of unitaries on r qubits comprising of single qubit Clifford gates, two-qubit CNOTs, and exactly t single qubit T gates. Then for every $\kappa \in S_{n+m}$,

$$(\rho_{\text{output}}, f) = \text{Dec}_\gamma\left(\kappa, \text{Eval}_\gamma((V_1, \dots, V_d), \text{Enc}_\gamma(\kappa, (\rho_{\text{input}} \otimes \rho_t)^{\otimes b}))\right) \quad (1)$$

yields the correct output $\rho_{\text{output}} = V_d \dots V_1 \rho_{\text{input}} V_1^\dagger \dots V_d^\dagger$ except with probability at most δ in which case a heralded failure $f = 0$ results, where

$$\delta = \begin{cases} 0 & , t = 0 \\ \exp(-b2^{-2t+1} + \sqrt{b}2^{-t+2} - 2) & , t \geq 1. \end{cases} \quad (2)$$

- *Security* — Without knowledge of the symmetric key, the trace distance δ between any two encrypted inputs is exponentially small. Namely, for all $b(r+t)$ -qubit density matrices τ and τ' , we have

$$\begin{aligned} \epsilon &= \left\| \frac{1}{(n+m)!} \sum_{\kappa \in S_{n+m}} \text{Enc}_\gamma(\kappa, \tau) - \frac{1}{(n+m)!} \sum_{\kappa \in S_{n+m}} \text{Enc}_\gamma(\kappa, \tau') \right\|_{\text{tr}} \\ &\leq e \left(\frac{8n}{\pi(1 + \frac{1}{\alpha})} \right)^{1/4} 4^{b(r+t)} \exp\left(-\frac{m}{2} \ln(1 + \frac{1}{\alpha}) - \frac{n}{2} \ln(1 + \alpha)\right), \end{aligned} \quad (3)$$

where $\alpha = \frac{m}{n}$. In particular when $\alpha = \frac{m}{n}$ approaches a positive constant for large n , ϵ is exponentially suppressed in n .

- *Compactness* — The maximum circuit size needed to implement the encryption and the decryption is at most polynomial in the parameters of γ , and independent of the circuit to be implemented, provided that it makes use of at most t single qubit T -gates.

III. PRELIMINARIES

Let \mathbb{Z}_+ denote the set of positive integers. For all $n, n_1, n_2 \in \mathbb{Z}_+$ such that $n_1 \leq n_2$ we define $[n] = \{1, \dots, n\}$, and $[n_1 : n_2] = \{n_1, \dots, n_2\}$. Given any two sets \mathcal{X} and \mathcal{Y} , define $\mathcal{X} - \mathcal{Y} = \{x \in \mathcal{X} : x \notin \mathcal{Y}\}$.

For qubits arranged on a grid with p rows and q columns, let $\mathcal{H}_{(x,y)}$ denote the Hilbert space of the qubit located at position (x, y) , where (x, y) denotes the x -th row and the y -th column, where $x \in [p]$ and $y \in [q]$. For all $\mathcal{L} \subset [p] \times [q]$, define $\mathcal{H}^{\mathcal{L}} = \bigotimes_{(x,y) \in \mathcal{L}} \mathcal{H}_{(x,y)}$. We denote the Hilbert space of the grid of the pq qubits as $\mathcal{H}^{p,q} = \mathcal{H}^{[p] \times [q]}$.

Given a Hilbert space \mathcal{H} , we let $L(\mathcal{H})$ denote the set of linear operators mapping \mathcal{H} to \mathcal{H} . We let $D(\mathcal{H})$ denote the set of density matrices in $L(\mathcal{H})$, that is the set of positive semidefinite operators in $L(\mathcal{H})$ with unit trace. For any Hilbert space admitting a tensor product structure $\mathcal{K}_1 \otimes \mathcal{K}_2$, we define the corresponding partial trace by $\text{Tr}_{\mathcal{K}_1}$ as the unique linear operator such that for all $K_1 \in L(\mathcal{K}_1)$ and $K_2 \in L(\mathcal{K}_2)$ we have $\text{Tr}_{\mathcal{K}_1}(K_1 \otimes K_2) = K_2 \text{Tr}(K_1)$, and Tr is the usual trace operator. Also define the partial trace on the complementary space to be such that for all $K_1 \in L(\mathcal{K}_1)$ and $K_2 \in L(\mathcal{K}_2)$ we have $\overline{\text{Tr}}_{\mathcal{K}_1}(K_1 \otimes K_2) = K_1 \text{Tr}(K_2)$.

Let $I = \sigma_0 = |0\rangle\langle 0| + |1\rangle\langle 1|$, $X = \sigma_1 = |0\rangle\langle 1| + |1\rangle\langle 0|$, $Z = \sigma_3 = |0\rangle\langle 0| - |1\rangle\langle 1|$ and $Y = \sigma_2 = i\sigma_1\sigma_3$ denote the usual Pauli matrices in $L(\mathbb{C}^2)$, where $\{|0\rangle, |1\rangle\}$ is an orthonormal basis of \mathbb{C}^2 . Let $H = \frac{1}{\sqrt{2}}(X + Z)$, $S = |0\rangle\langle 0| + i|1\rangle\langle 1|$ and $T = |0\rangle\langle 0| + e^{i\pi/4}|0\rangle\langle 0|$. We denote the set of single-qubit Clifford gates as $\mathcal{G} = \{I, X, Y, Z, H, S\}$. Define the magic state $|T\rangle = TH|0\rangle$.

For all $G \in L(\mathbb{C}^2)$, denote $[G]_{(x,y)} \in L(\mathcal{H}_{(x,y)})$ as the linear operator G operating on the qubit at (x, y) . Now let \mathcal{L} be any subset of $[p] \times [q]$. Define $I^{\mathcal{L}} = \bigotimes_{(x,y) \in \mathcal{L}} [I]_{(x,y)}$. For all (x, y) in \mathcal{L} , define the operator that implements G on the qubit at (x, y) and acts trivially on all other qubits labeled by \mathcal{L} to be

$$[G]_{(x,y)}^{\mathcal{L}} = [G]_{(x,y)} \otimes [I]^{\mathcal{L} - \{(x,y)\}}.$$

We denote $C_{(x,y),(x',y')} \in L(\mathcal{H}_{(x,y)} \otimes \mathcal{H}_{(x',y')})$ as a CNOT performed between the control qubit (x, y) and target qubit (x', y') . For all distinct (x, y) and (x', y') in \mathcal{L} , define

$$C_{(x,y),(x',y')}^{\mathcal{L}} = C_{(x,y),(x',y')} \otimes [I]^{\mathcal{L} - \{(x,y),(x',y')\}}.$$

We also denote $C_{x,(y,y')}^{\{x\} \times [y_1:y_2]} = C_{(x,y),(x,y')}^{\{x\} \times [y_1:y_2]}$, $C_{(x,x'),y}^{\{x_1:x_2\}} = C_{(x,y),(x',y)}^{\{x_1:x_2\} \times \{y\}}$ and $C_{(x,y),(x',y')}^{p,q} = C_{(x,y),(x',y')}^{[p] \times [q]}$.

For arbitrary positive integers p and q , let $\mathcal{M}_{p,q}$ denote the set of matrices with entries chosen from the set $\{0, 1, 2, 3\}$ and with p rows and q columns. Let $[\mathbf{1}_j \mathbf{0}_{j'}] \in \mathcal{M}_{1,j+j'}$ denote a row vector with each of its first j components equal to 1 and the remaining components equal to zero. For every $A \in \mathcal{M}_{p,q}$ let $A(x, y)$ denote the entry in the x -th row and the y -th column of the matrix A . For all $A \in \mathcal{M}_{p,q}$, define

$$\sigma_A = \bigotimes_{y=1}^q \left(\bigotimes_{x=1}^p [\sigma_{A(x,y)}]_{(x,y)} \right). \quad (4)$$

Let S_q denote the symmetric group of order q . Let $\varphi_{p,q}$ be a representation of S_q such that for every permutation $\pi \in S_q$ and every $A \in \mathcal{M}_{p,q}$,

$$\varphi_{p,q}(\pi) \sigma_A \varphi_{p,q}(\pi)^\dagger = \bigotimes_{y=1}^q \left(\bigotimes_{x=1}^p [\sigma_{A(x,y)}]_{(x,\pi(y))} \right). \quad (5)$$

IV. QUANTUM HOMOMORPHIC ENCRYPTION

We introduce a symmetric-key quantum homomorphic encryption (QHE) scheme, consistent with the definition introduced by Broadbent and Jeffery [36]. The scheme is parameterised by a tuple of positive integers $\gamma = (b, r, t, n, m)$. Here r represents the number of qubits in the input, t the number of non-Clifford (T) gates supported by the encoding, n the length of the random error correction code used in the encoding and m the number of random ancilla qubits per logical qubit encoded. Finally, b represents the number of copies of the input that are encoded, and is used to amplify the success probability for evaluation of T gates.

Our QHE scheme \mathcal{Q}_γ given explicitly in Cryptosystem 1 comprises of key generation, encryption, evaluation and decryption algorithms. We denote the state to be encrypted as $\tau \in D(\mathcal{H}^{b(r+t),1})$, which is composed of b copies of the plaintext state ρ_{input} together with bt magic states used to implement T gates via gate teleportation. The sequence of gates comprising the circuit to be evaluated is denoted as $(V_1, \dots, V_d) \in L(\mathcal{H}^{r,1})^d$, and the circuit to be evaluated

is $V = V_1 \dots V_d$. Here, each V_i is either a single-qubit Clifford gate, a single-qubit T gate, or a CNOT acting on a pair of qubits. Moreover, the quantum circuit V comprises of exactly t single-qubit T -gates.

Now let $\beta \in [b]$ be an index labeling the β -th copy, $x \in [r+t]$ be a row label within a specified copy, and $\text{row}(\beta, x) = (\beta-1)(r+t) + x$ denote the x -th row in β -th copy. Using the singleton set $\mathcal{X}_{\beta,x} = \{\text{row}(\beta, x)\}$, we define (i) the set $\mathcal{X}_{\text{magic},\beta} = \bigcup_{x=r+1}^{r+t} \mathcal{X}_{\beta,x}$ which labels the last t rows within the β -th copy to be used for implementing the privacy homomorphisms of the T -gate, (ii) the set $\mathcal{X}_{\text{other},\beta} = \bigcup_{x=1}^r \mathcal{X}_{\beta,x}$ which labels the rows within the β -th copy used for the r data qubits, (iii) the set $\mathcal{X}_\beta = \bigcup_{x=1}^{r+t} \mathcal{X}_{\beta,x}$ which labels all rows within the β -th copy, (iv) the set $\mathcal{X}_{(:,x)} = \bigcup_{\beta=1}^b \mathcal{X}_{\beta,x}$ which labels the x -th row of every copy, and (v) the set $\mathcal{X}_{\text{magic}} = \bigcup_{\beta=1}^b \mathcal{X}_{\text{magic},\beta}$ which labels the last t rows of every copy. For our QHE scheme to work, we require that an input state τ be prepared from b copies of ρ_{input} having the form

$$\tau = \bigotimes_{\beta=1}^b \left(\rho_{\text{input},\beta} \otimes \left(\bigotimes_{x \in \mathcal{X}_{\text{magic},\beta}} [|T\rangle\langle T|]_{(x,1)} \right) \right). \quad (6)$$

Here, $\rho_{\text{input},\beta}$ denotes the β -th copy of ρ_{input} , and each $\rho_{\text{input},\beta}$ has the explicit Pauli-decomposition

$$\rho_{\text{input},\beta} = \sum_{A \in \mathcal{M}_{r,1}} \frac{a_A}{2^r} \bigotimes_{x \in \mathcal{X}_{\text{other},\beta}} [\sigma_{A(x,1)}]_{(x,1)} \quad (7)$$

for some real constants a_A . Note that each r -qubit state $\rho_{\text{input},\beta}$ in $D(\mathcal{H}^{\mathcal{X}_{\text{other},\beta} \times \{1\}})$ for all $\beta \in [b]$ is prepared as an independent and identical copy of ρ_{input} , and every other input qubit is initialized in the magic state $|T\rangle\langle T|$.

In the encryption procedure of Cryptosystem 1, the quantum channel $\mathcal{E} : D(\mathcal{H}^{b(r+t),1}) \rightarrow D(\mathcal{H}^{b(r+t),n+m})$ has the definition where

$$\mathcal{E}(\tau) = \tau \otimes \left(\bigotimes_{y=2}^{n+m} \bigotimes_{x=1}^{b(r+t)} [I/2]_{(x,y)} \right), \quad (8)$$

introduces $n+m-1$ more columns to the system, initializing each newly introduced qubit in a maximally mixed state. For all $x \in [b(r+t)]$, the quantum information in each qubit on the x -th row in the first column is encoded into a quantum code via a unitary

$$U_x = \left(C_{x,(1,2)}^{\{x\} \times [n]} \dots C_{x,(1,n)}^{\{x\} \times [n]} \right) \left(C_{x,(2,1)}^{\{x\} \times [n]} \dots C_{x,(n,1)}^{\{x\} \times [n]} \right), \quad (9)$$

as depicted in Figure 1. In our scheme, U_x is applied to the first n columns and puts the qubits in each row into a random quantum code. We denote this unitary operation as v

$$U = \left(\bigotimes_{\beta=1}^b \bigotimes_{x=1}^{r+t} U_{\text{row}(\beta,x)} \right) \otimes [I]^{[b(r+t)] \times [n+1:n+m]}. \quad (10)$$

Since each U_x encodes the first n qubits in the x -th row into a random quantum code, a random subspace of $\mathcal{H}^{\{x\} \times [n]}$ consistent with the encoding U_x , the resultant quantum information resides in a random codespace. For odd n , the logical X and Z operators for each logical qubit on the x -th row are encoded as $\bar{X} = U_x^\dagger [X]_{(x,1)}^{\{x\} \times [n]} U_x$ and $\bar{Z} = U_x^\dagger [Z]_{(x,1)}^{\{x\} \times [n]} U_x$ respectively, where the bar signifies that the same Pauli operator is applied to every physical qubit comprising that logical qubit. By using the commutation relations

it is easy to see that for $G \in \{X, Z\}$ and for odd n , the corresponding logical operators have the form

$$\bar{G}_x = U_x^\dagger [G]_{(x,1)}^{\{x\} \times [n]} U_x = U_x [G]_{(x,1)}^{\{x\} \times [n]} U_x^\dagger = \bigotimes_{y=1}^n [G]_{(x,y)}. \quad (11)$$

Cryptosystem 1 QHE scheme \mathcal{Q}_γ , $\gamma = (b, r, t, n, m)$

$\kappa \leftarrow \text{KeyGen}_\gamma$
 $\tilde{\rho} \leftarrow \text{Enc}_\gamma(\kappa, \tau)$
 $\nu \leftarrow \text{Eval}_\gamma((V_1, \dots, V_d), \tilde{\rho})$
 $(\rho_{\text{out}}, f) \leftarrow \text{Dec}_\gamma(\kappa, \nu)$

definitions

$p = b(r + t)$
 $U_x = \left(C_{x,(1,n)}^{\{x\} \times [n]} \dots C_{x,(1,2)}^{\{x\} \times [n]} \right) \left(C_{x,(2,1)}^{\{x\} \times [n]} \dots C_{x,(n,1)}^{\{x\} \times [n]} \right)$ for $x = 1, \dots, p$
 $U = \bigotimes_{\beta=0}^{b-1} \bigotimes_{x=1}^{r+t} U_{\beta(r+t)+x} \otimes [I]^{[p] \times [n+1:n+m]}$

end definitions**procedure KEYGEN $_\gamma$**

Pick $\kappa \in S_{n+m}$ uniformly at random.

return κ

end procedure

▷ Generate symmetric key

procedure ENC $_\gamma(\kappa, \tau)$

$\tau \leftarrow \mathcal{E}(\tau) = \tau \otimes \left(\bigotimes_{y=2}^{n+m} \bigotimes_{x=1}^p [I/2]_{(x,y)} \right)$

$P_\kappa \leftarrow \varphi_{p,n+m}(\kappa)$

$\tau \leftarrow U \tau U^\dagger$

return $P_\kappa \tau P_\kappa^\dagger$.

end procedure

▷ Encryption

procedure EVAL $_\gamma((V_1, \dots, V_d), \tilde{\rho})$

$\nu \leftarrow \tilde{\rho}$, $\alpha \leftarrow 1$

for $i = 1, \dots, d$ **do**

if $V_i = [G]_{(x,1)}^{r,1}$ where $G \in \mathcal{G}$ **then**

$\nu \leftarrow (G_x^{\text{Eval}}) \nu (G_x^{\text{Eval}})^\dagger$

else if $V_i = C_{(x,1),(x',1)}^{r,1}$ **then**

$\nu \leftarrow (C_{x,x'}^{\text{Eval}}) \nu (C_{x,x'}^{\text{Eval}})^\dagger$

else

$\nu \leftarrow (C_{x,r+\alpha}^{\text{Eval}}) \nu (C_{x,r+\alpha}^{\text{Eval}})^\dagger$

$\nu \leftarrow (C_{r+\alpha,x}^{\text{Eval}}) \nu (C_{r+\alpha,x}^{\text{Eval}})^\dagger$

$\alpha \leftarrow \alpha + 1$

end if

end for

return ν

end procedure

▷ Evaluation

▷ 1-qubit Clifford

▷ CNOT

▷ T gate**procedure DEC $_\gamma(\kappa, \nu)$**

$\bar{b} \leftarrow (r + t)$

$P_\kappa \leftarrow \varphi_{p,n+m}(\kappa)$

$\tau' \leftarrow U^\dagger P_\kappa^\dagger \nu P_\kappa U$

for $\beta = 1, \dots, b$ **do**

if $t = 0$ **then** $c_\beta \leftarrow 0$

else

for $i = 1, \dots, t$ **do**

$c_{\beta,i} \leftarrow \text{Measure } \tau' \text{ with operator } [Z]_{(\beta(r+t)-t+i,1)}$.

end for

$c_\beta \leftarrow \sum_{i=1}^t (1 - c_{\beta,i}) / 2$

end if

end for

if $\min_\beta c_\beta \geq 1$ **then**

return $(\overline{\text{Tr}}_{\mathcal{H}^{[r] \times \{1\}}} \tau', 0)$

else

Let α be the smallest integer such that $c_\alpha = 0$.

$\mathcal{L} \leftarrow [(\alpha - 1)(r + t) + 1 : (\alpha - 1)(r + t) + r] \times \{1\}$

return $(\overline{\text{Tr}}_{\mathcal{H}^{\mathcal{L}}} \tau', 1)$

end if

end procedure

▷ Decryption

▷ Failure

▷ Success

We also have the encoded Y operator,

$$\begin{aligned}\bar{Y}_x &= U_x^\dagger [Y]_{(x,1)}^{\{x\} \times [n]} U_x = U_x^\dagger [iXZ]_{(x,1)}^{\{x\} \times [n]} U_x \\ &= iU_x^\dagger [X]_{(x,1)}^{\{x\} \times [n]} [Z]_{(x,1)}^{\{x\} \times [n]} U_x \\ &= iU_x^\dagger [X]_{(x,1)}^{\{x\} \times [n]} U_x U_x^\dagger [Z]_{(x,1)}^{\{x\} \times [n]} U_x = i^{1-n} \bigotimes_{y=1}^n [Y]_{(x,y)} = \bigotimes_{y=1}^n [Y]_{(x,y)},\end{aligned}\quad (12)$$

where the last equality follows when $n-1$ is divisible by 4. Similarly we get $U_x [Y]_{(x,1)}^{\{x\} \times [n]} U_x^\dagger = \bigotimes_{y=1}^n [Y]_{(x,y)} = \bar{Y}_x$. Thus the logical X , Y and Z operators of our random code on the x -th row are just given by their corresponding transversal gates. These logical operators satisfy the usual commutation relations among themselves because commutation and anti-commutation are preserved under unitary conjugation. At this juncture, it is useful to observe the following property: the $b(r+t)$ -qubit input state τ in $D(\mathcal{H}^{r,1})$ is mapped by the encoding operation \mathcal{E} to a density matrix $\mathcal{E}(\tau)$ with decomposition

$$\mathcal{E}(\tau) = \sum_{\substack{\mathbf{v} \in \mathcal{M}_{b(r+t),1} \\ A = \mathbf{v}[\mathbf{1}_n \mathbf{0}_m]}} \frac{r_{\mathbf{v}}}{2^{b(r+t)(n+m)}} \sigma_A, \quad (13)$$

for suitable constants $r_{\mathbf{v}}$. We will use this property in Lemma 4 to prove the security of our scheme. Now for all $x \in [b(r+t)]$ define

$$\bar{H}_x = \bigotimes_{y \in [n]} [H]_{(x,y)}, \quad \bar{S}_x = \bigotimes_{y \in [n]} [S]_{(x,y)}. \quad (14)$$

It is easy to see that $\bar{H}_x \bar{X}_x \bar{H}_x^\dagger = \bar{Z}_x$, $\bar{H}_x \bar{Z}_x \bar{H}_x^\dagger = \bar{X}_x$, Since $n-1$ is divisible by 4, we also have $\bar{H}_x \bar{Y}_x \bar{H}_x^\dagger = \bar{H}_x (i^n \bar{X}_x \bar{Z}_x) \bar{H}_x^\dagger = -\bar{Y}_x$. Similarly, $\bar{S}_x \bar{X}_x \bar{S}_x^\dagger = \bar{Y}_x$, $\bar{S}_x \bar{Y}_x \bar{S}_x^\dagger = -\bar{X}_x$, and $\bar{S}_x \bar{Z}_x \bar{S}_x^\dagger = \bar{Z}_x$. Hence the non-trivial single logical qubit Clifford operations in the codespace on the x -th row are given by $\bar{X}_x, \bar{Y}_x, \bar{Z}_x, \bar{H}_x, \bar{S}_x$. It also follows that the logical CNOT with control on the x -th row and target on the x' -th row is given by

$$\bar{C}_{x,x'} = \bigotimes_{y \in [n]} C_{(x,y),(x',y)}. \quad (15)$$

Since we have also shown that for $n-1$ divisible by 4 and $G \in \{X, Y, Z, H, S\}$,

$$\bar{G}_x = U_x^\dagger [G]_{(x,1)}^{\{x\} \times [n]} U_x = U_x [G]_{(x,1)}^{\{x\} \times [n]} U_x^\dagger = \bigotimes_{y=1}^n [G]_{(x,y)}, \quad (16)$$

all logical Clifford gates using are transversal, that is, they are tensor products of identical operators over the columns of the qubits. A random permutation of the columns according to κ then completes the encryption procedure of our quantum homomorphic scheme.

To perform the evaluation, we require the definition of the following operators. For all distinct z and z' in $[r+t]$, and for all $G \in \mathcal{G}$, define the linear operators $G_z^{\text{Eval}}, C_{z,z'}^{\text{Eval}} \in L(\mathcal{H}^{b(r+t),n+m})$ where

$$G_z^{\text{Eval}} = \bigotimes_{\beta=1}^b \bigotimes_{y=1}^{n+m} [G]_{(\text{row}(\beta,x),y)}^{\mathcal{X}_\beta \times \{y\}}, \quad C_{z,z'}^{\text{Eval}} = \bigotimes_{\beta=1}^b \bigotimes_{y=1}^{n+m} C_{(\text{row}(\beta,x),y),(\text{row}(\beta,x'),y)}. \quad (17)$$

Let $\mathcal{Y}_\kappa = \kappa([n])$ label the columns where the encrypted data resides and let $\bar{\mathcal{Y}}_\kappa = [n+m] - \mathcal{Y}_\kappa$ label the remaining columns. Also define

$$G_z^{\text{code},\kappa} = \bigotimes_{\beta=1}^b \bigotimes_{y \in \mathcal{Y}_\kappa} [G]_{(\text{row}(\beta,z),y)}^{\mathcal{X}_\beta \times \{y\}}, \quad C_{z,z'}^{\text{code},\kappa} = \bigotimes_{\beta=1}^b \bigotimes_{y \in \mathcal{Y}_\kappa} [C]_{(\text{row}(\beta,z),y),(\text{row}(\beta,z'),y)}, \quad (18)$$

and

$$G_z^{\text{anc},\kappa} = \bigotimes_{\beta=1}^b \bigotimes_{y \in \bar{\mathcal{Y}}_\kappa} [G]_{(\text{row}(\beta,z),y)}^{\mathcal{X}_\beta \times \{y\}}, \quad C_{z,z'}^{\text{anc},\kappa} = \bigotimes_{\beta=1}^b \bigotimes_{y \in \bar{\mathcal{Y}}_\kappa} [C]_{(\text{row}(\beta,z),y),(\text{row}(\beta,z'),y)}. \quad (19)$$

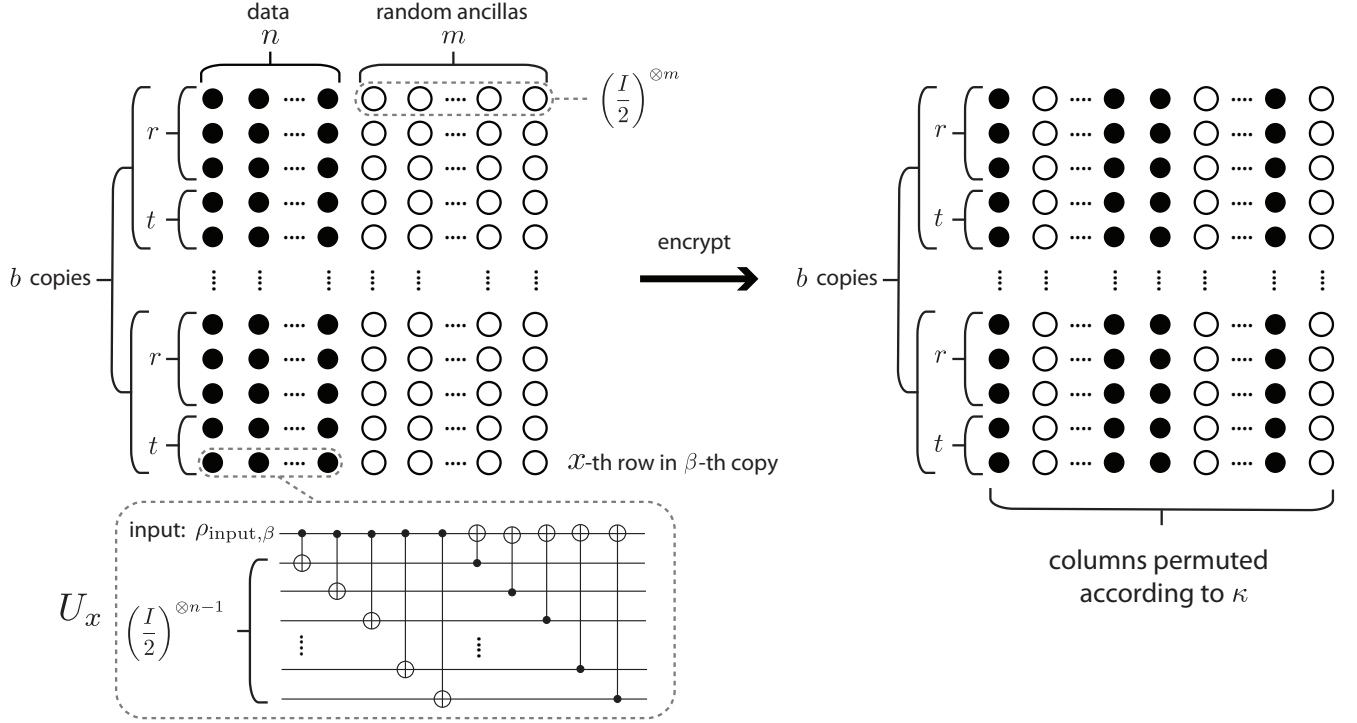

FIG. 1: Figure shows qubits arranged on a grid with rows and columns with shaded circles representing data qubits, and unshaded circles representing ancilla qubits. A qubit in the x -th row and y -th column is addressed by (x, y) . Within each row, the n data qubits are in a code and the m ancilla qubits are in the completely mixed state. There are r sets of codes, and b copies of such sets. The copies exist to ensure that there is a high probability that at least one of the copies implement the correct quantum circuit (see Lemma 3). U_x encodes the n data qubits in the x -th row into a random quantum code. A random permutation of the columns completes the encryption procedure of our quantum homomorphic encryption scheme.

Then we have the tensor product decompositions

$$G_z^{\text{Eval}} = G_z^{\text{code},\kappa} \otimes G_z^{\text{anc},\kappa}, \quad C_{z,z'}^{\text{Eval}} = C_{z,z'}^{\text{code},\kappa} \otimes C_{z,z'}^{\text{anc},\kappa}. \quad (20)$$

Note from eq. (17) that $G_z^{\text{code},\kappa}$ and $C_{z,z'}^{\text{code},\kappa}$ admit a tensor product decomposition over b copies and hence

$$G_z^{\text{code},\kappa} = \bigotimes_{\beta=1}^b G_z^{\text{code},\beta,\kappa}, \quad C_{z,z'}^{\text{code},\kappa} = \bigotimes_{\beta=1}^b C_{z,z'}^{\text{code},\beta,\kappa}, \quad (21)$$

where

$$G_z^{\text{code},\beta,\kappa} = \bigotimes_{y \in \mathcal{Y}_\kappa} [G]_{(z,y)}^{\mathcal{X}_\beta \times \{y\}}, \quad C_{z,z'}^{\text{code},\beta,\kappa} = \bigotimes_{y \in \mathcal{Y}_\kappa} C_{(z,y),(z',y)}^{\mathcal{X}_\beta \times \{y\}}. \quad (22)$$

We similarly define the operators

$$G_z^{\text{code}} = \bigotimes_{\beta=1}^b G_z^{\text{code},\beta}, \quad C_{z,z'}^{\text{code}} = \bigotimes_{\beta=1}^b C_{z,z'}^{\text{code},\beta}, \quad (23)$$

where

$$G_z^{\text{code},\beta} = \bigotimes_{y \in [n]} [G]_{(z,y)}^{\mathcal{X}_\beta \times \{y\}}, \quad C_{z,z'}^{\text{code},\beta} = \bigotimes_{y \in [n]} C_{(z,y),(z',y)}^{\mathcal{X}_\beta \times \{y\}}. \quad (24)$$

At this stage, it is not clear *a priori* that the Eval_γ operator presented in Cryptosystem 1 results in the undiscarded copies, after the decryption procedure is applied, containing quantum data with V actually implemented. Such a circuit is in fact applied with high probability, as long as the number of copies b is sufficiently large as given in Lemma 3. Since the evaluator only applies transversal gates, these gates must commute with the secret permutation of the columns of the qubits on the grid. Moreover the ancilla qubits are initialized in the maximally mixed state, which implies that the effect of the evaluator's gates G_x^{Eval} and $C_{x,x'}^{\text{Eval}}$ after the columns are unpermuted is equivalent to applying operations $\bigotimes_{\beta=1}^b \bigotimes_{y=1}^n [G]_{(\text{row}(\beta,x),y)}^{\mathcal{X}_\beta \times \{y\}}$ for every $G \in \mathcal{G}$ and $\bigotimes_{\beta=1}^b \bigotimes_{y=1}^n C_{(\text{row}(\beta,x),y),(\text{row}(\beta,x'),y)}^{\mathcal{X}_\beta \times \{y\}}$ respectively. We prove this formally in Lemma 2.

Now the non-Clifford gate T can be implemented using via gate teleportation [38, 39]. Without a controlled quantum operation dependent on the output of a Z -measurement, the correct output is obtained with a probability of one half using the quantum circuits below. In the standard single qubit gate teleportation protocol, the Z -measurement is performed on the data qubit, so to allow the measurement to be performed on the ancilla qubit, we can just swap the qubit back, which yields the second circuit below. Now the logical CNOT and the logical Z for our quantum code can be applied transversally. Hence the gate teleportation of the logical T operation which relies on these logical operations can also be performed transversally. All that is required for the correct implementation of the gate teleportation of the logical T -gate is that the outcome of the logical Z -measurement is 1. We note that the required measurement can be deferred until decryption due to the principle of deferred measurement [40].

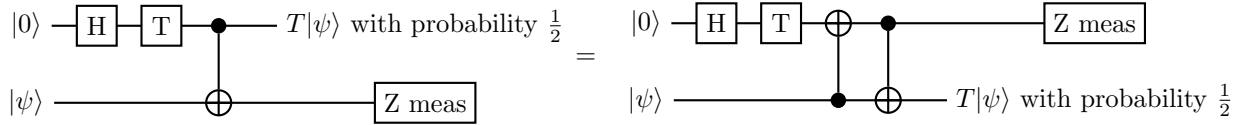

Lemma 2. Let $\gamma = (b, r, t, n, m)$ be a 5-tuple of positive integers satisfying the constraints as given in Theorem 1. Let $\kappa \in S_{n+m}$, τ be given by (6), and $(V_1, \dots, V_d) \in L(\mathcal{H}^{r,1})^d$ be a sequence of r -qubit unitary matrices, where every V_i is either from the set \mathcal{G} , a two-qubit CNOT, or a single-qubit T gate. Let $(\rho_{\text{output}}, f) = \text{Dec}_\gamma(\kappa, \text{Eval}_\gamma((V_1, \dots, V_d), \text{Enc}_\gamma(\kappa, \tau)))$ be the output of the decryption algorithm as given in Cryptosystem 1 If $f = 1$, then

$$\rho_{\text{output}} = V_d \dots V_1 \rho_{\text{input}} V_1^\dagger \dots V_d^\dagger.$$

Proof. For any subset \mathcal{I} of $[n+m]$, let $\kappa(\mathcal{I}) = \{\kappa(k) : k \in \mathcal{I}\}$. Let $\mathcal{L}_\kappa = [b(r+t)] \times \mathcal{Y}_\kappa$ and let $\bar{\mathcal{L}}_\kappa = [b(r+t)] \times \bar{\mathcal{Y}}_\kappa$. Note that for every $\tau \in D(\mathcal{H}^{b(r+t),1})$, we necessarily have $\text{Enc}_\gamma(\kappa, \tau) = \rho_{\text{code}} \otimes \rho_{\text{anc}}$, where $\rho_{\text{code}} \in D(\mathcal{H}^{\mathcal{L}_\kappa})$ and $\rho_{\text{anc}} = [I]_{\bar{\mathcal{L}}_\kappa} 2^{-b(r+t)m}$ denotes the maximally mixed state on the ancilla qubits. Let $\mathbb{1}_{\text{anc}}^\kappa = [I]_{\mathcal{L}_\kappa}$ and $\mathbb{1}_{\text{anc}} = [I]_{[b(r+t)] \times [n+1:n+m]}$ denote the identity operator over the encrypted and unencrypted ancilla qubits respectively. Note that for all unitary matrices R and R' in $L(\mathcal{H}^{\mathcal{L}_\kappa})$ and $L(\mathcal{H}^{\bar{\mathcal{L}}_\kappa})$ respectively, and for any $\rho_{\text{code}} \in D(\mathcal{H}^{\mathcal{L}_\kappa})$, we have

$$(R \otimes R')(\rho_{\text{code}} \otimes \rho_{\text{anc}})(R \otimes R')^\dagger = (R \rho_{\text{code}} R^\dagger) \otimes \rho_{\text{anc}}, \quad (25)$$

It follows from (20) that for all distinct z and z' in $[r+t]$ we have

$$G_z^{\text{Eval}}(\rho_{\text{code}} \otimes \rho_{\text{anc}})(G_z^{\text{Eval}})^\dagger = (G_z^{\text{code},\kappa} \rho_{\text{code}} (G_z^{\text{code},\kappa})^\dagger) \otimes \rho_{\text{anc}}, \quad (26)$$

and

$$C_{z,z'}^{\text{Eval}}(\rho_{\text{code}} \otimes \rho_{\text{anc}})(C_{z,z'}^{\text{Eval}})^\dagger = (C_{z,z'}^{\text{code},\kappa} \rho_{\text{code}} (C_{z,z'}^{\text{code},\kappa})^\dagger) \otimes \rho_{\text{anc}}. \quad (27)$$

For all $i \in [d]$, let $\alpha(i)$ be the number of T gates in the sequence (V_1, \dots, V_i) . From Cryptosystem 1, the evaluation unitaries $V_1^{\text{Eval}}, \dots, V_d^{\text{Eval}}$ have the form

$$V_i^{\text{Eval}} = \begin{cases} G_z^{\text{Eval}} & , V_i = [G]_{(z,1)}^{r,1} \text{ for some } G \in \{X, Y, Z, H, S\} \text{ and } z \in [r] \\ C_{z,z'}^{\text{Eval}} & , V_i = C_{z,z'}^{r,1} \text{ for some } z, z' \in [r] \text{ where } z \neq z' \\ C_{r+\alpha(i),z}^{\text{Eval}} & , V_i = [T]_{(z,1)}^{r,1} \text{ for some } z \in [r] \end{cases}. \quad (28)$$

Now define V_i^{code} and V_i^{anc} where

$$V_i^{\text{code},\kappa} = \begin{cases} G_z^{\text{code},\kappa} & , V_i = [G]_{(z,1)}^{r,1} \text{ for some } G \in \{X, Y, Z, H, S\} \text{ and } z \in [r] \\ C_{z,z'}^{\text{code},\kappa} & , V_i = C_{z,z'}^{r,1} \text{ for some } z, z' \in [r] \text{ where } z \neq z' \\ C_{r+\alpha(i),z}^{\text{code},\kappa} & , V_i = [T]_{(z,1)}^{r,1} \text{ for some } z \in [r] \end{cases}, \quad (29)$$

and

$$V_i^{\text{anc},\kappa} = \begin{cases} G_z^{\text{anc},\kappa} & , V_i = [G]_{(z,1)}^{r,1} \text{ for some } G \in \{X, Y, Z, H, S\} \text{ and } z \in [r] \\ C_{z,z'}^{\text{anc},\kappa} & , V_i = C_{z,z'}^{r,1} \text{ for some } z, z' \in [r] \text{ where } z \neq z' \\ C_{r+\alpha(i),z}^{\text{anc},\kappa} & , V_i = [T]_{(z,1)}^{r,1} \text{ for some } z \in [r] \end{cases}. \quad (30)$$

Hence for every $i \in [d]$,

$$V_i^{\text{Eval}} = V_i^{\text{code},\kappa} \otimes V_i^{\text{anc},\kappa}. \quad (31)$$

Since the encrypted columns of ancilla qubits give the identities (26) and (27), we have

$$V_d^{\text{Eval}} \dots V_1^{\text{Eval}} (\rho_{\text{code}} \otimes \rho_{\text{anc}}) (V_1^{\text{Eval}})^\dagger \dots (V_d^{\text{Eval}})^\dagger = (V_d^{\text{code},\kappa} \dots V_1^{\text{code},\kappa} \rho_{\text{code}} (V_1^{\text{code},\kappa})^\dagger \dots (V_d^{\text{code},\kappa})^\dagger) \otimes \rho_{\text{anc}}, \quad (32)$$

which implies that applying the unitary $V_d^{\text{Eval}} \dots V_1^{\text{Eval}}$ is equivalent to applying the unitary $(V_d^{\text{code},\kappa} \dots V_1^{\text{code},\kappa}) \otimes \mathbb{1}_{\text{anc}}^\kappa$. In the Heisenberg picture, the unpermuting of the columns of the qubits followed by implementing the quantum circuit U^\dagger maps the evaluation unitary $(V_d^{\text{code},\kappa} \dots V_1^{\text{code},\kappa}) \otimes \mathbb{1}_{\text{anc}}^\kappa$ to

$$U^\dagger P_\kappa^\dagger (V_d^{\text{code},\kappa} \dots V_1^{\text{code},\kappa} \otimes \mathbb{1}_{\text{anc}}^\kappa) P_\kappa U = (U^\dagger P_\kappa^\dagger (V_d^{\text{code},\kappa} \otimes \mathbb{1}_{\text{anc}}^\kappa) P_\kappa U) \dots (U^\dagger P_\kappa^\dagger (V_1^{\text{code},\kappa} \otimes \mathbb{1}_{\text{anc}}^\kappa) P_\kappa U), \quad (33)$$

where $P_\kappa = \varphi_{b(r+t),n+m}(\kappa)$. Now define the decrypted unitary operations

$$V_i^{\text{code}} = \begin{cases} G_z^{\text{code}} & , V_i = [G]_{(z,1)}^{r,1} \text{ for some } G \in \{X, Y, Z, H, S\} \text{ and } z \in [r] \\ C_{z,z'}^{\text{code}} & , V_i = C_{z,z'}^{r,1} \text{ for some } z, z' \in [r] \text{ where } z \neq z' \\ C_{r+\alpha(i),z}^{\text{code}} & , V_i = [T]_{(z,1)}^{r,1} \text{ for some } z \in [r] \end{cases}. \quad (34)$$

Clearly for every $i \in [d]$,

$$P_\kappa^\dagger (V_i^{\text{code},\kappa} \otimes \mathbb{1}_{\text{anc}}^\kappa) P_\kappa = V_i^{\text{code}} \otimes \mathbb{1}_{\text{anc}}.$$

Now define $\mathbb{1}_{\beta,z}$ to be the identity operator on the first n columns of every qubit in the β -th copy, except for the row with label $\text{row}(\beta, z)$. Similarly define $\mathbb{1}_{\beta,(z,z')}$ to be the identity operator on the first n columns of every qubit in the β -th copy, except for the rows with labels $\text{row}(\beta, z)$ and $\text{row}(\beta, z')$. Then we have the block decompositions

$$G_z^{\text{code}} = \bigotimes_{\beta=1}^b G_z^{\text{code},\beta}, \quad C_{z,z'}^{\text{code}} = \bigotimes_{\beta=1}^b C_{z,z'}^{\text{code},\beta}, \quad (35)$$

where for each $\beta \in [b]$ we can write

$$G_z^{\text{code},\beta} = \overline{G}_{\text{row}(\beta,z)} \otimes \mathbb{1}_{\beta,z}, \quad (36)$$

and

$$C_{z,z'}^{\text{code},\beta} = \overline{C}_{\text{row}(\beta,z),\text{row}(\beta,z')} \otimes \mathbb{1}_{\beta,(z,z')}. \quad (37)$$

Observe now that we have the following cases.

1. Case $V_i = [G]_{(z,1)}^{r,1}$ for some $G \in \{X, Y, Z, H, S\}$ and $z \in [r]$.
Observe that

$$\begin{aligned} U^\dagger (V_i^{\text{code}} \otimes \mathbb{1}_{\text{anc}}) U &= \left(\bigotimes_{\beta=1}^b \left(U_{\text{row}(\beta,z)}^\dagger \overline{G}_{\text{row}(\beta,z)} U_{\text{row}(\beta,z)} \otimes \mathbb{1}_{\beta,z} \right) \right) \otimes \mathbb{1}_{\text{anc}} = \left(\bigotimes_{\beta=1}^b [G]_{(\text{row}(\beta,z),1)}^{\mathcal{X}_\beta \times [n]} \right) \otimes \mathbb{1}_{\text{anc}} \\ &= \left(\bigotimes_{\beta=1}^b V_i \otimes [I]^{\mathcal{X}_\beta \times [2:n]} \right) \otimes \mathbb{1}_{\text{anc}}. \end{aligned} \quad (38)$$

2. Case $V_i = C_{z,z'}^{r,1}$ for some $z, z' \in [r]$ where $z \neq z'$.
Observe that

$$\begin{aligned}
U^\dagger(V_i^{\text{code}} \otimes \mathbb{1}_{\text{anc}})U &= \left(\bigotimes_{\beta=1}^b \left((U_{\text{row}(\beta,z)}^\dagger \otimes U_{\text{row}(\beta,z')}^\dagger) \overline{C}_{\text{row}(\beta,z), \text{row}(\beta,z')} (U_{\text{row}(\beta,z)} \otimes U_{\text{row}(\beta,z')}) \otimes \mathbb{1}_{\beta,(z,z')} \right) \right) \otimes \mathbb{1}_{\text{anc}} \\
&= \left(\bigotimes_{\beta=1}^b C_{(\text{row}(\beta,z),1), (\text{row}(\beta,z'),1)}^{\mathcal{X}_\beta \times [n]} \right) \otimes \mathbb{1}_{\text{anc}} \\
&= \left(\bigotimes_{\beta=1}^b V_i \otimes [I]^{\mathcal{X}_\beta \times [2:n]} \right) \otimes \mathbb{1}_{\text{anc}}. \tag{39}
\end{aligned}$$

3. Case $V_i = [T]_{(z,1)}^{r,1}$ for some $z \in [r]$.

From the above two cases, it follows that

$$U^\dagger(V_i^{\text{code}} \otimes \mathbb{1}_{\text{anc}})U = \left(\bigotimes_{\beta=1}^b C_{(\text{row}(\beta, r+\alpha(i)),1), (\text{row}(\beta,z),1)}^{\mathcal{X}_\beta \times [n]} C_{(\text{row}(\beta,z),1), (\text{row}(\beta, r+\alpha(i)),1)}^{\mathcal{X}_\beta \times [n]} \right) \otimes \mathbb{1}_{\text{anc}}. \tag{40}$$

Hence $U^\dagger P_\kappa^\dagger(V_i^{\text{code}, \kappa} \otimes \mathbb{1}_{\text{anc}}^\kappa) P_\kappa U$ implements the correct decrypted Clifford operations. Subsequent measurement of the qubits with the observable Z in the first column in the rows $\mathcal{X}_{\text{magic}}$ then completes the evaluation of the T gate teleportation. The copy \mathcal{X}_β with every observable measured being +1 then implements all the T gates correctly, and hence that copy contains the correct quantum output $\rho_{\text{output}} = V_d \dots V_1 \rho_{\text{input}} V_1 \dots V_d$. \square

Broadbent and Jeffery also require that a quantum *fully* homomorphic encryption satisfies two properties: correctness and compactness. Perfect correctness occurs when the evaluated output on the cipherstate after decryption is exactly the correct evaluated input. For all $n-1$ divisible by 4, whenever Cryptosystem 1 yields a success flag $f=1$, the corresponding ρ_{out} satisfies perfect correctness because $\rho_{\text{out}} = V \rho V^\dagger$, independent of the quantum circuit V . This is because each Clifford gate is implemented perfectly within our scheme, and the decryption algorithm outputs the copy with the correct T gates implemented when $f=1$. Thus although Cryptosystem 1 does not succeed in implementing T gates with unit probability, it can be said to have *heralded* perfect completeness: provided $f=1$ the correct unitary has been implemented. For constant t , the number of copies b need only be a large constant as given by Lemma 3 in order to have a high probability of implementing the correct circuit. We emphasize that with even a single copy, we have constant probability of success; we simply use extra copies to amplify the probability of success.

Lemma 3. *Let $n-1$ be divisible by 4. For all positive integers t and all positive δ such that $0 < \delta < 1$, let $b \geq (\sqrt{\frac{-\ln \delta}{2}} + 1)^2 2^{2t}$. Then the probability of at least one of the b copies implementing the correct quantum circuit is at least $1 - \delta$.*

Proof. Without loss of generality we consider $t \geq 1$, since when $t=0$ the probability of obtaining the correct circuit is trivially unity. Let $c = -\ln \delta$. Since $b \geq 1$, we get the inequality $2^{-t} \geq \sqrt{\frac{c}{2b}} + \frac{1}{\sqrt{b}} \geq \sqrt{\frac{c}{2b}} + \frac{1}{b}$. For each copy, the probability of success is exactly 2^{-t} , since the probability of implementing each T -gate successfully is $\frac{1}{2}$.

For $\beta \in [b]$ let X_β be a Bernoulli random variable such that $\Pr[X_\beta = 0] = 2^{-t}$ and $\Pr[X_\beta = 1] = 1 - 2^{-t}$, so that $X_\beta = 1$ indicates a failure to implement t single qubit T gates successfully. Then the probability of at least $b-1$ failures is

$$\delta' = \Pr\left[\sum_{\beta=1}^b X_\beta \geq b-1\right] \leq \exp\left(-\frac{2((b-1) - b(1-2^{-t}))^2}{b}\right), \tag{41}$$

where the inequality follows from Hoeffding's bound [41]. Now $((b-1) - b(1-2^{-t}))^2 = (b-1-b+2^{-t}b)^2 = f(2^{-t})$ where $f(x) = (bx-1)^2$. Denoting $f'(x) = \frac{d}{dx} f(x)$, observe that for all $x > 1/b$, $f'(x) = 2b^2x - 2b > 0$. This implies that $f(x)$ is a strictly increasing function on the open interval $(1/b, \infty)$. Now $0 < \delta < 1$ implies that $c > 0$, which in turn implies that $b > 2^t$ and $2^{-t} > 1/b$. Hence we get $f(2^{-t}) > f(\sqrt{\frac{c}{2b}} + \frac{1}{b}) = \frac{bc}{2}$. It follows that $\delta' \leq \exp(-c) = \delta$. \square

The definition of compactness follows analogously from its classical counterpart. It requires that the complexity of Dec_γ be independent of the evaluated circuit. Our QHE scheme satisfies the compactness requirement if the circuit contains a constant number of T gates. In the three-part algorithm for Dec_γ , U^\dagger requires $2(n-1)b(r+t)$ gates, and P_κ^\dagger requires at most $(n+m-1)b(r+t)$ gates (the largest cycle contained in any element of S_{m+n} is a $(m+n)$ -cycle which can be written as a product of $m+n-1$ swaps). The remainder of Dec_γ involves a readout of Z measurements and discarding a subsystem. Since t is constant, b is also constant, and the total number of gates required for decryption is independent of d , the size of the circuit to be evaluated. Hence, our scheme is compact for circuits with a constant maximum number of T gates and unbounded Clifford gates.

Randomly permuting the columns of qubits obfuscates the subset of columns where the quantum information resides, thereby encrypting the quantum data. This results in the trace distance between any two outputs being exponentially small, which we quantify and prove in Lemma 4. Indeed Lemma 4 implies that our scheme has $(0, 2\epsilon)$ -indistinguishability, where ϵ is given in our Theorem 1, which is equivalent to strong $(1, 8\epsilon)$ -entropic security by Definition 4 and Theorem 3 of [42]. This notion of security for quantum encryption is stronger than that of security under chosen plaintext attacks where the adversary uses only classical inputs, as used in [36].

Lemma 4. *Let $n, m, p \in \mathbb{Z}_+$ and $q = n + m$. Let $U = \bigotimes_{x=1}^p U_x \otimes [I]^{[p] \times [n+1:q]}$ where U_x is defined in (9). Also let \mathcal{E} be a quantum channel as defined in (8). For all $\Psi, \Psi' \in D(\mathcal{H}^{p,1})$, let $\rho = U\mathcal{E}(\Psi)U^\dagger$ and $\rho' = U\mathcal{E}(\Psi')U^\dagger$. Let $\tilde{\rho} = \frac{1}{q!} \sum_{P \in \varphi_{p,q}(S_q)} P\rho P^\dagger$ and $\tilde{\rho}' = \frac{1}{q!} \sum_{P \in \varphi_{p,q}(S_q)} P\rho' P^\dagger$. Then*

$$\|\tilde{\rho} - \tilde{\rho}'\|_{\text{tr}} \leq 2(4^p - 1) \binom{n+m}{n}^{-1/2}. \quad (42)$$

Proof. Note that $\|\tilde{\rho} - \tilde{\rho}'\|_{\text{tr}} = \text{Tr}(M(\tilde{\rho} - \tilde{\rho}'))$ for some optimal Hermitian M diagonal in the same basis as $\tilde{\rho} - \tilde{\rho}'$, with eigenvalues equal to $+1$ or -1 . More precisely, if $\tilde{\rho} - \tilde{\rho}'$ has the spectral decomposition $\sum_i \lambda_i |i\rangle\langle i|$, then $M = \sum_i \text{sign}(\lambda_i) |i\rangle\langle i|$, where $\text{sign}(\lambda_i) = 1$ if $\lambda_i \geq 0$ and $\text{sign}(\lambda_i) = -1$ otherwise.

Given any $A \in \mathcal{M}_{p,q}$, define the set $S_A = \{\sigma = P\sigma_A P^\dagger : P \in \varphi_{p,q}(S_q)\}$ and the corresponding symmetric sum of σ_A as $\tilde{\sigma}_A = \sum_{\tau \in S_A} \tau$. Now denote Ω^* as the set of all non-zero vectors in $\mathcal{M}_{p,1}$. For all $\mathbf{v} \in \Omega^*$, we can have $\mathbf{v}[\mathbf{1}_n \mathbf{0}_m] \in \mathcal{S}$, where \mathcal{S} is some maximal subset of $\mathcal{M}_{p,q}$ such that for every $A, B \in \mathcal{S}$, $\tilde{\sigma}_A \neq \tilde{\sigma}_B$. Let $\tilde{M} = \frac{1}{q!} \sum_{P \in \varphi_{p,q}(S_q)} P M P^\dagger$. Then we can write $\tilde{M} = \sum_{A \in \mathcal{S}} a_A \tilde{\sigma}_A$, for appropriate real constants a_A .

Linearity and cyclicity of the trace give $\text{Tr}(M(\tilde{\rho} - \tilde{\rho}')) = \text{Tr}(\tilde{M}(\rho - \rho'))$. Note that $\rho - \rho'$ admits a decomposition

$$\rho - \rho' = \sum_{\substack{\mathbf{v} \in \Omega^* \\ A = \mathbf{v}[\mathbf{1}_n \mathbf{0}_m]}} \frac{r_{\mathbf{v}} - r'_{\mathbf{v}}}{2^{pq}} \sigma_A, \quad (43)$$

for appropriate real constants $r_{\mathbf{v}}$ and $r'_{\mathbf{v}}$. Using this decomposition of $\rho - \rho'$, the decomposition of \tilde{M} , the linearity of trace, and the triangle inequality, we get

$$\|\tilde{\rho} - \tilde{\rho}'\|_{\text{tr}} \leq \sum_{\substack{\mathbf{v} \in \Omega^* \\ A = \mathbf{v}[\mathbf{1}_n \mathbf{0}_m] \\ B \in \mathcal{S}}} |\text{Tr} a_B \tilde{\sigma}_B \frac{(r_{\mathbf{v}} - r'_{\mathbf{v}})}{2^{pq}} \sigma_A|. \quad (44)$$

By orthogonality of the Pauli operators under the Hilbert-Schmidt inner product, we get

$$\|\tilde{\rho} - \tilde{\rho}'\|_{\text{tr}} \leq \sum_{\substack{\mathbf{v} \in \Omega^* \\ A = \mathbf{v}[\mathbf{1}_n \mathbf{0}_m]}} |\text{Tr} a_A \tilde{\sigma}_A \frac{(r_{\mathbf{v}} - r'_{\mathbf{v}})}{2^{pq}} \sigma_A|. \quad (45)$$

Since \tilde{M} has eigenvalues with absolute value at most one, for any density matrix $\omega \in D(\mathcal{H}^{p,q})$, we must have $|\text{Tr} M\omega| \leq 1$. Hence it trivially follows that $|r_{\mathbf{v}}|$ and $|r'_{\mathbf{v}}|$ are both at most 1. It remains to obtain upper bounds on some of the $|a_A|$, the absolute values of the coefficients of the symmetric Pauli decomposition of \tilde{M} . Moreover, $\text{Tr}(\tilde{M}^2) \leq 2^{pq}$, which implies that for every $\mathbf{v} \in \Omega^*$,

$$\begin{aligned} 2^{pq} &\geq \text{Tr}(\tilde{M}^2) = \text{Tr}\left(\sum_{A, A' \in \mathcal{S}} a_A a_{A'} \tilde{\sigma}_A \tilde{\sigma}_{A'}\right) = \text{Tr}\left(\sum_{A \in \mathcal{S}} a_A^2 \tilde{\sigma}_A^2\right) \\ &\geq \text{Tr}(a_{\mathbf{v}[\mathbf{1}_n \mathbf{0}_m]}^2 \tilde{\sigma}_{\mathbf{v}[\mathbf{1}_n \mathbf{0}_m]}^2) = a_{\mathbf{v}[\mathbf{1}_n \mathbf{0}_m]}^2 \binom{n+m}{m} 2^{pq}. \end{aligned} \quad (46)$$

This implies that $|a_{\mathbf{v}[\mathbf{1}_n \mathbf{0}_m]}| \leq \binom{n+m}{m}^{-1/2}$. Now $|\Omega^*| = 4^p - 1$, and the result follows from (45). \square

Cryptosystem 1 provides the four algorithms necessary to qualify as a symmetric-key quantum homomorphic encryption scheme and provides compact encoding and decoding algorithms, and hence in order to prove Theorem 1, it suffices to prove the completeness and security properties. The completeness property follows directly from Lemma 2 and Lemma 3.

To see how the security property follows from Lemma 4, first note that for every positive integer N , we have

$$\sqrt{2\pi}N^{N+\frac{1}{2}}e^{-N} \leq N! \leq eN^{N+\frac{1}{2}}e^{-N}. \quad (47)$$

From this, for $m = \alpha n$, we get

$$\begin{aligned} \binom{n+m}{m} &\geq \frac{\sqrt{2\pi}(n+m)^{n+m+\frac{1}{2}}}{e^2 n^{n+\frac{1}{2}} m^{m+\frac{1}{2}}} \\ &= \frac{\sqrt{2\pi}(1+\alpha)^{n(1+\alpha)+\frac{1}{2}} n^{n(1+\alpha)+\frac{1}{2}}}{e^2 n^{n+\frac{1}{2}} \alpha^{\alpha n+\frac{1}{2}} n^{\alpha n+\frac{1}{2}}} \\ &= \frac{1}{e^2} \sqrt{\frac{2\pi(1+\alpha)}{n\alpha}} \frac{(1+\alpha)^{n(1+\alpha)}}{\alpha^{\alpha n}} \\ &= \frac{1}{e^2} \sqrt{\frac{2\pi(\frac{1}{\alpha}+1)}{n}} (1+\alpha)^n \left(\frac{1}{\alpha}+1\right)^{\alpha n} \end{aligned} \quad (48)$$

Hence

$$\begin{aligned} 2(4^{b(r+t)} - 1) \binom{n+m}{m}^{-1/2} &\leq 4^{b(r+t)} (2e) \left(\frac{n}{2\pi(\frac{1}{\alpha}+1)}\right)^{1/4} (1+\alpha)^{-n/2} \left(\frac{1}{\alpha}+1\right)^{-m/2} \\ &= 4^{b(r+t)} e \left(\frac{8n}{\pi(1+\frac{1}{\alpha})}\right)^{1/4} \exp\left(-\frac{n}{2} \ln(1+\alpha) - \frac{m}{2} \ln\left(1+\frac{1}{\alpha}\right)\right), \end{aligned} \quad (49)$$

and the security result follows.

V. OPEN QUESTIONS

This work has shown that it is possible to construct quantum cryptosystems which allows for evaluation of circuits containing a constant number of non-Clifford gates with entropic security. This can be seen as a significant strengthening of the results of Broadbent and Jeffery [36], who introduced a scheme with privacy homomorphisms of quantum circuits with a constant T -depth which is secure under the same computational assumptions as classical FHE schemes. Indeed, the scheme of Broadbent and Jeffery can be information-theoretically secure by substituting the classical homomorphic encryption algorithm that they use for the Clifford gate computation with our scheme; however this would violate their compactness requirement. Moreover, our scheme trivially allows privacy homomorphisms of arbitrary reversible linear boolean circuits using the privacy homomorphisms of CNOT and X gates.

This opens the door to several questions:

1. First and foremost, is the question of whether quantum mechanics allows for unconditionally secure fully-homomorphic encryption. In the classical world, homomorphic encryption schemes for fixed depth circuits [43] foreshadowed the discovery of the first fully-homomorphic encryption scheme. Importantly, this scheme [27] made use of homomorphic encryption for fixed depth circuits in a fundamental way. The results presented in the current manuscript motivate the search for a quantum analogue of the bootstrapping approach used so successfully in [27]. This question can also be posed in a weakened form, to ask whether quantum fully-homomorphic encryption is possible under plausible security assumptions.
2. A possible limiting factor to the search for a quantum FHE scheme is the existence of the no-go result of [37]. This result precludes fully-homomorphic encryption schemes, and indeed efficient homomorphic encryption schemes of any sort for which the cardinality of the set of homomorphisms is more than exponentially large, for which the accessible information from the ciphertext is exactly zero. The question then arises as to whether if this is requirement for zero accessible information is relaxed to allow up to exponentially small information (as in the present work), whether this no-go result still holds. We note that neither the results presented here, nor those presented in [36] present a counter-example to this conjecture, since the set of possible privacy homomorphisms

has only exponential cardinality. The current best known bound on this is given by [35], which allows for a set of privacy homomorphisms which has greater than exponential cardinality. However, in that case, the accessible information scaled as a constant fraction of the encoded information. It remains an open question whether improvements can be made in either direction.

VI. ACKNOWLEDGEMENTS

The authors thank Anne Broadbent and Stacey Jeffery for useful correspondence about quantum homomorphic encryption. JF also thanks Renato Renner for useful discussions relating to security definitions. The authors acknowledge support from Singapore’s National Research Foundation and Ministry of Education. This material is based on research funded by the Singapore National Research Foundation under NRF Award NRF-NRFF2013-01.

-
- [1] C. H. Bennett and G. Brassard, “Quantum cryptography: Public key distribution and coin tossing,” in *Proceedings of IEEE International Conference on Computers, Systems and Signal Processing*, vol. 175, New York, 1984.
 - [2] A. K. Ekert, “Quantum cryptography based on Bell’s theorem,” *Phys. Rev. Lett.*, vol. 67, pp. 661–663, Aug 1991.
 - [3] S. Pironio, A. Acín, S. Massar, A. B. de la Giroday, D. N. Matsukevich, P. Maunz, S. Olmschenk, D. Hayes, L. Luo, T. A. Manning, and C. Monroe, “Random numbers certified by Bell’s theorem,” *Nature*, vol. 464, no. 7291, pp. 1022–1024, 2010.
 - [4] U. Vazirani and T. Vidick, “Certifiable quantum dice: or, true random number generation secure against quantum adversaries,” in *Proceedings of the forty-fourth annual ACM symposium on Theory of computing*, pp. 61–76, ACM, 2012.
 - [5] L. Goldenberg, L. Vaidman, and S. Wiesner, “Quantum gambling,” *Phys. Rev. Lett.*, vol. 82, pp. 3356–3359, Apr 1999.
 - [6] D. Aharonov, A. Ta-Shma, U. V. Vazirani, and A. C. Yao, “Quantum bit escrow,” in *Proceedings of the Thirty-second Annual ACM Symposium on Theory of Computing*, STOC, (New York, NY, USA), pp. 705–714, ACM, 2000.
 - [7] A. Ambainis, “A new protocol and lower bounds for quantum coin flipping,” in *Proceedings of the Thirty-third Annual ACM Symposium on Theory of Computing*, STOC ’01, (New York, NY, USA), pp. 134–142, ACM, 2001.
 - [8] M. Hillery, V. Bužek, and A. Berthiaume, “Quantum secret sharing,” *Phys. Rev. A*, vol. 59, pp. 1829–1834, Mar 1999.
 - [9] R. Cleve, D. Gottesman, and H.-K. Lo, “How to share a quantum secret,” *Phys. Rev. Lett.*, vol. 83, pp. 648–651, Jul 1999.
 - [10] D. Gottesman, “Theory of quantum secret sharing,” *Phys. Rev. A*, vol. 61, p. 042311, Mar 2000.
 - [11] G. M. D’Ariano, D. Kretschmann, D. Schlingemann, and R. F. Werner, “Reexamination of quantum bit commitment: The possible and the impossible,” *Phys. Rev. A*, vol. 76, p. 032328, Sep 2007.
 - [12] A. Chailloux and I. Kerenidis, “Optimal bounds for quantum bit commitment,” in *Foundations of Computer Science (FOCS), 2011 IEEE 52nd Annual Symposium on*, pp. 354–362, Oct 2011.
 - [13] A. Kent, “Unconditionally secure bit commitment with flying qubits,” *New Journal of Physics*, vol. 13, no. 11, p. 113015, 2011.
 - [14] A. Kent, “Unconditionally secure bit commitment by transmitting measurement outcomes,” *Physical review letters*, vol. 109, no. 13, p. 130501, 2012.
 - [15] V. Dunjko, J. F. Fitzsimons, C. Portmann, and R. Renner, “Composable security of delegated quantum computation,” in *Advances in Cryptology—ASIACRYPT 2014*, pp. 406–425, Springer, 2014.
 - [16] A. Broadbent, J. Fitzsimons, and E. Kashefi, “Universal blind quantum computation,” in *Foundations of Computer Science, 2009. FOCS ’09. 50th Annual IEEE Symposium on*, pp. 517–526, Oct 2009.
 - [17] D. Aharonov, M. Ben-or, and E. Eban, “Interactive proofs for quantum computations,” *arXiv:0810.5375*, 2008.
 - [18] S. Barz, E. Kashefi, A. Broadbent, J. F. Fitzsimons, A. Zeilinger, and P. Walther, “Demonstration of blind quantum computing,” *Science*, vol. 335, no. 6066, pp. 303–308, 2012.
 - [19] T. Morimae and K. Fujii, “Blind quantum computation protocol in which Alice only makes measurements,” *Phys. Rev. A*, vol. 87, p. 050301, May 2013.
 - [20] V. Giovannetti, L. Maccone, T. Morimae, and T. G. Rudolph, “Efficient universal blind quantum computation,” *Phys. Rev. Lett.*, vol. 111, p. 230501, Dec 2013.
 - [21] A. Mantri, C. A. Pérez-Delgado, and J. F. Fitzsimons, “Optimal blind quantum computation,” *Phys. Rev. Lett.*, vol. 111, no. 23, p. 230502, 2013.
 - [22] J. F. Fitzsimons and E. Kashefi, “Unconditionally verifiable blind computation,” *arXiv preprint arXiv:1203.5217*, 2013.
 - [23] B. W. Reichardt, F. Unger, and U. Vazirani, “Classical command of quantum systems,” *Nature*, vol. 496, pp. 456–460, 04 2013.
 - [24] S. Barz, J. F. Fitzsimons, E. Kashefi, and P. Walther, “Experimental verification of quantum computation,” *Nat. Phys.*, vol. 9, pp. 727–731, 11 2013.
 - [25] M. McKague, “Self-testing graph states,” in *Theory of Quantum Computation, Communication, and Cryptography* (D. Bacon, M. Martin-Delgado, and M. Roetteler, eds.), vol. 6745 of *Lecture Notes in Computer Science*, pp. 104–120, Springer Berlin Heidelberg, 2014.
 - [26] R. L. Rivest, L. Adleman, and M. L. Dertouzos, “On data banks and privacy homomorphisms,” *Foundations of secure computation*, vol. 4, no. 11, pp. 169–180, 1978.

- [27] C. Gentry, “Fully homomorphic encryption using ideal lattices,” in *Proceedings of the Forty-first Annual ACM Symposium on Theory of Computing*, STOC '09, (New York, NY, USA), pp. 169–178, ACM, 2009.
- [28] M. Van Dijk, C. Gentry, S. Halevi, and V. Vaikuntanathan, “Fully homomorphic encryption over the integers,” in *Advances in cryptology—EUROCRYPT 2010*, pp. 24–43, Springer, 2010.
- [29] C. Gentry, S. Halevi, and N. Smart, “Fully homomorphic encryption with polylog overhead,” in *Advances in Cryptology EUROCRYPT 2012* (D. Pointcheval and T. Johansson, eds.), vol. 7237 of *Lecture Notes in Computer Science*, pp. 465–482, Springer Berlin Heidelberg, 2012.
- [30] M. Liang, “Symmetric quantum fully homomorphic encryption with perfect security,” *Quantum Information Processing*, vol. 12, no. 12, pp. 3675–3687, 2013.
- [31] M. Liang, “Quantum fully homomorphic encryption scheme based on universal quantum circuit,” *Quantum Information Processing*, pp. 1–11, 2015.
- [32] K. A. G. Fisher, A. Broadbent, L. K. Shalm, Z. Yan, J. Lavoie, R. Prevedel, T. Jennewein, and K. J. Resch, “Quantum computing on encrypted data,” *Nat. Commun.*, vol. 5, 01 2014.
- [33] A. M. Childs, “Secure assisted quantum computation,” *Quantum Info. Comput.*, vol. 5, pp. 456–466, Sept. 2005.
- [34] P. P. Rohde, J. F. Fitzsimons, and A. Gilchrist, “Quantum walks with encrypted data,” *Phys. Rev. Lett.*, vol. 109, p. 150501, Oct 2012.
- [35] S.-H. Tan, J. A. Kettlewell, Y. Ouyang, L. Chen, and J. F. Fitzsimons, “A quantum approach to fully homomorphic encryption,” *arXiv preprint arXiv:1411.5254*, 2014.
- [36] A. Broadbent and S. Jeffery, “Quantum homomorphic encryption for circuits of low T -gate complexity,” *arXiv preprint arXiv:1412.8766*, 2014.
- [37] L. Yu, C. A. Pérez-Delgado, and J. F. Fitzsimons, “Limitations on information-theoretically-secure quantum homomorphic encryption,” *Phys. Rev. A*, vol. 90, p. 050303, Nov 2014.
- [38] D. Gottesman and I. L. Chuang, “Demonstrating the viability of universal quantum computation using teleportation and single-qubit operations,” *Nature*, vol. 402, pp. 390–393, 1999.
- [39] X. Zhou, D. W. Leung, and I. L. Chuang, “Methodology for quantum logic gate construction,” *Phys. Rev. A*, vol. 62, p. 052316, Oct 2000.
- [40] M. A. Nielsen and I. L. Chuang, *Quantum Computation and Quantum Information*. Cambridge University Press, second ed., 2000.
- [41] W. Hoeffding, “Probability inequalities for sums of bounded random variables,” *Amer. Stat. Assoc. J.*, vol. 58, pp. 13–30, 1963.
- [42] S. Desrosiers, “Entropic security in quantum cryptography,” *Quantum Information Processing*, vol. 8, no. 4, pp. 331–345, 2009.
- [43] D. Boneh, E.-J. Goh, and K. Nissim, “Evaluating 2-DNF formulas on ciphertexts,” in *Theory of Cryptography* (J. Kilian, ed.), vol. 3378 of *Lecture Notes in Computer Science*, pp. 325–341, Springer Berlin Heidelberg, 2005.
- [44] We note that since the Broadbent-Jeffrey cryptosystem utilises the classical FHE to compute sums of hidden subsets, it may be possible to remove the computational assumptions by replacing the FHE scheme with an information theoretically secure scheme which allows evaluation of only linear circuits. However, no analysis of such a modification has yet appeared in the literature.