

Linearly polarized remote-edge luminescence in GaSe nanoslabs

Yanhao Tang,¹ Wei Xie,¹ Krishna C. Mandal,² John A. McGuire,¹ and Chih-Wei Lai^{1,*}

¹*Department of Physics and Astronomy, Michigan State University, East Lansing, Michigan 48824*

²*Department of Electrical Engineering, University of South Carolina, Columbia, SC 29208, USA*

We report highly linearly polarized remote luminescence that emerges at the cleaved edges of nanoscale gallium selenide slabs tens of micrometers away from the optical excitation spot. The remote-edge luminescence (REL) measured in the reflection geometry has a degree of linear polarization above 0.90, with polarization orientation pointing toward the photoexcitation spot. The REL is dominated by an index-guided optical mode that is linearly polarized along the crystalline c -axis. This luminescence is from out-of-plane dipoles that are converted from in-plane dipoles through a spin-flip process at the excitation spot.

Two-dimensional layered materials present a new platform for integration of optoelectronic devices and nanoscale lasers^{1–4}. In this study, we exploit the anisotropic optical properties^{5–10} and unique optical selection rules^{11–13} in layered gallium selenide (GaSe) to generate highly linearly polarized luminescence at the remote cleaved edges of GaSe slabs of about 200 layers or more (Fig. 1a). The in-plane dipoles (d_{\perp}) generated at the photoexcited spot are converted to out-of-plane dipoles (d_{\parallel}) through a spin-flip process. Subsequent luminescence from d_{\parallel} propagates with wave vector orthogonal to the incident optical excitation beam through an index-guided optical mode that is linearly polarized along the crystalline c -axis. Remote luminescence emerges at the cleaved edges in the reflection geometry as a result of backscattering. This remote-edge luminescence (REL) has a degree of linear polarization above 0.90, with polarization orientation pointing toward the photoexcitation spot independent of the photoexcitation polarization. In contrast, the luminescence at the focal photoexcited spot (FL) is unpolarized under a linearly polarized optical excitation.

In most bulk semiconductors, the optical orientation and alignment of electron-hole (e - h) pairs and consequent polarized luminescence are limited¹⁴. In quasi-2D systems, such as semiconductor quantum wells, photoluminescence is typically unpolarized or circularly polarized, depending on the photoexcitation energy and polarization as well as the band structure. Highly linearly polarized luminescence or lasing has been observed in quasi-1D colloidal nanowires^{15–17} with strong dielectric confinement, as well as in quasi-0D quantum dots with a sizable anisotropy induced by strain or electron-hole exchange interactions^{18–21}. Recently, in 2D atomically thin transition metal dichalcogenides (TMDs), polarized luminescence has been shown to result from intra- and interlayer excitations²² or valley coherence^{23,24}. In 2D TMDs, though, the luminescence yield only becomes significant at the monolayer level when a crossover from indirect to direct gap occurs.

GaSe is a layered semiconductor characterized by covalently bound gallium and selenium atoms within a single layer and weak van der Waals-type interlayer interactions²⁵. The layers are stacked along the crystal-

lographic c -axis and form several polytypes with different stacking orders. The noncentrosymmetric ϵ -GaSe is the most widely studied monochalcogenide among the group-III monochalcogenides because of its high optical second-order nonlinearity^{25–27}. The *layered* structure of ϵ -GaSe results in highly anisotropic optical properties, as demonstrated by the distinct absorbance for light with $\vec{E} \perp c$ and $\vec{E} \parallel c$ ^{5–10}. Polarized spontaneous and stimulated emissions also occur near the quasi-direct gap ($E_g \sim 2$ eV) under optical excitation/detection at oblique angles^{28–36}. Nanoscale slabs of similar polar (pyroelectric) group-III monochalcogenide semiconductors have high optical nonlinearities and allow direct optical access for control of light-matter interactions and polarization properties, as well as index-guiding of light.

In this study, we investigate the spectral, *polarization*, and *dynamic* characteristics of the luminescence emanating at cleaved edges of GaSe slabs with a thickness d_L of 160 nm or more. The GaSe nanoslabs are mechanically exfoliated from a bulk ϵ -GaSe crystal³⁷ and deposited onto a Si substrate with a 90 nm SiO₂ layer. These GaSe dielectric slabs on SiO₂/Si form the simplest optical waveguides (Materials and Methods)³⁸. The thinnest GaSe that can sustain one guided transverse electric (TE) mode ($\vec{E} \perp c$) and transverse magnetic (TM) mode ($\vec{E} \parallel c$) for luminescence near the band edge (wavelength $\lambda \approx 600$ nm) is about 160 nm thick. The normally incident 2 ps optical excitation pulses create in-plane dipoles (d_{\perp}) that are rapidly converted to out-of-plane dipoles (d_{\parallel}) through spin-flip of electrons or holes (Fig. 1a)^{11–13}. The index-guided radiation from d_{\parallel} at the photoexcited spot propagates to the cleaved edges of the GaSe slabs. Under pulsed photoexcitation, the guided TM mode of d_{\parallel} luminescence dominates over the TE mode of d_{\perp} luminescence because the radiative recombination rate of d_{\parallel} is about 30 times higher than that of d_{\perp} . As a result, highly linearly polarized TM mode luminescence emerges in the reflection geometry at cleaved edges when backscattering is allowed in the presence of irregularities. We refer to such polarized remote luminescence at cleaved edges as remote-edge luminescence (REL). The REL typically has a degree of linear polarization $DoLP > 0.90$. Note that enhanced photoluminescence (PL) has also been observed at edges of

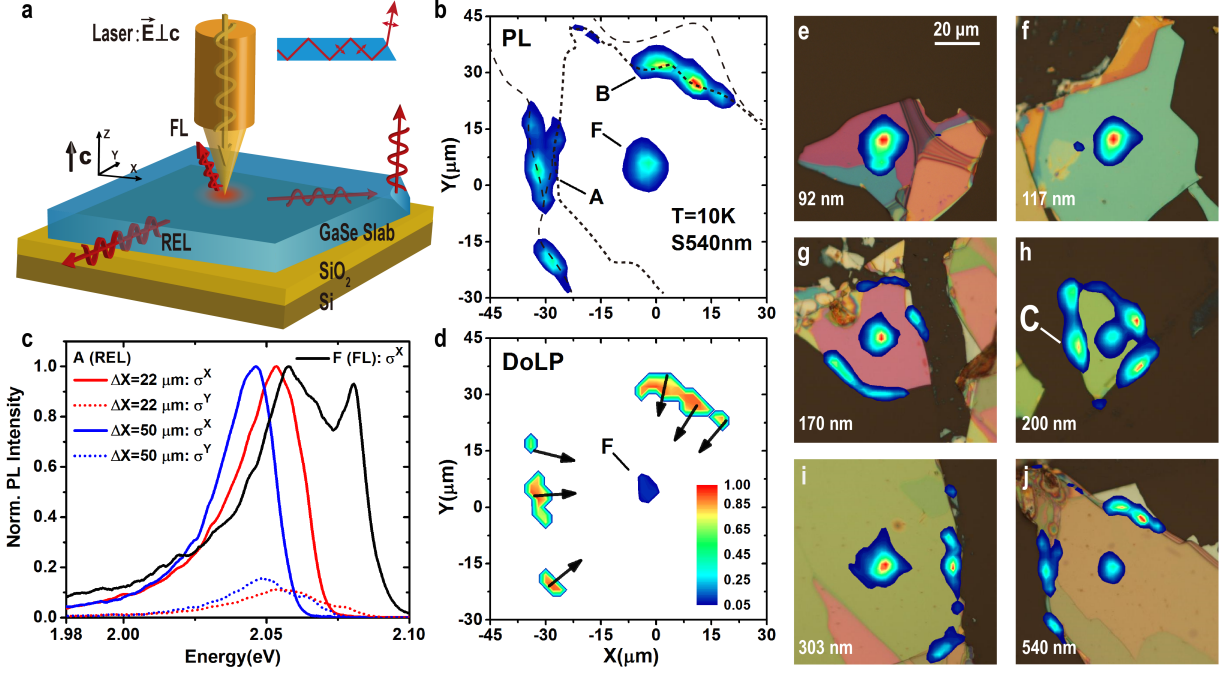

FIG. 1. (a) Schematic of the optical set-up. (b) Photoluminescence (PL) image of a 540 nm-thick GaSe slab at $T = 10$ K. The sample is optically pumped at the focal location F under a pump flux $P = 0.1 P_0$, where $P_0 = 2.6 \times 10^{14} \text{ cm}^{-2}$ per pulse. At P_0 , the photoexcited carrier density is about $3.4 \times 10^{17} \text{ cm}^{-3}$ ($2.7 \times 10^{10} \text{ cm}^{-2}$ per layer). The dashed lines represent the cleaved edges of the sample. Remote-edge luminescence (REL) emerges at the cleaved edges tens of micrometers away from the photoexcited spot. (c) Polarized spectra of the FL (black curve) from focal point F and the REL (red and blue curves) from location A with varying distances (ΔX) from the photoexcited spot for $P = 0.15 P_0$ at $T = 10$ K. The spectra are normalized with respect to the X-polarized (σ^X) component. Both σ^X (TM mode, solid lines) and σ^Y (TE mode, dashed lines) spectral components red-shift with respect to the FL with increasing ΔX as a result of anisotropic reabsorption. The anisotropic reabsorption also results in a decreasing spectrally integrated *DoLP* with increasing ΔX . The two peaks in the FL spectrum are attributed to free excitons (~ 2.08 eV) and exciton-carrier scattering (~ 2.06 eV), respectively. The FL is dominated by free excitons for $P \gtrsim 0.6 P_0$ (not shown). (d) Spatially resolved *DoLP* for $P = 0.1 P_0$. The false color and arrows represent the *DoLP* and polarization orientation, respectively. The measured maximal *DoLP* is about 0.93. Note that the REL at location A (Fig. 1c) is X-polarized, whereas the REL at location B is nearly Y-polarized. The REL has a polarization oriented toward the photoexcited spot. (e-j) Overlay of optical and luminescence images of samples with thickness $d_L = 92, 117, 170, 200$ (S200nm), 303, and 540 (S540nm). Luminescence images are measured at $T = 10$ K. The false colors in the luminescence images represent the relative intensities. The colors in the optical images are due to optical interference. The remote-edge luminescence (REL) is visible only for $d_L \gtrsim 160$ nm. The central elliptical luminescence spot is the focal photoexcited region. The REL is most prevalent in the 200 nm-thick sample in which single guided TE and TM modes are present.

WS_2 platelets where PL emanates from the *photoexcited spot*³⁹. In the experiments presented in this study, the in-plane (d_{\perp}) and out-of-plane (d_{\parallel}) dipoles are within the same layer, and the REL occurs tens of micrometers away from the photoexcited spot.

In Fig. 1, we study the spectral and polarization characteristics of the REL from a 540 nm-thick GaSe slab under excitation energy $E_p = 2.138$ eV at $T = 10$ K. Intense luminescence emerges at the cleaved edges of the GaSe slab even when the optical excitation spot is tens of micrometers away (Fig. 1b). Spectrally, the REL shows an apparent red shift compared with the luminescence at the focal photoexcited spot (FL). Additionally, the REL is highly linearly polarized ($DoCP \rightarrow 0.93$), whereas the FL is unpolarized under linearly polarized photoexcitation (Fig. 1d). Considering the REL as an

index-guided mode of luminescence originating from the photoexcited spot, one can attribute the spectral red-shift to anisotropic reabsorption³³ when luminescence propagates in-plane for a distance of tens of micrometers (Fig. 1c). However, for a 540 nm-thick GaSe dielectric slab on SiO_2 , about four guided TE modes and TM modes are allowed. In the presence of both TE and TM modes, the REL is expected to be unpolarized when the orientations of the photoexcited dipoles at the focal spot are random and isotropic. On the contrary, the measured luminescence polarization image (Fig. 1d) indicates that the polarization orientations of the REL point toward the photoexcited spot. Moreover, depending on the location and sample thickness, the intensity (emission flux) of the REL can exceed that of the FL (Fig. 1f-j). Such a polarization orientation pattern and intensity distribu-

tion suggest that the REL originates from out-of-plane dipoles (d_{\parallel}), with the electric field vector parallel to the crystalline c -axis ($\vec{E} \parallel c$).

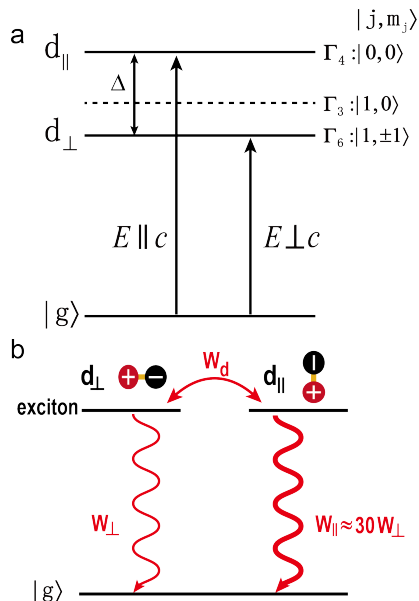

FIG. 2. (a) Schematic exciton levels in ϵ -GaSe at the Γ point and the representations to which the states at the Γ -point belong when including spin-orbit interaction. The energy splitting Δ between the Γ_4 (d_{\parallel}) and Γ_6 (d_{\perp}) exciton states is approximately 2 meV^{11,12}. (b) Schematic of the rate equation model.

To understand the unique polarization of the REL, we need to consider the selection rules and anisotropic optical constants in GaSe. We first examine the optical selection rules in GaSe and illustrate the spin-flip-induced conversion between the in-plane and out-of-plane dipoles (Fig. 2). The Se $4p_z$ states lie 1.2 and 1.6 eV above the Se $4p_{x,y}$ states as a result of the crystal field and spin-orbit interaction. Near the Γ point, direct optical transitions between the p_z -like uppermost valence band and s -like lowermost conduction band are dipole-allowed for light with the electric field parallel to the c -axis ($\vec{E} \parallel c$). For light with $\vec{E} \perp c$, the transitions become weakly allowed due to spin-orbit interaction⁷. The spin-dependent optical selection rules can be best understood in the two-particle (exciton) representation (Fig. 2a)^{11,12}. Optical excitation with $\vec{E} \perp c$ creates excitons with Γ_6 symmetry (d_{\perp} dipoles), which is analogous to a triplet state ($\uparrow\uparrow$ and $\downarrow\downarrow$). On the other hand, optical excitation with $\vec{E} \parallel c$ results in excitons with Γ_4 symmetry (d_{\parallel} dipoles), which is analogous to a singlet state ($\uparrow\downarrow - \downarrow\uparrow$). Therefore, a spin flip of either electron or hole of the exciton (e - h pair) results in the conversion between d_{\perp} and d_{\parallel} (Fig. 2b).

Experimentally, the absorption coefficient near the band edge for $\vec{E} \perp c$ is about $3 \times 10^{-3} \text{ cm}^{-1}$, which is a factor of 1/30 of that for light with $\vec{E} \parallel c$. Assuming that the spontaneous radiative recombination rate

is proportional to the absorption coefficient, we approximate the relative radiative recombination rates of the in-plane and out-plane dipoles to be $W_{\parallel}^r/W_{\perp}^r \approx 30$. As a result, under ps pulse excitation, luminescence is dominated by the radiative recombination of d_{\parallel} when the conversion between d_{\perp} and d_{\parallel} is fast compared with the recombination rates. The linear polarization of the REL is approximately $(W_{\parallel}^r - W_{\perp}^r)/(W_{\parallel}^r + W_{\perp}^r) \approx 0.94$, which is consistent with the measured *DoLP*.

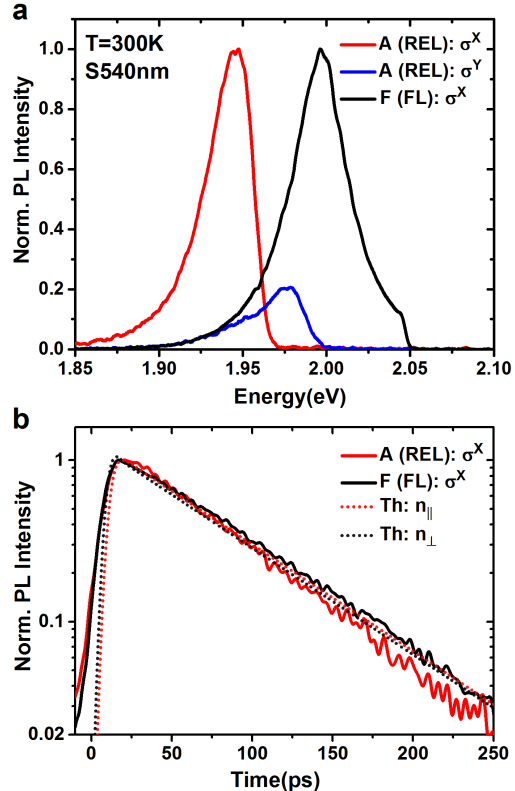

FIG. 3. (a) Polarized spectra of the FL (black curve) and the REL from location A (red and blue curves) in a 540 nm-thick GaSe slab at room temperature. The pump energy $E_p = 2.087$ eV and the pump flux $P = 1.0 P_0$. At room temperature, the FL is largely due to free excitons, and the backscattered REL intensity is considerably weaker than the FL (about a factor of four here). The *DoLP* is above 0.93 for $E < 1.95$ eV, where the anisotropic reabsorption for σ^X (TM mode) and σ^Y (TE mode) is negligible. (b) Time-dependent FL and REL. The FL (solid black curve) and the REL (solid red curve) show similar rise and decay times. The dotted black (red) curve is the calculated n_{\perp} (n_{\parallel}), which corresponds to the time-dependent luminescence from d_{\perp} (d_{\parallel}) dipoles. The theoretical curves are calculated with a rate equation model and convolved with an 8 ps (FWHM) instrument response. The fitting parameters are as follows: $W_{\perp}^r = 1/1000$, $W_{\parallel}^r = 30 W_{\perp}^r$, $W_d = 1/3$ [ps⁻¹].

In Fig. 3, we study the spectral and dynamic characteristics of the REL at room temperature. The REL remains highly linearly polarized, with a polarization orientation pointing to the photoexcited spot. The FL and REL are

nearly synchronized temporally without an identifiable time delay in the REL. Therefore, the REL cannot originate from carriers that are photoexcited at the focal spot and transported to the cleaved edges. We attribute the REL to the back scattered light from an index-guided optical TM mode with $\vec{E} \parallel c$. The d_{\parallel} converted from the photoexcited d_{\perp} radiate into this TM mode, which propagates in-plane from the photoexcited spot to the cleaved edges at the speed of light in the GaSe slab. The sub-10-ps rise time of the REL in Fig. 3 indicates that energy relaxation and conversion of photoexcited d_{\perp} and d_{\parallel} are less than 10 ps at room temperature^{11–13}.

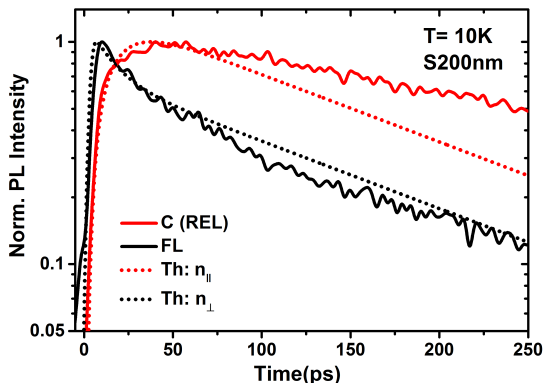

FIG. 4. Time-dependent FL (solid black line) and REL (solid red line) in a 200 nm-thick sample (S200nm). The REL is measured at location C, as indicated in Fig. 1h. The dotted black (red) line is the calculated time-dependent n_{\perp} (n_{\parallel}) convolved with a 4 ps (FWHM) instrument response function. The fitting parameters are as follows: $W_{\perp}^r = 1/2000$, $W_{\parallel}^r = 30 W_{\perp}^r$, $W_d = 1/30$ [ps^{-1}]. The slower decay of the REL relative to the FL is likely due to reabsorption, which results in the dominance of the REL by the low energy portion of the exciton luminescence.

The spin-flip-induced conversion between the in-plane and out-of-plane dipoles is evident in the time-dependent PL measurements at cryogenic temperature ($T = 10$ K), where the spin-flip rate is significantly reduced (Fig. 4). The FL arises within 10 ps after the pulse excitation, whereas the REL reaches its maximum about 50 ps afterward. The nearly instantaneous rise of the FL is the result of a sub-5-ps energy/momentum relaxation of photoexcited carriers, whereas the considerable delay of ~ 30 –50 ps rise time in the REL is due to the ~ 30 ps spin-flip time constant at $T = 10$ K.

The polarized time-dependent luminescence is reproduced by a rate equation model. Considering a spin-flip process and anisotropic radiative recombination rates for the in-plane and out-of-plane dipoles, we describe the time-dependent FL and REL with the following set of coupled differential equations:

$$\begin{aligned} \dot{n}_{\perp}(t) &= -W_{\perp}^r n_{\perp}(t) - W_d [n_{\perp}(t) - n_{\parallel}(t)] + G(t)P, \\ \dot{n}_{\parallel}(t) &= -W_{\parallel}^r n_{\parallel}(t) + W_d [n_{\perp}(t) - n_{\parallel}(t)]. \end{aligned}$$

The optical generation rate is approximated by a 2 ps Gaussian pulse $G(t)P$, where P is the pump flux. n_{\perp} and n_{\parallel} are the populations of the in-plane (d_{\perp}) and out-of-plane (d_{\parallel}) dipoles, whereas W_{\perp}^r and W_{\parallel}^r are the corresponding radiative recombination rates. W_d is the spin-flip rate that leads to the conversion between d_{\perp} and d_{\parallel} . In this simple model, we neglect the energy relaxation of nonresonantly excited carriers and non-radiative recombination loss. The time-dependent REL agrees with the calculated temporal evolution of n_{\parallel} , and indicates a rise time of ~ 30 ps that is consistent with the previously measured spin-flip time constant $\tau_s \approx 1/W_d$ ¹³. Similarly, the time-dependent FL is associated with the temporal evolution of n_{\perp} .

In summary, we have observed highly linearly polarized remote-edge luminescence in GaSe platelets with a thickness of 160 nm or more. The REL is due to the guided TM mode of luminescence from the out-of-plane dipoles that are converted from the in-plane dipoles photoexcited by normally incident ps pulses at a remote spot. One can anticipate linearly polarized stimulated emission or lasing in a GaSe platelets with a thickness of ~ 200 –300 nm and a lateral size of several micrometers when optical cavity effects are enhanced.

Materials and Methods. Sample preparation. GaSe nanoslabs are mechanically exfoliated from a Bridgman grown GaSe crystal³⁷ and deposited onto a 90-nm SiO_2/Si substrate. The samples studied in this study are mainly the ϵ modifications. A ϵ -GaSe crystal has ABA stacking of the individual layers and belongs to space group $D_{3h}^1/P\bar{6}m2$ (#187) and point group D_{3h} . An individual layer consists of four planes of Se-Ga-Ga-Se, with the Ga-Ga bond normal to the layer plane arranged on a hexagonal lattice and the Se anions located in the eclipsed conformation when viewed along the c -axis. The band-edge luminescence and absorption in ϵ -GaSe are around 630 nm (2.0 eV) and 595 nm (2.1 eV) at room temperature and $T = 10$ K, respectively. Samples are attached to a copper cold finger in an optical liquid-helium-flow cryostat and kept in a vacuum for all optical measurements.

Optical set-ups. A 2 ps pulse laser beam is focused through an objective (N.A. = 0.28) to an area of about $80 \mu\text{m}^2$. As a result, the electric field vector of the pump laser is orthogonal to the crystalline c -axis ($\vec{E} \perp c$). The photoexcitation density is from $\approx 2 \times 10^{16} \text{ cm}^{-3}$ to $3.4 \times 10^{17} \text{ cm}^{-3}$ ($2.7 \times 10^{-10} \text{ cm}^{-2}$ per layer) considering the absorption coefficient at 2.1 eV ($\approx 10^3 \text{ cm}^{-1}$ for $\vec{E} \perp c$) and Fresnel loss from reflection. The photoexcited density is below the Mott transition density in GaSe^{35,36}, which is about $4 \times 10^{17} \text{ cm}^{-3}$. The PL is collected through the same objective in the reflection geometry. The time-integrated PL spectra are measured with an imaging spectrometer (focal length: 750 mm; grating: 300 grooves/mm) equipped with a liquid-nitrogen cooled CCD camera. The time-resolved PL measurements are obtained with a streak camera system with a ~ 4 –10 ps (FWHM) temporal resolution depending on the exposure

time. The polarization properties of the pump laser and PL are controlled/analyzed by a combination of polarizers and liquid-crystal devices without mechanical moving parts.

Polarization. Linearly polarized light with horizontal (vertical) polarization is defined as σ^X (σ^Y). The circularly polarized pump or luminescence with angular momentum $+\hbar$ ($-\hbar$) along the pump laser wavevector $\hat{k} \parallel \hat{z}$ is defined as σ^+ (σ^-). The polarization state is characterized by the Stokes vector $\{S_0, S_1, S_2, S_3\}$. S_0 is the flux and is determined as $S_0 = I^X + I^Y$. The Stokes vector can be normalized by its flux S_0 to the Stokes three-vector $s = \{s_1, s_2, s_3\}$. $s_1 = (I^X - I^Y)/S_0$, $s_2 = (I^{45^\circ} - I^{135^\circ})/S_0$, and $s_3 = (I^+ - I^-)/S_0$. I^+ , I^- , I^X , I^Y , I^{45° , and I^{135° are measured intensities of the circularly or linearly polarized components. The degree of linear polarization is represented by $DoLP \equiv \sqrt{s_1^2 + s_2^2}$, and the polarization orientation angle is determined by $\tan^{-1}(s_2/s_1)$. The accuracy of the measurements of the $DoLP$ are within 1-2%.

*Guided TE and TM modes*³⁸. We define a parameter $V = (n_1^2 - n_2^2)^{1/2} k d_L$, which includes the difference in the squares of the refractive indices of the core (i.e., n_1 of the GaSe slab) and the substrate (i.e., n_2 of the SiO₂ layer), the vacuum wavelength (λ_0) and wavenumber ($2\pi/\lambda_0$), and the thickness of the core slab (d_L). The total number of TE or TM modes is then determined by the following equation:

$$N = \frac{1}{\pi} \left[V - \arctan \left(\eta \sqrt{\frac{n_2^2 - n_3^2}{n_1^2 - n_2^2}} \right) \right]_{int}$$

where n_3 is the refractive index of the capping layer (here vacuum), and the symbol $[\]_{int}$ indicates that N is the integer part of the number in brackets. The parameter η is defined as

$$\eta = \begin{cases} 1, & \text{for TE modes.} \\ n_1^2/n_3^2, & \text{for TM modes.} \end{cases}$$

The number of TE and TM modes is usually the same for most d_L . However, the number of TE modes can exceed that of the number of TM modes by one for specific ranges of d_L because $n_1/n_3 > 1$. For example, two TE modes and one TM modes exist for $243 \text{ nm} \lesssim d_L \lesssim 276 \text{ nm}$. Using $n_1 = 3.00$ (GaSe), $n_2 = 1.46$ (SiO₂), $n_3 = 1.00$ (vacuum), and $\lambda_0 = 600 \text{ nm}$ (band-edge exciton luminescence at T \sim 10 K), we determine the thickness required to sustain only one guided TM mode and one TE mode to be about 162 to 242 nm.

ACKNOWLEDGMENTS

This work was supported by NSF grant DMR-09055944 as well as a start-up funding and the Cowen endowment at Michigan State University. This research has used the W. M. Keck Microfabrication Facility. We thank Norman Birge, Brage Golding, and Bhanu Mahanti for the discussions.

* cwlai@msu.edu

- ¹ A. K. Geim and I. V. Grigorieva, "Van der Waals heterostructures," *Nature* **499**, 419–425 (2013).
- ² G. Eda and S. A. Maier, "Two-dimensional crystals: Managing light for optoelectronics." *ACS Nano* **7**, 5660–5665 (2013).
- ³ P. Miró, M. Audiffred, and T. Heine, "An atlas of two-dimensional materials," *Chem. Soc. Rev.* **43**, 6537–6554 (2014).
- ⁴ G. Fiori, F. Bonaccorso, G. Iannaccone, T. Palacios, D. Neumaier, A. Seabaugh, S. K. Banerjee, and L. Colombo, "Electronics based on two-dimensional materials," *Nature Nanotechnol.* **9**, 768 (2014).
- ⁵ M. Schlüter, "The electronic structure of GaSe," *Nuovo Cimento B* **13**, 313–360 (1973).
- ⁶ A. Bourdon and F. Khelladi, "Selection rule in the fundamental direct absorption of GaSe," *Solid State Commun.* **9**, 1715 – 1717 (1971).
- ⁷ A. Mercier, E. Mooser, and J. P. Voitchovsky, "Near edge optical absorption and luminescence of GaSe, GaS and of mixed crystals," *J. Lumin.* **7**, 241 – 266 (1973).
- ⁸ R. Le Toullec, N. Piccioli, M. Mejatty, and M. Balkanski, "Optical constants of ϵ -GaSe," *Nuovo Cimento B* **38**, 159–167 (1977).
- ⁹ N. Piccioli, R. Le Toullec, M. Mejatty, and M. Balkanski,

"Refractive index of GaSe between 0.45 μm and 330 μm ," *Appl. Opt.* **16**, 1236–1238 (1977).

- ¹⁰ R. Le Toullec, N. Piccioli, and J. C. Chervin, "Optical properties of the band-edge exciton in GaSe crystals at 10 K," *Phys. Rev. B* **22**, 6162 (1980).
- ¹¹ E. M. Gamarts, E. L. Ivchenko, M. I. Karaman, V. P. Mushinskii, G. E. Pikus, B. S. Razbirin, and A. N. Starukhin, "Optical orientation and alignment of free excitons in GaSe during resonance excitation. experiment," *Sov. Phys. JETP* **46**, 590 (1977).
- ¹² E. L. Ivchenko, G. E. Pikus, B. S. Razbirin, and A. I. Starukhin, "Optical orientation and alignment of free excitons in GaSe under resonant excitation. theory." *Sov. Phys. JETP* **45**, 1172–1180 (1977).
- ¹³ Y. Tang, W. Xie, K. C. Mandal, J. A. McGuire, and C. W. Lai, "Near unity optical spin polarization in GaSe nanoslabs," [arXiv:1410.5523](https://arxiv.org/abs/1410.5523) (2014).
- ¹⁴ F. Meier and B. P. Zakharchenya, "Optical orientation," (Elsevier, 1984).
- ¹⁵ J. Hu, L.-S. Li, W. Yang, L. Manna, L.-W. Wang, and A. P. Alivisatos, "Linearly polarized emission from colloidal semiconductor quantum rods," *Science* **292**, 2060–2063 (2001).
- ¹⁶ J. Wang, M. S. Gudixsen, X. Duan, Y. Cui, and C. M. Lieber, "Highly polarized photoluminescence and photode-

- tection from single indium phosphide nanowires,” *Science* **293**, 1455–1457 (2001).
- 17 J. C. Johnson, H. Yan, P. Yang, and R. J. Saykally, “Optical cavity effects in ZnO nanowire lasers and waveguides,” *J. Phys. Chem. B* **107**, 8816–8828 (2003).
 - 18 T. Takagahara, “Effects of dielectric confinement and electron-hole exchange interaction on excitonic states in semiconductor quantum dots,” *Phys. Rev. B* **47**, 4569–4585 (1993).
 - 19 D. Gammon, E. S. Snow, B. V. Shanabrook, D. S. Katzer, and D. Park, “Homogeneous linewidths in the optical spectrum of a single gallium arsenide quantum dot,” *Science* **273**, 87–90 (1996).
 - 20 R. I. Dzhiyev, B. P. Zakharchenya, E. L. Ivchenko, V. L. Korenev, Y. G. Kusraev, N. N. Ledentsov, V. M. Ustinov, A. E. Zhukov, and A. F. Tsatsul’nikov, “Optical orientation and alignment of excitons in quantum dots,” *Phys. Solid State* **40**, 790–793 (1998).
 - 21 M. Paillard, X. Marie, P. Renucci, T. Amand, A. Jbeli, and J. M. Gerard, “Spin relaxation quenching in semiconductor quantum dots,” *Phys. Rev. Lett.* **86**, 1634–1637 (2001).
 - 22 J. A. Schuller, S. Karaveli, T. Schiros, K. He, S. Yang, I. Kymissis, J. Shan, and R. Zia, “Orientation of luminescent excitons in layered nanomaterials,” *Nature Nanotechnol.* **8**, 271–276 (2013).
 - 23 A. M. Jones, H. Yu, N. J. Ghimire, S. Wu, G. Aivazian, J. S. Ross, B. Zhao, J. Yan, D. G. Mandrus, D. Xiao, W. Yao, and X. Xu, “Optical generation of excitonic valley coherence in monolayer WSe₂,” *Nature Nanotechnol.* **8**, 634 (2013).
 - 24 A. M. Jones, H. Yu, J. S. Ross, P. Klement, N. J. Ghimire, J. Yan, D. G. Mandrus, W. Yao, and X. Xu, “Spin-layer locking effects in optical orientation of exciton spin in bilayer WSe₂,” *Nature Phys.* **10**, 130–134 (2014).
 - 25 N. C. Ferneliuss, “Properties of gallium selenide single crystal,” *Prog. Crystal Growth and Charact. Mater.* **28**, 275–353 (1994).
 - 26 G. B. Abdullaev, L. A. Kulevskii, A. M. Prokhorov, A. D. Savel’Ev, E. Y. Salaev, and V. V. Smirnov, “GaSe, a new effective material for nonlinear optics,” *JETP Lett.* **16**, 90–95 (1972).
 - 27 K. R. Allakhverdiev, M. O. Yetis, S. Ozbek, T. K. Baykara, and E. Y. Salaev, “Effective nonlinear GaSe crystal. optical properties and applications,” *Laser Phys.* **19**, 1092–1104 (2009).
 - 28 R. E. Nahory, K. L. Shaklee, R. F. Leheny, and J. C. DeWinter, “Stimulated emission and the type of bandgap in GaSe,” *Solid State Commun.* **9**, 1107–1111 (1971).
 - 29 T. Ugmori, K. Masuda, and S. Namba, “Spontaneous and stimulated emission in GaSe under intense excitation,” *Solid State Commun.* **12**, 389–391 (1973).
 - 30 J. P. Voitchovsky and A. Mercier, “Photoluminescence of GaSe,” *Nuovo Cimento B* **22**, 273–292 (1974).
 - 31 A. Mercier and J. P. Voitchovsky, “Exciton-exciton and exciton-carrier scattering in GaSe,” *Phys. Rev. B* **11**, 2243–2250 (1975).
 - 32 T. Moriya and T. Kushida, “Luminescence spectra due to exciton-exciton collisions in semiconductors.: I. spontaneous emission spectra,” *J. Phys. Soc. Jpn.* **40**, 1668–1675 (1976).
 - 33 T. Moriya and T. Kushida, “Luminescence spectra due to exciton-exciton collisions in semiconductors. ii. stimulated emission spectra,” *J. Phys. Soc. Jpn.* **40**, 1676–1683 (1976).
 - 34 G. Bernier, S. Jandl, and R. Provencher, “Spontaneous and stimulated photoluminescence of GaSe in the energy range 2.075–2.125 eV,” *J. Lumin.* **35**, 289–300 (1986).
 - 35 L. Pavesi, J. L. Staehli, and V. Capozzi, “Mott transition of the excitons in GaSe,” *Phys. Rev. B* **39**, 10982–10994 (1989).
 - 36 V. Capozzi, L. Pavesi, and J. L. Staehli, “Exciton-carrier scattering in gallium selenide,” *Phys. Rev. B.* **47**, 6340–6349 (1993).
 - 37 K. C. Mandal, A. Mertiri, G. W. Pabst, R. G. Roy, Y. Cui, P. Battacharya, M. Groza, A. Burger, A. M. Conway, and R. J. Nikolic, “Layered III-VI chalcogenide semiconductor crystals for radiation detectors,” in *Proc. SPIE*, Vol. 7079 (2008) p. 707900.
 - 38 D. Marcuse, “The asymmetric slab waveguide,” in *Quantum electronics – Principles and applications* (1991) pp. 1–59.
 - 39 H. R. Gutiérrez, N. Perea-López, A. L. Elías, A. Berkdemir, B. Wang, Lv. Ruitao, F. López-Urías, V. H. Crespi, H. Terrones, and M. Terrones, “Extraordinary room-temperature photoluminescence in triangular WS₂ monolayers,” *Nano Lett.* **13**, 3447–3454 (2012).