

Design of Optimal Sparse Interconnection Graphs for Synchronization of Oscillator Networks

Makan Fardad, Fu Lin, and Mihailo R. Jovanović

Abstract

We study the optimal design of a conductance network as a means for synchronizing a given set of identical or nearly identical oscillators. Synchronization is said to be achieved when all oscillator voltages reach consensus. Synchronization performance is measured by the variance of the steady-state deviation from the consensus value of oscillator voltages, when all oscillators are subject to unit-variance noise excitations. We formulate optimization problems that address the trade-off between synchronization performance and the number and strength of oscillator couplings. We promote the sparsity of the coupling network by penalizing the number of interconnection links. For identical oscillators, we establish convexity of the optimization problem and demonstrate that the design problem can be formulated as a semidefinite program. For non-identical oscillators which can be considered as perturbations from a nominal oscillator, we show that it is meaningful to design an optimal conductance network by assuming that all oscillators are identical to the nominal oscillator. We justify this by demonstrating that the value of the optimal conductance matrix is insensitive (up to first order) to perturbations in the inductance values. Finally, for special classes of oscillator networks we derive explicit formulas for the optimal conductance values.

Index Terms

Consensus, convex relaxation, optimization, oscillator synchronization, reweighted ℓ_1 minimization, semidefinite programming, sparse graph.

Financial support from the National Science Foundation under awards CMMI-0927509 and CMMI-0927720 and under CAREER Award CMMI-0644793 is gratefully acknowledged.

M. Fardad is with the Department of Electrical Engineering and Computer Science, Syracuse University, NY 13244. F. Lin and M. R. Jovanović are with the Department of Electrical and Computer Engineering, University of Minnesota, Minneapolis, MN 55455. E-mails: makan@syr.edu, fu@umn.edu, mihailo@umn.edu.

I. INTRODUCTION AND MOTIVATION

Problems of synchronization are of interest in a variety of disciplines. In biology, examples include the synchronization of circadian pacemaker cells in the brain, pacemaker cells in the heart, and flashing fireflies and chirping crickets; we refer to [1] and references therein. In engineering and applied mathematics, extensive research has been devoted to the synchronization of networks of Kuramoto oscillators and networks of power generators [2]–[9]. Synchronization phenomena capture the attention of people with diverse backgrounds, as illustrated through the synchronization of mechanically coupled metronomes in the widely popular talk by Strogatz [10].

The literature on the synchronization of oscillator networks almost exclusively deals with finding conditions on oscillator couplings that guarantee their synchrony. These conditions are generally found for an *a priori* determined interconnection topology of the oscillators, and are often conservative. In the case of Kuramoto oscillators, a problem of particular interest is to characterize the onset of synchronization as a function of the coupling amplitude for a network of oscillators which are all coupled through *identical links*. Two aspects of the synchronization problem which seem to have not been adequately addressed in the literature are the issues of interconnection topology design, and, the optimality of the coupling coefficients. Indeed, a framework in which such problems can be formulated and solved seems to be lacking. This paper attempts to take a step in this direction by combining tools from optimal control theory and convex optimization.

We motivate the problem addressed in this paper, and discuss its relation to the existing literature on controller and network design, with the help of a simple example. Let two LC-oscillator circuits be connected by conductance $1/R$, as in Fig. 1a. Consider two extreme scenarios:

- $1/R = 0$: In this case the two oscillators are completely decoupled from each other, and each oscillates at its own resonance frequency $\omega_i = (L_i C_i)^{-1/2}$.
- $1/R = \infty$: In this case the two oscillators are fully coupled. The circuits can be parallel-combined into one oscillator, which oscillates at resonance frequency $\omega_0 \in [\omega_{\min}, \omega_{\max}]$ with $\omega_{\min} = \min\{\omega_1, \omega_2\}$ and $\omega_{\max} = \max\{\omega_1, \omega_2\}$. Thus the network achieves complete synchronization.

Clearly, in the first scenario we minimize coupling at the cost of not achieving any level of synchronization, and in the second scenario we achieve perfect synchronization at the cost of

maximal coupling. As opposed to these extreme cases, in this work we try to find a middle ground that strikes a balance between the amplitude of the coupling and the level of synchronization. We also point out that it is not necessary that the oscillators be different in order for the synchronization problem to be meaningful. Indeed even in the case of identical oscillators, problems of phase and amplitude synchronization require coupling between the network nodes.

We consider the synchronization problem for a network of n oscillators, and use the size of the conductance between any two nodes as a mathematical model for the amount of coupling between the corresponding oscillators. Our aim is to synchronize the network in a cost-effective way as far as the overall use of conductance is concerned. Synchronization performance is measured by the variance of the steady-state deviation from the consensus value of oscillator voltages, when all oscillators are subject to noise excitations. We employ an \mathcal{H}_2 optimal control framework to measure the amount of synchronization and also to penalize the amount of conductance used. Additionally, a weighted ℓ_1 norm of the conductance matrix is incorporated into the objective, to penalize *the number of* interconnection links and thus promote a sparse coupling network.

Our main contributions in this work can be summarized as follows. We employ tools from optimal control, compressive sensing, and convex optimization to formulate the synchronization problem and design optimal sparse interconnection graphs. We develop a procedure for eliminating unstable modes that are also unobservable, which in the case of the synchronization problem corresponds to the consensus mode. We identify a class of problems for which the design problem is convex, and provide a semidefinite programming formulation. Furthermore, we use perturbation analysis to demonstrate that the solution of the semidefinite program can be used as a design platform for more general nonconvex scenarios.

The problem of optimal controller design for large-scale and distributed systems has been considered in [11]–[25]. Particular attention is paid to the problem of optimal structured control in [26]–[28], where the \mathcal{H}_2 norm of the closed-loop system is minimized among all controllers that respect a predetermined communication structure. The problem of optimal sparse control is considered in [29]–[31], where a combination of \mathcal{H}_2 norm and sparsity-promoting penalty terms are minimized with the purpose of identifying controllers with minimal internodal communication links. The synchronization of coupled second-order linear harmonic oscillators with local interaction is considered in [9]. In this paper we adopt a framework which combines the optimization formulation of [29], [31] with the oscillator network model of [9].

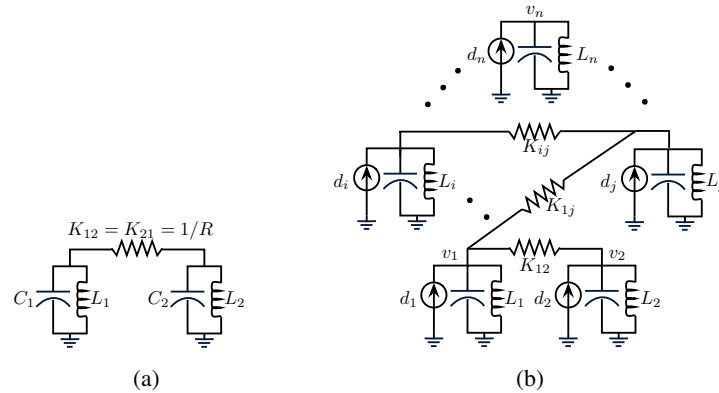

Fig. 1: Oscillator networks. (a) 2 oscillators coupled with conductance $1/R$. (b) n oscillators coupled with conductances described by matrix K .

The rest of the paper is organized as follows. In Section II we describe the state-space model and the optimization framework in which the optimal sparse conductance matrix is sought. In Section III-A we demonstrate that for identical oscillators, the problem of finding the optimal sparse conductance matrix is convex and can be formulated as a semidefinite program. In Section IV we consider nonidentical oscillators that are small deviations from a nominal oscillator, and show that an optimal conductance matrix found assuming that all oscillators are equal to the central oscillator yields a good starting point for a more accurate design. In Section V we present an illustrative example, and in Section VI we conclude with a summary of results and directions for future work. To improve readability we relegate all proofs to the Appendices.

II. PROBLEM FORMULATION

Consider a network of n LC-oscillators, interconnected by a set of conductances and subject to random current excitations. The conductances that connect different oscillators form the edges of an undirected (weighted) graph, with each oscillator connecting a node of the graph to the ground, as illustrated in Fig. 1b. For simplicity, we assume that

$$C_i = 1 \quad i = 1, \dots, n,$$

implying that, when considered in isolation, each oscillator resonates at frequency $\omega_i = L_i^{-1/2}$.

Let v denote the column vector of node voltages. Then, taking the integral of node voltages $\int_0^t v$ and the node voltages v as state variables, it is not difficult to show that the dynamics of

the entire network can be described by

$$\dot{\psi} = \begin{bmatrix} 0 & I \\ -H & -K \end{bmatrix} \psi + \begin{bmatrix} 0 \\ d \end{bmatrix}, \quad (1)$$

where $\psi = [\int_0^t v^T \quad v^T]^T$ is the state vector, d is the vector of disturbance currents injected into the nodes, and

$$H = \text{diag}\{1/L_i\}, \quad K : \text{conductance matrix of node interconnections.}$$

The conductance matrix K [32] can be thought of as a weighted Laplacian [32], [33], which by default satisfies $K \succeq 0$ and $K\mathbb{1} = 0$, with \succeq denoting inequality in the matrix semidefinite sense and $\mathbb{1}$ denoting the column vector of all ones. We assume that the system's graph is connected, which implies the positive definiteness of the matrix K when it is restricted to the subspace $\mathbb{1}^\perp$. Concisely, we write $K \in \mathcal{L}$ with

$$\mathcal{L} := \{K \mid K = K^T, K\mathbb{1} = 0, K + \mathbb{1}\mathbb{1}^T/n \succ 0, K_{ij} \leq 0 \text{ for } i \neq j\}. \quad (2)$$

The state-space description (1) resembles that in [9], where a spectral analysis of the A -matrix was performed to analyze the system's convergence properties.

It is desired to find an 'optimal' (in a sense to be made precise in what follows) matrix K such that

- (i) the difference in node voltages $|v_i - v_j|$ is kept small for every i and j ;
- (ii) the total amount of conductance used to connect nodes is kept small;
- (iii) the number of links between nodes is kept small.

Objective (i) attempts to synchronize the oscillators by keeping the node voltages close to each other. Objective (ii) tries to maintain a small level of coupling between the nodes. Objective (iii) aims to obtain a sparse interconnection topology. We note that objective (iii) is sometimes relaxed in this paper, for example, when a particular interconnection topology is determined *a priori* and optimal values of conductances are sought within that topology.

In order to place the problem of designing K in the framework of optimal control theory, we

rewrite system (1) in state-space form [34] as

$$\begin{aligned}\dot{\psi} &= A\psi + B_1 d + B_2 u, \\ z &= C_1 \psi + D u, \\ y &= C_2 \psi,\end{aligned}$$

with

$$u = -K y, \quad K \in \mathcal{L},$$

and

$$\begin{aligned}A &= \begin{bmatrix} 0 & I \\ -H & 0 \end{bmatrix}, \quad B_1 = \begin{bmatrix} 0 \\ I \end{bmatrix}, \quad B_2 = \begin{bmatrix} 0 \\ I \end{bmatrix}, \\ C_1 &= \begin{bmatrix} Q^{1/2} \\ 0 \end{bmatrix}, \quad C_2 = [0 \quad I], \quad D = \begin{bmatrix} 0 \\ R^{1/2} \end{bmatrix}.\end{aligned}$$

The variables d and u respectively represent the exogenous and control inputs that enter the nodes as currents, and the variables z and y respectively represent the performance and measurement outputs. The positive semidefinite matrix Q and the positive definite matrix R respectively quantify state and control weights. In this control-theoretic framework the matrix K denotes the static feedback gain, which is subject to the structural constraint of being in the set \mathcal{L} . Upon closing the loop, the above problem can equivalently be written as

$$\begin{aligned}\dot{\psi} &= (A - B_2 K C_2) \psi + B_1 d, \\ z &= \begin{bmatrix} Q^{1/2} \\ -R^{1/2} K C_2 \end{bmatrix} \psi,\end{aligned} \tag{3}$$

where it is easy to see that the closed-loop A -matrix, $A_{cl} = A - B_2 K C_2$, is given by the A -matrix in (1).

We further assume that

$$Q = \begin{bmatrix} 0 & 0 \\ 0 & Q_2 \end{bmatrix}, \tag{4}$$

where Q_2 satisfies $Q_2 \mathbb{1} = 0$ and is a positive definite matrix when restricted to the subspace $\mathbb{1}^\perp$,

i.e.,

$$Q_2 \mathbf{1} = 0, \quad \zeta^T Q_2 \zeta > 0 \text{ for all } \zeta \neq 0 \text{ such that } \zeta^T \mathbf{1} = 0,$$

and

$$R = r I, \quad r > 0.$$

To justify the structural assumptions on Q , we note that in order to achieve synchronization we are interested in making weighted sums of terms of the form $(v_i - v_j)^2$ small. Owing to the choice of state variables $[\int v^T \quad v^T]^T$, such an objective corresponds to Q matrices with the zero structure displayed in (4) and Q_2 matrices that are positive semidefinite and satisfy $Q_2 \mathbf{1} = 0$. For example, in a system of two oscillators, if it is desired to make $(v_1 - v_2)^2$ small then Q has the structure shown in (4) with

$$Q_2 = \begin{bmatrix} 1 \\ -1 \end{bmatrix} \begin{bmatrix} 1 & -1 \end{bmatrix} = \begin{bmatrix} 1 & -1 \\ -1 & 1 \end{bmatrix}.$$

We now state the main optimization problem addressed in this paper, then elaborate on the details of its formulation in the next paragraph. Consider the problem

$$\begin{aligned} & \text{minimize} && J_\gamma := \text{trace}(PB_1B_1^T) + \gamma \|W \circ K\|_{\ell_1} \\ & \text{subject to} && (A - B_2KC_2)^T P + P(A - B_2KC_2) = -(Q + C_2^T K^T R K C_2) \quad (5) \\ & && K \in \mathcal{L}, \quad P \succeq 0, \end{aligned}$$

where K is the optimization variable, $\|K\|_{\ell_1} = \sum_{i,j} |k_{ij}|$ is the ℓ_1 -norm of K , W is a weighting matrix, \circ denotes elementwise matrix multiplication, and \mathcal{L} is the set of weighted Laplacian matrices corresponding to connected graphs as defined in (2).

We next elaborate on the formulation of the optimization problem (5). When $\gamma = 0$, the objective function

$$J := \text{trace}(PB_1B_1^T)$$

is equal to the \mathcal{H}_2 norm, from input d to output z , of the closed-loop system (3). This can be interpreted as the amount of steady-state variance amplification from d to z , when the input d is a stochastic disturbance. Solving (5) for $\gamma = 0$ is closely related to the design of structured feedback gains [26]. The condition $K \in \mathcal{L}$ ensures that K is a legitimate conductance matrix. It

is important to note that due to our particular choice of the performance output z , by minimizing J we are effectively achieving the first two of our optimal synchronization objectives outlined earlier. Furthermore, it has been demonstrated recently that ℓ_1 optimization can often be used as a relaxation for cardinality minimization [35], [36], where the cardinality $\text{card}(K)$ of a matrix K is defined as the number of its nonzero entries. Indeed, the term $\gamma \|W \circ K\|_{\ell_1}$ in the objective function of (5) attempts to approximate $\gamma \text{card}(K)$ in penalizing the number of nonzero elements of K , which in terms of the synchronization problem can be interpreted as penalizing the number of interconnection links. The weighting matrix W can be updated via an iterative algorithm in order to make the weighted ℓ_1 norm $\|W \circ K\|_{\ell_1}$ a better approximation of $\text{card}(K)$ [31], [36]. We next describe one such algorithm.

A. Sparsity–Promoting Reweighted ℓ_1 Algorithm

Reference [36] introduces the *reweighted ℓ_1 minimization* algorithm as a relaxation for cardinality minimization. This methodology was recently used in [31] to find sparse optimal controllers for a class of distributed systems. We now state the reweighted ℓ_1 algorithm for the sparse optimal synchronization problem.

Algorithm 1 Reweighted ℓ_1 algorithm

- 1: **given** $\delta > 0$ and $\epsilon > 0$.
- 2: **for** $\mu = 1, 2, \dots$ **do**
- 3: **If** $\mu = 1$, set $K^{\text{prev}} := 0$, set $W_{ij} := 1$, form W .
- 4: **If** $\mu > 1$, set K^{prev} equal to optimal K from previous step, set

$$W_{ij} := \frac{1}{|K_{ij}^{\text{prev}}| + \delta},$$

- 5: form W .
 - 6: Solve (5) to obtain K^* .
 - 7: **If** $\|K^* - K^{\text{prev}}\| < \epsilon$, **quit**.
 - 7: **end for**
-

Henceforth in this paper, unless stated otherwise, we will only address solving the optimization problem (5) for a given weighting matrix W , which corresponds to Step 2 of the above algorithm.

B. Simplification of Problem (5)

We begin by exploiting the structure of the Lyapunov equation that appears in the optimization problem (5),

$$(A - B_2KC_2)^T P + P(A - B_2KC_2) = -(Q + C_2^T K^T R K C_2).$$

Substituting the expressions for A , B_2 , C_2 , Q , and

$$P = \begin{bmatrix} P_1 & P_0 \\ P_0^T & P_2 \end{bmatrix} \succeq 0,$$

yields

$$\begin{bmatrix} 0 & I \\ -H & -K \end{bmatrix}^T \begin{bmatrix} P_1 & P_0 \\ P_0^T & P_2 \end{bmatrix} + \begin{bmatrix} P_1 & P_0 \\ P_0^T & P_2 \end{bmatrix} \begin{bmatrix} 0 & I \\ -H & -K \end{bmatrix} = - \begin{bmatrix} 0 & 0 \\ 0 & Q_2 + rK^2 \end{bmatrix}. \quad (6)$$

Rewriting this equation in terms of its components gives

$$\begin{aligned} HP_0^T + P_0H &= 0 \\ P_0K - P_1 + HP_2 &= 0 \\ KP_2 + P_2K - P_0 - P_0^T &= Q_2 + rK^2. \end{aligned} \quad (7)$$

The condition $P \succeq 0$ implies that $P_1 \succeq 0$ and $P_2 \succeq 0$. Finally, we use the block decomposition of P to simplify the objective function in (5),

$$\text{trace}(PB_1B_1^T) = \text{trace}(P_2). \quad (8)$$

III. CASE OF UNIFORM INDUCTANCES: A CONVEX PROBLEM

In this section we make the following simplifying assumption, which we refer to as ‘uniform inductance’.

Assumption 1: Let all inductors have the same value, i.e.,

$$L_i = L_0, \quad i = 1, \dots, n, \quad (9)$$

for some $L_0 > 0$. This implies

$$H = (1/L_0)I \succ 0.$$

Remark 1: This assumption is restrictive in that all oscillator circuits now have the same resonance frequency $\omega_0 = L_0^{-1/2}$ (recall that all capacitor values are equal to one). However, the synchronization problem is still meaningful, as it forces the oscillators to reach consensus on their amplitudes and phases and oscillate in unison. In Section IV we show that the uniform inductance scenario provides a valuable design platform for the more general case in which different inductor values constitute small deviations from the nominal value L_0 .

From the uniform inductance assumption (9) it follows that $H = (1/L_0)I$ commutes with any matrix and therefore the first equation in (7) becomes

$$P_0 + P_0^T = 0.$$

Hence the last equation in (7) simplifies to

$$KP_2 + P_2K = Q_2 + rK^2, \quad (10)$$

with $P_2 \succeq 0$. Furthermore, from (8) it follows that the objective in (5) is equal to $\text{trace}(P_2)$ and is independent of P_0 and P_1 . The optimization problem (5) can thus be rewritten as

$$\begin{aligned} & \text{minimize} && \text{trace}(P_2) + \gamma \|W \circ K\|_{\ell_1} \\ & \text{subject to} && KP_2 + P_2K = Q_2 + rK^2 \\ & && K \in \mathcal{L}, \quad P_2 \succeq 0. \end{aligned} \quad (11)$$

To simplify the optimization problem further, we state the following useful lemma.

Lemma 1: Let \mathcal{A} and \mathcal{Q} be given symmetric matrices that satisfy $\mathcal{A}\mathbf{1} = \mathcal{Q}\mathbf{1} = 0$, and suppose that \mathcal{A} is negative definite when restricted to the subspace $\mathbf{1}^\perp$. For the Lyapunov equation

$$\mathcal{A}^T \mathcal{P} + \mathcal{P} \mathcal{A} = -\mathcal{Q}, \quad (12)$$

the following statements hold.

- (i) If \mathcal{P} is a solution of the Lyapunov equation (12) then so is $\mathcal{P} + \alpha \mathbf{1}\mathbf{1}^T$ for any $\alpha \in \mathbb{R}$.
- (ii) If \mathcal{P} is a solution of the Lyapunov equation (12) and \mathcal{Q} is positive semidefinite on $\mathbf{1}^\perp$, then $\mathbf{1}$ is an eigenvector of \mathcal{P} and \mathcal{P} is positive semidefinite on $\mathbf{1}^\perp$. Furthermore, among

all $\mathcal{P} \succeq 0$ that satisfy (12) the one with the minimum trace satisfies $\mathcal{P}\mathbf{1} = 0$.

(iii) Any solution \mathcal{P} of the Lyapunov equation (12) satisfies

$$\begin{aligned}\text{trace}(\mathcal{P}) &= p - (1/2) \text{trace}(\mathcal{Q}\mathcal{A}^\dagger), \\ \mathcal{P} &= (p/n) \mathbf{1}\mathbf{1}^T + \mathcal{P}^\perp,\end{aligned}$$

for some $p \in \mathbb{R}$ and matrix \mathcal{P}^\perp , where p is independent of \mathcal{A} and \mathcal{Q} , $\mathcal{P}^\perp\mathbf{1} = 0$, and \mathcal{A}^\dagger denotes the Moore–Penrose pseudoinverse of \mathcal{A} . Additionally, if \mathcal{Q} is positive semidefinite on $\mathbf{1}^\perp$ then so is \mathcal{P}^\perp .

(iv) The identity $\text{trace}(\mathcal{Q}\mathcal{A}^\dagger) = \text{trace}(\mathcal{Q}(\mathcal{A} - \mathbf{1}\mathbf{1}^T/n)^{-1})$ holds and any solution \mathcal{P} of the Lyapunov equation (12) satisfies

$$\text{trace}(\mathcal{P}) = p - (1/2) \text{trace}(\mathcal{Q}(\mathcal{A} - \mathbf{1}\mathbf{1}^T/n)^{-1}),$$

where $p \in \mathbb{R}$ is independent of \mathcal{A} and \mathcal{Q} .

Proof: See Appendix. ■

Remark 2: An important consequence of Lemma 1 is that the new description of $\text{trace}(\mathcal{P})$,

$$\begin{aligned}\text{trace}(\mathcal{P}) &= p - (1/2) \text{trace}(\mathcal{Q}(\mathcal{A} - \mathbf{1}\mathbf{1}^T/n)^{-1}) \\ &= p - (1/2) \text{trace}(\mathcal{Q}^{1/2}(\mathcal{A} - \mathbf{1}\mathbf{1}^T/n)^{-1}\mathcal{Q}^{1/2}),\end{aligned}$$

lends itself to the application of semidefinite programming (SDP) methods, as we demonstrate below. This is reminiscent of the results in [32].

Remark 3: We will demonstrate that, in the case of uniform inductances, p is a free parameter whose value does not affect the optimal inductance matrix we seek. It turns out that when the uniform inductance assumption is removed then p takes on a determinate value. However, the optimization problem and the optimal inductance will continue to be independent of p , as we show in Section IV.

Applying Lemma 1 with $\mathcal{A} = -K$ and $\mathcal{Q} = Q_2 + rK^2$ to the Lyapunov equation (10) with

$P_2 \succeq 0$ gives

$$\begin{aligned}
\text{trace}(P_2) &= p + (1/2) \text{trace}((Q_2 + rK^2)K^\dagger) \\
&= p + (1/2) \text{trace}(Q_2(K + \mathbb{1}\mathbb{1}^T/n)^{-1} + rK(I - \mathbb{1}\mathbb{1}^T/n)) \\
&= p + (1/2) \text{trace}(Q_2^{1/2}(K + \mathbb{1}\mathbb{1}^T/n)^{-1}Q_2^{1/2} + rK), \tag{13}
\end{aligned}$$

where $p \in \mathbb{R}$ is independent of K and Q_2 . The details of the simplifications in (13) are as follows: Since K is the Laplacian of a connected graph then $K\mathbb{1} = 0$ and K is positive definite on $\mathbb{1}^\perp$. Also, by assumption $Q_2\mathbb{1} = 0$ and Q_2 is positive definite on $\mathbb{1}^\perp$. Thus $(Q_2 + rK^2)\mathbb{1} = 0$ and $Q_2 + rK^2$ is positive definite on $\mathbb{1}^\perp$. Therefore Lemma 1 applies and the first equation follows. In the second equation, $Q\mathbb{1} = 0$ and the identities $K^\dagger = (K + \mathbb{1}\mathbb{1}^T/n)^{-1} - \mathbb{1}\mathbb{1}^T/n$, $K^\dagger K = I - \mathbb{1}\mathbb{1}^T/n$ are invoked. Finally, the last equation follows from $K\mathbb{1} = 0$ and the trace identity $\text{trace}(M_1M_2) = \text{trace}(M_2M_1)$.

In summary, problem (5), which had been simplified to (11) using the uniform inductance assumption (9), is further simplified with the help of Lemma 1 and (13) to obtain the equivalent problem

$$\begin{aligned}
&\text{minimize} \quad (1/2) \text{trace}(Q_2^{1/2}(K + \mathbb{1}\mathbb{1}^T/n)^{-1}Q_2^{1/2} + rK) + \gamma \|W \circ K\|_{\ell_1} \\
&\text{subject to} \quad K \in \mathcal{L}, \tag{14}
\end{aligned}$$

where the parameter p has been dropped from the objective, as it has no effect on the solution of the optimization problem.

A. SDP Formulation

The following proposition provides an SDP formulation of (14).

Proposition 2: The optimization problem (5), under the uniform inductance assumption (9),

is equivalent to the semidefinite program

$$\begin{aligned}
& \text{minimize} && (1/2) \text{trace}(X + rK) + \gamma \text{trace}(\mathbb{1}\mathbb{1}^T Y) \\
& \text{subject to} && \begin{bmatrix} X & Q_2^{1/2} \\ Q_2^{1/2} & K + \mathbb{1}\mathbb{1}^T/n \end{bmatrix} \succeq 0 \\
& && M \circ K \leq 0, \quad K\mathbb{1} = 0 \\
& && -Y \leq W \circ K \leq Y,
\end{aligned} \tag{15}$$

where the optimization variables are the symmetric matrices K and X and the elementwise-nonnegative matrix Y , \leq denotes elementwise inequality of matrices, and

$$M := \mathbb{1}\mathbb{1}^T - I \sim \begin{bmatrix} 0 & 1 & 1 \\ 1 & 0 & 1 \\ 1 & 1 & 0 \end{bmatrix}.$$

Proof: See Appendix. ■

We note that the optimal conductance matrix is independent of the inductance matrix H when all inductances have the same value. In other words, the optimal K does not depend on the oscillator parameters when all oscillators are identical.

B. Special Case: Uniform All-To-All Coupling

A problem of particular interest in oscillator synchronization is that of uniform all-to-all coupling [1]. This scenario, although nonsparse, can be easily addressed using the framework developed in this paper. In this case every oscillator is connected to all other oscillators and all couplings have the same magnitude (i.e., all conductances have the same value). This implies a particular structure on K ,

$$K = k(I - \mathbb{1}\mathbb{1}^T/n),$$

where k is a positive scalar.

In the uniform all-to-all coupling problem the structure of K is already determined, thus the sparsity-promoting term $\gamma \|W \circ K\|_{\ell_1}$ can be removed from the objective of (14). Equivalently, we can consider (14) with $\gamma = 0$. Clearly, the reweighted ℓ_1 algorithm is unnecessary in this case (as W is not used and does not need to be updated), and the problem simplifies to finding

the value of k that minimizes $J = \text{trace}(P_2)$.

It is easy to show that

$$K^\dagger = (1/k) (I - \mathbf{1}\mathbf{1}^T/n).$$

Thus from (13) it follows that

$$\begin{aligned} 2J &= \text{trace}((Q_2 + rK^2)K^\dagger) \\ &= (1/k) \text{trace}(Q_2(I - \mathbf{1}\mathbf{1}^T/n)) + rk \text{trace}((I - \mathbf{1}\mathbf{1}^T/n)^3) \\ &= (1/k) \text{trace}(Q_2) + rk(n-1). \end{aligned}$$

Setting $\partial J/\partial k = 0$ we obtain

$$k = \left(\frac{\text{trace}(Q_2)}{(n-1)r} \right)^{1/2},$$

and therefore the optimal conductance matrix is given by

$$K = \left(\frac{\text{trace}(Q_2)}{(n-1)r} \right)^{1/2} (I - \mathbf{1}\mathbf{1}^T/n). \quad (16)$$

Notice that the optimal conductance matrix depends only on the trace of Q_2 and not on its exact structure or its individual entries.

IV. GRADIENT OF J AND CASE OF NONUNIFORM INDUCTANCES

In this section we consider the case of nonuniform inductances. We demonstrate that an optimal design performed for networks with uniform inductances serves as a good starting point for an optimal design for networks that do not satisfy this assumption, as long as the inductance values are close to each other.

Let inductor values L_i constitute small deviations from some nominal value L_0 ,

$$L_i = L_0 + \delta L_i, \quad i = 1, \dots, n, \quad (17)$$

with

$$|\delta L_i| \ll L_0,$$

In this case, once the interconnection topology and link weights have been determined by solving the optimization problem (5) under the assumption (9), a perturbation analysis can be employed

to update the conductance matrix to accommodate for the nonuniform inductance values in (17). We refer the reader to [27], [28] for additional information regarding use of perturbation methods in the design of optimal distributed controllers.

Proposition 3: Consider the problem of minimizing $J = \text{trace}(PB_1B_1^T)$ subject to the equations (7) and the constraints $K \in \mathcal{L}$, $P \succeq 0$. Small changes δH and δK in the inductance and conductance matrices, respectively, around the point $H = (1/L_0)I$ and K , result in small changes $\delta J = \text{trace}(\delta PB_1B_1^T)$ in the value of the objective function. Then

$$\delta J = \delta p + (1/2) \text{trace}((rI - K^\dagger Q_2 K^\dagger) \delta K),$$

where δp is a function of δH but is independent of δK . In particular,

$$\nabla_K J = (1/2) (rI - K^\dagger Q_2 K^\dagger),$$

where the gradient is evaluated at the point $((1/L_0)I, K)$.

Proof: See Appendix. ■

We point out that the conditions $P_2 \mathbf{1} = 0$ and $\delta P_2 \mathbf{1} = 0$ are used to remove the ambiguity from the Lyapunov equations that define P_2 and δP_2 , by invoking Lemma 1 to select a minimum-trace solution.

Remark 4: The utility of Proposition 3 can be explained as follows.

- If the inductances of different oscillators can be considered as small perturbations from some nominal value L_0 and thus

$$H(\varepsilon) = H^{(0)} + \varepsilon H^{(1)},$$

with

$$H^{(0)} = (1/L_0)I,$$

then the expression for δJ given in Proposition 3 implies that at least *up to first order in ε* , the value of the optimal K remains unaffected by variations $H^{(1)}$ in H . This shows a degree of *insensitivity* of the optimal K to the deviation of inductances from their nominal value L_0 . This effectively implies that an optimal design performed for the case of uniform inductances serves as a good estimate for the globally optimal solution in the case of

nonuniform inductances, if the inductances comprise perturbations from a nominal value.

- The gradient $\nabla_K J = (1/2)(rI - K^\dagger Q_2 K^\dagger)$ can be used to compute a descent direction in numerical optimization methods. Furthermore, setting $\nabla_K J = 0$ gives

$$K^\dagger Q_2 K^\dagger = rI$$

as a necessary condition for optimality. Multiplying both sides by K and using $KK^\dagger = K^\dagger K = I - \mathbf{1}\mathbf{1}^T/n$, $Q_2\mathbf{1} = 0$, results in $K^2 = Q_2/r$. Thus the optimal K is given by

$$K = Q_2^{1/2}/r^{1/2}. \quad (18)$$

V. ILLUSTRATIVE EXAMPLES

A. Example 1

In this section we consider $n = 7$ identical oscillators and design a sparse conductance matrix using the sparsity-promoting algorithm of Section II, with the optimization problem in Step 2 of the algorithm being (15).

Let $r = 1$ and

$$Q_2 = \begin{bmatrix} 1 & -1 & 0 & 0 & 0 & 0 & 0 \\ -1 & 2 & -1 & 0 & 0 & 0 & 0 \\ 0 & -1 & 2 & -1 & 0 & 0 & 0 \\ 0 & 0 & -1 & 2 & -1 & 0 & 0 \\ 0 & 0 & 0 & -1 & 2 & -1 & 0 \\ 0 & 0 & 0 & 0 & -1 & 2 & -1 \\ 0 & 0 & 0 & 0 & 0 & -1 & 1 \end{bmatrix}.$$

The optimal conductance matrices K_γ , for different values of γ , are given below. For all computations we used CVX, a package for specifying and solving convex programs [37], [38]. As expected, for $\gamma = 0$ we recover $K_0 = Q_2^{1/2}/r^{1/2}$.

$$K_0 = \begin{bmatrix} 0.84 & -0.52 & -0.13 & -0.07 & -0.05 & -0.04 & -0.03 \\ -0.52 & 1.23 & -0.46 & -0.11 & -0.06 & -0.04 & -0.04 \\ -0.13 & -0.46 & 1.25 & -0.45 & -0.11 & -0.06 & -0.05 \\ -0.07 & -0.11 & -0.45 & 1.25 & -0.45 & -0.11 & -0.07 \\ -0.05 & -0.06 & -0.11 & -0.45 & 1.25 & -0.46 & -0.13 \\ -0.04 & -0.04 & -0.06 & -0.11 & -0.46 & 1.23 & -0.52 \\ -0.03 & -0.04 & -0.05 & -0.07 & -0.13 & -0.52 & 0.84 \end{bmatrix}$$

$$\begin{aligned}
K_{0.01} &= \begin{bmatrix} 0.80 & -0.55 & -0.14 & 0 & 0 & 0 & -0.11 \\ -0.55 & 1.19 & -0.47 & -0.17 & 0 & 0 & 0 \\ -0.14 & -0.47 & 1.22 & -0.45 & -0.16 & 0 & 0 \\ 0 & -0.17 & -0.45 & 1.24 & -0.45 & -0.17 & 0 \\ 0 & 0 & -0.16 & -0.45 & 1.22 & -0.47 & -0.14 \\ 0 & 0 & 0 & -0.17 & -0.47 & 1.19 & -0.55 \\ -0.11 & 0 & 0 & 0 & -0.14 & -0.55 & 0.80 \end{bmatrix} \\
K_{0.1} &= \begin{bmatrix} 0.57 & -0.57 & 0 & 0 & 0 & 0 & 0 \\ -0.57 & 1.14 & -0.57 & 0 & 0 & 0 & 0 \\ 0 & -0.57 & 1.14 & -0.57 & 0 & 0 & 0 \\ 0 & 0 & -0.57 & 1.14 & -0.57 & 0 & 0 \\ 0 & 0 & 0 & -0.57 & 1.14 & -0.57 & 0 \\ 0 & 0 & 0 & 0 & -0.57 & 1.14 & -0.57 \\ 0 & 0 & 0 & 0 & 0 & -0.57 & 0.57 \end{bmatrix}
\end{aligned}$$

B. Example 2

We consider the all-to-all coupling example of Section III-B. We show the insensitivity of J to deviations of inductances from a uniform nominal value.

Let

$$Q_2 = q(I - \mathbf{1}\mathbf{1}^T/n), \quad K = k(I - \mathbf{1}\mathbf{1}^T/n),$$

where q and k are positive scalars. We demonstrate that

$$P_0 = 0, \quad P_1 = HP_2, \quad P_2 = \phi I + \alpha \mathbf{1}\mathbf{1}^T,$$

with appropriate values of $\phi, \alpha \in \mathbb{R}$, serves as the solution to the set of equations (7). Substitution into the last equation of (7) gives

$$2\phi k(I - \mathbf{1}\mathbf{1}^T/n) = (q + rk^2)(I - \mathbf{1}\mathbf{1}^T/n),$$

or

$$\phi = \frac{q + rk^2}{2k}.$$

Thus $P_2 = ((q + rk^2)/(2k))I + \alpha \mathbf{1}\mathbf{1}^T$ satisfies the last equation in (7) for any $\alpha \in \mathbb{R}$. In

the case of uniform inductors, when H is a multiple of the identity $H = (1/L_0)I$, the second equation in (7) renders $P_1 = ((q + rk^2)/(2L_0k))I + (\alpha/L_0)\mathbb{1}\mathbb{1}^T$. Thus the freedom in choosing α extends to the matrix P_1 . This is not surprising, since in the case of uniform inductors the closed-loop A -matrix in (1) has a pair of eigenvalues on the imaginary axis, which results in nonunique solutions to the Lyapunov equation (6). However, in the case of nonuniform inductors the equation $P_1 = HP_2$, together with the symmetry condition on P_1 , forces α to be zero. Hence

$$P_0 = 0, \quad P_1 = \frac{q + rk^2}{2k} H, \quad P_2 = \frac{q + rk^2}{2k} I,$$

is the solution of (7), and

$$J = \text{trace}(PB_1B_1^T) = \text{trace}(P_2) = \frac{q + rk^2}{2k} n.$$

Setting $\partial J/\partial k = 0$ we obtain

$$k = (q/r)^{1/2},$$

and therefore the optimal conductance matrix is given by

$$K = (q/r)^{1/2}(I - \mathbb{1}\mathbb{1}^T/n).$$

Indeed, the above expression for the optimal K is in complete agreement with those given in (16) and (18), since $\text{trace}(Q_2) = q \text{trace}(I - \mathbb{1}\mathbb{1}^T/n) = q(n - 1)$ and $Q_2^{1/2} = q^{1/2}(I - \mathbb{1}\mathbb{1}^T/n)$.

Clearly, for this simple example J is *independent* of H , and therefore so is the optimal K . In particular, the optimal K is insensitive to changes in the inductance values.

VI. CONCLUSIONS AND FUTURE WORK

We have proposed an optimization framework for the design of (sparse) interconnection graphs in LC-oscillator synchronization problems. We have identified scenarios under which the optimization problem is convex and can be solved efficiently.

Our ultimate goal is to establish a constructive framework for the synchronization of oscillator networks, in which not just the issue of synchronization but the broader questions of optimality and design of interconnection topology can be addressed. For example, it can be shown that a linearization around the consensus state of the nonlinear ‘swing equations,’ that arise in the description of power systems, can be placed in the design framework developed in this paper and

ultimately expressed as a semidefinite program. As another example, it can be shown that after applying a sequence of transformations to (3), the resulting equations closely resemble those of the Kuramoto oscillator. We aim to exploit these similarities for the purpose of optimal network design in our future work.

APPENDIX

Proof of Lemma 1

The proof is based on using a special similarity transformation to eliminate the common zero mode of \mathcal{A} and \mathcal{Q} from the Lyapunov equation $\mathcal{A}^T \mathcal{P} + \mathcal{P} \mathcal{A} = -\mathcal{Q}$.

To prove (i), let \mathcal{P} satisfy the Lyapunov equation in the statement of the lemma. Recalling that \mathcal{A} is symmetric and $\mathcal{A}\mathbf{1} = 0$, we have $\mathcal{A}^T(\mathcal{P} + \alpha \mathbf{1} \mathbf{1}^T) = \mathcal{A}^T \mathcal{P}$ and $(\mathcal{P} + \alpha \mathbf{1} \mathbf{1}^T) \mathcal{A} = \mathcal{P} \mathcal{A}$, where α is a free parameter. Thus

$$\mathcal{A}^T(\mathcal{P} + \alpha \mathbf{1} \mathbf{1}^T) + (\mathcal{P} + \alpha \mathbf{1} \mathbf{1}^T) \mathcal{A} = -\mathcal{Q},$$

and $\mathcal{P} + \alpha \mathbf{1} \mathbf{1}^T$ too satisfies the Lyapunov equation. This proves statement (i).

To prove (ii), note that since \mathcal{A} is symmetric it can be diagonalized using a unitary transformation \mathcal{V} ,

$$\mathcal{A} = \mathcal{V} \Lambda \mathcal{V}^T,$$

where v_i , $i = 1, \dots, n$ denote the orthonormal eigenvectors of \mathcal{A} and constitute the columns of \mathcal{V} ; λ_i , $i = 1, \dots, n$ denote the eigenvalues of \mathcal{A} and constitute the diagonal elements of Λ , $\Lambda = \text{diag}\{\lambda_i, i = 1, \dots, n\}$. Recalling that $\mathcal{A}\mathbf{1} = 0$, we assume without loss of generality that

$$\lambda_1 = 0, \quad v_1 = \mathbf{1}/\sqrt{n}.$$

Then $\mathcal{V} = \begin{bmatrix} \frac{1}{\sqrt{n}} \mathbf{1} & \tilde{\mathcal{V}} \end{bmatrix}$ with $\tilde{\mathcal{V}}^T \mathbf{1} = 0$, and

$$\mathcal{V}^T \mathcal{A} \mathcal{V} = \begin{bmatrix} \frac{1}{\sqrt{n}} \mathbf{1}^T \\ \tilde{\mathcal{V}}^T \end{bmatrix} \mathcal{A} \begin{bmatrix} \frac{1}{\sqrt{n}} \mathbf{1} & \tilde{\mathcal{V}} \end{bmatrix} = \begin{bmatrix} 0 & 0 \\ 0 & \tilde{\Lambda} \end{bmatrix},$$

where $\tilde{\Lambda} = \text{diag}\{\lambda_i, i = 2, \dots, n\}$. Since \mathcal{A} is negative definite on $\mathbb{1}^\perp$ then $\tilde{\Lambda} \prec 0$. Similarly

$$\mathcal{V}^T \mathcal{Q} \mathcal{V} = \begin{bmatrix} 0 & 0 \\ 0 & \tilde{\mathcal{Q}} \end{bmatrix},$$

which results from $\mathcal{Q}\mathbb{1} = 0$ and the symmetry of \mathcal{Q} . If we further assume that \mathcal{Q} is positive semidefinite on $\mathbb{1}^\perp$ then $\tilde{\mathcal{Q}} \succeq 0$.

Considering the Lyapunov equation $\mathcal{A}^T \mathcal{P} + \mathcal{P} \mathcal{A} = -\mathcal{Q}$ and multiplying both sides from the left by \mathcal{V}^T and from the right by \mathcal{V} , we obtain

$$\begin{aligned} \mathcal{V}^T \mathcal{A} \mathcal{P} \mathcal{V} + \mathcal{V}^T \mathcal{P} \mathcal{A} \mathcal{V} &= \mathcal{V}^T \mathcal{A} \mathcal{V} \mathcal{V}^T \mathcal{P} \mathcal{V} + \mathcal{V}^T \mathcal{P} \mathcal{V} \mathcal{V}^T \mathcal{A} \mathcal{V} \\ &= -\mathcal{V}^T \mathcal{Q} \mathcal{V}. \end{aligned}$$

Using

$$\mathcal{V}^T \mathcal{P} \mathcal{V} =: \begin{bmatrix} p_1 & p_0^T \\ p_0 & \tilde{\mathcal{P}} \end{bmatrix}$$

we arrive at

$$\begin{bmatrix} 0 & 0 \\ 0 & \tilde{\Lambda} \end{bmatrix} \begin{bmatrix} p_1 & p_0^T \\ p_0 & \tilde{\mathcal{P}} \end{bmatrix} + \begin{bmatrix} p_1 & p_0^T \\ p_0 & \tilde{\mathcal{P}} \end{bmatrix} \begin{bmatrix} 0 & 0 \\ 0 & \tilde{\Lambda} \end{bmatrix} = - \begin{bmatrix} 0 & 0 \\ 0 & \tilde{\mathcal{Q}} \end{bmatrix},$$

where p_1 is a scalar, p_0 is a column vector, and $\tilde{\mathcal{P}}$ is a matrix. Rewriting the above equation component-wise gives

$$\tilde{\Lambda} p_0 = 0, \quad \tilde{\Lambda} \tilde{\mathcal{P}} + \tilde{\mathcal{P}} \tilde{\Lambda} = -\tilde{\mathcal{Q}},$$

and p_1 is a (\mathcal{A} - and \mathcal{Q} -independent) free parameter. From $\tilde{\Lambda} \prec 0$ it follows that $p_0 = 0$, and therefore

$$\mathcal{P} \mathcal{V} = \mathcal{V} \begin{bmatrix} p_1 & 0 \\ 0 & \tilde{\mathcal{P}} \end{bmatrix}.$$

In particular, this implies $\mathcal{P}\mathbb{1} = p_1\mathbb{1}$ and thus $\mathbb{1}$ is an eigenvector of \mathcal{P} with p_1 as its corresponding eigenvalue. Furthermore, it is easy to show that $\tilde{\mathcal{P}} := \int_0^\infty e^{\tilde{\Lambda}t} \tilde{\mathcal{Q}} e^{\tilde{\Lambda}t} dt$ is the unique solution to the Lyapunov equation $\tilde{\Lambda} \tilde{\mathcal{P}} + \tilde{\mathcal{P}} \tilde{\Lambda} = -\tilde{\mathcal{Q}}$ when $\tilde{\Lambda} \prec 0$. If we assume that $\tilde{\mathcal{Q}} \succeq 0$ then $\tilde{\mathcal{P}} \succeq 0$, and \mathcal{P} is positive semidefinite when restricted to the subspace $\mathbb{1}^\perp$.

Finally, we have

$$\text{trace}(\mathcal{P}) = p_1 + \text{trace}(\tilde{\mathcal{P}}).$$

If $\mathcal{P} \succeq 0$ then $p_1 \geq 0$, in addition to $\tilde{\mathcal{P}} \succeq 0$. Hence the minimum trace of \mathcal{P} is achieved for $p_1 = 0$, which renders $\mathcal{P}\mathbf{1} = 0$. This proves statement (ii).

To prove (iii), we note that

$$\begin{aligned} \mathcal{P} &= \mathcal{V} \begin{bmatrix} p_1 & 0 \\ 0 & \tilde{\mathcal{P}} \end{bmatrix} \mathcal{V}^T \\ &= (p_1/n) \mathbf{1}\mathbf{1}^T + \tilde{\mathcal{V}}\tilde{\mathcal{P}}\tilde{\mathcal{V}}^T, \end{aligned}$$

with $\tilde{\mathcal{V}}\tilde{\mathcal{P}}\tilde{\mathcal{V}}^T\mathbf{1} = 0$. If we additionally assume that \mathcal{Q} is positive semidefinite on $\mathbf{1}^\perp$, then $\tilde{\mathcal{Q}} \succeq 0$, $\tilde{\mathcal{P}} \succeq 0$, and $\mathcal{P}^\perp := \tilde{\mathcal{V}}\tilde{\mathcal{P}}\tilde{\mathcal{V}}^T$ is positive semidefinite on $\mathbf{1}^\perp$.

Also, from $\tilde{\Lambda}\tilde{\mathcal{P}} + \tilde{\mathcal{P}}\tilde{\Lambda} = -\tilde{\mathcal{Q}}$ and [39, Lemma 1] we have $\text{trace}(\tilde{\mathcal{P}}) = -(1/2)\text{trace}(\tilde{\mathcal{Q}}\tilde{\Lambda}^{-1})$, which implies

$$\begin{aligned} \text{trace}(\mathcal{P}) &= p_1 + \text{trace}(\tilde{\mathcal{P}}) \\ &= p_1 - (1/2)\text{trace}(\tilde{\mathcal{Q}}\tilde{\Lambda}^{-1}). \end{aligned}$$

To further simplify the above expression and express $\text{trace}(\mathcal{P})$ in terms of the Moore–Penrose pseudoinverse \mathcal{A}^\dagger , note that from $\mathcal{A} = \mathcal{V}\Lambda\mathcal{V}^T$ and the SVD procedure for finding the pseudoinverse, we have

$$\mathcal{A}^\dagger = \mathcal{V}\Lambda^\dagger\mathcal{V}^T = \mathcal{V} \begin{bmatrix} 0 & 0 \\ 0 & \tilde{\Lambda}^{-1} \end{bmatrix} \mathcal{V}^T.$$

Thus

$$\mathcal{V}^T\mathcal{A}^\dagger\mathcal{V} = \begin{bmatrix} 0 & 0 \\ 0 & \tilde{\Lambda}^{-1} \end{bmatrix},$$

and

$$\begin{aligned}
\text{trace}(\tilde{\mathcal{Q}}\tilde{\Lambda}^{-1}) &= \text{trace}\left(\begin{bmatrix} 0 & 0 \\ 0 & \tilde{\mathcal{Q}} \end{bmatrix} \begin{bmatrix} 0 & 0 \\ 0 & \tilde{\Lambda}^{-1} \end{bmatrix}\right) \\
&= \text{trace}(\mathcal{V}^T \mathcal{Q} \mathcal{V} \mathcal{V}^T \mathcal{A}^\dagger \mathcal{V}) \\
&= \text{trace}(\mathcal{Q} \mathcal{A}^\dagger).
\end{aligned}$$

This proves statement (iii).

To prove (iv), the identities $\mathcal{A}^\dagger \mathcal{A} = I - \mathbb{1}\mathbb{1}^T/n$ and $\mathcal{A}^\dagger \mathbb{1} = 0$ can be employed to show that [32]

$$\mathcal{A}^\dagger = (\mathcal{A} - \mathbb{1}\mathbb{1}^T/n)^{-1} + \mathbb{1}\mathbb{1}^T/n,$$

which gives

$$\begin{aligned}
\text{trace}(\mathcal{Q} \mathcal{A}^\dagger) &= \text{trace}(\mathcal{Q}(\mathcal{A} - \mathbb{1}\mathbb{1}^T/n)^{-1} + \mathcal{Q}\mathbb{1}\mathbb{1}^T/n) \\
&= \text{trace}(\mathcal{Q}(\mathcal{A} - \mathbb{1}\mathbb{1}^T/n)^{-1}).
\end{aligned}$$

This proves statement (iv). The proof of the lemma is now complete.

Proof of Proposition 2

If Q_2 was positive definite and thus invertible, then replacing $(1/2) \text{trace}(Q_2^{1/2}(K + \mathbb{1}\mathbb{1}^T/n)^{-1}Q_2^{1/2})$ with $(1/2) \text{trace}(X)$ in the objective function of (14), subject to the linear matrix inequality (LMI) constraint

$$\begin{bmatrix} X & Q_2^{1/2} \\ Q_2^{1/2} & K + \mathbb{1}\mathbb{1}^T/n \end{bmatrix} \succeq 0,$$

would follow from a simple application of the Schur complement [40]. In particular, this would establish the positive definiteness, and thus the invertibility, of $K + \mathbb{1}\mathbb{1}^T/n$, and the optimal X that minimizes the objective subject to the LMI constraint would be given by $X = Q_2^{1/2}(K + \mathbb{1}\mathbb{1}^T/n)^{-1}Q_2^{1/2}$. However, since $Q_2\mathbb{1} = 0$ and therefore $Q_2^{1/2}$ is singular, we can only conclude from the above LMI that $K + \mathbb{1}\mathbb{1}^T/n$ is positive semidefinite. We next demonstrate that $K + \mathbb{1}\mathbb{1}^T/n$ is indeed invertible.

Using the unitary transformation \mathcal{V} from the proof of Lemma 1, the above LMI holds if and

only if

$$\begin{bmatrix} \mathcal{V}^T & 0 \\ 0 & \mathcal{V} \end{bmatrix} \begin{bmatrix} X & Q_2^{1/2} \\ Q_2^{1/2} & K + \mathbf{1}\mathbf{1}^T/n \end{bmatrix} \begin{bmatrix} \mathcal{V} & 0 \\ 0 & \mathcal{V} \end{bmatrix} = \begin{bmatrix} x_1 & x_0^T & 0 & 0 \\ x_0 & \tilde{X} & 0 & \tilde{Q} \\ 0 & 0 & 1 & 0 \\ 0 & \tilde{Q} & 0 & \tilde{K} \end{bmatrix} \succeq 0,$$

where the upper-left 2-by-2 block is the appropriately partitioned matrix $\mathcal{V}^T X \mathcal{V}$, the upper-right 2-by-2 block is the partitioned matrix $\mathcal{V}^T Q_2^{1/2} \mathcal{V}$ in which the zero structure follows from $Q_2^{1/2} \mathbf{1} = 0$, and the lower-right 2-by-2 block is the partitioned matrix $\mathcal{V}^T (K + \mathbf{1}\mathbf{1}^T/n) \mathcal{V}$ in which the zero structure follows from $K \mathbf{1} = 0$. Using a permutation of the rows and columns, the above LMI is equivalent to

$$\begin{bmatrix} x_1 & 0 & x_0^T & 0 \\ 0 & 1 & 0 & 0 \\ x_0^T & 0 & \tilde{X} & \tilde{Q} \\ 0 & 0 & \tilde{Q} & \tilde{K} \end{bmatrix} \succeq 0,$$

which in particular implies that

$$\begin{bmatrix} \tilde{X} & \tilde{Q} \\ \tilde{Q} & \tilde{K} \end{bmatrix} \succeq 0.$$

Since $Q_2^{1/2}$ is positive definite on $\mathbf{1}^\perp$ then $\tilde{Q} = \tilde{\mathcal{V}}^T Q_2^{1/2} \tilde{\mathcal{V}} \succ 0$. Thus $\tilde{K} = \tilde{\mathcal{V}}^T (K + \mathbf{1}\mathbf{1}^T/n) \tilde{\mathcal{V}} \succ 0$, and therefore $\mathcal{V}^T (K + \mathbf{1}\mathbf{1}^T/n) \mathcal{V} \succ 0$. This implies $(K + \mathbf{1}\mathbf{1}^T/n) \succ 0$, and $K + \mathbf{1}\mathbf{1}^T/n$ is invertible.

The term $\|W \circ K\|_{\ell_1}$ in the objective function can be replaced with $\text{trace}(\mathbf{1}\mathbf{1}^T Y)$, subject to the LMI constraint [41]

$$-Y \leq W \circ K \leq Y.$$

Finally, constraint $K \in \mathcal{L}$, which guarantees that K is the weighted Laplacian of a connected graph, is equivalent to the set of conditions

$$K = K^T, \quad M \circ K \leq 0, \quad K \mathbf{1} = 0, \quad K + \mathbf{1}\mathbf{1}^T/n \succ 0.$$

The first and last of these conditions are automatically fulfilled when K satisfies the LMI, and are therefore dropped from the formulation of the optimization problem. The proof of the proposition

is now complete.

Proof of Proposition 3

It is desired to compute variations in J that result from variations in K and H , with the variations in H occurring around the point $H = (1/L_0)I$.

Let $(H^{(0)}, K^{(0)})$, $H^{(0)} := (1/L_0)I$, denote the point at which the variations in J is to be computed. Note that $K^{(0)}$ can be *any* conductance matrix and is not necessarily equal to the optimal conductance matrix found from solving (15). Recall the Lyapunov equation in (5), or equivalently the equations (7)

$$\begin{aligned} HP_0^T + P_0H &= 0 \\ P_0K - P_1 + HP_2 &= 0 \\ KP_2 + P_2K - P_0 - P_0^T &= Q_2 + rK^2. \end{aligned}$$

Then small changes in H and K ,

$$\begin{aligned} H(\varepsilon) &= H^{(0)} + \varepsilon H^{(1)}, \\ K(\varepsilon) &= K^{(0)} + \varepsilon K^{(1)}, \end{aligned}$$

result in small changes in the matrices P_0, P_1, P_2 ,

$$P_i(\varepsilon) = P_i^{(0)} + \varepsilon P_i^{(1)} + O(\varepsilon^2), \quad i = 0, 1, 2.$$

We note that $H^{(1)}$ is a diagonal matrix, and that $K^{(1)}$ is such that $K(\varepsilon)$ is a legitimate conductance matrix; this, in particular, means that $K^{(1)}\mathbf{1} = 0$, $K^{(1)T} = K^{(1)}$.

Substituting into (7) the expansion around their nominal value of each of these matrices, and rearranging terms according to powers of ε , renders (up to first order in ε) the set of equations (19)-(20), where, in particular, $P_l^{(m)T} = P_l^{(m)}$ for $l = 1, 2$ and $m = 0, 1$.

$$O(1) : \begin{cases} H^{(0)}P_0^{(0)T} + P_0^{(0)}H^{(0)} = 0 \\ P_0^{(0)}K^{(0)} - P_1^{(0)} + H^{(0)}P_2^{(0)} = 0 \\ K^{(0)}P_2^{(0)} + P_2^{(0)}K^{(0)} - P_0^{(0)} - P_0^{(0)T} = Q_2 + rK^{(0)}K^{(0)} \end{cases} \quad (19)$$

$$O(\varepsilon) : \begin{cases} H^{(0)}P_0^{(1)T} + P_0^{(1)}H^{(0)} = -H^{(1)}P_0^{(0)T} - P_0^{(0)}H^{(1)} \\ P_0^{(1)}K^{(0)} - P_1^{(1)} + H^{(0)}P_2^{(1)} = -H^{(1)}P_2^{(0)} - P_0^{(0)}K^{(1)} \\ K^{(0)}P_2^{(1)} + P_2^{(1)}K^{(0)} - P_0^{(1)} - P_0^{(1)T} = rK^{(1)}K^{(0)} + rK^{(0)}K^{(1)} - K^{(1)}P_2^{(0)} - P_2^{(0)}K^{(1)} \end{cases} \quad (20)$$

It can be shown that the set of equations

$$\begin{aligned} P_0^{(0)} &= 0 \\ P_1^{(0)} &= H^{(0)}P_2^{(0)} \\ K^{(0)}P_2^{(0)} + P_2^{(0)}K^{(0)} &= Q_2 + rK^{(0)}K^{(0)} \end{aligned} \quad (21)$$

are equivalent to the $O(1)$ system of equations in (19). To see this, we first use that $H^{(0)}$ is a multiple of the identity and commutes with every matrix. The first equation in (19) thus becomes $P_0^{(0)} + P_0^{(0)T} = 0$, which implies that $P_0^{(0)}$ is an antisymmetric matrix. Taking the second equation in (19), transposing both sides and then subtracting from the original equation gives $P_0^{(0)}K^{(0)} - K^{(0)}P_0^{(0)T} = 0$. Invoking the antisymmetric property of $P_0^{(0)T}$, we obtain $K^{(0)}P_0^{(0)} + P_0^{(0)}K^{(0)} = 0$. Using a similar argument to that presented in the proof of Lemma 1(ii), any solution of this equation should be of the form $P_0^{(0)} = \varphi \mathbb{1} \mathbb{1}^T$ for some $\varphi \geq 0$. But since $P_0^{(0)}$ is antisymmetric φ can only have the value zero and thus $P_0^{(0)} = 0$. The rest of the equations in (21) now follow trivially. Furthermore, using (21) and $P_0^{(0)} = 0$ it also follows that the set of equations

$$\begin{aligned} P_0^{(1)} + P_0^{(1)T} &= 0 \\ P_1^{(1)} &= P_0^{(1)}K^{(0)} + H^{(0)}P_2^{(1)} + H^{(1)}P_2^{(0)} \\ K^{(0)}P_2^{(1)} + P_2^{(1)}K^{(0)} &= rK^{(1)}K^{(0)} + rK^{(0)}K^{(1)} - K^{(1)}P_2^{(0)} - P_2^{(0)}K^{(1)} \end{aligned} \quad (22)$$

are equivalent to the $O(\varepsilon)$ system of equations in (20).

In order to use Lemma 1 to derive an expression for $\text{trace}(P_2^{(1)})$, we have to demonstrate

that the vector $\mathbf{1}$ is in the null space of the matrix on the right side of the last equation in (22). We know from $K^{(0)}\mathbf{1} = K^{(1)}\mathbf{1} = 0$ that $(K^{(1)}K^{(0)} + K^{(0)}K^{(1)})\mathbf{1} = 0$. We next show that $(K^{(1)}P_2^{(0)} + P_2^{(0)}K^{(1)})\mathbf{1} = 0$. The last equation in (21), together with Lemma 1(iii), implies that $P_2^{(0)} = \tau\mathbf{1}\mathbf{1}^T + T$ for some $\tau \in \mathbb{R}$ and matrix T , $T\mathbf{1} = 0$. Thus

$$\begin{aligned} (K^{(1)}P_2^{(0)} + P_2^{(0)}K^{(1)})\mathbf{1} &= K^{(1)}(\tau\mathbf{1}\mathbf{1}^T + T)\mathbf{1} + P_2^{(0)}K^{(1)}\mathbf{1} \\ &= \tau K^{(1)}\mathbf{1}\mathbf{1}^T\mathbf{1} \\ &= 0, \end{aligned}$$

which is the desired result. We are now in position to apply Lemma 1.

The last equation in (22), together with Lemma 1(iii), implies

$$\begin{aligned} &\text{trace}(P_2^{(1)}) \\ &= p^{(1)} + (1/2) \text{trace}((rK^{(0)}K^{(1)} + rK^{(1)}K^{(0)} - K^{(1)}P_2^{(0)} - P_2^{(0)}K^{(1)})K^{(0)\dagger}) \\ &= p^{(1)} + (1/2) \text{trace}(2rK^{(1)} - K^{(1)}P_2^{(0)}K^{(0)\dagger} - P_2^{(0)}K^{(1)}K^{(0)\dagger}) \\ &= p^{(1)} + (1/2) \text{trace}((2rI - P_2^{(0)}K^{(0)\dagger} - K^{(0)\dagger}P_2^{(0)})K^{(1)}), \end{aligned}$$

where $p^{(1)} \in \mathbb{R}$ is independent of $K^{(0)}$, $K^{(1)}$, $P_2^{(0)}$, and we have used $K^{(0)}K^{(0)\dagger} = K^{(0)\dagger}K^{(0)} = I - \mathbf{1}\mathbf{1}^T/n$ and $K^{(1)}\mathbf{1} = 0$ to simplify the expressions. On the other hand, substituting $P_2^{(0)} = \tau\mathbf{1}\mathbf{1}^T + T$ into the last equation in (21), multiplying both sides from left and right by $K^{(0)\dagger}$, and simplifying, gives

$$\begin{aligned} (I - \mathbf{1}\mathbf{1}^T/n)(\tau\mathbf{1}\mathbf{1}^T + T)K^{(0)\dagger} + K^{(0)\dagger}(\tau\mathbf{1}\mathbf{1}^T + T)(I - \mathbf{1}\mathbf{1}^T/n) \\ &= TK^{(0)\dagger} + K^{(0)\dagger}T \\ &= (\tau\mathbf{1}\mathbf{1}^T + T)K^{(0)\dagger} + K^{(0)\dagger}(\tau\mathbf{1}\mathbf{1}^T + T) \\ &= K^{(0)\dagger}Q_2K^{(0)\dagger} + r(I - \mathbf{1}\mathbf{1}^T/n)(I - \mathbf{1}\mathbf{1}^T/n), \end{aligned}$$

or

$$P_2^{(0)}K^{(0)\dagger} + K^{(0)\dagger}P_2^{(0)} = K^{(0)\dagger}Q_2K^{(0)\dagger} + r(I - \mathbf{1}\mathbf{1}^T/n).$$

Using this equality in the equation for $\text{trace}(P_2^{(1)})$ leads to

$$\begin{aligned}\text{trace}(P_2^{(1)}) &= p^{(1)} + (1/2) \text{trace}((2rI - K^{(0)\dagger}Q_2K^{(0)\dagger} - r(I - \mathbb{1}\mathbb{1}^T/n))K^{(1)}) \\ &= p^{(1)} + (1/2) \text{trace}((rI - K^{(0)\dagger}Q_2K^{(0)\dagger})K^{(1)}),\end{aligned}$$

or equivalently

$$\delta J = \delta p + (1/2) \text{trace}((rI - K^\dagger Q_2 K^\dagger) \delta K),$$

where δp is independent of δK , but can be a function of δH . This implies, in particular, that

$$\nabla_K J = (1/2) (rI - K^\dagger Q_2 K^\dagger),$$

with the gradient being evaluated at the point $((1/L_0)I, K)$. The proof of the proposition is now complete.

REFERENCES

- [1] S. H. Strogatz, "From Kuramoto to Crawford: exploring the onset of synchronization in populations of coupled oscillators," *Physica D*, vol. 143, pp. 1–20, 2000.
- [2] F. Dorfler and F. Bullo, "Synchronization and transient stability in power networks and non-uniform Kuramoto oscillators," *SIAM Journal on Control and Optimization*, vol. 50, pp. 1616–1642, 2012.
- [3] F. Dorfler and F. Bullo, "Exploring synchronization in complex oscillator networks," in *Proceedings of the 51st IEEE Conference on Decision and Control*, 2012, pp. 7157–7170.
- [4] A. Mauroy, P. Sacré, and R. J. Sepulchre, "Kick synchronization versus diffusive synchronization," in *Proceedings of the 51st IEEE Conference on Decision and Control*, 2012, pp. 7171–7183.
- [5] M. Arcak, "Synchronization and pattern formation in diffusively coupled systems," in *Proceedings of the 51st IEEE Conference on Decision and Control*, 2012, pp. 7184–7192.
- [6] F. Dorfler, M. Chertkov, and F. Bullo, "Synchronization assessment in power networks and coupled oscillators," in *Proceedings of the 51st IEEE Conference on Decision and Control*, 2012, pp. 4998–5003.
- [7] F. Dorfler and F. Bullo, "On the critical coupling strength for Kuramoto oscillators," in *Proceedings of the 2011 American Control Conference*, 2011, pp. 3239–3244.
- [8] A. Jadbabaie, N. Motesharraf, and M. Barahona, "On the stability of the Kuramoto model of coupled nonlinear oscillators," in *Proceedings of the 2004 American Control Conference*, 2004, pp. 4296–4301.
- [9] W. Ren, "Synchronization of coupled harmonic oscillators with local interaction," *Automatica*, vol. 44, pp. 3195–3200, 2008.
- [10] S. H. Strogatz, "TED: Steven Strogatz on sync," http://www.ted.com/talks/steven_strogatz_on_sync.html, 2004.
- [11] B. Bamieh, F. Paganini, and M. A. Dahleh, "Distributed control of spatially invariant systems," *IEEE Transactions on Automatic Control*, vol. 47, no. 7, pp. 1091–1107, 2002.

- [12] G. A. de Castro and F. Paganini, “Convex synthesis of localized controllers for spatially invariant system,” *Automatica*, vol. 38, pp. 445–456, 2002.
- [13] P. G. Voulgaris, G. Bianchini, and B. Bamieh, “Optimal H^2 controllers for spatially invariant systems with delayed communication requirements,” *Systems and Control Letters*, vol. 50, pp. 347–361, 2003.
- [14] R. D’Andrea and G. E. Dullerud, “Distributed control design for spatially interconnected systems,” *IEEE Transactions on Automatic Control*, vol. 48, no. 9, pp. 1478–1495, 2003.
- [15] C. Langbort, R. S. Chandra, and R. D’Andrea, “Distributed control design for systems interconnected over an arbitrary graph,” *IEEE Transactions on Automatic Control*, vol. 49, no. 9, pp. 1502–1519, September 2004.
- [16] B. Bamieh and P. G. Voulgaris, “A convex characterization of distributed control problems in spatially invariant systems with communication constraints,” *Systems and Control Letters*, vol. 54, pp. 575–583, 2005.
- [17] M. Rotkowitz and S. Lall, “A characterization of convex problems in decentralized control,” *IEEE Transactions on Automatic Control*, vol. 51, no. 2, pp. 274–286, 2006.
- [18] A. Rantzer, “A separation principle for distributed control,” in *Proceedings of the 45th IEEE Conference on Decision and Control*, 2006, pp. 3609–3613.
- [19] N. Motee and A. Jadbabaie, “Optimal control of spatially distributed systems,” *IEEE Transactions on Automatic Control*, vol. 53, no. 7, pp. 1616–1629, Aug. 2008.
- [20] F. Borrelli and T. Keviczky, “Distributed LQR design for identical dynamically decoupled systems,” *IEEE Transactions on Automatic Control*, vol. 53, no. 8, pp. 1901–1912, Sept. 2008.
- [21] M. Fardad and M. R. Jovanović, “Design of optimal controllers for spatially invariant systems with finite communication speed,” *Automatica*, vol. 47, pp. 880–889, 2011.
- [22] J. Swigart and S. Lall, “An explicit state-space solution for a decentralized two-player optimal linear-quadratic regulator,” in *Proceedings of the 2010 American Control Conference*, 2010, pp. 6385–6390.
- [23] L. Lessard and S. Lall, “Optimal controller synthesis for the decentralized two-player problem with output feedback,” in *Proceedings of the 2012 American Control Conference*, 2012, pp. 6314–6321.
- [24] P. Shah and P. A. Parrilo, “ H_2 optimal decentralized control over posets: A state space solution for state-feedback,” in *Proceedings of the 49th IEEE Conference on Decision and Control*, 2010, pp. 6722–6727.
- [25] P. Shah and P. A. Parrilo, “ H_2 -optimal decentralized control over posets: A state-space solution for state-feedback,” *IEEE Trans. Automat. Control*, 2011, submitted; also arXiv:1111.1498v1.
- [26] F. Lin, M. Fardad, and M. R. Jovanović, “Augmented Lagrangian approach to design of structured optimal state feedback gains,” *IEEE Transactions on Automatic Control*, vol. 56, pp. 2923–2929, 2011.
- [27] F. Lin, M. Fardad, and M. R. Jovanović, “Optimal control of vehicular formations with nearest neighbor interactions,” *IEEE Transactions on Automatic Control*, vol. 57, pp. 2203–2218, 2012.
- [28] M. Fardad, F. Lin, and M. R. Jovanović, “On the optimal design of structured feedback gains for interconnected systems,” in *Proceedings of the 48th IEEE Conference on Decision and Control*, 2009, pp. 978–983.
- [29] F. Lin, M. Fardad, and M. R. Jovanović, “Design of optimal sparse feedback gains via the alternating direction method of multipliers,” *IEEE Transactions on Automatic Control*, 2013, conditionally accepted; also arXiv:1111.6188v2.
- [30] M. Fardad, F. Lin, and M. R. Jovanović, “On the optimal synchronization of oscillator networks via sparse interconnection graphs,” in *Proceedings of the 2012 American Control Conference*, 2012, pp. 4777–4782.
- [31] M. Fardad, F. Lin, and M. R. Jovanović, “Sparsity-promoting optimal control for a class of distributed systems,” in *Proceedings of the 2011 American Control Conference*, 2011, pp. 2050–2055.

- [32] A. Ghosh, S. Boyd, and A. Saberi, “Minimizing the effective resistance of a graph,” *SIAM Review*, vol. 50, no. 1, pp. 37–66, 2008.
- [33] F. Dorfler and F. Bullo, “Kron reduction of graphs with applications to electrical networks,” *IEEE Transactions on Circuits and Systems I*, 2013, to appear.
- [34] K. Zhou, J. Doyle, and K. Glover, *Robust and Optimal Control*. Prentice Hall, 1996.
- [35] E. J. Candès, J. Romberg, and T. Tao, “Stable signal recovery from incomplete and inaccurate measurements,” *Communications on Pure and Applied Mathematics*, vol. 59, no. 8, pp. 1207–1223, 2006.
- [36] E. J. Candès, M. B. Wakin, and S. P. Boyd, “Enhancing sparsity by reweighted ℓ_1 minimization,” *Journal of Fourier Analysis and Applications*, vol. 14, pp. 877–905, 2008.
- [37] M. Grant and S. Boyd, “CVX: Matlab software for disciplined convex programming, version 1.21,” <http://cvxr.com/cvx/>, 2011.
- [38] M. Grant and S. Boyd, “Graph implementations for nonsmooth convex programs,” in *Recent Advances in Learning and Control*, ser. Lecture Notes in Control and Information Sciences, V. Blondel, S. Boyd, and H. Kimura, Eds. Springer-Verlag Limited, 2008, pp. 95–110.
- [39] B. Bamieh and M. Dahleh, “Exact computation of traces and H^2 norms for a class of infinite-dimensional problems,” *IEEE Transactions on Automatic Control*, vol. 48, no. 4, April 2003.
- [40] S. Boyd and L. El Ghaoui, *Linear Matrix Inequalities in System and Control Theory*. SIAM, 1994.
- [41] S. Boyd and L. Vandenberghe, *Convex Optimization*. Cambridge University Press, 2004.