

# TAUT FOLIATIONS IN SURFACE BUNDLES WITH MULTIPLE BOUNDARY COMPONENTS

TEJAS KALELKAR AND RACHEL ROBERTS

ABSTRACT. Let  $M$  be a fibered 3-manifold with multiple boundary components. We show that the fiber structure of  $M$  transforms to closely related transversely oriented taut foliations realizing all rational multislopes in some open neighborhood of the multislope of the fiber. Each such foliation extends to a taut foliation in the closed 3-manifold obtained by Dehn filling along its boundary multislope. The existence of these foliations implies that certain contact structures are weakly symplectically fillable.

## 1. INTRODUCTION

Any closed, orientable 3-manifold can be realized by Dehn filling a 3-manifold which is fibered over  $S^1$  [1, 27]. In other words, any closed oriented 3-manifold can be realized by Dehn filling a 3-manifold  $M_0$ , where  $M_0$  has the form of a mapping torus

$$M_0 = S \times [0, 1] / \sim,$$

where  $S$  is a compact orientable surface with nonempty boundary and  $\sim$  is an equivalence relation given by  $(x, 1) \sim (h(x), 0)$  for some orientation preserving homeomorphism  $h : S \rightarrow S$  which fixes the components of  $\partial S$  setwise. Although we shall not appeal to this fact in this paper, it is interesting to note that it is possible to assume that  $h$  is pseudo-Anosov [6] and hence  $M_0$  is hyperbolic [41]. It is also possible to assume that  $S$  has positive genus. Any nonorientable closed 3-manifold admits a double cover of this form.

Taut codimension one foliations are topological objects which have proved very useful in the study of 3-manifolds. The problem of determining when a 3-manifold contains a taut foliation appears to be a very difficult one. A complete classification exists for Seifert fibered manifolds [3, 9, 17, 28] but relatively little is known for the case of hyperbolic 3-manifolds. There

---

*Date:* September 15, 2013.

*2000 Mathematics Subject Classification.* Primary 57M50.

*Key words and phrases.* Dehn filling, taut foliation, fibered 3-manifold, contact structure, open book decomposition.

are many partial results demonstrating existence (see, for example, [7, 10, 11, 12, 23, 25, 35, 36, 37]) and partial results demonstrating nonexistence [18, 19, 20, 38]. In this paper, we investigate the existence of taut codimension one foliations in closed orientable 3-manifolds by first constructing taut codimension one foliations in corresponding mapping tori  $M_0$ . In contrast with the work in [36, 37], we consider the case that the boundary of  $M_0$  is not connected. We obtain the following results. Precise definitions will follow in Section 2.

**Theorem 1.1.** *Given an orientable, fibered compact 3-manifold, a fibration with fiber surface of positive genus can be modified to yield transversely oriented taut foliations realizing a neighborhood of rational boundary multislopes about the boundary multislope of the fibration.*

As an immediate corollary for closed manifolds we therefore have:

**Corollary 1.2.** *Let  $M = \widehat{M}_0(r^j)$  be the closed manifold obtained from  $M_0$  by Dehn filling  $M_0$  along the multicurve with rational multislope  $(r^j)_{j=1}^k$ . When  $(r^j)$  is sufficiently close to the multislope of the fibration,  $M$  admits a transversely oriented taut foliation.*

Dehn filling  $M_0$  along the slope of the fiber gives a mapping torus of a closed surface with the fibration as the obvious taut foliation. The above corollary shows that Dehn filling  $M_0$  along slopes sufficiently close to the multislope of the fiber also gives a closed manifold with a taut foliation.

When the surgery coefficients  $r^j$  are all meridians, the description of  $M$  as a Dehn filling of  $M_0$  gives an open book decomposition  $(S, h)$  of  $M$ . The foliations of Corollary 1.2 can be approximated by a pair of contact structures, one positive and one negative, and both naturally related to the contact structure  $\xi_{(S,h)}$  compatible with the open book decomposition  $(S, h)$  [8, 22]. It follows that the contact structure  $\xi_{(S,h)}$  is weakly symplectically fillable.

**Corollary 1.3.** *Let  $M$  have open book decomposition  $(S, h)$ . Then  $M$  is obtained by Dehn filling  $M_0$  along the multicurve with rational multislope  $(r^j)_{j=1}^k$ , where the  $r^j$  are all meridians. When  $(r^j)$  is sufficiently close to the multislope of the fibration,  $\xi_{(S,h)}$  is weakly symplectically fillable and hence universally tight.*

It is very natural to ask whether the qualifier ‘sufficiently close’ can be made precise.

Honda, Kazez, Matic[16] proved that when an open book with connected binding has monodromy with fractional Dehn twist coefficient  $c$  at least one then it supports a contact structure which is close to a co-orientable taut

foliation. Note that  $c \geq 1$  is sufficient but not always necessary to guarantee that  $\xi_{(S,h)}$  is close to a co-orientable taut foliation.

For an open book with multiple binding components, there is no such global lower bound on the fractional Dehn twist coefficients sufficient to guarantee that  $\xi_{(S,h)}$  is close to a co-orientable taut foliation. This was shown by Baldwin and Etnyre[2], who constructed a sequence of open books with arbitrarily large fractional Dehn twist coefficients and disconnected binding that support contact structures which are not deformations of a taut foliation. So we can not expect to obtain a neighborhood around the slope of the fiber which would satisfy our criteria of ‘sufficiently close’ for every open book decomposition. At the end of the paper, in Section 4, we explicitly compute a neighborhood around the multislope of the fiber realizable by our construction for the Baldwin-Etnyre examples.

## 2. PRELIMINARIES

In this section we introduce basic definitions and fix conventions used in the rest of the paper.

**2.1. Foliations.** Roughly speaking, a codimension-1 foliation  $\mathcal{F}$  of a 3-manifold  $M$  is a disjoint union of injectively immersed surfaces such that  $(M, \mathcal{F})$  looks locally like  $(\mathbb{R}^3, \mathbb{R}^2 \times \mathbb{R})$ .

**Definition 2.1.** Let  $M$  be a closed  $C^\infty$  3-manifold and let  $r$  be a non-negative integer or infinity. A  $C^r$  *codimension one foliation*  $\mathcal{F}$  of (or in)  $M$  is a union of disjoint connected surfaces  $L_i$ , called the *leaves of  $\mathcal{F}$* , in  $M$  such that:

- (1)  $\cup_i L_i = M$ , and
- (2) there exists a  $C^r$  atlas  $\mathcal{A}$  on  $M$  which contains all  $C^\infty$  charts and with respect to which  $\mathcal{F}$  satisfies the following local product structure:
  - for every  $p \in M$ , there exists a coordinate chart  $(U, (x, y, z))$  in  $\mathcal{A}$  about  $p$  such that  $U \approx \mathbb{R}^3$  and the restriction of  $\mathcal{F}$  to  $U$  is the union of planes given by  $z = \text{constant}$ .

When  $r = 0$ , require also that the tangent plane field  $T\mathcal{F}$  be  $C^0$ .

A *taut* foliation [10] is a codimension-1 foliation of a 3-manifold for which there exists a transverse simple closed curve that has nonempty intersection with each leaf of the foliation. Although every 3-manifold contains a codimension-1 foliation [26, 29, 45], it is not true that every 3-manifold contains a codimension-1 taut foliation. In fact, the existence of a taut foliation in a closed orientable 3-manifold has important topological consequences for the manifold. For example, if  $M$  is a closed, orientable 3-manifold that has a taut foliation with no sphere leaves then  $M$  is covered by

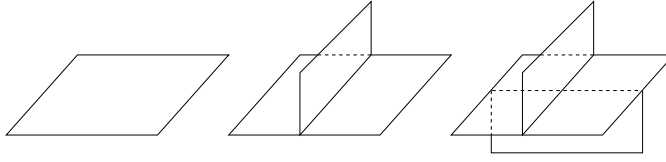

FIGURE 1. Local model of a standard spine

$\mathbb{R}^3$  [33],  $M$  is irreducible [40] and has an infinite fundamental group [15]. In fact, its fundamental group acts nontrivially on interesting 1-dimensional objects (see, for example, [43, 4] and [33, 38]). Moreover, taut foliations can be perturbed to weakly symplectically fillable contact structures [8] and hence can be used to obtain Heegaard-Floer information [32].

**2.2. Multislopes.** Let  $F$  be a compact oriented surface of positive genus and with nonempty boundary consisting of  $k$  components. Let  $h$  be an orientation preserving homeomorphism of  $F$  which fixes each boundary component pointwise. Let  $M = F \times I / (x, 1) \sim (h(x), 0)$  and denote the  $k$  (toral) boundary components of  $\partial M$  by  $T^1, T^2, \dots, T^k$ .

We use the given surface bundle structure on  $M$  to fix a coordinate system on each of the boundary tori as follows. (See, for example, Section 9.G of [39] for a definition and description of coordinate system.) For each  $j$  we choose as longitude  $\lambda^j = \partial F \cap T^j$ , with orientation inherited from the orientation of  $F$ . For each  $j$ , we then fix as meridian  $\mu_j$  an oriented simple closed curve dual to  $\lambda_j$ . Although, as described in [22, 37], it is possible to use the homeomorphism  $h$  to uniquely specify such simple closed curves  $\mu_j$ , we choose not to do so in this paper as all theorem statements are independent of the choice of meridional multislope.

We say a taut foliation  $\mathcal{F}$  in  $M$  realizes boundary multislope  $(m^j)_{j=1}^k$  if for each  $j$ ,  $1 \leq j \leq k$ ,  $\mathcal{F} \cap T^j$  is a foliation of  $T^j$  of slope  $m^j$  in the chosen coordinate system of  $T^j$ .

### 2.3. Spines and Branched surfaces.

**Definition 2.2.** A *standard spine* [5] is a space  $X$  locally modeled on one of the spaces of Figure 1. The *critical locus* of  $X$  is the 1-complex of points of  $X$  where the spine is not locally a manifold.

**Definition 2.3.** A *branched surface* ([44]; see also [30, 31]) is a space  $B$  locally modeled on the spaces of Figure 2. The *branching locus*  $L$  of  $B$  is the 1-complex of points of  $B$  where  $B$  is not locally a manifold. The components of  $B \setminus L$  are called the *sectors* of  $B$ . The points where  $L$  is not locally a manifold are called *double points* of  $L$ .

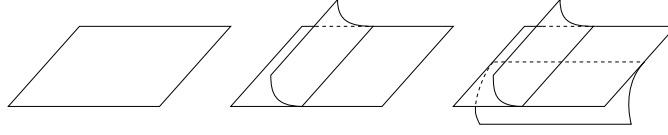

FIGURE 2. Local model of a branched surface

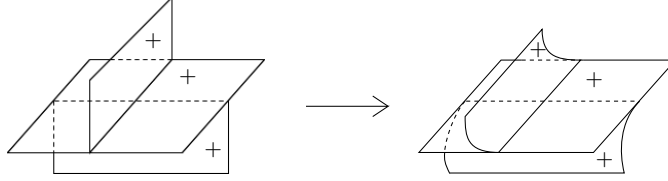

FIGURE 3. Oriented spine to oriented branched surface

A standard spine  $X$  together with an orientation in a neighborhood of the critical locus determines a branched surface  $B$  in the sense illustrated in Figure 3.

**Example 2.4.** Let  $F_0 := F \times \{0\}$  be a fiber of  $M = F \times I / (x, 1) \sim (h(x), 0)$ . Let  $\alpha_i$ ,  $1 \leq i \leq k$ , be pairwise disjoint, properly embedded arcs in  $F_0$ , and set  $D_i = \alpha_i \times I$  in  $M$ . Isotope the image arcs  $h(\alpha_i)$  as necessary so that the intersection  $(\cup \alpha_i) \cap (\cup h(\alpha_i))$  is transverse and minimal. Assign an orientation to  $F$  and to each  $D_i$ . Then  $X = F_0 \cup_i D_i$  is a transversely oriented spine. We will denote by  $B = \langle F; \cup_i D_i \rangle$  the transversely oriented branched surface associated with  $X = F_0 \cup_i D_i$ .

Similarly,  $\langle \cup_i F_i; \cup_{i,j} D_i^j \rangle$  will denote the transversely oriented branched surface associated to the transversely oriented standard spine

$$X = F_0 \cup F_1 \cup \dots \cup F_{n-1} \cup_{i,j} D_i^j$$

where  $F_i = F \times \{i/n\}$  and  $D_i^j = \alpha_i^j \times [\frac{i}{n}, \frac{i+1}{n}]$  for some set of arcs  $\alpha_i^j$  properly embedded in  $F$  so that the intersection  $(\cup_j \alpha_{i-1}^j) \cap (\cup_j \alpha_i^j)$  is transverse and minimal.

**Definition 2.5.** A lamination carried by a branched surface  $B$  in  $M$  is a closed subset  $\lambda$  of an  $I$ -fibered regular neighborhood  $N(B)$  of  $B$ , such that  $\lambda$  is a disjoint union of injectively immersed 2-manifolds (called leaves) that intersect the  $I$ -fibers of  $N(B)$  transversely.

**2.4. Laminar branched surfaces.** In [23, 24], Li introduces the fundamental notions of sink disk and half sink disk.

**Definition 2.6.** [23, 24] Let  $B$  be a branched surface in a 3-manifold  $M$ . Let  $L$  be the branching locus of  $B$  and let  $X$  denote the union of double points of  $L$ . Associate to each component of  $L \setminus X$  a vector (in  $B$ ) pointing

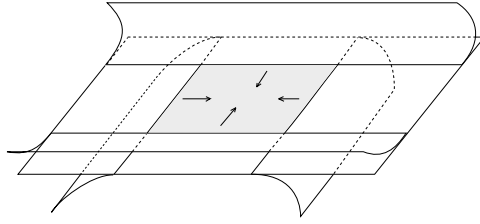

FIGURE 4. A sink disk

in the direction of the cusp. A *sink disk* is a disk branch sector  $D$  of  $B$  for which the branch direction of each component of  $(L \setminus X) \cap \bar{D}$  points into  $D$  (as shown in Figure 4). A *half sink disk* is a sink disk which has nonempty intersection with  $\partial M$ .

Sink disks and half sink disks play a key role in Li's notion of laminar branched surface.

**Definition 2.7.** (Definition 1.3, [23]) Let  $D_1$  and  $D_2$  be the two disk components of the horizontal boundary of a  $D^2 \times I$  region in  $M \setminus \text{int}(N(B))$ . If the projection  $\pi : N(B) \rightarrow B$  restricted to the interior of  $D_1 \cup D_2$  is injective, i.e, the intersection of any  $I$ -fiber of  $N(B)$  with  $\text{int}(D_1) \cup \text{int}(D_2)$  is either empty or a single point, then we say that  $\pi(D_1 \cup D_2)$  forms a *trivial bubble* in  $B$ .

**Definition 2.8.** (Definition 1.4, [23]) A branched surface  $B$  in a closed 3-manifold  $M$  is called a *laminar branched surface* if it satisfies the following conditions:

- (1)  $\partial_h N(B)$  is incompressible in  $M \setminus \text{int}(N(B))$ , no component of  $\partial_h N(B)$  is a sphere and  $M \setminus B$  is irreducible.
- (2) There is no monogon in  $M \setminus \text{int}(N(B))$ ; i.e., no disk  $D \subset M \setminus \text{int}(N(B))$  with  $\partial D = D \cap N(B) = \alpha \cup \beta$ , where  $\alpha \subset \partial_v N(B)$  is in an interval fiber of  $\partial_v N(B)$  and  $\beta \subset \partial_h N(B)$
- (3) There is no Reeb component; i.e.,  $B$  does not carry a torus that bounds a solid torus in  $M$ .
- (4)  $B$  has no trivial bubbles.
- (5)  $B$  has no sink disk or half sink disk.

Gabai and Oertel introduced essential branched surfaces in [13] and proved that any lamination fully carried by an essential branched surface is an essential lamination and conversely any essential lamination is fully carried by an essential branched surface. In practice, to check if a manifold has an essential lamination, the tricky part often is to verify that a candidate branched surface does in fact fully carry a lamination. Li [23] uses laminar branched surfaces to relax this requirement and prove the following:

**Theorem 2.9.** (Theorem 1, [23]) *Suppose  $M$  is a closed and orientable 3-manifold. Then*

- (a) *Every laminar branched surface in  $M$  fully carries an essential lamination.*
- (b) *Any essential lamination in  $M$  that is not a lamination by planes is fully carried by a laminar branched surface.*

In [24], Li notices that if a branched surface has no half sink disk, then it can be arbitrarily split in a neighborhood of its boundary train track without introducing any sink disk (or half sink disk). He is therefore able to conclude the following.

**Theorem 2.10.** (Theorem 2.2, [24]) *Let  $M$  be an irreducible and orientable 3-manifold whose boundary is a union of incompressible tori. Suppose  $B$  is a laminar branched surface and  $\partial M \setminus \partial B$  is a union of bigons. Then, for any multislope  $(s_1, \dots, s_k) \in (\mathbb{Q} \cup \{\infty\})^k$  that can be realized by the train track  $\partial B$ , if  $B$  does not carry a torus that bounds a solid torus in  $\widehat{M}(s_1, \dots, s_k)$ , then  $B$  fully carries a lamination  $\lambda_{(s_1, \dots, s_k)}$  whose boundary consists of the multislope  $(s_1, \dots, s_k)$  and  $\lambda_{(s_1, \dots, s_k)}$  can be extended to an essential lamination in  $\widehat{M}(s_1, \dots, s_k)$ .*

We note that in [24], Li states Theorem 2.2 only for the case that  $\partial M$  is connected. However, as Li has observed and is easily seen, his proof extends immediately to the case that  $\partial M$  consists of multiple toral boundary components. Key is the fact that splitting  $B$  open, to a branched surface  $B'$  say, in a neighborhood of its boundary so that  $\partial B'$  consists of multislopes  $(s_1, \dots, s_k)$ , does not introduce sink disks. Therefore, capping  $B'$  off to  $\widehat{B}'$  yields a laminar branched surface in  $\widehat{M}(s_1, \dots, s_k)$ .

**2.5. Good oriented sequence of arcs.** In this section we introduce some definitions that will be used in the rest of the paper.

**Definition 2.11.** Let  $(\alpha^1, \dots, \alpha^k)$  be a tuple of pairwise disjoint simple arcs properly embedded in  $F$  with  $\partial\alpha^j \subset T^j$ . Such a tuple will be called *parallel* if  $F \setminus \{\alpha^1, \dots, \alpha^k\}$  has  $k$  components,  $k - 1$  of which are annuli  $\{A^j\}$  with  $\partial A^j \supset \{\alpha^j, \alpha^{j+1}\}$  and one of which is a surface  $S$  of genus  $g - 1$  with  $\partial S \supset \{\alpha^1, \alpha^k\}$ . Furthermore all  $\alpha^j$  are oriented in parallel, i.e., the orientation of  $\partial A^j$  agrees with  $\{-\alpha^j, \alpha^{j+1}\}$  and the orientation of  $\partial S$  agrees with  $\{-\alpha^k, \alpha^1\}$ . Note that, in particular, each  $\alpha^j$  is non-separating. See Figure 5 for an example of a parallel tuple.

**Definition 2.12.** A pair of tuples  $(\alpha^i)_{i=1\dots k}$  and  $(\beta^j)_{j=1\dots k}$  will be called *good* if both are parallel tuples and  $\alpha^i$  and  $\beta^j$  have exactly one (interior) point of intersection when  $i \neq j$  while  $\alpha^i$  is disjoint from  $\beta^j$  when  $i = j$ .

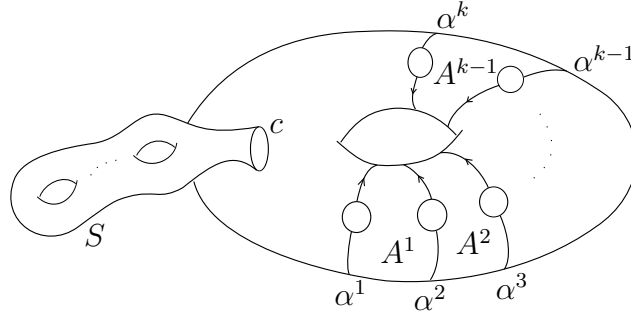
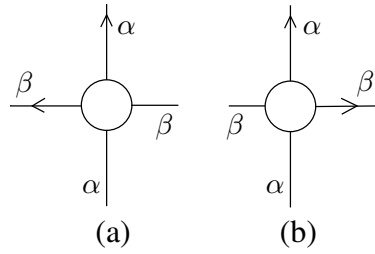
FIGURE 5. A Parallel tuple  $(\alpha^i)$  on the surface  $F$ FIGURE 6. A pair of arcs  $(\alpha, \beta)$  in position (a) is called negatively oriented, while a pair  $(\alpha, \beta)$  in position (b) is called positively oriented

A sequence of parallel tuples

$$\sigma = ((\alpha_0^1, \alpha_0^2, \dots, \alpha_0^k), (\alpha_1^1, \alpha_1^2, \dots, \alpha_1^k), \dots, (\alpha_n^1, \alpha_n^2, \dots, \alpha_n^k))$$

also shortened to

$$((\alpha_0^j), (\alpha_1^j), \dots, (\alpha_n^j))$$

or

$$(\alpha_0^j) \xrightarrow{\sigma} (\alpha_n^j)$$

will be called *good* if for each fixed  $j$ ,  $1 \leq j \leq k$ , the pair  $((\alpha_i^j), (\alpha_{i+1}^j))$  is good.

**Definition 2.13.** We say a good pair  $((\alpha^j), (\beta^j))$  is *positively oriented* if for each  $j \in \{1, \dots, k\}$  a neighborhood of the  $j$ -th boundary component in  $F$  is as shown in Figure 6 (b). Similarly we say a good pair  $((\alpha^j), (\beta^j))$  is *negatively oriented* if for each  $j \in \{1, \dots, k\}$  a neighborhood of the  $j$ -th boundary component in  $F$  is as shown in Fig 6 (a).

We say a good sequence  $\sigma = ((\alpha_0^j), (\alpha_1^j), \dots, (\alpha_n^j))$  is *positively oriented* if each pair  $((\alpha_i^j), (\alpha_{i+1}^j))$  is positively oriented. Similarly we say  $\sigma = ((\alpha_1^j), (\alpha_2^j), \dots, (\alpha_n^j))$  is *negatively oriented* if each pair  $((\alpha_i^j), (\alpha_{i+1}^j))$  is negatively oriented. We say the sequence  $\sigma$  is oriented if it is positively



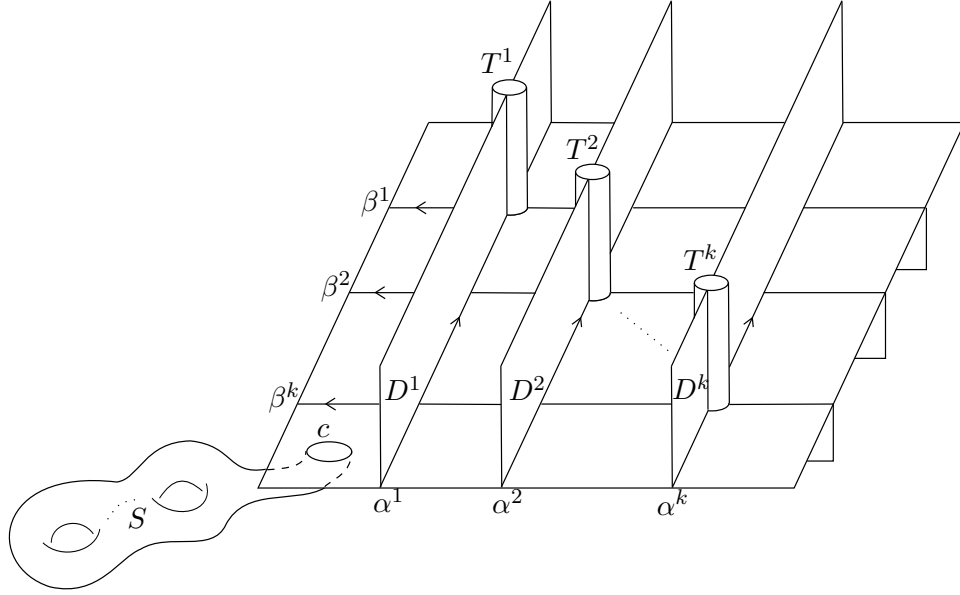

FIGURE 7. Neighborhood of  $F$  with a good negatively oriented pair  $((\alpha^j), (\beta^j))$  in the oriented spine  $X$

or negatively oriented. See Figure 7 for an example of a negatively oriented good pair in  $F$ .

**2.6. Preferred generators.** Let

$$\mathcal{H}_{g,k} = \{\eta_1, \eta_2, \dots, \eta_{2g-2+k}, \gamma_{12}, \gamma_{24}, \gamma_{46}, \gamma_{68}, \dots, \gamma_{2g-4, 2g-2}, \beta, \beta_1, \beta_2, \dots, \beta_{g-1}, \delta_1, \delta_2, \dots, \delta_{k-1}\}$$

be the curves on  $F$  as shown in Figure 8. Then combining Proposition 1 and Theorem 1 of Gervais [14] the mapping class group  $MCG(F, \partial F)$  of  $F$  (fixing boundary) is generated by Dehn twists about curves in  $\mathcal{H}_{g,k}$ .

**Theorem (Gervais).** *The mapping class group  $MCG(F, \partial F)$  of  $F$  is generated by Dehn twists about the curves in  $\mathcal{H}_{g,k}$ .*

As Dehn twists about  $\delta_i$  are isotopic to the identity via an isotopy that does not fix the boundary, we have the following obvious corollary:

**Corollary 2.14.** *The mapping class group  $MCG(F)$  of  $F$  (not fixing the boundary pointwise) is generated by Dehn twists about the curves in*

$$\mathcal{H}'_{g,k} = \mathcal{H}_{g,k} \setminus \{\delta_1, \dots, \delta_{k-1}\}$$

### 3. MAIN THEOREM

**Definition 3.1.** Let  $(\alpha^1, \dots, \alpha^k)$  be a parallel tuple in  $F$ . Orient  $F$  so that the normal vector  $\hat{n}$  induced by the orientation of  $M$  points in the direction

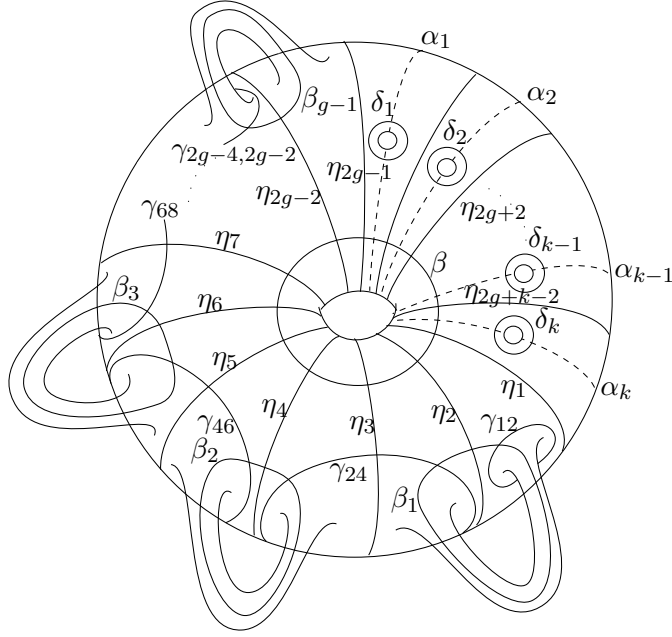

FIGURE 8. Generators of the Mapping Class Group

of increasing  $t \in [0, 1]$ . Let  $D^j = \alpha^j \times [0, 1]$  in  $M_h$  with the orientation induced by orientations of  $\alpha^j$  and  $F$ ; i.e., if  $v^j$  is tangent to  $\alpha^j$  then  $(v^j, \hat{n})$  gives the orientation of  $D^j$ . Let  $X = F \cup_j D^j$  be an oriented standard spine and  $B_\alpha = \langle F; \cup_j D^j \rangle$  the transversely oriented branched surface associated with  $X$ .

Notice that the multislope of the fibration is  $\bar{0}$ . In order to prove Theorem 1.1 we shall prove the following:

**Theorem 3.2.** *There is an open neighborhood  $\mathcal{U}$  of  $\bar{0} \in \mathbb{R}^k$  such that for each point  $(m^1, \dots, m^k) \in \mathcal{U} \cap \mathbb{Q}^k$ , there exists a lamination carried by  $B_\alpha$  with boundary multislope  $(m^j)$ . These laminations extend to taut foliations which also intersect the boundary in foliations with multislope  $(m^j)$ .*

This gives us the following corollary for closed manifolds.

**Corollary 3.3.** *Let  $\widehat{M}(r^j)$  denote the closed manifold obtained from  $M$  by a Dehn filling along a multicurve with rational multislope  $(r^j)_{j=1}^k$ . For each tuple  $(r^j) \in \mathcal{U} \cap \mathbb{Q}^k$ , the closed manifold  $\widehat{M}(r^j)$  also has a transversely oriented taut foliation.*

The proof of Theorem 3.2 is outlined below with details worked out in the mentioned lemmas.

*Proof.* In Lemma 3.4 we shall show that there is a good positively oriented sequence  $(\alpha_0^j) \rightarrow (h^{-1}(\alpha_0^j))$ , or equivalently from  $(h(\alpha_n^j)) \rightarrow (\alpha_n^j)$ . In Lemma 3.6 we shall show that whenever there exists such a positive sequence there is a splitting of the branched surface  $B_\alpha$  to a branched surface  $B_\sigma$  that is laminar and that therefore carries laminations realizing every multislope in some open neighborhood of  $\bar{0} \in \mathbb{R}^k$ . And finally in Lemma 3.8 we show that these laminations extend to taut foliations on all of  $M$ .  $\square$

**Lemma 3.4.** *Let  $(\alpha^j)$  be a parallel tuple in  $F$  and let  $h \in \text{Aut}^+(F)$ . Then there is a good positively oriented sequence  $(\alpha^j) \xrightarrow{\sigma} (h(\alpha^j))$ .*

*Proof.* By Corollary 2.14 to Gervais' Theorem,  $h \sim h_m h_{m-1} \dots h_2 h_1$  for twists  $h_i$  about curves in  $\mathcal{H}'_{g,k}$ . Set  $h' = h_m h_{m-1} \dots h_2 h_1$ , and notice that  $M_h = M_{h'}$ .

By changing the handle decomposition of  $F$  as necessary, we may assume that the parallel tuple  $(\alpha^j)$  is as shown in Figure 8. Let  $b$  denote the Dehn twist about  $\beta \in \mathcal{H}'_{g,k}$ . Notice that any  $h_i$  in the factorization of  $h'$  is either  $b$ ,  $b^{-1}$ , or a twist about a curve disjoint from all components of  $\alpha^j$ . Thus  $((\alpha^j), (h_i(\alpha^j)))$  is either a good positive pair, a good negative pair, or a pair of equal tuples.

Now if  $((\alpha^j), (\beta^j))$  is a good pair then so is  $((h_i(\alpha^j)), (h_i(\beta^j)))$ ; therefore each of the pairs

$$((\alpha^j), (h_m(\alpha^j))), ((h_m(\alpha^j)), (h_m h_{m-1}(\alpha^j))), ((h_m h_{m-1}(\alpha^j)), (h_m h_{m-1} h_{m-2}(\alpha^j))), \dots, ((h_m h_{m-1} \dots h_2(\alpha^j)), (h_m h_{m-1} \dots h_2 h_1(\alpha^j) = h(\alpha^j)))$$

is either a good oriented pair or a pair of equal tuples.

If at least one of the  $h_i$  is  $b$  or  $b^{-1}$  then ignoring the equal tuples, we get a good oriented sequence  $((\alpha_0^j), (\alpha_1^j), \dots, (\alpha_{n-1}^j), (\alpha_n^j) = h((\alpha_0^j)))$  or  $(\alpha^j) \xrightarrow{\sigma} (h(\alpha^j))$  as required. The length of this sequence is equal to the number of times  $h_i$  equals  $b$  or  $b^{-1}$ , i.e.,  $n = n_+ + n_-$ , where  $n_+$  is the sum of the positive powers of  $b$  in this expression of  $h'$  and  $n_-$  is the magnitude of the sum of negative powers of  $b$ .

If none of the  $h_i$  are Dehn twists about  $\beta$  then  $(\alpha^j) = (h(\alpha^j))$ . In this case,  $\sigma = ((\alpha^j), (b(\alpha^j)), (b^{-1}b(\alpha^j) = (\alpha^j)))$  is a good oriented sequence.

If  $((\alpha^j), (\beta^j))$  is a positively oriented good pair then  $((\alpha^j), (-\beta^j), (-\alpha^j), (\beta^j))$  is a negatively oriented good sequence. Performing  $n_-$  such substitutions we get a positively oriented good sequence  $(\alpha^j) \xrightarrow{\sigma} (h(\alpha^j))$ .  $\square$

**Definition 3.5.** Let  $\sigma = (h(\alpha_n^j) = \alpha_0^j, \alpha_1^j, \dots, \alpha_{n-1}^j, \alpha_n^j)$  be a good oriented sequence. Let  $F_i = F \times \{\frac{i}{n}\}$  for  $0 \leq i < n$  and let  $D_i^j = \alpha_i^j \times [\frac{i}{n}, \frac{i+1}{n}]$ , for  $0 \leq i < n$ , in  $M_h$ . Let  $X = (\cup_i F_i) \cup (\cup_{i,j} D_i^j)$  and orient  $F_i$  and  $D_i^j$  as in Definition 3.1. Define  $B_\sigma = \langle \cup_i F_i; \cup_{i,j} D_i^j \rangle$  as the associated branched surface. Figure 7 shows the neighborhood of  $F$  in  $X$  while Figure 9 shows a neighborhood of  $F$  in the associated branched surface.

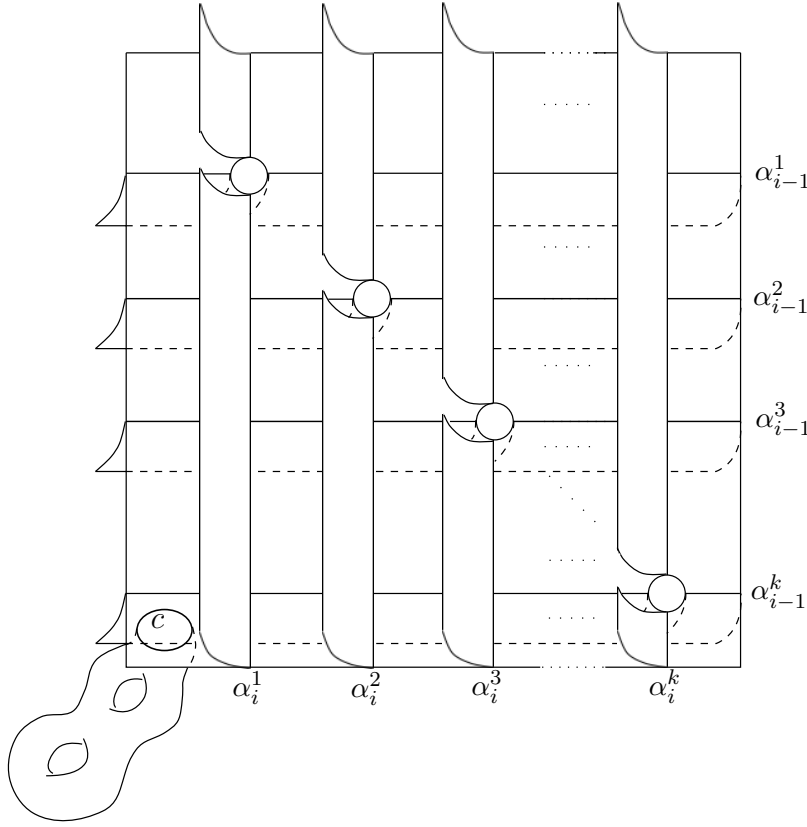
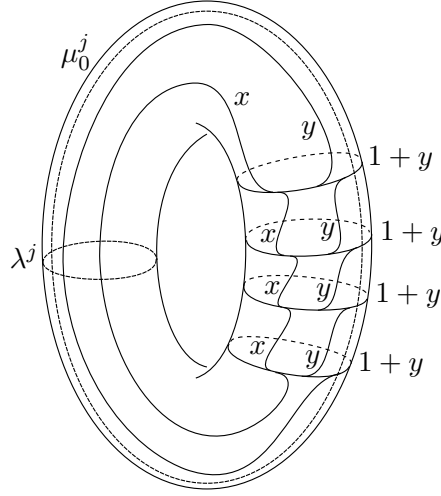

FIGURE 9. A neighborhood of one of the fibres in the branched surface  $B$ . The small circles along the diagonal represent longitudes of the boundary tori. The vertical subarcs of the boundaries of the vertical disk sectors lie on these boundary tori. Compare with Figure 7.

**Lemma 3.6.** *Let  $\sigma = (h(\alpha_n^j) = \alpha_0^j, \alpha_1^j, \dots, \alpha_{n-1}^j, \alpha_n^j)$  be a good oriented sequence in  $F$  and  $B_\sigma$  the associated branched surface in  $M_h$ . Then  $B_\sigma$  has no sink disk or half sink disk.*

*Proof.* As the sequence  $\sigma$  is good and oriented for each fixed  $i$ , the tuple of arcs  $(\alpha_i^j)$  is parallel and  $|\alpha_i^j \cap \alpha_{i-1}^k| = \delta_j^k$ , so a neighborhood of  $F_i$  in  $B_\sigma$  is as shown in Figure 9.

The sectors of  $B_\sigma$  consist of disks  $D_i^j = \alpha_i^j \times [\frac{i}{n}, \frac{i+1}{n}]$  and components of  $F_i \setminus \{\alpha_i^j \cup \alpha_{i-1}^j\}_{j=1 \dots k}$ . As  $F_{i-1}$  and  $F_i$  both have a co-orientation in the direction of increasing  $t$  for  $(x, t) \in M_h$ , so for any orientation of  $D_i^j$ ,  $\partial D_i^j$  is the union of two arcs in  $\partial M_h$ , together with one arc with the direction of the cusp pointing into the disk and one arc with the direction of the cusp pointing outwards. Similarly, as  $\alpha_i^j$  and  $\alpha_i^{j+1}$  are oriented in parallel, each

 FIGURE 10. The weighted boundary train track when  $n = 4$ 

disk component of  $F_i \setminus \{\alpha_i^j, \alpha_{i-1}^j\}_{j=1\dots k}$  has a boundary arc with cusp direction pointing outwards. Therefore no branch sector in  $B_\sigma$  is a sink disk or a half sink disk.  $\square$

*Remark 3.7.* Notice that  $B_\sigma = \langle \cup_i F_i; \cup_{i,j} D_i^j \rangle$  is a splitting (see [31]) of the original branched surface  $B_\alpha = \langle F; \cup_j D^j \rangle$  and, equivalently,  $B_\sigma$  collapses to  $B_\alpha$ . So in particular, laminations carried by  $B_\sigma$  are also carried by  $B_\alpha$ .

Now consider the train tracks  $\tau^j = B_\sigma \cap T^j$ . Focus on one of the  $\tau^j$ . For some choice of meridian  $\mu_0^j$ . Recall that we fixed a coordinate system  $(\lambda^j, \mu^j)$  on  $T^j$ . For simplicity of exposition, we now make a second choice  $\mu_0^j$  of meridian. This choice is dictated by the form of  $\tau^j$ ; namely, we choose  $\mu_0^j$  to be disjoint from the disks  $D_i^j$  so that  $\tau^j$  has the form shown in Figure 10. Notice that there is a change of coordinates homeomorphism taking slopes in terms to the coordinate system  $(\lambda^j, \mu_0^j)$  to slopes in terms of the coordinate system  $(\lambda^j, \mu^j)$ . Since  $\lambda^j$  is unchanged, this homeomorphism takes an open interval about 0 to an open interval about 0. Assign to  $\tau^j$  the measure determined by weights  $x, y$  shown in Figure 10. In terms of the coordinate system  $(\lambda^j, \mu_0^j)$ ,  $\tau^j$  carries all slopes realizable by

$$\frac{x - y}{n(1 + y)}$$

for some  $x, y > 0$ . Therefore, in terms of the coordinate system  $(\lambda^j, \mu_0^j)$ ,  $\tau^j$  carries all slopes in  $(-\frac{1}{n}, \infty)$ . Converting to the coordinate system  $(\lambda^j, \mu^j)$ ,  $\tau^j$  carries all slopes in some open neighborhood of 0. Repeat for all  $j$ .

By Theorem 2.10, we see that the branched surface  $B_\sigma$  carries laminations  $\lambda_{(\bar{x}, \bar{y})}$  realizing multislopes  $(\frac{x_1-y_1}{n(1+y_1)}, \frac{x_2-y_2}{n(1+y_2)}, \dots, \frac{x_k-y_k}{n(1+y_k)})$  for any strictly positive values of  $x_1, \dots, x_k, y_1, \dots, y_k$  and hence realizing all rational multislopes in some open neighborhood of  $\bar{0} \in \mathbb{R}^k$ .

**Lemma 3.8.** *Suppose the weights  $\bar{x}, \bar{y}$  are distinct and have strictly positive coordinates. Then each lamination  $\lambda_{(\bar{x}, \bar{y})}$ , contains only noncompact leaves. Furthermore, each lamination  $\lambda_{(\bar{x}, \bar{y})}$  extends to a taut foliation  $\mathcal{F}_{(\bar{x}, \bar{y})}$ , which realizes the same multislope.*

*Proof.* Suppose that  $\lambda_{(\bar{x}, \bar{y})}$  contains a compact leaf  $L$ . Such a leaf determines a transversely invariant measure on  $B$  given by counting intersections with  $L$ .

Now focus on any  $i, j$ , where  $0 \leq i, j < n$ . By considering, for example, a simple closed curve in  $F_i$  parallel to the arc  $\alpha_i^j$ , we see that there is an oriented simple closed curve in  $F_i$  which intersects the branching locus of  $B_\sigma$  exactly  $k$  times that has orientation consistent with the branched locus. Since this is true for all possible  $i, j$ , it follows that the only transversely invariant measure  $B$  can support is the one with all weights on the branches  $D_i^j$  necessarily 0. But this means that  $\lambda_{(\bar{x}, \bar{y})}$  realizes multislope  $\bar{0}$  and hence that  $\bar{x} = \bar{y}$ .

The complementary regions to the lamination  $\lambda_{(\bar{x}, \bar{y})}$  are product regions. Filling these up with product fibrations, we get the required foliation  $\mathcal{F}_{(\bar{x}, \bar{y})}$ , which also has no compact leaves and is therefore taut.  $\square$

#### 4. EXAMPLE

As discussed in the introduction, an open book with connected binding and monodromy with fractional Dehn twist coefficient more than one supports a contact structure which is the deformation of a co-orientable taut foliation [16]. However for open books with disconnected binding there is no such universal lower bound on the fractional Dehn twist coefficient. This was illustrated by Baldwin-Etnyre [2] who constructed a sequence of open books with arbitrarily large fractional Dehn twist coefficients and disconnected binding that support contact structures which are not deformations of a taut foliation. This shows, in particular, that there is no global neighborhood about the multislope of the fiber of a surface bundle such that Dehn filling along rational slopes in that neighborhood produces closed manifolds with taut foliations.

The notion of ‘sufficiently close’ in Corollary 1.2 can however be bounded below for a given manifold. Deleting a neighbourhood of the binding in the Baldwin-Etnyre examples gives a surface bundle and using the techniques developed in the previous sections we now calculate a neighborhood of multislopes realized by taut foliations, around the multislope of the fiber in this

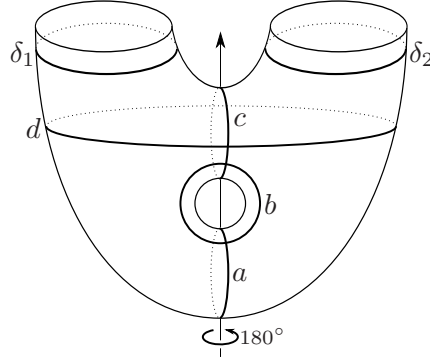

FIGURE 11. The Baldwin-Etnyre examples

fibration. In particular, we observe that this neighbourhood does not contain the meridional multislope. So Dehn filling along these slopes does not give a taut foliation of the sequence of Baldwin-Etnyre manifolds, as is to be expected.

The following is a description of the Baldwin-Etnyre examples[2]. Let  $T$  denote the genus one surface with two boundary components,  $B_1$  and  $B_2$ . Let  $\psi$  be the diffeomorphisms of  $T$  given by the product of Dehn twists,

$$\psi = D_a D_b^{-1} D_c D_d^{-1}$$

where  $a, b, c$  and  $d$  are the curves shown in Figure 11 (reproduced from Figure 1 of Baldwin-Etnyre[2]). Then  $\psi$  is pseudo-Anosov by a well-known construction of Penner [34]. We define

$$\psi_{n,k_1,k_2} = D_{\delta_1}^{k_1} D_{\delta_2}^{k_2} \psi^n$$

where  $\delta_1$  and  $\delta_2$  are curves parallel to the boundary components  $B_1$  and  $B_2$  of  $T$ .

Let  $M_{n,k_1,k_2}$  be the open book  $(T, \psi_{n,k_1,k_2})$ . Let  $N(B_1), N(B_2)$  be regular neighbourhoods of  $B_1$  and  $B_2$  in  $M_{n,k_1,k_2}$  and let  $M'_{n,k_1,k_2} = M_{n,k_1,k_2} \setminus (N(B_1) \cup N(B_2))$ . Let  $\lambda_1, \lambda_2$  be the closed curves in  $T \cap \partial M'_{n,k_1,k_2}$  represented by  $B_1, B_2$ , with induced orientation. The monodromy  $\psi_{n,k_1,k_2}$  is freely isotopic to the pseudo-Anosov map  $\psi^n$ . Let  $\mu_1, \mu_2$  be the suspension flow of a point in  $\lambda_1$  and  $\lambda_2$  respectively under the monodromy  $\psi^n$ . As  $\psi^n$  is the identity on  $\partial T$ ,  $\mu_i = p_i \times S^1$  in  $\partial M'_{n,k_1,k_2} = (B_1 \times S^1) \cup (B_2 \times S^1)$  for  $p_i \in \lambda_i$ .

We use these pair of dual curves  $(\lambda_1, \mu_1)$  and  $(\lambda_2, \mu_2)$  as coordinates to calculate the slope of curves on the torii boundary of  $M'_{n,k_1,k_2}$  as detailed in Subsection 2.2.

If  $D_1$  is the meridional disk of a regular neighbourhood  $N(B_1)$  of  $B_1$  in  $M_{n,k_1,k_2}$  then  $\partial D_1 = \mu_1$ . Similarly, for  $D_2$  a meridional disk of a regular neighbourhood of  $B_2$  in  $M_{n,k_1,k_2}$ ,  $\partial D_2 = \mu_2$ .

In order to express the monodromy of the surface bundle in terms of the Gervais generators we use the pseudo-Anosov monodromy  $\psi^n = \psi_{n,0,0}$  which is freely isotopic to  $\psi_{n,k_1,k_2}$ , with the observation that Dehn filling  $M'_{n,0,0}$  along slopes  $-\frac{1}{k_1}$  and  $-\frac{1}{k_2}$  gives the manifold  $M_{n,k_1,k_1}$ . So for  $M'_{n,0,0}$  we have  $\text{slope}(\partial D_1) = -\frac{1}{k_1}$ ,  $\text{slope}(\partial D_2) = -\frac{1}{k_2}$ .

As shown in Theorem 1.16 of Baldwin-Etnyre[2], for any  $N > 0$  there exist  $n, k_1 > N$  such that the corresponding open book in  $M_{n,k_1,n}$  has a compatible contact structure that is not a deformation of the tangent bundle of a taut foliation. We shall now show that the slope  $-\frac{1}{n}$  lies outside the interval of perturbation that gives slopes of taut foliations via our construction. And hence, the manifolds  $M_{n,k_1,n}$  cannot be obtained by capping off the taut foliations realized by our interval of boundary slopes around the fibration.

To obtain the branched surface required in our construction in the previous sections we need a good sequence of arcs  $\alpha^j \rightarrow \phi^{-1}(\alpha^j)$  where  $\phi = \psi^n$ ,  $j = 1, 2$ . These arcs are used to construct product disks which we then smoothen along copies of the fiber surface to get the required branched surface.

Following the method outlined in Lemma 3.4 we need to express  $\phi^{-1}$  in terms of the Gervais generators. The curves  $a, b$  and  $c$  correspond to the generating curves  $\eta_1, \beta$  and  $\eta_2$  among the Gervais generators as can be seen in Figure 8. We now need to express the curve  $d$  in terms of these generating curves.

**Definition 4.1.** Let  $S_{g,n}$  be a surface of genus  $g$  and  $n$  boundary components. Consider a subsurface of  $S_{g,n}$  homeomorphic to  $S_{1,3}$ . Then for curves  $\alpha_i, \beta, \gamma_i$  as shown in the Figure 12 (reproduced from Figure 2 of Gervais[14]), the star-relation is

$$(D_{\alpha_1} D_{\alpha_2} D_{\alpha_3} D_{\beta})^3 = D_{\gamma_1} D_{\gamma_2} D_{\gamma_3}$$

where  $D$  represents Dehn-twist along the corresponding curves.

Let  $S$  be the component of  $T \setminus d$  which is homeomorphic to a once-punctured torus. Let  $\gamma_1 = d$  and  $\gamma_2, \gamma_3$  be curves bounding disjoint disks  $D_1$  and  $D_2$  in  $S$  so that  $S \setminus (D_1 \cup D_2)$  is homeomorphic to  $S_{1,3}$ . As  $\gamma_2, \gamma_3$  are trivial in  $T$ ,  $\gamma_1 = d$  and  $\alpha_1 = \alpha_2 = \alpha_3 = a$ , so the star relation reduces to  $D_d = (D_a^3 D_b)^3$ .

Hence, the monodromy  $\psi$  in terms of the Gervais generators is the word

$$\psi = D_a D_b^{-1} D_c (D_a^3 D_b)^{-3}$$



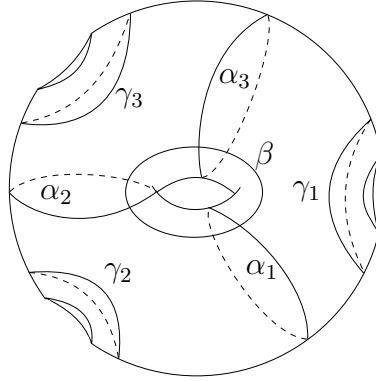

FIGURE 12. The Gervais star-relation

which gives us

$$\psi^{-1} = D_a^3 D_b D_a^3 D_b D_a^3 D_b D_c^{-1} D_b D_a^{-1}$$

Take arcs  $\alpha_1, \alpha_2$  as shown in Figure 8, where  $a = \eta_1, b = \beta$  and  $c = \eta_2$ . Then as  $(\alpha_j, D_b(\alpha_j))$  is a negatively oriented pair and  $\alpha_j = D_a(\alpha_j), \alpha_j = D_c(\alpha_j)$  so we have a negatively oriented good sequence  $(\alpha_1, \alpha_2) \rightarrow (\psi^{-1}(\alpha_1), \psi^{-1}(\alpha_2))$  obtained by taking the sequence of arcs

$$\sigma = (\alpha_j, D_a^3 D_b(\alpha_j), D_a^3 D_b D_a^3 D_b(\alpha_j), D_a^3 D_b D_a^3 D_b D_a^3 D_b(\alpha_j), D_a^3 D_b D_a^3 D_b D_c^{-1} D_b D_a^{-1}(\alpha_j) = \psi^{-1}(\alpha_j)) \text{ for } j = 1, 2.$$

Let  $B_\sigma$  be the branched surface corresponding to this good oriented sequence as in Definition 3.5. The weighted train track  $\tau_\sigma = B_\sigma \cap \partial M'_{n,0,0}$  on the boundary torii is as shown in Figure 10.

The slope of this measured boundary lamination is  $\frac{x-y}{4(1+y)}$  so the interval of slopes that are realized by taut foliations is  $(-\frac{1}{4}, \infty)$ .

When the monodromy is  $\psi^n$  (instead of  $\psi$ ), by a similar argument, we get the slope of the measured lamination on the boundary as  $\frac{x-y}{4n(1+y)}$  so that the interval of slopes realized by taut foliations is  $(-\frac{1}{4n}, \infty)$ . And we observe that the point  $(-\frac{1}{k_1}, -\frac{1}{n}) \notin (-\frac{1}{4n}, \infty) \times (-\frac{1}{4n}, \infty)$ , i.e, the taut foliations from our construction cannot be capped off to give a taut foliation of the Baldwin-Etnyre examples.

## REFERENCES

1. J. W. Alexander, *Note on Riemann spaces*, Bull. Amer. Math. Soc., **26** (1920), 370–372.
2. J. Baldwin and J. Etnyre, *Admissible transverse surgery does not preserve tightness*, arXiv:1203.2993
3. M. Brittenham, *Essential laminations in Seifert-fibered spaces*, Topology **32(1)** (1993), 61–85.

4. D. Calegari and N. Dunfield, *Laminations and groups of homeomorphisms of the circle*, Invent. Math. **152** (2003), 149–207.
5. B. Casler, *An imbedding theorem for connected 3-manifolds with boundary*, Proc. A.M.S. **16** (1965), 559–566.
6. V. Colin and K. Honda, *Stabilizing the monodromy of an open book decomposition*, Geom. Dedicata **132** (2008), 95–103.
7. C. Delman and R. Roberts, *Alternating knots satisfy Strong Property P*. Comment. Math. Helv. **74** (1999), no. 3, 376–397.
8. Y. Eliashberg and W. P. Thurston, *Confoliations*, University Lecture Series **13**, American Mathematical Society (1998).
9. D. Eisenbud, U. Hirsch and W. D. Neuman, *Transverse foliations of Seifert bundles and self-homeomorphisms of the circle*, Comment. Math. Helv. **56(4)** (1981), 638–660.
10. D. Gabai, *Foliations and the topology of 3-manifolds*, J. Differential Geom. **18** (1983), no. 3, 445–503.
11. D. Gabai, *Foliations and the topology of 3-manifolds. II*, J. Differential Geom. **26** (1987), no. 3, 461–478.
12. D. Gabai, *Foliations and the topology of 3-manifolds. III*, J. Differential Geom. **26** (1987), no. 3, 479–536.
13. D. Gabai and U. Oertel, *Essential Laminations in 3-Manifolds*, Ann. Math. **130**, (1989), 41–73.
14. S. Gervais, *A finite presentation of the mapping class group of a punctured surface*, Topology **40** (2001), no. 4, 703–725.
15. A. Haefliger, *Varietes feuilletés*, Ann. Scuola Norm. Sup. Pisa (3) **16** (1962) 367–397
16. K. Honda, W.H. Kazez and G. Matic, *Right-veering diffeomorphisms of compact surfaces with boundary II*, Geometry & Topology, **12**, (2008), 2057–2094.
17. M. Jankins and W. D. Neumann, *Rotation numbers of products of circle homeomorphisms*, Math. Ann. **271(3)** (1985), 381–400.
18. J. Jun, *(−2, 3, 7)-pretzel knot and Reebless foliation*, arXiv:math/0303328v1.
19. P. B. Kronheimer and T. Mrowka, *Monopoles and three-manifolds*, Cambridge University Press, 2007.
20. P. Kronheimer, T. Mrowka, P. Ozsváth, and Z. Szabó, *Monopoles and lens space surgeries*, Annals of Math. **165** (2007), 457–546.
21. W. H. Kazez and R. Roberts, *Fractional Dehn twists in knot theory and contact topology*, ArXiv:1201.5290.
22. W. H. Kazez and R. Roberts, *Continuous confoliations*, preprint.
23. T. Li, *Laminar branched surfaces in 3-manifolds*, Geom. Top. **6** (2002), 153–194.
24. T. Li, *Boundary train tracks of laminar branched surfaces.*, Topology and geometry of manifolds (Athens, GA, 2001), 269–285, Proc. Sympos. Pure Math., **71**, Amer. Math. Soc., Providence, RI, 2003.
25. T. Li and R. Roberts, *Taut foliations in knot complements*, to appear in Pac. J. Math., ArXiv:1211.3066.
26. W.B. Lickorish, *A foliation for 3-Manifolds*, Ann. of Math. (2) **82** 414–420 1965.
27. R. Myers, *Open book decompositions of 3-manifolds*, Proc. A.M.S. **72(2)** (1978), 397–402.
28. R. Naimi, *Foliations transverse to fibers of Seifert manifolds*, Commet. Math. Helv. **69(1)** (1994), 155–162.
29. S.P. Novikov, *The topology of foliations*. (Russian), Trans. Moscow Math. Society **14** (1965), 248–278.

30. U. Oertel, *Incompressible branched surfaces*, Invent. Math. **76** (1984), 385–410.
31. U. Oertel, *Measured laminations in 3-manifolds*, Trans. A.M.S. **305** (1988), 531–573.
32. P. Ozsváth and Z. Szabó, *Holomorphic disks and genus bounds*, Geom. Topol. **8** (2004), 311–334.
33. C. F. B. Palmeira, *Open manifolds foliated by planes*, Ann. Math. (2) **107** (1978), no. 1, 109–131.
34. R. Penner, *A construction of pseudo-Anosov homeomorphisms.*, Trans. Amer. Math. Soc. **310** (1988), no. 1, 179–197.
35. R. Roberts, *Constructing taut foliations*, Comment. Math. Helv. **70** (1995), 516–545.
36. R. Roberts, *Taut foliations in punctured surface bundles. I*, Proc. London Math. Soc. (3) **82** (2001), no. 3, 747–768.
37. R. Roberts, *Taut foliations in punctured surface bundles, II*, Proc. London Math. Soc. (3) **83** (2001), no. 2, 443–471.
38. R. Roberts, J. Shareshian and M. Stein, *Infinitely many hyperbolic 3-manifolds which contain no Reebless foliation*, J.A.M.S. **16(3)**, 639–379.
39. D. Rolfsen, *Knot and Links*, Mathematics Lecture Series, No. 7. Publish or Perish, Inc., Berkeley, Calif., 1976.
40. H. Rosenberg, *Foliations by planes*, Topology **6** (1967) 131–138
41. W. P. Thurston *On the geometry and dynamics of diffeomorphisms of surfaces*, Bull. Amer. Math. Soc. **19**, (1988), pp 417–431.
42. W. P. Thurston, *A norm for the homology of 3-manifolds*, Mem. Amer. Math. Soc. 59 (1986), no. 339, i–vi and 99–130.
43. W. P. Thurston, *Three-manifolds, foliations and circles, II*, Unfinished manuscript, 1998.
44. R. Williams, *Expanding attractors*, Inst. Hautes Études Sci. Publ. Math. **43** (1974), 169–203.
45. J. Wood, *Foliations on 3-manifolds*, Ann. of Math. **89(2)** (1969), 336–358.

DEPARTMENT OF MATHEMATICS, WASHINGTON UNIVERSITY IN ST. LOUIS, ST. LOUIS, MO 63130

*E-mail address:* tejas@math.wustl.edu

DEPARTMENT OF MATHEMATICS, WASHINGTON UNIVERSITY IN ST. LOUIS, ST. LOUIS, MO 63130

*E-mail address:* roberts@math.wustl.edu