

Quantum Key Distribution based on Single Photon Bi-partite Correlation

Kim Fook Lee,^{1,*} Yong Meng Sua,¹ and Harith B. Ahmad²

*¹Department of Physics,
Michigan Technological University,
Houghton, Michigan 49931*

*²Department of Physics,
University of Malaya,
50603 Kuala Lumpur, Malaysia*

(Dated: July 20, 2012)

Abstract

We present a scheme for key distribution based on bi-partite correlation of single photons. Alice keeps an ancilla photon and sends a signal photon to Bob, where intrinsic bi-partite correlation of these photons is obtained through first order intensity correlation in their detectors. The key bits are distributed through sharing four bi-partite correlation functions and photon counting. The scheme consists of two parts; first, Alice prepares deterministic photon states and Bob measures the photon states based on his random choice on correlation functions. Second, Alice guesses Bob's choice of correlation functions and sets the key bits by sending out photon states. Bob verifies the key bits through the photon states regardless Alice made a right or wrong guess. We called this key distribution scheme as prepare-measure-guess-verify (PMGV) protocol. We discuss the protocol by using a highly attenuated laser light, and then point out the advantages of using a fiber based correlated photon-pair to achieve better performance in security, communication distance and success rate of key distribution.

Superposition and entanglement are essential in developing quantum information technologies for real world applications especially for secure communication with quantum key distribution (QKD) [1, 2]. QKD has been securely implemented in an optical free-space link (144 km) with polarization entangled photon-pair [3] and an optical fiber network (45 km) with six different protocols [4]. The BB84 and B92 protocols [5, 6] are secure against photon number splitting attack (PNS). This attack is only a threat if Alice and Bob shared a fake single-photon source such as using a highly attenuated laser light. To overcome photon number splitting attack (PNS) [7, 8] due to the use of highly attenuated laser light in a lossy long channel, decoy-state protocols [9–11] and SARG04 protocol [12] have been proposed and implemented. Measurement-device-independent QKD [13] is recently proposed to enhance secure communication against all detector side channel attacks and double communication distance by using highly attenuated laser light. The approach requires coincidence detection of a signal pulse from Alice and a reference pulse from Bob. In this work, we propose a QKD scheme based on single photon bi-partite correlation.

Correlation functions or expectation values of two observable are classical information as a consequence of the collapse of wave functions in a measurement process. Correlation functions of two Einstein-Podolsky-Rosen (EPR) entangled photons are obtained through nonlocal interferences of their probability amplitudes at two observers. The quantumness of these interferences is the exhibition of particle-wave duality. The quantum mechanics without probability amplitude was proposed [14], leading to the possibility of quantum information processing without probability amplitudes, that is, quantum information processing with correlation functions.

Bi-partite correlation of coherent light state has been observed by wave mechanical interferences of electromagnetic light fields with different modulated frequencies [15, 16]. By post-selecting a pair or multiple pairs of beat frequencies from detectors, the bi-partite or multiple-partite correlation functions were obtained for simulating the violation of Bell's inequalities [17] and the locality of Greenberger-Horne-Zeilinger (GHZ) entanglement [18, 19]. Recently, a coherent light field and a random phase-modulated noise field was used to generate the optical bi-partite correlation without applying any post-selecting techniques [20]. Instead, the correlation was obtained through mean-value measurement of the multiplied random beat signals of two observers. The experiment showed that the phases information between two observers was not diminished in the presence of random noises. We further

interrogated the generation of bi-partite correlation by using two weak coherent states in balanced homodyne detection [21], where quantum noises, shot noises and electronic noises were included in the measurement process. These noises were used to protect the phases information between two observers. Bits correlations were then extracted from the correlation functions.

In this paper, we present a new protocol for key distribution by using single photon bi-partite correlation. The security of the protocol is protected by the principle of quantum mechanics such as quantum non-cloning theorem, superposition and entanglement. We use four bi-partite correlations to distribute key between Alice and Bob. Our protocol is relied on interference of single photons, i.e., the first order intensity correlation of an ancilla photon in Alice and a signal photon in Bob. These single photons have to be intrinsically correlated through a highly attenuated laser light or a photon-pair source. We will first discuss the protocol by using single photons (ancilla and signal) prepared from a highly attenuated laser light. Our protocol requires coincidence detection of ancilla photon and signal photon. We then discuss the use of a fiber based correlated photon-pair or two time-synchronized deterministic single-photon sources for improving the success rate of key distribution and increasing the communication distance by factor two in comparison to the use of a highly attenuated laser light. The correlated photon-pair is easy-to-use and more tolerant to decoherence compared to an entangled photon-pair. The essence of the paper is to propose a new scheme for key distribution based on single photon bi-partite correlation. Secure communication between Alice and Bob is established through four types of bi-partite correlation functions (C1, C2, C3, C4), which can be divided into two groups (Ψ, Φ). Alice first prepares a sequence of deterministic states, Bob measures each photon state randomly based on his random choice on C1, C2, C3, or C4 and then tells Alice through classical channel about the sequence of groups (Ψ, Φ) that he has randomly chosen. Alice guesses the correlation based on the group information and sets the key bit by sending another signal photon to Bob. Bob verifies the key bit by the outcome of his measurement regardless Alice made a right or wrong guess. We called this scheme as prepare-measure-guess-verify (PMGV) protocol.

The proposed experiment setup is shown in Fig.1. A pulsed, 45°-polarized laser light is used to provide a coherent state with large mean photon number per pulse. The coherent state is split by a polarizing beam splitter (PBS) into a coherent state $|\alpha\rangle_H = ||\alpha|e^{i\phi\alpha}\rangle$

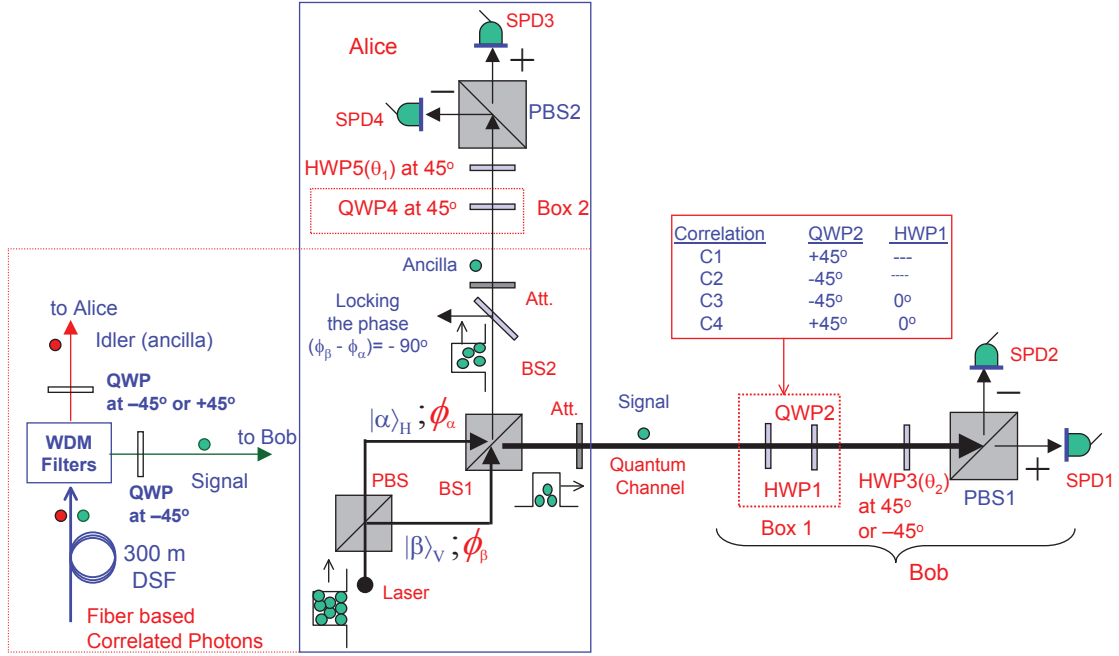

FIG. 1: The experiment scheme for implementing key distribution using a signal photon and an ancilla photon. Also shown is the use of a fiber based correlated photon-pair as photon source to replace the highly attenuated laser light. The dotted box is the wave plates used for preparing bi-partite correlation between Alice and Bob.

with horizontal polarization and a coherent state $|\beta\rangle_V = ||\beta|e^{i\phi_\beta}\rangle$ with vertical polarization. These coherent states are combined through a beam splitter (BS1), producing two spatially separated beams, i.e, beam 1 and beam 2 at each output of the BS1. Beam 1 is sent to Bob and the other beam 2 is kept by Alice. To create single photon quantum channel between Alice and Bob, the beam 1 is attenuated to single photon level, i.e., the mean photon number per pulse less than 1. The single photon sent to Bob in the quantum channel is called signal photon. The signal photon is inherited from the superposition of $|\alpha\rangle_H + |\beta\rangle_V$ or two paths before the BS1, where the relative phase $(\phi_\beta - \phi_\alpha) = -90^\circ$ is locked through beam 2 at Alice. Similarly, the beam 2 is further attenuated to single photon level. The single photon kept in Alice is called ancilla photon. The ancilla photon in Alice and the signal photon in Bob are intrinsically correlated in the laser and phase-locked through the phase-locking circuit at $(\phi_\beta - \phi_\alpha) = -90^\circ$. Then, the bi-partite correlation between these photons is obtained by using wave plates in Alice and Bob as shown in the dotted boxes in Fig.1. In our previous

	Shared Correlation Function	Maximum Correlation	Alice ($\phi_\beta - \phi_\alpha = -90^\circ$) $\text{Cos} (2\theta_1 + \phi_\beta - \phi_\alpha)$	Bob ($\phi_\beta - \phi_\alpha = -90^\circ$) $\pm \text{Cos} (2\theta_2 \pm (\phi_\beta - \phi_\alpha))$
Ψ	C1= $-\text{Cos} 2(\theta_1 - \theta_2)$	$\theta_1 = \theta_2 = +45^\circ$	+	-
	C2= $+\text{Cos} 2(\theta_1 + \theta_2)$	$\theta_1 \neq \theta_2$ $\theta_1 = +45^\circ; \theta_2 = -45^\circ$	+	+
Φ	C3= $-\text{Cos} 2(\theta_1 + \theta_2)$	$\theta_1 \neq \theta_2$ $\theta_1 = +45^\circ; \theta_2 = -45^\circ$	+	-
	C4= $+\text{Cos} 2(\theta_1 - \theta_2)$	$\theta_1 = \theta_2 = +45^\circ$	+	+

FIG. 2: The definition of the group (ψ, ϕ) , settings of θ_1 and θ_2 for maximum correlation, the interference signals at Alice and Bob for which detector will fire for all four types of bi-partite correlations C1, C2, C3 and C4.

work [21], we have verified four types of bi-partite correlation functions $C1 = -\cos 2(\theta_1 - \theta_2)$, $C2 = +\cos 2(\theta_1 + \theta_2)$, $C3 = -\cos 2(\theta_1 + \theta_2)$, and $C4 = +\cos 2(\theta_1 - \theta_2)$ through the combination of wave plates as shown in the inset of Fig.1. The half-wave plates (HWP3 and HWP5) before the polarizing beam splitters (PBS1 and PBS2) in Alice and Bob are used for projecting polarization angles θ_1 and θ_2 so that maximum correlation, i.e., $C_{1,2,3,4} = \pm 1$ is obtained. In the following discussion, let's assume that an ancilla photon and a signal photon are available at the same time slots. We denote '+' and '-' for these photons passed through and reflected from their PBSs. If the single photon detector (SPD) '+' or '-' detects a photon, then we encode the valid detection as bit '1' or bit '0', respectively. For each correlation function, Alice and Bob can control their photons to be in the '+' or '-' port of their PBSs by using their HWPs. We need to choose the best settings for their HWPs so that we could obtain maximum correlations of their photons and also distribute the key effectively.

We illustrate each bi-partite correlation function and the optimum settings of θ_1 and θ_2 in Fig.2. For the correlation function $C1 = -\cos 2(\theta_1 - \theta_2)$, Alice and Bob receive their photons with interference terms as given by $+\text{Cos}(2\theta_1 + (\phi_\beta - \phi_\alpha))$ and $-\text{Cos}(2\theta_2 + (\phi_\beta - \phi_\alpha))$, respectively. By projecting the HWP5 in Alice at $\theta_1 = +45^\circ$ and also the HWP3 in Bob at $\theta_2 = +45^\circ$, we have $C1 = -1$ indicating maximum anti-correlation between Alice and Bob. This can be easily noticed with the help of phase-locking $(\phi_\beta - \phi_\alpha) = -90^\circ$, the interference term in Alice, $+\text{Cos}(2(+45^\circ) + (\phi_\beta - \phi_\alpha)) \rightarrow '+'$ and interference term in Bob, $-\text{Cos}(2(+45^\circ) + (\phi_\beta - \phi_\alpha)) \rightarrow '-'$. This implies that the ancilla photon in Alice

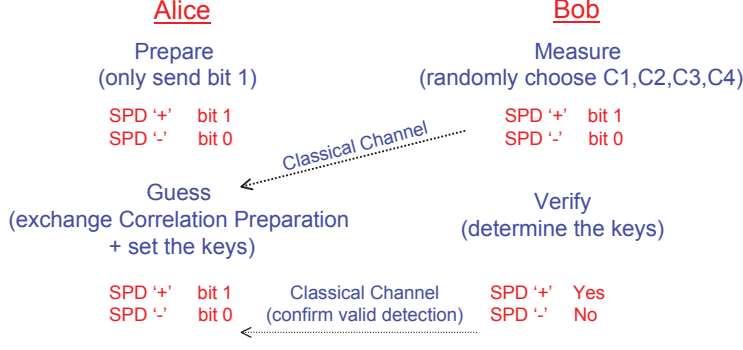

FIG. 3: Conceptual prepare-measure-guess-verify protocol for key distribution based on single photon bi-partite correlation.

passed through the PBS2 and detected by the '+' SPD3, and also the signal photon in Bob is reflected from the PBS1 and detected by the '-' SPD2. For the correlation function, $C2 = +\cos 2(\theta_1 + \theta_2)$, the maximum correlation $C2=+1$ is obtained by projecting $\theta_1 = +45^\circ$ and $\theta_2 = -45^\circ$. Alice has the same interference term, but Bob has the interference term $+\cos(2\theta_2 - (\phi_\beta - \phi_\alpha)) \rightarrow +\cos(2(-45^\circ) - (-90^\circ)) \rightarrow '+'$. As a result, both the '+' SPD3 in Alice and the '+' SPD1 in Bob will detect a photon. For the correlation function, $C3 = -\cos 2(\theta_1 + \theta_2)$, we still project $\theta_1 = +45^\circ$ and $\theta_2 = -45^\circ$ for the maximum correlation $C3=-1$. Alice's '+' SPD3 still see her ancilla photon. While Bob has the interference term $-\cos(2\theta_2 - (\phi_\beta - \phi_\alpha)) \rightarrow -\cos(2(-45^\circ) - (-90^\circ)) \rightarrow '-'$, and so the '-' SPD2 will see his signal photon. For the correlation function, $C4 = +\cos 2(\theta_1 - \theta_2)$, the $\theta_1 = +45^\circ$ and the $\theta_2 = +45^\circ$ are used for the maximum correlation $C4=1$. Similarly, Alice will see her ancilla photon in the '+' SPD3. Bob has the interference term $+\cos(2\theta_2 + (\phi_\beta - \phi_\alpha)) \rightarrow +\cos(2(45^\circ) + (-90^\circ)) \rightarrow '+'$. The '+' SPD1 in Bob will detect a photon. For all four bi-partite correlations, Alice will have her ancilla photon in the '+' SPD3. Alice uses this valid detection for preparing the signal photon that sent to Bob. We will divide the four bi-partite correlations into two groups, $C1,C2 \rightarrow \Psi$ and $C3,C4 \rightarrow \Phi$.

Now, let's discuss the protocol of key distribution between Alice and Bob using the shared correlation function as shown in Fig.3. The scheme can be divided into two parts; the first part is Prepare-Measure (PM) part and the second part is Guess-Verify (GV). In the PM part, Alice prepares an ancilla photon for herself and also a signal photon to be sent to Bob. First, Alice has to verify her ancilla photon is always bit '1' or detected by the '+' SPD3 as discussed before in Fig.2, so that the signal photon sent to Bob is phase-locked,

i.e, the relative phase between the horizontal and vertical components of the signal photon is kept constant. From here, we assume that Alice only prepares bit '1' and sends the bit information to Bob through the signal photon. Bob can randomly choose one of the four C1, C2, C3, and C4 correlation functions by means of randomly projecting the HWP1 and QWP2 as shown in the inset of Fig.1. If Bob chooses C1, his '-' SPD2 will 'click' as shown in Fig.2 and then he encoded the detection as bit '0'. Similarly, if Bob chooses C2 or C3 or C4, he will have bit '1' or '0' or '1', respectively. Bob can randomly generate the key by his choice of correlation functions. However, the key is not shared with Alice. Fig.2. shows the expected bit correlation for each correlation between Alice and Bob in the PM part.

In the guess-verify (GV) part, Bob has to tell Alice about which group (Ψ, Φ) of his choice by using a classical channel. Since each group of (Ψ, Φ) has two choices of correlation functions, Alice has to guess one of two correlations within the group. No matter Alice's guess of Bob's choice of correlation is right or wrong, Alice will use her guess of correlation to generate the key bit. For example, Bob tells Alice that he used the group Ψ , Alice can choose C1 or C2. If Alice choose C1 (C2), she will generate bit '1'('0') as her key bit. In order for Alice to do that, she has to use the HWP1 and the QWP2 as shown in the dotted box in Bob's setup in Fig.1. In the GV part, Alice is mimicking the Bob's apparatus and generating the key bit based on her guess. She send the signal photon to Bob. Bob will use the QWP4 at $+45^\circ$ to replace the HWP1 and the QWP2 in his setup. However, Bob must keep the setting of the HWP3 ($+45^\circ, -45^\circ$) for his choice of correlation function that he has chosen in PM part. The sequence of the HWP3 angles will be used to verify the key bit sent by Alice. The essence of this verify part is Bob only (not Alice and Eve) knows his HWP3 angles. Bob can find out the key generated by Alice's guess by detecting the signal photon in the '+' SPD1 ('Yes'/right guess) or the '-' SPD2 ('No'/wrong guess). To implement the GV part, Alice and Bob must keep their HWP angles ($\theta_1 = +45^\circ, +45^\circ, +45^\circ, +45^\circ; \theta_2 = +45^\circ, -45^\circ, -45^\circ, +45^\circ$) for the correlation function C1, C2, C3 and C4, respectively. Since Alice and Bob have swapped their correlation preparation (HWP1+QWP2 \Leftrightarrow QWP4) and kept their projection angles (HWP3 and HWP5), Alice has to shift the phase-locked mode to $\phi_\beta - \phi_\alpha = 90^\circ$ for her guess on the correlation functions C2 and C3. The reason is for the correlation functions C2 and C3, Alice will have the interference terms in the cosine function changed from $+(\phi_\beta - \phi_\alpha) \rightarrow -(\phi_\beta - \phi_\alpha)$.

We illustrate the guess-verify part in more detail in Fig.4 about how Bob knows Alice's

Bob Measure	Alice Guess	Interference term in Alice	Interference term in Bob (verify)
C1 or bit '0' $\theta_1=+45^\circ$ $\theta_2=+45^\circ$	Correct (C1)	no shift $(\phi_\beta \phi_\alpha)=-90^\circ; \theta_1 =+45^\circ$ $-\cos(2\theta_1 + (\phi_\beta - \phi_\alpha)) \rightarrow -1$ or '-'	no shift $(\phi_\beta \phi_\alpha)=-90^\circ; \theta_2 =+45^\circ$ $+\cos(2\theta_2 + (\phi_\beta - \phi_\alpha)) \rightarrow +1$ or '+' or 'Yes'
	Wrong (C2)	shift $(\phi_\beta \phi_\alpha)=+90^\circ; \theta_1 =+45^\circ$ $+\cos(2\theta_1 - (\phi_\beta - \phi_\alpha)) \rightarrow +1$ or '+'	shift $(\phi_\beta \phi_\alpha)=+90^\circ; \theta_2 =+45^\circ$ $+\cos(2\theta_2 + (\phi_\beta - \phi_\alpha)) \rightarrow -1$ or '-' or 'No'
C2 or bit '1' $\theta_1=+45^\circ$ $\theta_2=-45^\circ$	Correct (C2)	shift $(\phi_\beta \phi_\alpha)=+90^\circ; \theta_1 =+45^\circ$ $+\cos(2\theta_1 - (\phi_\beta - \phi_\alpha)) \rightarrow +1$ or '+'	shift $(\phi_\beta \phi_\alpha)=+90^\circ; \theta_2 = -45^\circ$ $+\cos(2\theta_2 + (\phi_\beta - \phi_\alpha)) \rightarrow +1$ or '+' or 'Yes'
	Wrong (C1)	no shift $(\phi_\beta \phi_\alpha) = -90^\circ; \theta_1 =+45^\circ$ $-\cos(2\theta_1 + (\phi_\beta - \phi_\alpha)) \rightarrow -1$ or '-'	no shift $(\phi_\beta \phi_\alpha) = -90^\circ; \theta_2 = -45^\circ$ $+\cos(2\theta_2 + (\phi_\beta - \phi_\alpha)) \rightarrow -1$ or '-' or 'No'
C3 or bit '0' $\theta_1=+45^\circ$ $\theta_2=-45^\circ$	Correct (C3)	shift $(\phi_\beta \phi_\alpha)=+90^\circ; \theta_1 =+45^\circ$ $-\cos(2\theta_1 - (\phi_\beta - \phi_\alpha)) \rightarrow -1$ or '-'	shift $(\phi_\beta \phi_\alpha)=+90^\circ; \theta_2 = -45^\circ$ $+\cos(2\theta_2 + (\phi_\beta - \phi_\alpha)) \rightarrow +1$ or '+' or 'Yes'
	Wrong (C4)	no shift $(\phi_\beta \phi_\alpha) = -90^\circ; \theta_1 =+45^\circ$ $+\cos(2\theta_1 + (\phi_\beta - \phi_\alpha)) \rightarrow +1$ or '+'	no shift $(\phi_\beta \phi_\alpha) = -90^\circ; \theta_2 = -45^\circ$ $+\cos(2\theta_2 + (\phi_\beta - \phi_\alpha)) \rightarrow -1$ or '-' or 'No'
C4 or bit '1' $\theta_1=+45^\circ$ $\theta_2=+45^\circ$	Correct (C4)	no shift $(\phi_\beta \phi_\alpha) = -90^\circ; \theta_1 =+45^\circ$ $+\cos(2\theta_1 + (\phi_\beta - \phi_\alpha)) \rightarrow +1$ or '+'	no shift $(\phi_\beta \phi_\alpha) = -90^\circ; \theta_2 =+45^\circ$ $+\cos(2\theta_2 + (\phi_\beta - \phi_\alpha)) \rightarrow +1$ or '+' or 'Yes'
	Wrong (C3)	shift $(\phi_\beta \phi_\alpha)=+90^\circ; \theta_1 =+45^\circ$ $-\cos(2\theta_1 - (\phi_\beta - \phi_\alpha)) \rightarrow -1$ or '-'	shift $(\phi_\beta \phi_\alpha)=+90^\circ; \theta_2 =+45^\circ$ $+\cos(2\theta_2 + (\phi_\beta - \phi_\alpha)) \rightarrow -1$ or '-' or 'No'

FIG. 4: The guess-verify part showing how Bob knows Alice's guess is right or wrong for his choice of correlation in the prepare-measure part. .

guess is right or wrong. For the correlation function C1, Alice and Bob keep their projection angles $\theta_1 = +45^\circ$ and $\theta_2 = +45^\circ$ that they used in the prepare-measure part. If Alice's guess on C1 is correct through the group information Ψ sent by Bob where Bob did choose the C1 for his choice, the interference term in Alice $-\cos(2\theta_1 + (\phi_\beta - \phi_\alpha)) \rightarrow -1$, i.e., bit '0' or the '-' SPD4 will detect the ancilla photon. While the interference term in Bob $+\cos(2\theta_2 + (\phi_\beta - \phi_\alpha)) \rightarrow +1$, i.e., the '+' SPD1 will detect the signal photon which means 'Yes', so Bob knows that Alice has guessed the right correlation function C1 and hence the bit '0' for the key bit. Now, if Alice guessed C2 instead of C1, so her guess is wrong. The interference term in Alice $+\cos(2\theta_1 - (\phi_\beta - \phi_\alpha)) \rightarrow +1$ or bit '1'. Note that Alice has to apply the phase shift $\phi_\beta - \phi_\alpha = +90^\circ$ for her guess on C2 and C3 as discussed above. While the interference term in Bob $+\cos(2\theta_2 + (\phi_\beta - \phi_\alpha)) \rightarrow -1$ or the '-' SPD2 will 'click' which means 'No', so Bob knows Alice has guessed the wrong correlation or bit. From here, Bob knows the key bit set by Alice regardless Alice' guess is right or wrong. Similarly, Bob knows Alice's guess for the other correlation functions C2, C3 and C4 in the guess-verify part as

1)	1	1	1	1
2)	C3 ($\theta_1 \neq \theta_2$)	C1 ($\theta_1 = \theta_2$)	C4 ($\theta_1 = \theta_2$)	C2 ($\theta_1 \neq \theta_2$)
3)	0	0	1	1
4)	ϕ	ψ	ϕ	ψ
5)	C4 ($\theta_1 = \theta_2$)	C1 ($\theta_1 = \theta_2$)	C3 ($\theta_1 \neq \theta_2$)	C2 ($\theta_1 \neq \theta_2$)
6)	1	0	0	1
7)	No or '-'	Yes or '+'	No or '-'	Yes or '+'
8a)	1	0	0	1
8b)	x	✓	x	✓
9)	--	0	--	1

FIG. 5: The scheme for key distribution between Alice and Bob.

illustrated in Fig.4.

To illustrate the PMGV protocol more systematically, we will discuss an example of the key distribution as shown in Fig.5. Step 1-4 is for the PM part and Step 5-9 is for the GV part. Step 1: Alice sends a phase-locked signal photon to Bob by making sure the ancilla photon is detected in her '+' SPD3 or bit '1'. Alice kept the projection angle $\theta_1 = +45^\circ$. Step 2: Bob measures the signal photon based on his random choice of correlation function. He chooses C3, C1, C4 and C2 and keeps the projection angle θ_2 for each correlation function. Step 3: He obtains bit '0', '0', '1', and '1', respectively, according to Fig.2. Step 4: Bob tells Alice through classical channel about the group of his choice (Φ, Ψ), not revealing his choice of correlation function. Step 5: Alice makes guess based on which group information. Alice guesses C4, C1, C3, and C2. Step 6: Alice uses the projection angle she kept in Step 1. She measures the ancilla photon and obtains the bit '1', '0', '0', and '1' as her key bit. Step 7: Bob measures the signal photon prepared by Alice's guess by using the sequence of projection angle θ_2 he kept in Step 2. Bob knows whether Alice's guess is right ('Yes') or wrong ('No') as illustrated in Fig.4. Step 8a: Bob knows the key bits that Alice set based on her guess even though Alice's guess was wrong. Steps 8b and Step 9 are the alternative of Step 8a in the case Bob did not receive the signal photon sent by Alice. Step 8b: Bob tells Alice about his valid detection. The 'x' means no valid detection and the '✓' means valid detection. Step 9: Bob and Alice shared the remain bits as their raw secret key.

This protocol is based on the bi-partite correlation function generated through the interference of the ancilla photon in Alice and the interference of the signal photon in Bob. These interferences are spatially separated but their phases are intrinsically correlated in the laser. Since the signal photon is prepared from a highly attenuated laser light, the protocol is still vulnerable to PNS attack. The protocol is secure against PNS attack if a correlated photon-pair is used as a photon source for replacing the highly attenuated laser light. The correlated photon-pair is much easier to generate and less sensitive to decoherence than an entangled photon-pair. The high purity of correlated photon-pair at the telecom wavelengths can be generated through a four wave mixing process in a 300 m dispersion-shifted fiber (DSF). The coincidence to accidental coincidence ratio (CAR) > 100 has been achieved by suppressing the spontaneous Raman scattering process in a DSF cooled at the liquid nitrogen temperature 77K [24]. In the four wave mixing process, two pumps photon are annihilated to create energy-time correlated signal-idler photon pair. The signal and idler photons are separated from the pump photons by using a cascaded wavelength division multiplexing (WDM). The signal photon is projected to left circular polarization and sent to Bob. Similarly, the idler photon is projected to right circular polarization and sent to Alice. The right and left circular polarizations of idler/signal photons are analog to the phase-locked ancilla and signal photons when the highly attenuated laser light is used. In the guess-verify part, the polarizations of idler/signal photons are exchanged to right \rightleftharpoons left for the correlation functions C2 and C3.

Since our protocol requires coincidence detection of ancilla photon and signal photon, the highly attenuated laser light can provide the success rate of key distribution as given by $n_a n_s$, where n_a and n_s are mean photon number per pulse for the ancilla and signal photons. As for the use of a fiber based correlated photon-pair, the protocol is complete secure against PNS attack. The success rate for the key distribution is given by the production rate of the photon-pair per pulse, n_{pr} . A cooled dispersion-shifted fiber at liquid nitrogen temperature (77K) can provide the purity of photon-pair with CAR > 100 at photon-pair production rate of 0.01 per pulse. For example, if we use the commercial available (u²t) fiber mode-locked laser at repetition rate of 10 GHz [25] and a high speed low dark count superconducting single photon detector, we will obtain raw secret key bits about $0.01 \times 10^9 \times 0.01(\text{total detection efficiency}) \sim 10^5$ key bits. After applying private amplification and information reconciliation protocols, we predict to obtain about 25000 secret key bits. If a

highly attenuated laser light is used to prepare the $n_a n_s = 0.01$ per pulse for both ancilla and signal, we can have the same performance as discussed above. In ideal case, the best performance of this protocol can be achieved by replacing highly attenuated laser light or photon-pair source with two time-synchronized deterministic single photon sources, where the $n_a n_s = n_{pr} = 1.0$ per pulse. It is worth to note that the photon-pair source and two single-photon sources can increase distance of communication between two parties by factor of two.

In conclusion, we have proposed a prepare-measure-guess-verify (PMGV) protocol for key distribution using four types of single photon bi-partite correlation functions between two parties. We show that the PMGV protocol can be implemented with a highly attenuated laser light source, which is often used as alternative single photon source. Since the protocol requires coincidence detection of an ancilla photon and a signal photon, any photon-pair source or two single-photon sources can improve the success rate of key distribution, the security against PNS attack and double the communication distance in comparison to the use of highly attenuated laser light.

K.F.L would like to acknowledge the financial support as visiting professorship from University of Malaya. H.B.A gratefully acknowledges the support from the University of Malaya High Impact Research Grant (UM.C/HIR/MOHE/SC/01) on this work.

* kflee@mtu.edu

- [1] N. Gisin, G. Ribordy, W. Tittel, and H. Zbinden, *Rev. Mod. Phys.* **74**, 145 (2002).
- [2] V. Scarani, H. Bechmann-Pasquinucci, N. J Cerf, M. Dusek, N. Lutkenhaus, and M. Peev, *Rev. Mod. Phys.* **81**, 1301 (2009).
- [3] R. Ursin et al., *Nature Phys.* **3**, 481 (2007).
- [4] M. Sasaki et al., *Opt. Express* **19**, 10387 (2011).
- [5] C. H Bennett, *Phys. Rev. Lett.* **68**, 3121 (1992).
- [6] C. H Bennett, G. Brassard, and N. D Mermin, *Phys. Rev. Lett.* **68**, 557 (1992).
- [7] G. Brassard, N. Lutkenhaus, T. Mor, and B. C Sanders, *Phys. Rev. Lett.* **85**, 1330 (2000).
- [8] N. Lutkenhaus, *Phys. Rev. A* **61**, 052304 (2000).
- [9] W. Y Hwang, *Phys. Rev. Lett.* **91**, 057901 (2003).

- [10] H. W Lo, X. Ma, and K. Chen, Phys. Rev. Lett. **94**, 230504 (2005).
- [11] X. B. Wang, Phys. Rev. Lett. **94**, 230503 (2005); Y. Zhao et al., Phys. Rev. Lett. **96**, 070502 (2006); D. Rosenberg et al, Phys. Rev. Lett. **98**, 010503 (2007); C. Z. Peng et al., Phys. Rev. Lett. **98**, 010505 (2007); T. Schmitt-Manderbach et al, Phys. Rev. Lett. **98**, 010504 (2007); P. P. Arrighi, Int. Jour. Quant. Inf. **2**, 341 (2004); W. Helwig et al, Phys. Rev. A **80**, 052326 (2009).
- [12] V. Scarani, A. Acin, G. Ribordy, and N. Gisin, Phys. Rev. Lett. **92**, 057901 (2004).
- [13] H. K Lo, M. Curty, and B. Qi, Phys. Rev. Lett. **108**, 130503 (2012); K. Tamaki, H. K Lo, CH. F Fung, and B. Qi, Phys. Rev. A **85**, 042307 (2012)
- [14] W. K. Wootters, Found. Phys. **16**, 391 (1986).
- [15] K. F Lee, and J. E Thomas, Phys. Rev. Lett. **88**, 097902 (2002).
- [16] K. F Lee, and J. E Thomas, Phys. Rev. A **69**, 052311 (2004).
- [17] A. Aspect, P. Grangier, and G. Roger, Phys. Rev. Lett. **47**, 460 (1981).
- [18] J. W Pan, D. Bouwmeester, M. Daniell, H. Weinfurter, and A. Zeilinger, Nature (London) **403**, 515 (2000).
- [19] D. Bouwmeester, J. W Pan, M. Daniell, H. Weinfurter, and A. Zeilinger, Phys. Rev. Lett. **82**, 1345 (1999).
- [20] K. F Lee, Opt. Lett. **34**, 1099 (2009).
- [21] Y. M Sua, E. Scanlon, T. Beaulieu, V. Bollen, and K. F Lee, Phys. Rev. A **83**, 030302(R) (2011).
- [22] W. K Wootters, and W. H Zurek, Nature (London) **299**, 802 (1982).
- [23] C. H Bennett, and G. Brassard, in Proceedings of the IEEE International Conference on Computers, Systems and Signal Processing, Bangalore, India (IEEE, New York, 1984) , p.175.
- [24] K. F. Lee, J. Chen, C. Liang, X. Li, P. L Voss, and P. Kumar, Opt. Lett. **31**, 1905 (2006).
- [25] C. Liang, M. Shin, K. F Lee, J. Chen, and P. Kumar, Nonlinear Optics: Materials, Fundamentals and Application 2007, July 30-August 3, 2007 , Hawaii. , (2006).