

LARGE CONVEX HOLES IN RANDOM POINT SETS

JÓZSEF BALOGH, HERNÁN GONZÁLEZ-AGUILAR, AND GELASIO SALAZAR

ABSTRACT. A *convex hole* (or *empty convex polygon*) of a point set P in the plane is a convex polygon with vertices in P , containing no points of P in its interior. Let R be a bounded convex region in the plane. We show that the expected number of vertices of the largest convex hole of a set of n random points chosen independently and uniformly over R is $\Theta(\log n / (\log \log n))$, regardless of the shape of R .

1. INTRODUCTION

Let P be a set of points in the plane. A *convex hole* (alternatively, *empty convex polygon*) of P is a convex polygon with vertices in P , containing no points of P in its interior.

Questions about (empty or nonempty) convex polygons in point sets are of fundamental importance in discrete and computational geometry. A landmark in this area is the question posed by Erdős and Szekeres in 1935 [10]: “What is the smallest integer $f(k)$ such that any set of $f(k)$ points in the plane contains at least one convex k -gon?”

A variant later proposed by Erdős himself asks for the existence of empty convex polygons [11]: “Determine the smallest positive integer $H(n)$, if it exists, such that any set X of at least $H(n)$ points in general position in the plane contains n points which are the vertices of an empty convex polygon, i.e., a polygon whose interior does not contain any point of X .” It is easy to show that $H(3) = 3$ and $H(4) = 5$. Harborth [13] proved that $H(5) = 10$. Much more recently, Nicolás [17] and independently Gerken [12] proved that every sufficiently large point set contains an empty convex hexagon (see also [24]). It is currently known that $30 \leq H(6) \leq 463$ [15, 18]. A celebrated construction of Horton [14] shows that for each $n \geq 7$, $H(n)$ does not exist. For further results and references around Erdős-Szekeres type problems, we refer the reader to the surveys [1, 16] and to the monography [9].

We are interested in the expected size of convex structures in random point sets. This gives rise to a combination of Erdős-Szekeres type problems with variants of Sylvester’s seminal question [21]: “What is the probability

Date: November 11, 2018.

2010 Mathematics Subject Classification. 52C10, 60D05, 52A22, 52C05, 52A10.

Key words and phrases. Convex hole, Erdős-Szekeres Theorem, random point set.

The first author was supported by NSF CAREER Grant DMS-0745185.

The third author was supported by CONACYT grant 106432.

25 that four random points chosen independently and uniformly from a convex
 26 region form a convex quadrilateral?”

27 Several fundamental questions have been attacked (and solved) in this
 28 direction; see for instance [4, 5, 7]. Particularly relevant to our work are
 29 the results of Valtr, who computed exactly the probability that n random
 30 points independently and uniformly chosen from a parallelogram [22] or a
 31 triangle [23] are in convex position.

32 Consider a bounded convex region R , and randomly choose n points in-
 33 dependently and uniformly over R . We are interested in estimating the
 34 expected *size* (that is, number of vertices) of the largest convex hole of such
 35 a randomly generated point set.

36 Some related questions are heavily dependent on the shape of R . For
 37 instance, the expected number of vertices in the convex hull of a random
 38 point set, which is $\Theta(\log n)$ if R is the interior of a polygon, and $\Theta(n^{1/3})$
 39 if R is the interior of a convex figure with a smooth boundary (such as a
 40 disk) [19, 20]. In the problem under consideration, it turns out that the
 41 order of magnitude of the expected number of vertices of the largest convex
 42 hole is independent of the shape of R :

Theorem 1. *Let R and S be bounded convex regions in the plane. Let R_n
 (respectively, S_n) be a set of n points chosen independently and uniformly at
 random from R (respectively, S). Let $\text{HOL}(R_n)$ (respectively, $\text{HOL}(S_n)$) de-
 note the random variable that measures the number of vertices of the largest
 convex hole in R_n (respectively, S_n). Then*

$$\mathbb{E}(\text{HOL}(R_n)) = \Theta(\mathbb{E}(\text{HOL}(S_n))).$$

Moreover, *w.h.p.*

$$\text{HOL}(R_n) = \Theta(\text{HOL}(S_n)).$$

43 We remark that Theorem 1 is in line with the following result proved by
 44 Bárány and Füredi [3]: the expected number of empty simplices in a set of
 45 n points chosen uniformly and independently at random from a convex set
 46 A with non-empty interior in \mathbb{R}^d is $\Theta(n^d)$, regardless of the shape of A .

47 Using Theorem 1, we have determined the expected number of vertices of
 48 a largest convex hole up to a constant multiplicative factor:

Theorem 2. *Let R be a bounded convex region in the plane. Let R_n be a set
 of n points chosen independently and uniformly at random from R , and let
 $\text{HOL}(R_n)$ denote the random variable that measures the number of vertices
 of the largest convex hole in R_n . Then*

$$\mathbb{E}(\text{HOL}(R_n)) = \Theta\left(\frac{\log n}{\log \log n}\right).$$

Moreover, *w.h.p.*

$$\text{HOL}(R_n) = \Theta\left(\frac{\log n}{\log \log n}\right).$$

49 For the proof of Theorem 2, in both the lower and upper bounds we use
 50 powerful results of Valtr, who computed precisely the probability that n
 51 points chosen at random (from a triangle [22] or from a parallelogram [23])
 52 are in convex position. The proof of the lower bound is quite simple: we
 53 partition a unit area square R (in view of Theorem 1, it suffices to establish
 54 Theorem 2 for a square) into n/t rectangles such that each of them contains
 55 exactly t points, where $t = \frac{\log n}{2 \log \log n}$. Using [22], with high probability in at
 56 least one of the regions the points are in convex position, forming a convex
 57 hole. The proof of the upper bound is more involved. We put an n by n
 58 lattice in the unit square. The first key idea is that any sufficiently large
 59 convex hole H can be well-approximated with *lattice* quadrilaterals Q_0, Q_1
 60 (that is, their vertices are lattice points) such that $Q_0 \subseteq H \subseteq Q_1$ (see
 61 Proposition 3). The key advantage of using lattice quadrilaterals is that
 62 there are only polynomially many choices (i.e., $O(n^8)$) for each of Q_0 and
 63 Q_1 . Since H is a hole, then Q_0 contains no point of R_n in its interior. This
 64 helps to upper estimate the area $a(Q_0)$ of Q_0 , and at the same time $a(H)$
 65 and $a(Q_1)$ (see Claim B). This upper bound on $a(Q_1)$ gives that w.h.p. Q_1
 66 contains at most $O(\log n)$ points of R_n . Conditioning that each choice of Q_1
 67 contains at most $O(\log n)$ points, using Valtr [23] (dividing the (≤ 8)-gon
 68 $Q_1 \cap R$ into at most eight triangles) we prove that w.h.p. Q_1 does not contain
 69 $160 \log n / (\log \log n)$ points in convex position (Claim E), so w.h.p. there is
 70 no hole of that size. A slight complication is that Q_1 may not lie entirely in
 71 R ; this issue makes the proof somewhat more technical.

72 We make two final remarks before we move on to the proofs. As in the
 73 previous paragraph, for the rest of the paper we let $a(U)$ denote the area of
 74 a region U in the plane. We also note that, throughout the paper, by $\log x$
 75 we mean the natural logarithm of x .

76 2. PROOF OF THEOREM 1

77 Since we only consider sets of points chosen independently and uniformly
 78 at random from a region, for brevity we simply say that such set points are
 79 chosen at random from this region.

80 **Claim.** *For every $\alpha \geq 1$ and every sufficiently large n ,*

$$\mathbb{E}(\text{HOL}(R_n)) \geq (1/\alpha) \mathbb{E}(\text{HOL}(R_{\lfloor \alpha \cdot n \rfloor})).$$

81 *Proof.* Let $\alpha \geq 1$. We choose a random $\lfloor \alpha \cdot n \rfloor$ -point set $R_{\lfloor \alpha \cdot n \rfloor}$ and a random
 82 n -point set R_n over R as follows: first we choose $\lfloor \alpha \cdot n \rfloor$ points randomly
 83 from R to obtain $R_{\lfloor \alpha \cdot n \rfloor}$, and then from $R_{\lfloor \alpha \cdot n \rfloor}$ we choose randomly n points,
 84 to obtain R_n . Now if H is a convex hole of $R_{\lfloor \alpha \cdot n \rfloor}$ with vertex set $V(H)$,
 85 then $V(H) \cap R_n$ is the vertex set of a convex hole of R_n . Noting that
 86 $\mathbb{E}(|V(H) \cap R_n|) = \frac{n}{\lfloor \alpha n \rfloor} |V(H)| \geq (1/\alpha) |V(H)|$, the claim follows. \square

87 Now the expected number of vertices of the largest convex hole in a ran-
 88 dom n -point set is the same for S as for any set congruent to S . Thus

89 we may assume without loss of generality that S is contained in R . Let
 90 $\beta := a(R)/a(S)$ (thus $\beta \geq 1$), and let $0 < \epsilon \ll 1$.

91 Let $R_{\lfloor(1-\epsilon)\beta \cdot n\rfloor}$ be a set of $\lfloor(1-\epsilon)\beta \cdot n\rfloor$ points randomly chosen from R .
 92 Let $m := |S \cap R_{\lfloor(1-\epsilon)\beta \cdot n\rfloor}|$, and $\alpha := n/m$. Thus the expected value of α is
 93 $(1-\epsilon)$, and a standard application of Chernoff's inequality implies that with
 94 probability at least $1 - e^{\Omega(-n)}$ we have $1 \leq \alpha \leq (1-2\epsilon)^{-1}$. Conditioning on
 95 m means that $S_m := S \cap R_{\lfloor(1-\epsilon)\beta \cdot n\rfloor}$ is a randomly chosen m -point set in S .

96 Since $S \subseteq R$, then every convex hole in S_m is also a convex hole in
 97 $R_{\lfloor(1-\epsilon)\beta \cdot n\rfloor}$, and so

$$(1) \quad \text{HOL}(R_{\lfloor(1-\epsilon)\beta \cdot n\rfloor}) \geq \text{HOL}(S_m).$$

98 From the Claim it follows that

$$(2) \quad \mathbb{E}(\text{HOL}(R_n)) \geq ((1-\epsilon)\beta)^{-1} \mathbb{E}(\text{HOL}(R_{\lfloor(1-\epsilon)\beta \cdot n\rfloor})),$$

99 and that if $\alpha \geq 1$, then $\mathbb{E}(\text{HOL}(S_m)) \geq (1/\alpha) \mathbb{E}(\text{HOL}(S_n))$. Therefore

$$(3) \quad \mathbb{E}(\text{HOL}(S_m)) \geq (1-2\epsilon) \mathbb{E}(\text{HOL}(S_n)), \quad \text{if } 1 \leq \alpha \leq (1-2\epsilon)^{-1}.$$

100 Since $1 \leq \alpha \leq (1-2\epsilon)^{-1}$ holds with probability at least $1 - e^{\Omega(-n)}$, (1),
 101 (2), and (3) imply that $\mathbb{E}(\text{HOL}(R_n)) \geq (((1-\epsilon)\beta)^{-1}(1-2\epsilon) \mathbb{E}(\text{HOL}(S_n)) -$
 102 $ne^{\Omega(-n)})$. Therefore $\mathbb{E}(\text{HOL}(R_n)) = \Omega(\mathbb{E}(\text{HOL}(S_n)))$.

103 Reverting the roles of R and S , we obtain $\mathbb{E}(\text{HOL}(S_n)) = \Omega(\mathbb{E}(\text{HOL}(R_n)))$,
 104 and so $\mathbb{E}(\text{HOL}(R_n)) = \Theta(\mathbb{E}(\text{HOL}(S_n)))$, as claimed.

105 We finally note that it is standard to modify the proof to obtain that
 106 w.h.p. $\text{HOL}(R_n) = \Theta(\text{HOL}(S_n))$. \square

107 3. APPROXIMATING CONVEX SETS WITH LATTICE QUADRILATERALS

108 For simplicity, we shall break the proof of Theorem 2 into several steps.
 109 There is one particular step whose proof, although totally elementary, is
 110 somewhat long. In order to make the proof of Theorem 2 more readable, we
 111 devote this section to the proof of this auxiliary result.

112 In view of Theorem 1, it will suffice to prove Theorem 2 for the case when
 113 R is an isothetic unit area square. In the proof of the upper bound, we
 114 subdivide R into a n by n grid (which defines an $n+1$ by $n+1$ lattice),
 115 pick a largest convex hole H , and find lattice quadrilaterals Q_0, Q_1 such
 116 that $Q_0 \subseteq H \subseteq Q_1$, whose areas are not too different from the area of H .
 117 The caveat is that the circumscribed quadrilateral Q_1 may not completely
 118 fit into R ; for this reason, we need to extend this grid of area 1 to a grid of
 119 area 9 (that is, to extend the $n+1$ by $n+1$ lattice to a $3n+1$ by $3n+1$
 120 lattice).

121 We recall that a rectangle is *isothetic* if each of its sides is parallel to
 122 either the x - or the y -axis.

123 **Proposition 3.** *Let R (respectively, S) be the isothetic square of side length*
 124 *1 (respectively, 3) centered at the origin. Let $n > 1000$ be a positive inte-*
 125 *ger, and let \mathcal{L} be the lattice $\{(-3/2 + i/3n, -3/2 + j/3n) \in \mathbb{R}^2 \mid i, j \in$*

126 $\{0, 1, \dots, 9n\}$. Let $H \subseteq R$ be a closed convex set. Then there exists a lat-
 127 tice quadrilateral (that is, a quadrilateral each of whose vertices is a lattice
 128 point) Q_1 such that $H \subseteq Q_1$ and $a(Q_1) \leq 2a(H) + 40/n$. Moreover, if
 129 $a(H) \geq 1000/n$, then there also exists a lattice quadrilateral Q_0 such that
 130 $Q_0 \subseteq H$ and $a(Q_0) \geq a(H)/32$.

131 We remark that some lower bound on the area of H is needed in order to
 132 guarantee the existence of a lattice quadrilateral contained in H , as obviously
 133 there exist small convex sets that contain no lattice points (let alone lattice
 134 quadrilaterals).

135 *Proof.* If p, q are points in the plane, we let \overline{pq} denote the closed straight
 136 segment that joins them, and by $|\overline{pq}|$ the length of this segment (that is, the
 137 distance between p and q). We recall that if C is a convex set, the *diameter*
 138 of C is $\sup\{|\overline{xy}| : x, y \in C\}$. We also recall that a *supporting line* of C is a
 139 line that intersects the boundary of C and such that all points of C are in
 140 the same closed half-plane of the line.

141 *Existence of Q_1*

142 Let a, b be a diametral pair of H , that is, points such that $|\overline{ab}|$ equals the
 143 diameter of H (a diametral pair exists because H is closed). Now let ℓ, ℓ' be
 144 the supporting lines of H parallel to \overline{ab} .

145 Let ℓ_a, ℓ_b be the lines perpendicular to \overline{ab} that go through a and b , re-
 146 spectively. Since a, b is a diametral pair, it follows that a (respectively, b) is
 147 the only point of H that lies on ℓ_a (respectively, ℓ_b). See Figure 1.

148 Let c, d be points of H that lie on ℓ and ℓ' , respectively. Let J be the
 149 quadrilateral with vertices a, c, b, d . By interchanging ℓ and ℓ' if necessary,
 150 we may assume that a, c, b, d occur in this clockwise cyclic order in the
 151 boundary of J .

152 Let K denote the rectangle bounded by ℓ_a, ℓ, ℓ_b , and ℓ' . Let w, x, y, z be
 153 the vertices of K , labelled so that a, w, c, x, b, y, d, z occur in the boundary
 154 of K in this clockwise cyclic order. It follows that $a(K) = 2a(J)$. Since
 155 $a(H) \geq a(J)$, we obtain $a(K) \leq 2a(H)$. Let T denote the isothetic square
 156 of length side 2, also centered at the origin. It is easy to check that since
 157 $H \subseteq R$, then $K \subseteq T$.

158 Let Q_x be the square with side length $2/n$ that has x as one of its vertices,
 159 with each side parallel to ℓ or to ℓ_a , and that only intersects K at x . It is
 160 easy to see that these conditions define uniquely Q_x . Let x' be the vertex
 161 of Q_x opposite to x . Define Q_y, Q_z, Q_w, y', z' , and w' analogously.

162 Since $K \subseteq T$, it follows that Q_x, Q_y, Q_z , and Q_w are all contained in S .
 163 Using this, and the fact that there is a circle of diameter $2/n$ contained in
 164 Q_x , it follows that there is a lattice point g_x contained in the interior of Q_x .
 165 Similarly, there exist lattice points g_y, g_z , and g_w contained in the interior
 166 of Q_y, Q_z , and Q_w , respectively. Let Q_1 be the quadrilateral with vertices
 167 g_x, g_y, g_z , and g_w .

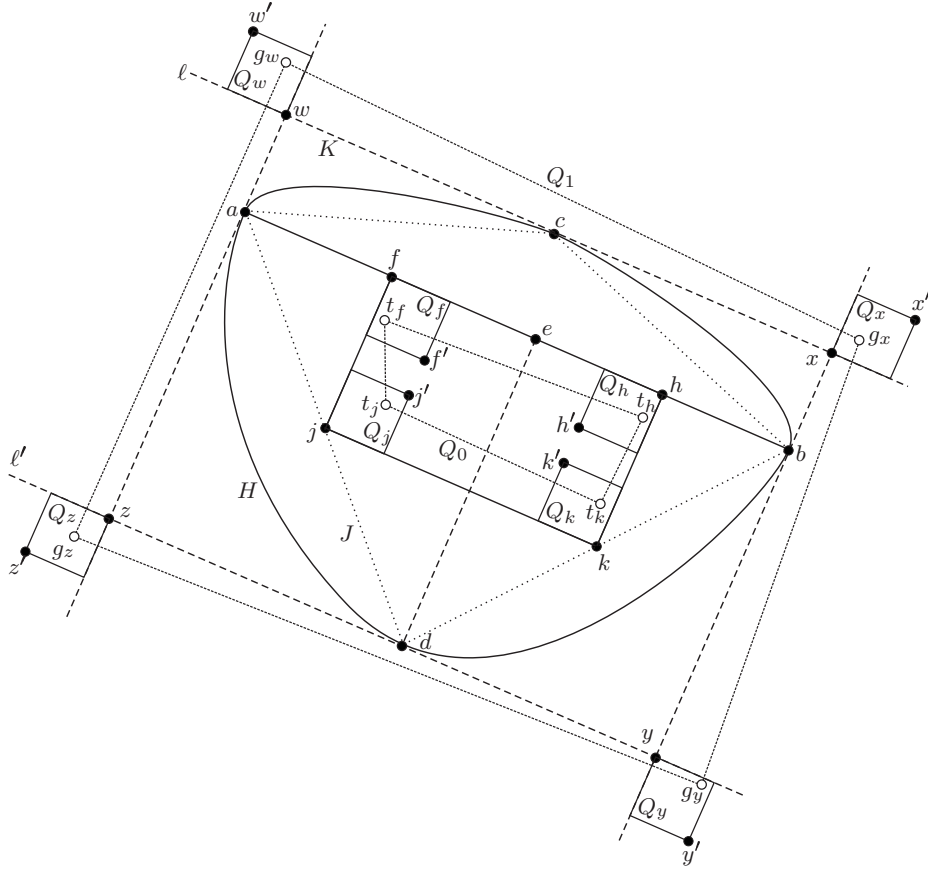

FIGURE 1. Lattice quadrilateral Q_1 has vertices g_w, g_x, g_y, g_z , and lattice quadrilateral Q_0 has vertices t_f, t_h, t_j, t_k .

168 Let $\text{per}(K)$ denote the perimeter of K . The area of the rectangle K'
 169 with vertices w', x', y', z' (see Figure 1) is $a(K) + \text{per}(K)(2/n) + 4(2/n)^2$.
 170 Since the perimeter of any rectangle contained in S is at most 12, then
 171 $a(K') \leq a(K) + 24/n + 16/n^2 \leq a(K) + 40/n$. Since $a(Q_1) \leq a(K')$, we
 172 obtain $a(Q_1) \leq a(K) + 40/n \leq 2a(H) + 40/n$.

173 *Existence of Q_0*

174 Suppose without any loss of generality (relabel if needed) that the area
 175 of the triangle $\Delta := abd$ is at least the area of the triangle abc . Since
 176 $2a(J) = a(K) \geq a(H)$ and $a(\Delta) \geq a(J)/2$, we have $a(\Delta) \geq a(H)/4$. By
 177 hypothesis $a(H) \geq 1000/n$, and so $a(\Delta) \geq 1000/(4n)$.

178 Since a, b is a diametral pair, it follows that the longest side of Δ is \overline{ab} .
 179 Let e be the intersection point of \overline{ab} with the line perpendicular to \overline{ab} that
 180 passes through d . Thus $a(\Delta) = |\overline{ab}||\overline{de}|/2$. See Figure 1.

181 There exists a rectangle U , with base contained in \overline{ab} , whose other side
 182 has length $|\overline{de}|/2$, and such that $a(U) = a(\Delta)/2$. Let f, h, j, k denote the
 183 vertices of this rectangle, labelled so that f and h lie on \overline{ab} (with f closer
 184 to a than h), j lies on \overline{ad} , and k lies on \overline{bd} . Thus $|\overline{fj}| = |\overline{de}|/2$.

185 Now $|\overline{ab}| < 2$ (indeed, $|\overline{ab}| \leq \sqrt{2}$, since a, b are both in R), and since
 186 $|\overline{ab}||\overline{de}|/2 = a(\Delta) \geq 1000/(4n)$ it follows that $|\overline{de}| \geq 1000/(4n)$. Thus
 187 $|\overline{fj}| \geq 1000/(8n)$.

188 Now since a, b is a diametral pair it follows that $a(K) \leq |\overline{ab}|^2$. Using
 189 $1000/n \leq a(H) \leq a(K)$, we obtain $1000/n \leq |\overline{ab}|^2$. Note that $|\overline{fh}| = |\overline{ab}|/2$.
 190 Thus $1000/(4n) \leq |\overline{fh}|^2$. Using $|\overline{fh}| = |\overline{ab}|/2$ and $|\overline{ab}| \leq \sqrt{2}$, we obtain
 191 $|\overline{fh}| < 1$, and so $|\overline{fh}| > |\overline{fh}|^2 \geq 1000/(4n)$.

192 Now let Q_f be the square with sides of length $2/n$, contained in U , with
 193 sides parallel to the sides of U , and that has f as one of its vertices. Let f' de-
 194 note the vertex of Q_f that is opposite to f . Define similarly Q_h, Q_j, Q_k, h', j' ,
 195 and k' .

196 Since $|\overline{fj}|$ and $|\overline{fh}|$ are both at least $1000/(8n)$, it follows that the squares
 197 Q_f, Q_h, Q_j, Q_k are pairwise disjoint. Since the sides of these squares are all
 198 $2/n$, it follows that each of these squares contains at least one lattice point.
 199 Let t_f denote a lattice point contained in Q_f ; define t_h, t_j , and t_k analogously.

200 Let Q_0 denote the quadrilateral with vertices t_f, t_h, t_j , and t_k . Let W
 201 denote the rectangle with vertices f', h', j' , and k' .

202 Since $|\overline{fj}|$ and $|\overline{fh}|$ are both at least $1000/(8n)$, and the side lengths of
 203 the squares Q are $2/n$, it follows easily that $|\overline{f'h'}| > (1/2)|\overline{fh}|$ and $|\overline{j'k'}| >$
 204 $(1/2)|\overline{jk}|$. Thus $a(W) > a(U)/4$. Now clearly $a(Q_0) \geq a(W)$. Recalling that
 205 $a(U) = a(\Delta)/2$, $a(\Delta) \geq a(J)/2$, and $a(J) = a(K)/2 \geq a(H)/2$, we obtain
 206 $a(Q_0) \geq a(U)/4 \geq a(\Delta)/8 \geq a(J)/16 \geq a(H)/32$. \square

207

4. PROOF OF THEOREM 2

208 As in the proof of Theorem 1, for brevity, since we only consider sets
 209 of points chosen independently and uniformly at random from a region, we
 210 simply say that such set points are chosen at random from the region.

211 We prove the lower and upper bounds separately.

212 *Proof of the lower bounds.* In view of Theorem 1, we may assume without
 213 any loss of generality that R is a square. Let R_n be a set of n points chosen
 214 at random from R . We will prove that w.h.p. R_n has a convex hole of size at
 215 least t , where $t := \frac{\log n}{2 \log \log n}$. Let $k := n/t$. For simplicity, suppose that both
 216 t and k are integers. Let $\{\ell_0, \ell_1, \ell_2, \dots, \ell_k\}$ be a set of vertical lines disjoint
 217 from R_n , chosen so that for $i = 0, 1, 2, \dots, k-1$, the set R_n^i of points of R_n
 218 contained in the rectangle R^i bounded by R, ℓ_i , and ℓ_{i+1} contains exactly t

219 points. Conditioning that R^i contains exactly t points we have that these t
 220 points are chosen at random from R^i .

Valtr [22] proved that the probability that r points chosen at random
 in a parallelogram are in convex position is $\left(\frac{\binom{2r-2}{r-1}}{r!}\right)^2$. Using the bounds
 $\binom{2s}{s} \geq 4^s/(s+1)$ and $s! \leq es^{s+1/2}e^{-s}$, we obtain that this is at least r^{-2r}
 for all $r \geq 3$:

$$\left(\frac{\binom{2r-2}{r-1}}{r!}\right)^2 \geq \left(\frac{4^{r-1}}{er^r\sqrt{r}e^{-r}}\right)^2 = \frac{(4e)^{2r}}{16e^2r^3} \cdot r^{-2r}.$$

Since each R^i is a rectangle containing t points chosen at random, it
 follows that for each fixed $i \in \{0, 1, \dots, k-1\}$, the points of R_n^i are in
 convex position with probability at least t^{-2t} . Since there are $k = n/t$ sets
 R_n^i , it follows that none of the sets R_n^i is in convex position with probability
 at most

$$(1 - t^{-2t})^{n/t} \leq e^{-\frac{n}{t}t^{-2t}} = e^{-nt^{-2t-1}}.$$

221 If the $t = \log n/(2 \log \log n)$ points of an R_n^i are in convex position,
 222 then they form a convex hole of R_n . Thus, the probability that there
 223 is a convex hole of R_n of size at least $\log n/(2 \log \log n)$ is at least $1 -$
 224 $e^{-nt^{-2t-1}}$. Since $e^{-nt^{-2t-1}} \rightarrow 0$ as $n \rightarrow \infty$, it follows that w.h.p. $\text{HOL}(R_n) =$
 225 $\Omega(\log n/(\log \log n))$.

226 For the lower bound of $\mathbb{E}(\text{HOL}(R_n))$, we use once again that $\mathbb{P}(\text{HOL}(R_n) \geq$
 227 $\log n/(2 \log \log n)) \geq 1 - e^{-nt^{-2t-1}}$. Since $\text{HOL}(R_n)$ is a non-negative random
 228 variable, it follows that $\mathbb{E}(\text{HOL}(R_n)) = \Omega(\log n/(\log \log n))$. \square

229 *Proof of the upper bounds.* We remark that throughout the proof we always
 230 implicitly assume that n is sufficiently large. We start by stating a straight-
 231 forward consequence of Chernoff's bound. This is easily derived, for in-
 232 stance, from Theorem A.1.11 in [2].

Lemma 4. *Let X_1, \dots, X_r be mutually independent random variables with*
 $\mathbb{P}(X_i = 1) = p$ *and* $\mathbb{P}(X_i = 0) = 1 - p$, *for* $i = 1, \dots, r$. *Let* $X :=$
 $X_1 + \dots + X_r$. *Then, for any* $s \geq r$ *and* $q \geq p$,

$$\mathbb{P}(X \geq (3/2)qs) < e^{-qs/16}. \quad \square$$

233 In view of Theorem 1, we may assume without any loss of generality that
 234 R is a (any) square. Aiming to invoke directly Proposition 3, we take as
 235 R the isothetic unit area square centered at the origin, and let S be the
 236 isothetic square of area 9, also centered at the origin.

237 Let n be a (large) positive integer. Let R_n be a set of n points chosen at
 238 random from R .

239 To establish the upper bound, we will show that w.h.p. the largest convex
 240 hole in R_n has less than $160 \log n/(\log \log n)$ vertices.

241 Recall that \mathcal{L} is the lattice $\{(-3/2 + i/3n, -3/2 + j/3n) \in \mathbb{R}^2 \mid i, j \in$
 242 $\{0, 1, \dots, 9n\}\}$. A point in \mathcal{L} is a *lattice point*. A *lattice quadrilateral* is a
 243 quadrilateral each of whose vertices is a lattice point. Now there are $(9n+1)^2$
 244 lattice points, and so there are fewer than $(9n)^8$ lattice quadrilaterals in
 245 total, and fewer than n^8 lattice quadrilaterals whose four vertices are in R .

246 **Claim A.** *With probability at least $1 - n^{-10}$ the random point set R_n has the*
 247 *property that every lattice quadrilateral Q with $a(Q) < 2000 \log n/n$ satisfies*
 248 *that $|R_n \cap Q| \leq 3000 \log n$.*

249 *Proof.* Let Q be a lattice quadrilateral with $a(Q) < 2000 \log n/n$. Let X_Q
 250 denote the random variable that measures the number of points of R_n in Q .
 251 We apply Lemma 4 with $p = a(Q \cap R) \leq q = (2000 \log n)/n$, and $r = s = n$
 252 to obtain $\mathbb{P}(X_Q > 3000 \log n) < e^{-125 \log n} = n^{-125}$. As the number of
 253 choices for Q is at most $(9n)^8$, with probability at least $(1 - 9n^8 \cdot n^{-125}) >$
 254 $1 - n^{-10}$ no such Q contains more than $3000 \log n$ points of R_n . \square

255 A polygon is *empty* if its interior contains no points of R_n .

256 **Claim B.** *With probability at least $1 - n^{-10}$ the random point set R_n*
 257 *has the property that there is no empty lattice quadrilateral $Q \subseteq R$ with*
 258 *$a(Q) \geq 20 \log n/n$.*

259 *Proof.* The probability that a fixed lattice quadrilateral $Q \subseteq R$ with $a(Q) \geq$
 260 $20 \log n/n$ is empty is $(1 - a(Q))^n < n^{-20}$. Since there are fewer than n^8
 261 lattice quadrilaterals in R , it follows that the probability that at least one of
 262 the lattice quadrilaterals with area at least $20 \log n/n$ is empty is less than
 263 $n^8 \cdot n^{-20} < n^{-10}$. \square

264 Let H be a maximum size convex hole of R_n . We now transcribe the
 265 conclusion of Proposition 3 for easy reference within this proof.

266 **Claim C.** *There exists a lattice quadrilateral Q_1 such that $H \subseteq Q_1$ and*
 267 *$a(Q_1) \leq 2a(H) + 40/n$. Moreover, if $a(H) \geq 1000/n$, then there is a lattice*
 268 *quadrilateral Q_0 such that $Q_0 \subseteq H$ and $a(Q_0) \geq a(H)/32$.* \square

269 **Claim D.** *With probability at least $1 - 2n^{-10}$ we have $a(Q_1) < 2000 \log n/n$*
 270 *and $|R_n \cap Q_1| \leq 3000 \log n$.*

271 *Proof.* By Claim A, it suffices to show that with probability at least $1 - n^{-10}$
 272 we have that $a(Q_1) < 2000 \log n/n$.

273 Suppose first that $a(H) < 1000/n$. Then $a(Q_1) \leq 2a(H) + 40/n <$
 274 $2040/n$. Since $2040/n < 2000 \log n/n$, in this case we are done.

275 Now suppose that $a(H) \geq 1000/n$, so that Q_0 (from Claim C) exists.
 276 Moreover, $a(Q_1) \leq 2a(H) + 40/n < 3a(H)$. Since $Q_0 \subseteq H$, and H is a
 277 convex hole of R_n , it follows that Q_0 is empty. Thus, by Claim B, with
 278 probability at least $1 - n^{-10}$ we have that $a(Q_0) < 20 \log n/n$. Now since

279 $a(Q_1) < 3a(H)$ and $a(Q_0) \geq a(H)/32$, it follows that $a(Q_1) \leq 96a(Q_0)$.
 280 Thus with probability at least $1 - n^{-10}$ we have that $a(Q_1) \leq 96 \cdot 20 \log n/n <$
 281 $2000 \log n/n$. \square

282 We now derive a bound from an exact result by Valtr [23].

283 **Claim E.** *The probability that r points chosen at random from a triangle*
 284 *are in convex position is at most r^{-r} , for all sufficiently large r .*

285 *Proof.* Valtr [23] proved that the probability that r points chosen at random
 286 in a triangle are in convex position is $2^r(3r-3)!/((r-1)!^3(2r)!)$. Using
 287 the bounds $(s/e)^s < s! \leq e s^{s+1/2} e^{-s}$, we obtain

$$\frac{2^r(3r-3)!}{((r-1)!^3(2r)!)} < \frac{2^r(3r)!}{(r!)^3(2r)!} \leq \frac{2^r 3(3r)^{3r} \sqrt{3r} e^{-3r}}{r^{3r} e^{-3r} (2r)^{2r} e^{-2r}} < \sqrt{27r} \left(\frac{27e^2}{2r^2} \right)^r < r^{-r},$$

288 where the last inequality holds for all sufficiently large r . \square

289 For each lattice quadrilateral Q , the polygon $Q \cap R$ has at most eight
 290 sides, and so it can be partitioned into at most eight triangles. For each
 291 Q , we choose one such decomposition into triangles, which we call the *basic*
 292 triangles of Q . Note that there are fewer than $8(9n)^8$ basic triangles in total.

293 **Claim F.** *With probability at least $1 - 2n^{-10}$ the random point set R_n*
 294 *satisfies that no lattice quadrilateral Q with $a(Q) < 2000 \log n/n$ contains*
 295 *$160 \log n/(\log \log n)$ points of R_n in convex position.*

296 *Proof.* Let \mathcal{T} denote the set of basic triangles obtained from lattice quadri-
 297 laterals that have area at most $2000 \log n/n$. By Claim A, with probability
 298 at least $1 - n^{-10}$ every $T \in \mathcal{T}$ satisfies $|R_n \cap T| \leq 3000 \log n$. Thus it
 299 suffices to show that the probability that there exists a $T \in \mathcal{T}$ with
 300 $|R_n \cap T| \leq 3000 \log n$ and $20 \log n/(\log \log n)$ points of R_n in convex position
 301 is at most n^{-10} .

302 Let $T \in \mathcal{T}$ be such that $|R_n \cap T| \leq 3000 \log n$, and let $i := |R_n \cap T|$.
 303 Conditioning on i means that the i points in $R_n \cap T$ are randomly distributed
 304 in T . By Claim E, the expected number of r -tuples of R_n in T in convex
 305 position is at most $\binom{i}{r} r^{-r} \leq \binom{3000 \log n}{r} r^{-r} < (9000 r^{-2} \log n)^r$. Since there
 306 are at most $8(9n)^8$ choices for T , it follows that the expected total number
 307 of such r -tuples (over all $T \in \mathcal{T}$) with $r = 20 \log n/(\log \log n)$ is at most $8(9n)^8$
 308 $\cdot (9000 r^{-2} \log n)^r < n^{-10}$. Hence the probability that one such r -tuple exists
 309 (that is, the probability that there exists a $T \in \mathcal{T}$ with $20 \log n/(\log \log n)$
 310 points of R_n in convex position) is at most n^{-10} . \square

311 Now we are prepared to complete the proof of the upper bound. Recall
 312 that H is a maximum size convex hole of R_n , and that $H \subseteq Q_1$. It follows
 313 immediately from Claims D and F that with probability at least $1 - 4n^{-10}$
 314 the quadrilateral Q_1 does not contain a set of $160 \log n/(\log \log n)$ points of

315 R_n in convex position. In particular, with probability at least $1 - 4n^{-10}$
 316 the size of H is at most $160 \log n / (\log \log n)$. Therefore w.h.p. $\text{HOL}(R_n) =$
 317 $O(\log n / (\log \log n))$.

318 Finally, for the upper bound of $\mathbb{E}(\text{HOL}(R_n))$, we use once again that
 319 with probability at least $1 - 4n^{-10}$, $\text{HOL}(R_n) \leq 160 \log n / (\log \log n)$. Since
 320 obviously the size of the largest convex hole of R_n is at most n , it follows at
 321 once that $\mathbb{E}(\text{HOL}(R_n)) = O(\log n / (\log \log n))$. \square

322 5. CONCLUDING REMARKS

323 The lower and upper bounds we found in the proof of Theorem 2 for the
 324 case when R is a square (we proved that w.h.p. $(1/2) \log n / (\log \log n) \leq$
 325 $\text{HOL}(R_n) \leq 160 \log n / (\log \log n)$) are not outrageously far from each other.
 326 We made no effort to optimize the 160 factor, and with some additional work
 327 this could be improved. Our belief is that the correct constant is closer to
 328 $1/2$ than to 160, and we would not be surprised if $1/2$ were proved to be the
 329 correct constant.

330 There is great interest not only in the existence, but also on the number
 331 of convex holes of a given size (see for instance [6]). Along these lines, let
 332 us observe that a slight modification of our proof of Theorem 2 yields the
 333 following statement. The details of the proof are omitted.

334 **Proposition 5.** *Let R_n be a set of n points chosen independently and uni-*
 335 *formly at random from a square. Then, for any positive integer s , the number*
 336 *of convex holes of R_n of size s is w.h.p. at most n^9 .*

337 We made no effort to improve the exponent of n in this statement.

338 Moreover, for “large” convex holes we can also give lower bounds. Indeed,
 339 our calculations can be easily extended to show that for every sufficiently
 340 small constant c , there is an $\epsilon(c)$ such that the number of convex holes of
 341 size at least $c \cdot \log n / (\log \log n)$ is at most n^8 and at least $n^{1-\epsilon(c)}$.

342 ACKNOWLEDGMENTS

343 This project initially evolved from conversations of the third author with
 344 Ruy Fabila-Monroy. We thank him for these fruitful exchanges, and for
 345 several insightful remarks and corrections on this manuscript. We also thank
 346 Ferran Hurtado for sharing with us his expertise and providing guidance at
 347 the beginning of the project. He pointed us in the right direction by bringing
 348 to our attention the importance of settling the (ir)relevance of the shape of
 349 the convex sets under consideration.

350 REFERENCES

- 351 [1] O. Aichholzer. [Empty] [colored] k -gons. Recent results on some Erdős-Szekeres
 352 type problems. In *Proc. XIII Encuentros de Geometría Computacional*, pp. 43–52,
 353 Zaragoza, Spain, 2009.
 354 [2] N. Alon and J. Spencer. *The probabilistic method*, 3rd. Edition. Wiley, 2008.

- 355 [3] I. Bárány and Z. Füredi, Empty simplices in Euclidean space, *Canad. Math. Bull.* **30**
 356 (1987) 436–445.
- 357 [4] I. Bárány and G. Ambrus, Longest convex chains, *Random Structures and Algorithms*
 358 **35** (2009), 137–162.
- 359 [5] I. Bárány, Sylvester’s question: the probability that n points are in convex position,
 360 *Ann. Probab.* **27** (1999), 2020–2034.
- 361 [6] I. Bárány and P. Valtr, Planar point sets with a small number of empty convex
 362 polygons. *Studia Sci. Math. Hungar.* **41** (2004), 243–266.
- 363 [7] C. Buchta, The exact distribution of the number of vertices of a random convex chain,
 364 *Mathematika* **53** (2006), 247–254.
- 365 [8] P. Brass, Empty monochromatic fourgons in two-colored points sets. *Geombinatorics*
 366 **XIV(1)** (2004), 5–7.
- 367 [9] P. Brass, W. Moser, and J. Pach, *Research Problems in Discrete Geometry*. Springer,
 368 2005.
- 369 [10] P. Erdős and G. Szekeres, A combinatorial problem in geometry. *Compositio Math.*
 370 **2** (1935), 463–470.
- 371 [11] P. Erdős, Some more problems on elementary geometry. *Austral. Math. Soc. Gaz.* **5**
 372 (1978), 52–54.
- 373 [12] T. Gerken, Empty convex hexagons in planar point sets. *Discrete Comput. Geom.* **39**
 374 (2008), 239–272.
- 375 [13] H. Harborth, Konvexe Fünfecke in ebenen Punktmengen, *Elem. Math.* **33** (1978),
 376 116–118.
- 377 [14] J.D. Horton, Sets with no empty convex 7-gons, *Canad. Math. Bull.* **26** (1983), 482–
 378 484.
- 379 [15] V.A. Koshelev, The Erdős-Szekeres problem. *Dokl. Math.* **76** (2007), 603–605.
- 380 [16] W. Morris and V. Soltan, The Erdős-Szekeres problem on points in convex position
 381 — a survey. *Bull. Amer. Math. Soc.* **37** (2000), 437–458.
- 382 [17] C. Nicolás, The empty hexagon theorem. *Discrete Comput. Geom.* **38** (2007), 389–
 383 397.
- 384 [18] M. Overmars, Finding sets of points without empty convex 6-gons. *Discrete Comput.*
 385 *Geom.* **29** (2003), 153–158.
- 386 [19] A. Rényi and R. Sulanke, Über die konvexe Hülle von n zufällig gewählten Punkten.
 387 *Z. Wahrscheinlichkeitstheorie und Verw. Gebiete* **2** (1963), 75–84.
- 388 [20] A. Rényi and R. Sulanke, Über die konvexe Hülle von n zufällig gewählten Punkten.
 389 II. *Z. Wahrscheinlichkeitstheorie und Verw. Gebiete* **3** (1964), 138–147.
- 390 [21] J.J. Sylvester, Question 1491. *The Educational Times*, (London). April 1864.
- 391 [22] P. Valtr, Probability that n Random Points are in Convex Position. *Discrete and*
 392 *Computational Geometry* **13** (1995), 637–643.
- 393 [23] P. Valtr, The Probability that n Random Points in a Triangle Are in Convex Position.
 394 *Combinatorica* **16** (1996), 567–573.
- 395 [24] P. Valtr, On Empty Hexagons. In: J. E. Goodman, J. Pach, and R. Pollack, *Surveys*
 396 *on Discrete and Computational Geometry, Twenty Years Later*. *Contemp. Math.* **453**,
 397 AMS, 2008, pp. 433–441.

398 UNIVERSITY OF ILLINOIS AT URBANA-CHAMPAIGN, USA.
 399 *E-mail address:* jobal@math.uiuc.edu

400 FACULTAD DE CIENCIAS, UASLP. SAN LUIS POTOSI, MEXICO.
 401 *E-mail address:* hernan@fc.uaslp.mx

402 INSTITUTO DE FÍSICA, UASLP. SAN LUIS POTOSI, MEXICO.
 403 *E-mail address:* gsalazar@ifisica.uaslp.mx