

# TRANSISTOR AS A RECTIFIER

Raju Baddi

National Center for Radio Astrophysics, TIFR, Ganeshkhind, P.O.Bag 3, PUNE 411007.

## Abstract

Transistor is a three terminal semiconductor device normally used as an amplifier or as a switch. Here the alternating current(a.c) rectifying property of the transistor is considered. The ordinary silicon diode exhibits a voltage drop of  $\sim 0.6V$  across its terminals. In this article it is shown that the transistor can be used to build a diode or rectify low current a.c( $\sim mA$ ) with a voltage drop of  $\sim 0.03V$ . This voltage is  $\sim 20$  times smaller than the silicon diode. The article gives the half-wave and full-wave transistor rectifier configurations along with some applications to justify their usefulness.

## 1 Introduction

Rectification of a.c is normally carried out using silicon diodes(Kasatkin & Nemtsov 1986). The silicon diode exhibits a voltage drop of  $\sim 0.6V$  across its terminals when forward biased. This  $0.6V$  is very small voltage if one wants to rectify voltages like  $10V$  or  $100V$  and hence the voltage drop across the diode can be neglected. The diode for all practical purposes is considered to conduct freely in one direction and completely non-conducting in the other direction(reverse bias). However if one needs to rectify a.c of amplitude  $1V$ , the  $0.6V$  across the silicon diode forms a large fraction( $60\%$ ). Essentially the silicon diode cannot be used to rectify low voltage a.c( $\sim 1V$ ) if one is interested in recovering the complete or almost complete( $90\%$ ) waveform of the signal. In this article the possibility of using a transistor as a rectifier(Pookaiyaudom et.al) is explored. It is seen that the transistor rectifier exhibits a voltage drop of  $0.03V$  or in other words it forms a diode with this voltage drop. This voltage is 20 times smaller compared to the silicon diode and 5 times smaller compared to the schottky diode( $0.15V$ ). Thus the transistor rectifier can be used to rectify a.c as low as 10 times the voltage drop across it,  $\sim 300mV$ . This article gives half-wave and full-wave configurations of the transistor rectifier as shown in Figures 1 and 2 respectively.

## 2 The Transistor Rectifier

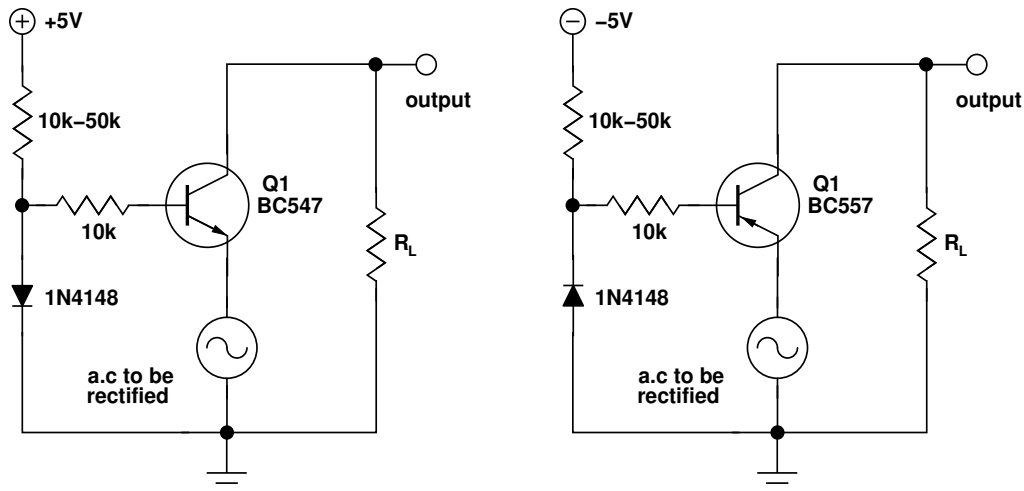

Figure 1: Left: NPN version of transistorized a.c rectifier which passes the -ve half cycles. Right: PNP version of this circuit would pass the +ve half cycles. The rectified d.c would appear across the load resistor  $R_L$ . Refer Figure 3 for computer simulation results.

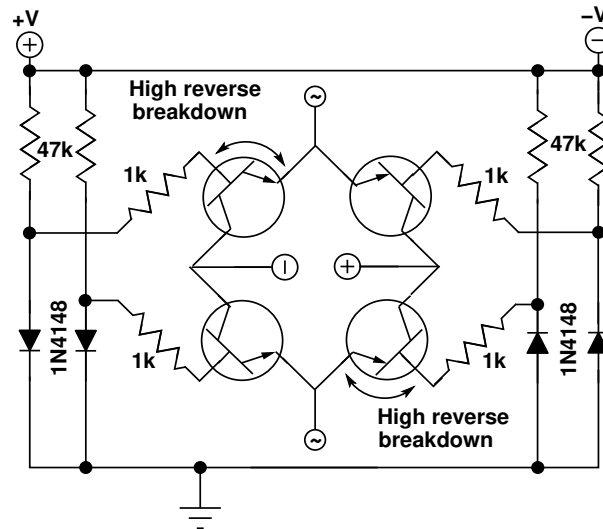

Figure 2: A transistorized bridge rectifier using 2-NPN and 2-PNP transistors replacing the diodes in the standard configuration. The biasing to the transistors is obtained from the voltage drop across the diodes (1N4148) in the side arms. The transistors should have high reverse breakdown voltage for BE junction. The supply voltage( $\pm V$ ) should be less than this reverse breakdown voltage.

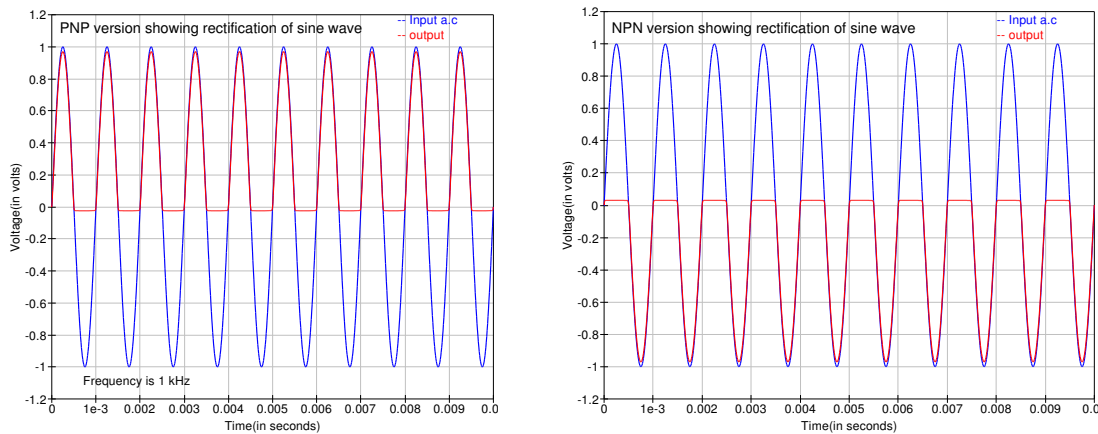

Figure 3: Transistorized Rectifier Simulations: Half wave rectifier with a 1V pk-pk and 1kHz ac input. Left: PNP version which rectifies positive half cycle. Right: NPN version that rectifies negative half cycle. Simulations in linux QUCs.

Rectification of alternating current with a single transistor has been considered. This simple circuit consisting of a transistor, a biasing diode and a few resistors can rectify a.c as low as 0.3V or even smaller. The rectification can be for positive half cycle or negative half cycle depending on the type of transistor(pnp/npn respectively) chosen. The schematic circuit of the rectifier is as shown in Figure-1. The quiescent forward biasing(Kasatkin & Nemtsov 1986) of the base-emitter junction of the transistors is taken care by the voltage drop across the silicon diodes(1N4148) in the side arms. The base-emitter junction of the silicon transistor and the silicon diode being similar the voltage drops across them are also more or less equal. The a.c to be rectified is introduced in the emitter circuit as shown in the Figure-1. Under these conditions any low negative voltage(NPN-version) appearing at the emitter would set up an emitter current which would mostly flow to the collector. However a small voltage drop( $\sim 0.03V$ ) across collector and emitter of the transistor is required to maintain this current. Essentially any additional voltage in the emitter circuit other than the balanced out voltage drops of the silicon diode and the base-emitter junction will be transferred to the collector circuit dropping across the load  $R_L$ , as most of the emitter current flows to the collector. The Figure-1 shows both types of rectifiers which can rectify either the negative phase or the positive phase of the a.c signal. A full wave bridge rectifier using four transistors is shown in Figure-2. The results of computer simulation are shown in Figure-3. During the opposite phase i.e positive voltage w.r.t ground for NPN-version the base-emitter junction would be reverse biased however the base-collector junction is

forward biased with the voltage drop across the biasing diode which is insufficient to setup a current through  $R_L$ . Thus the circuit behaves as a rectifier passing only one phase of the a.c. The following appendix gives analysis and applications of the transistor rectifier.

## A Analysis of the Rectifier

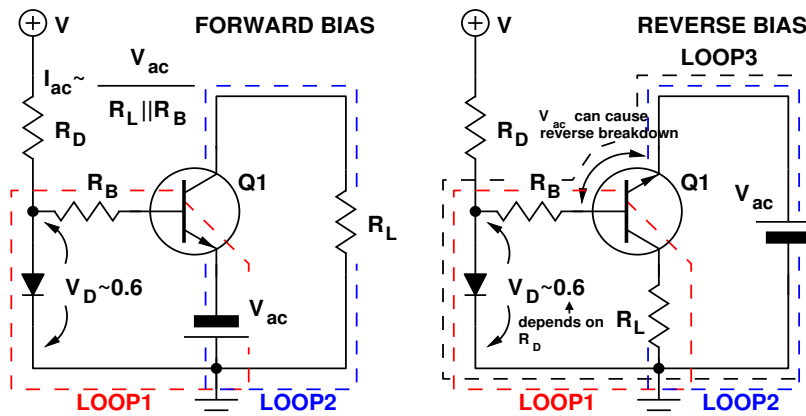

Figure 4: Forward(left) and Reverse(right) bias configurations of the transistor rectifier. During forward bias  $V_{ac}$  sees loops 1 and 2 and current flows in both the loop resistors. Essentially  $V_{ac}$  sees an impedance of  $R_B || R_L$  (when  $R_D$  is sufficiently low, else impedance is higher). If  $R_B$  is considerably higher than  $R_L$  then impedance is  $\sim R_L$ . Under reverse bias the configuration is similar to a voltage follower circuit but with emitter in place of collector and viceversa. As the voltage drop across the biasing diode is just sufficient for the BC junction only a weak constant current flows through  $R_L$  which can be seen in Figure 3 as a weak leakage during the cutoff phase of the a.c.

The forward bias and reverse bias operation of the NPN transistor rectifier are understood as shown in Figure 4. During forward bias(left figure) the voltage drop across the biasing diode  $V_D \sim 0.6V$  supplies the necessary base-emitter voltage drop for Q1. The negative voltage  $V_{ac}$  w.r.t ground during this phase sees the LOOP1 and a current  $\sim V_{ac}/R_B$  should flow through  $R_B$ . This causes a voltage drop of  $\sim V_{ac}$  across  $R_B$ . It is assumed that  $V_{ac}/R_B$  is drawn from the biasing diode's (assuming  $R_D$  is sufficiently low, however if  $R_D$  is high then current through  $R_B$  can be lower) current which can only cause a small change in its voltage drop as per its I-V characteristics.  $V_{ac}$  also sets up current  $V_{ac}/R_L$  in the load resistor. If  $V_{ac}$  is further increased it can even lead to reversing the voltage drop across the biasing diode (impedance :  $V_{ac}(R_D + R_B)/(V_{ac} + V) || R_L$ ). However the upper limit on  $V_{ac}$  is set by the reverse break down of BE junction (loop 3) which would be unfavourable for the life of the transistor. Further the value of  $R_D$  plays a role in the reverse leakage current which is seen as a small constant voltage during the cutoff phase of ac (Figure 3). Smaller the value of  $R_D$  higher is the voltage drop across biasing diode and more will be the leakage. The same is true for  $R_B$  as well, however  $R_B$  also plays a role in impedance seen by  $V_{ac}$ . During reverse bias (Figure 4, right) the configuration is similar to that of a voltage follower however with the emitter replacing the collector and viceversa. Under this condition the voltage drop across the biasing diode is just sufficient to supply the BC junction forward biasing and not much is left for the voltage drop across  $R_L$  if a current starts flowing through it. However a weak current can still flow through  $R_L$  which depends on the voltage drop across the diode and in turn on the value of  $R_D$ . This leakage is seen in Figure 3 as a small constant voltage  $\sim$  few 10mV. The following sections give applications of the transistor rectifier.

### A.1 Small signal AC voltmeter

The half wave rectifier in Figure 1 can be used to build a simple a.c voltmeter (Figure 6) which can measure a.c voltages as low as 0.3V which using conventional 600mV voltage drop silicon diode is not possible, however one can still use a schottky diode ( $\sim 150mV$ ). The transistor gives a much smaller (5 times) voltage drop across its CE terminals and acts as a diode with  $\sim 30mV$  voltage drop. The schematic circuit diagram of the a.c voltmeter is as shown in Figure 5.

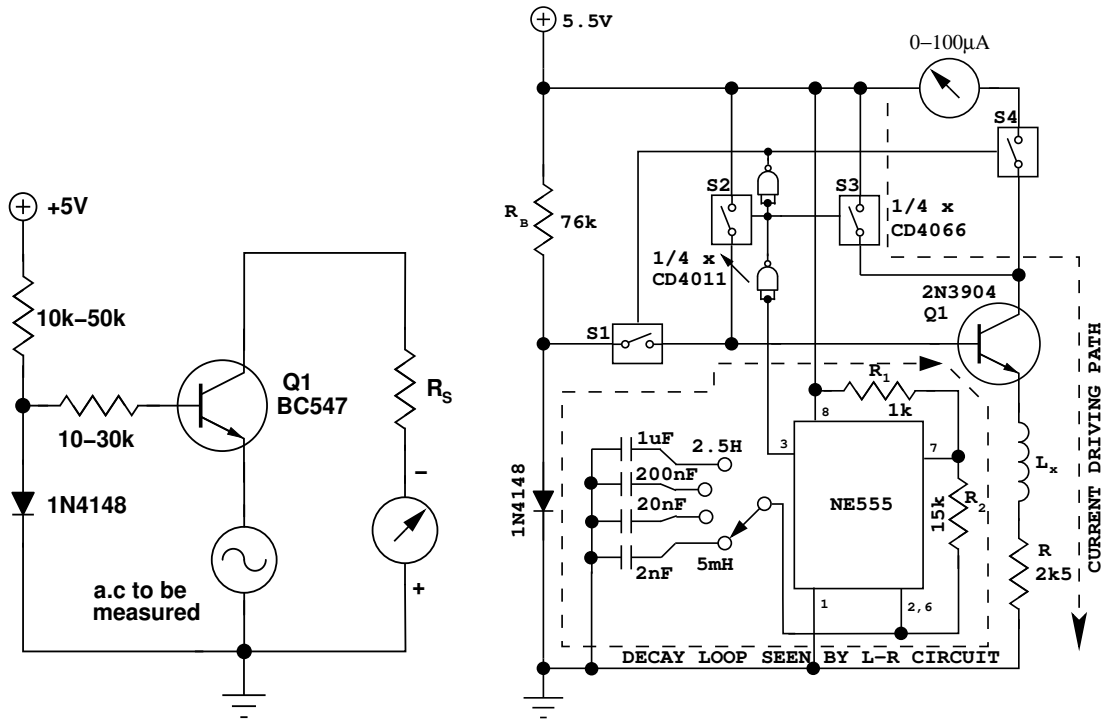

Figure 5: Left: Small signal a.c. voltmeter. Resistor  $R_S$  is chosen such that full scale deflection corresponds to chosen range of the instrument.  $R_S$  can be either chosen by trial and error or calculated assuming the transistor to be an ideal rectifier. Right: Inductance Meter using the half wave transistor rectifier (Copyright © 2013 UBM. Reprinted with permission.).  $R_2$  has to be adjusted to calibrate the instrument. During transistor on time  $t_{on}$  switches S2 and S3 act in parallel reducing the effective switch resistance by a factor of 2. The switch resistance can also be reduced by operating the circuit at a higher voltage, say 10V or more [5].

## A.2 Inductance meter

The half wave transistor rectifier configuration can be used to build a L-R based inductance meter as shown in Figure 5 right. It is basically a modification of the half wave rectifier which includes appropriate electronic switching to drive the L-R circuit to a certain current and then allow it to decay unhindered through the transistor rectifier, however simultaneously measuring the current in the collector circuit. The transistor has the property of transferring a current from a lower resistance circuit (base-emitter) into a higher resistance circuit (base-collector). This property has been exploited here to measure inductance. By using a series L-R circuit in the emitter in place of the a.c. voltage source it is possible to let a current carrying L-R circuit decay completely. At the same time this current can be measured without hindering the decay process in the L-R circuit. This is sufficiently warranted by the property of the transistor, for which it also derives its name! Transient analysis (Figure 6) of L-R circuit shows that, if in a certain time  $t_{off}$  the L-R circuit's current reduces to sufficiently low value say 5% or even less then for a period  $t_{off}$  the average current is directly proportional to the value of the inductance. This is justified as, higher the value of inductance higher is the energy stored ( $=0.5LI^2$ ), for a given current. We can as well include another constant  $t_{on}$  with  $t_{off}$  without any loss of proportionality. During  $t_{on}$  (transistor on time) the inductor is driven to a maximum current  $i_0 \sim (V_S - 0.6)/R$  using proper switching circuitry. The plan to measure inductance is to first drive the L-R circuit to a maximum current  $i_0$  during the time  $t_{on}$ . For the period  $t_{on}$  the current through the meter is cutoff using the switch S4. Switch S3 opens to the +ve of the supply, S2 biases the transistor by connecting to +ve of the supply and S1 is off. The current through the L-R circuit evolves as a standard L-R circuit connected to a source of voltage  $V_S - 0.6$  and at the end of  $t_{on}$  would have almost reached the maximum allowed current through the resistor R, i.e.  $i_0$ . These waveforms have been shown in detail in Figure 6. The periods  $t_{on}$  &  $t_{off}$  (transistor rectifier time) should be kept as close as possible (i.e. equal). During  $t_{off}$  the switches S2 and S3 are off and S1 and S4 are on. The current in the inductor now decays through the half wave rectifier. Since the transistor half wave rectifier is near to an ideal rectifier the decay loop appears essentially as an unhindered closed path to the L-R circuit. A tiny portion of the L-R current flows through the base but does not affect the inductance measurement seriously due to its negligible magnitude. Majority of the emitter current flows to the collector through the meter. As has been shown in the following discussion the average value of this is proportional to the inductance L. At the end of  $t_{off}$  the current through the

inductor would have decayed to almost zero value. The end result of the analysis of the inductance meter is contained in the following equation.

$$L_{actual} = L_{read} \left( \frac{2.5 + R_{coil}}{2.5} \right)^2 \quad (1)$$

Where  $R_{coil}$  (in  $k\Omega$ ) is the coil resistance of the inductor  $L_X$  under measurement. This has to be measured using a resistance meter and is seriously applicable if  $L_X$  has appreciable coil-resistance.  $L_{read}$  is the value indicated by the inductance meter. The following discussion considers  $t_{on}$  and  $t_{off}$  phases and quantifies various transients and derives the above equation.

First the evolution of charging current through the L-R circuit is considered. The magnitude of current at a time  $t$  in the L-R circuit when a potential difference exists across it is,

$$i = i_0 \left( 1 - e^{-\frac{R}{L_X}t} \right) \quad (2)$$

where  $i_0 (\sim (V_S - 0.6)/R)$  is the maximum current achieved at time  $t = \infty$ . By considering the values of the components associated with NE555 we see that  $t_{on} \sim 20\mu s$  when set for measuring a maximum inductance of 5mH. For this setting the maximum value of  $R/L$  that is possible is  $2500/0.005 = 500000$ . So we see that at  $t = t_{on}$  the exponential term in (1) is almost 0 as  $(Rt_{on}/L_X) = 10$ . This means  $i = i_0$  at  $t = t_{on}$ .

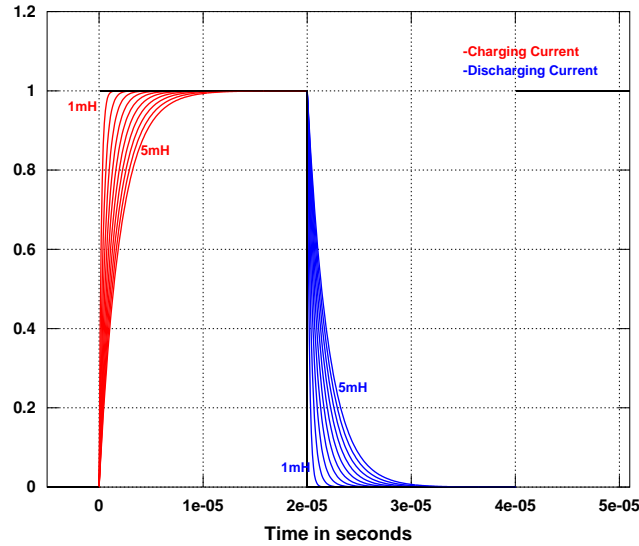

Figure 6: Plot of fractional current Vs time for different values of inductor charged through a resistor of 2.5k $\Omega$ . Here decaying current has been called discharging current.

Next we consider the decay or discharge of current during  $t_{off}$ . The current at time  $t$  in the L-R circuit once it starts decay is given by,

$$i = i_0 e^{-\frac{R}{L_X}t} \quad (3)$$

Since  $t_{off} \sim t_{on}$  we see from the previous argument that  $i = 0$  at  $t = t_{off}$ . The plots of evolution/decay of currents in the L-R circuit have been shown in Figure 6.

The timing diagram(Figure 6) clearly indicates that the current at the end of  $t_{on}$  would have reached the maximum value or it would have decayed to 0 at the end of  $t_{off}$ . So the average current through the meter assuming that the emitter current almost flows to the collector can be calculated as,

$$i_{avg} = \frac{i_0}{t_{on} + t_{off}} \int_0^{t_{off}} e^{-\frac{R}{L_X}t} dt \quad (4)$$

$$i_{avg} = \frac{i_0 L_X}{R(t_{on} + t_{off})} \quad (5)$$

We see that the average current is directly proportional to the value of the inductance  $L_X$ . Since  $t_{on} \sim t_{off}$  by the choice of  $R_1$  and  $R_2$  for NE555 astable [6], to measure values of inductances over a wide range it is sufficient to change the timing capacitor associated with NE555 as this would proportionally increase  $(t_{on} + t_{off})$  leaving  $i_{avg}$  unaltered. To double the range of inductance measurement the value of this capacitor has to be simply doubled. Figure 5 shows the switching arrangement that changes the range in steps of decades.

The inductor will also have an associated resistance with it which depends on the length/thickness of the wire. This can be accounted by modifying (4) as,

$$i_{avg} = \frac{(i_0 R / (R + R_{Lx})) L_X}{R(R + R_{Lx})(t_{on} + t_{off})} R \quad (6)$$

$$i_{avg} = \frac{i_0 L_X}{R(t_{on} + t_{off})} \left( \frac{R}{R + R_{Lx}} \right)^2 \quad (7)$$

which is essentially multiplying the actual inductance by the factor  $(R/(R+R_{Lx}))^2$ . The manipulation in (5) is that due to the introduction of extra resistance  $R_{Lx}$  with  $L_X$  the peak current to which the inductor is driven has reduced from  $i_0$  to  $i_0 R/(R+R_{Lx})$ . Next in the denominator  $R$  has to be replaced by  $(R+R_{Lx})$ . To rewrite and retain the form of (5) we throw an extra  $R$  in the numerator and denominator and rearrange into (6).  $R_{Lx}$  can be measured separately using a resistance meter.  $R$  is known to be  $2.5k\Omega$  as per this design. It should be noted that  $R$  can be changed to  $5k\Omega$  resulting in the modified range of 0-10mH instead of 0-5mH. The current evolution plots would still be the same with 5mH curve indicating the one for 10mH, but the peak current  $i_0$  would be halved. Further  $R$  may have to be calibrated slightly to get the right value of inductance. The actual inductance is obtained as the observed inductance multiplied by the inverse of the above mentioned factor i.e,  $((R+R_{Lx})/R)^2$ . For example if  $R=2.5k\Omega$  as in our case we have,

$$L_{actual} = L_{read} \left( \frac{2.5 + R_{Lx}}{2.5} \right)^2 \quad (8)$$

where  $R_{Lx}$  is in  $k\Omega$ .  $L_{actual}$  is the true inductance of the test inductor and  $L_{read}$  is that shown by the meter. Figure 7 shows a circuit layout to help the reader build the instrument. Actual performance of the instrument can be seen at <http://youtu.be/Vyd84HvYhyo> and <http://youtu.be/E7cgomOn5pQ>

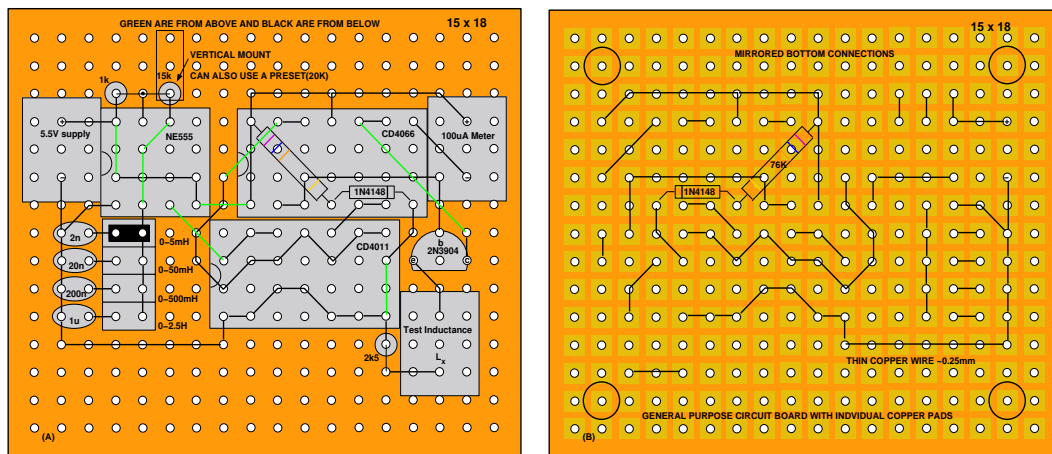

Figure 7: Circuit layout for the Inductance Meter.

## References

- [1] Baddi R., Use a transistor and an ammeter to measure inductance, Design Ideas, EDN, April 05, 2012 .
- [2] [http://en.wikipedia.org/wiki/Schottky\\_diode](http://en.wikipedia.org/wiki/Schottky_diode)
- [3] Kasatkin A.S., Nemtsov M.V., Electrical Engineering, Mir Publishers, pp 260(5).
- [4] Pookaiyaudom S., Watanachaiprateep C. And Dejhan K., A Single Transistor Full-Wave Rectifier., 1979, Vol 67, Proceedings of the IEEE.

[5] [www.ti.com/product/cd4066b?CMP=AFC-conv\\_SF\\_SEP](http://www.ti.com/product/cd4066b?CMP=AFC-conv_SF_SEP).

[6] [www.ti.com/product/ne555b?CMP=AFC-conv\\_SF\\_SEP](http://www.ti.com/product/ne555b?CMP=AFC-conv_SF_SEP) or [www.datasheetarchive.com](http://www.datasheetarchive.com).