

Spin Transfer Torques induced by Spin Hall Effect

A. Vedyayev,^{1,2} N. Strelkov,^{1,2} M. Chshiev,¹ N. Ryzhanova,^{1,2} and B. Dieny¹

¹SPINTEC, UMR 8191 CEA-INAC/CNRS/UJF-Grenoble 1/Grenoble-INP, 38054 Grenoble, France

²Department of Physics, Moscow Lomonosov State University, Moscow 119991, Russia

Spin accumulation and spin transfer torques induced by Spin Hall Effect in bi-layer structures comprising ferromagnetic and paramagnetic materials are theoretically investigated. The charge and spin diffusion equations taking into account spin-flip and spin Hall effect are formulated and solved analytically and numerically for in structures with simplified and complex geometry, respectively. It is demonstrated that spin torques could be efficiently produced by means of Spin Hall effect which may be further enhanced by modifying structure geometry.

INTRODUCTION

In [1, 2] Dyakonov and Perel predicted the existence of Spin Hall Effect (SHE) in paramagnetic metal without applying the external magnetic field under influence of spin-orbit interaction. It was found later a lot of similarities between the “anomalous” Hall Effect in ferromagnetic metals (FM) and SHE [3, 4], assuming that in both cases the mechanisms of creation of the transversal electric current is the skew scattering or side jump mechanism due to the spin-orbit interaction. The more detailed analyses of SHE was presented in [5–7] employing the semi-classical Boltzmann equation in [5] and Keldish formalism in [6, 7] for the calculation of the transport properties of the paramagnetic metal taking into account the spin-orbit interaction. It is considered that SHE may be very effective tool for the manipulation with spin current and spin accumulation. The most interesting could be the hybrid structure consisting of ferromagnetic (FM) metal/paramagnetic (PM) metal with large SHE, if both mechanisms of creation of the spin current are involved: SHE and spin polarization by ferromagnetic metal. In this work we investigate spin transfer torques produced by the interplay between these mechanisms in FM/NM bi-layer structures by solving charge and spin diffusion equations.

MODEL

For the calculation both spin accumulation and spin polarized current in such a structure which may have a complex geometry, it is necessary to derive spin diffusion equation taking into account both SHE for the paramagnetic metal and processes governing the spin transport in ferromagnetic metal. It is necessary also to develop the convenient code for the numerical simulations for the system of the complicated geometry in 2D and 3D cases. Following [8–11] where the diffusion equation describing spin transport in ferromagnetic multilayered structures were developed and with diffusion equation obtained in [7] and describing SHE we can write down:

$$\vec{j}_e = -\sigma_0 \vec{\nabla} \varphi - \beta \frac{\sigma_0}{e\nu} \vec{\nabla} (\vec{U}_M, \vec{m}) + a_0^3 \sigma_{SH} [\vec{m} \times \vec{\nabla} \varphi] \quad (1)$$

$$\vec{j}_m^{(i)} = -\beta \sigma_0 \vec{\nabla} \varphi U_M^{(i)} - \frac{\sigma_0}{e\nu} \vec{\nabla} m^{(i)} - \sigma_{SH} U_m^{(i)} [\vec{U}_m \times \vec{\nabla} \varphi] \quad (2)$$

$$\begin{cases} \operatorname{div} \vec{j}_e = 0 \\ \operatorname{div} \vec{j}_m^{(i)} = -\frac{\sigma_0}{e^2 \nu l_J^2} [\vec{m} \times \vec{U}_M]^{(i)} - \frac{\sigma_0}{e^2 \nu l_{sf}^2} m^{(i)}, \end{cases} \quad (3)$$

where σ_0 is the conductivity, β is the spin-asymmetry parameter of conductivity, σ_{SH} is the spin Hall conductivity, ν – density of states, $\vec{U}_M = \vec{M}/M_s$, where \vec{M} is magnetization vector in ferromagnetic, $\vec{U}_M = \vec{m}/|\vec{m}|$, where \vec{m} is spin accumulation vector, index i is a component of vectors \vec{m} , \vec{j}_m and \vec{U}_M in spin space, l_{sf} – spin diffusion length and l_J – exchange spin diffusion length. Inside the ferromagnetic metal one have to omit the terms of SH, and in paramagnetic metal $\beta = 0$. In equation (1) we added the last term, which is quadratic on the $\vec{\nabla} \varphi$ as the value of m is proportional to $\vec{\nabla} \varphi$, and in (2) we omitted terms corresponding to the contribution of the anomalous velocity (see (2))

in [7]). Here we have to mention the article [12], where it was proven that the large $\sigma_{\text{SH}}/\sigma_0$, experimentally observed for *Au* doped by *Fe* and *Pt* impurities [13, 14] and for *Cu* doped by *Ir* [15] may be attributed to the resonant electron scattering on impurities if take into account spin-orbit interaction.

Let us consider the system, consisting of two flat layers, one of the paramagnetic metal with SHE and second ferromagnetic layer with current in x direction. If to consider the case $L_x > L_y \gg L_z^F + L_z^P$, where L_x and $L_z^F + L_z^P$ are the lengths of the system in x and z directions, the solution of (3) in the region of x far from $(-L_x, L_x)$ may be easily found, and expression for φ , $m^{(2)}$ ($m^{(0)} = m^{(3)} = 0$) are the following:

$$m^{(1)} = -V \frac{e\nu}{D} \frac{\sigma_{\text{SH}}}{\sigma_1} \frac{l_{\text{sf},1}}{L_x} \left[\sinh \frac{L_1}{2l_{\text{sf},1}} \sinh \frac{L_1 + 2z}{2l_{\text{sf},1}} + \frac{\sigma_2}{\sigma_1} \frac{l_{\text{sf},1}}{l_{\text{sf},2}} (1 - \beta^2) \tanh \frac{L_2}{l_{\text{sf},2}} \sinh \frac{z}{l_{\text{sf},2}} \right] \quad (4)$$

$$m^{(2)} = -V \frac{e\nu}{D} \frac{\sigma_{\text{SH}}}{\sigma_1} \frac{l_{\text{sf},1}}{L_x} \sinh^2 \frac{L_1}{2l_{\text{sf},1}} \cosh \frac{L_2 - z}{l_{\text{sf},2}} / \cosh \frac{L_2}{l_{\text{sf},2}} \quad (5)$$

$$\begin{aligned} \varphi_1 = & \frac{V}{2} \left(1 + \frac{x}{L_x} \right) - V^2 \frac{(e\nu)^2}{2D} \left(\frac{\sigma_{\text{SH}}}{\sigma_1} \frac{l_{\text{sf},1}}{L_x} \right)^2 \sinh^2 \frac{L_1}{2l_{\text{sf},1}} \\ & \times \left[2 \sinh \frac{L_1}{2l_{\text{sf},1}} \cosh \frac{L_1 + 2z}{2l_{\text{sf},1}} + \frac{\sigma_2}{\sigma_1} \frac{l_{\text{sf},1}}{l_{\text{sf},2}} \frac{\cosh \frac{z}{l_{\text{sf},2}} - \cosh \frac{L_x}{l_{\text{sf},1}}}{1 - \cosh \frac{L_x}{l_{\text{sf},1}}} \tanh \frac{L_2}{l_{\text{sf},2}} \right] \end{aligned} \quad (6)$$

$$\begin{aligned} \varphi_2 = & \frac{V}{2} \left(1 + \frac{x}{L_x} \right) - V^2 \frac{(e\nu)^2}{2D} \left(\frac{\sigma_{\text{SH}}}{\sigma_1} \frac{l_{\text{sf},1}}{L_x} \right)^2 \sinh^2 \frac{L_1}{2l_{\text{sf},1}} \\ & \times \left[\sinh \frac{L_1}{l_{\text{sf},1}} + \frac{\sigma_2}{\sigma_1} \frac{l_{\text{sf},1}}{l_{\text{sf},2}} \tanh \frac{L_2}{l_{\text{sf},2}} \right] - V \left[\text{sign } U_M^{(2)} \right] \frac{\beta}{D} \frac{\sigma_{\text{SH}}}{\sigma_1} \frac{l_{\text{sf},1}}{L_x} \frac{\cosh \frac{L_2}{l_{\text{sf},2}} - \cosh \frac{L_2 - z}{l_{\text{sf},2}}}{\cosh \frac{L_2}{l_{\text{sf},2}}} \end{aligned} \quad (7)$$

$$D = \sinh \frac{L_1}{l_{\text{sf},1}} + \frac{\sigma_2}{\sigma_1} \frac{l_{\text{sf},1}}{l_{\text{sf},2}} (1 - \beta^2) \tanh \frac{L_2}{l_{\text{sf},2}} \cosh \frac{L_1}{l_{\text{sf},1}},$$

where L_1 and L_2 – are thicknesses of SH-layer and FM-layer respectively.

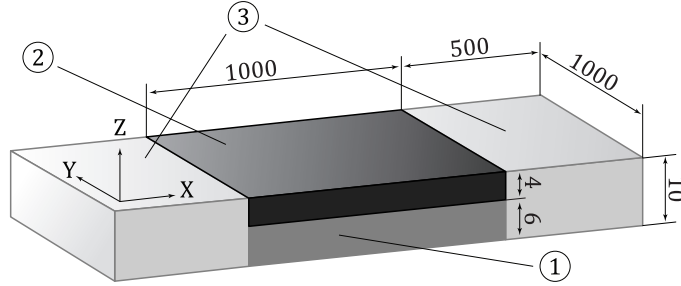

FIG. 1: Schematic of *Pt*/*Py* bylayer. Sizes are in “nm”. 1 – *Pt* layer, 2 – *Py* layer, 3 – *Cu* electrodes. Current is along x axe. Magnetisation of *Py* is in xy plane at $\pi/4$ angle to x axe.

The spin accumulation $m^{(2)}$ produces the effective field H_{eff} acting on the magnetisation of the ferromagnetic layer, which value is equal $H_{\text{eff}} = m^{(2)} J_{sd} / \mu_B$, where J_{sd} is s - d exchange integral. It is important to notice that this field is proportional to drop of voltage and not to current density, as in the case of Oersted field created by the current. So if one choose as a source of SHE dirty paramagnetic metal only due to its higher resistance the value of the induced by SHE effective field for the constant current density will increase, and besides that the following conclusion of [12] the value of $\sigma_{\text{SH}}/\sigma_0$ may increase as well. Another interesting conclusion, following from expression for the potential φ , is that SHE produce drop of voltage in z direction perpendicular to the current. If there is no ferromagnetic layer above SHE structure the drop of voltage is symmetric ($\propto \cosh[z/l_{\text{sf}}]$) and quadratic on the applied voltage V , but in presence of FM layer this drop has linear on V part and is finite across the thickness of the system. To investigate the influence of the edge of layers on spin accumulation in the system of finite size we have solved equation of (3) numerically using Comsol Multiphysics for several artificial system, consisting of SHE substrate and ferromagnetic layers or dots situated on the top of this substrate.

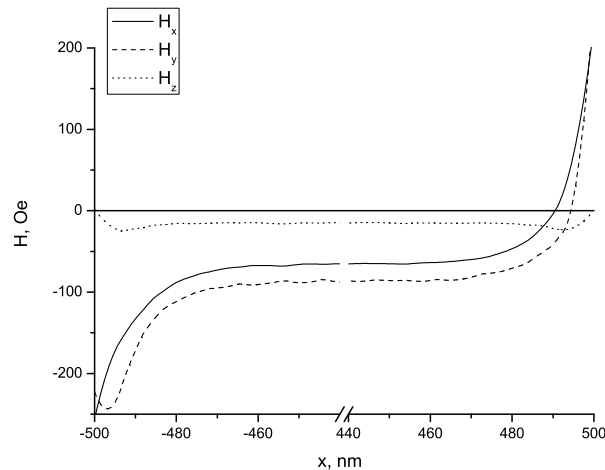

FIG. 2: Effective fields induced by *Pt* SHE in *Pt* near the interface. Adopted values of the parameters: $\sigma^{Pt} = 0.005(\Omega \cdot \text{nm})^{-1}$, $l_{\text{sf}}^{Pt} = 10 \text{ nm}$, $\sigma_{\text{SH}}^{Pt} = 0.1\sigma^{Pt}$, $\sigma^{Py} = 0.0022(\Omega \cdot \text{nm})^{-1}$, $l_{\text{sf}}^{Py} = 6 \text{ nm}$, $\beta = 0.7$, $l_J = 1 \text{ nm}$, current density $j = 10^7 \text{ A/cm}^2$.

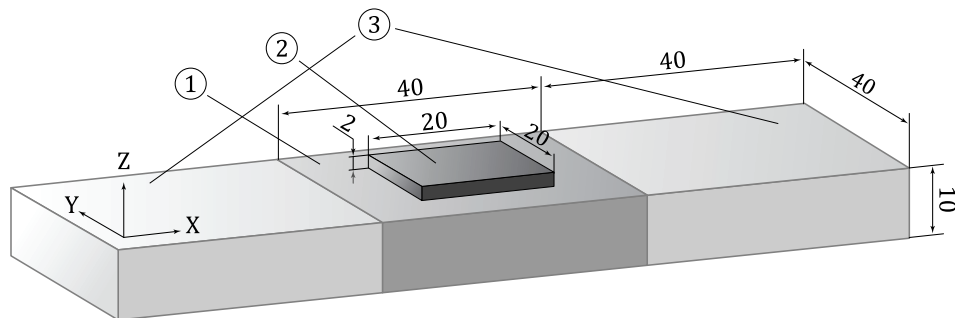

FIG. 3: Schematic of *Pt/Py* bilayer. Sizes are in “nm”. 1 – *Pt* layer, 2 – *Py* layer, 3 – *Cu* electrodes. Current is along *x* axis. Magnetisation of *Py* is in *xy* plane at $\pi/4$ angle to *x* axis or along *z* axis.

RESULTS

In Fig.1 we give the schematic of *Pt/Py* bilayer, which was experimentally investigated in [16]. In fig.2 the dependence on *x* coordinate of the induced by SHE fields H_{SHE} acting on the magnetization inside of *Py* layer and near the *Pt/Py* interface is shown. It is clear that SHE spin current produce all three components of the field, meanwhile Oersted field H_j produced by the current in given geometry has only *y*-component, and $H_j = 4 \text{ Oe}$. The *z*-component of the SHE field produces torque in the plane of the *Py* layer, and the ratio H_{SHE}/H_j lies within the interval $1.3 \div 3.7$, where 1.3 is the average value over the volume of *Py* layer while 3.7 represents this ratio near the interface, what is close to the value recalculated using value of $S/A = 0.63$ in [16] which gives $H_{\text{SHE}}/H_j = \sqrt{1 + 4\pi M_{\text{eff}}/H_{\text{eff}}} S/A = 1.9$ in notations of [16].

To investigate the possibility to manipulate with magnetization of small ferromagnetic dots under influence of SHE current we have calculated the field induced by SHE in the small ferromagnetic dot situated on the surface of paramagnetic metallic layer with SHE as shown in Fig. 3. The direction of magnetization of the ferromagnetic dot forms the angle $\pi/4$ with *x*-axes, or it is parallel or antiparallel to *y* axes. In the case $\vec{M} \parallel y$ only *y*-component of induced fields not zero and its average value does not change under inversion of magnetization direction along *y* axes. This field is much stronger than Oersted field which is about 5 Oe. Besides that field does not produce any torque but defines the most energetically favorable direction of magnetization. When this direction is not collinear with *y*-axes, the SHE produces not only *y*-component of spin accumulation but all three *xyz* components of spin accumulation due to the precession of spin accumulation vector in exchange field of ferromagnet.

In fig.5 the dependence on *x* coordinate of three components of spin transfer torque, produced by spin accumulation

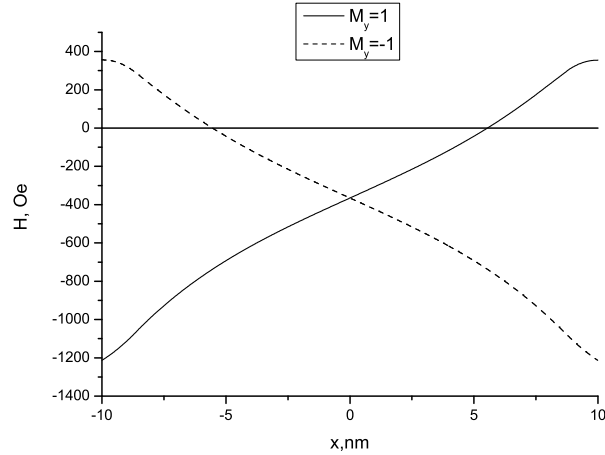

FIG. 4: Effective fields in Co/Pt structure for the direction of magnetisation parallel and antiparallel to y axis. Only H_y component survive. $\sigma^{Co} = 0.005(\Omega \cdot nm)^{-1}$, $l_{sf}^{Co} = 10nm$.

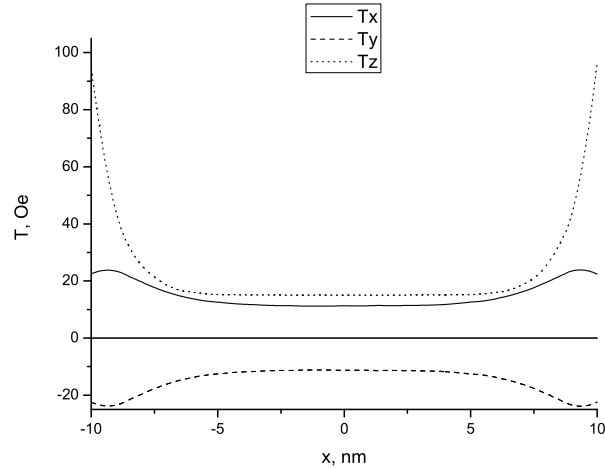

FIG. 5: Effective torques for the case of $\vec{U}_M = (\cos \pi/4; \sin \pi/4; 0)$ near the interface. Averaged values over volume of Co are $\langle T_x \rangle = 15 Oe$, $\langle T_y \rangle = -15 Oe$, $\langle T_z \rangle = 3 Oe$.

due to the SHE are shown. The torque acting on magnetisation is defined as $[\vec{M} \times \vec{H}_{SHE}]$, and in LLG equation it has to be multiplied by the gyromagnetic ratio γ . For the case $U_m = (\cos \pi/4; \sin \pi/4; 0)$ the xy part of torque vector $\vec{T} = (T_x; T_y; 0)$ is lying in xy plane perpendicular to \vec{U}_m and may be considered like an additional damping or antidamping term in LLG equation. The torque due to Oersted field has only z -component.

For the case of $\vec{M} \parallel Oz$, T_x and T_y torque components value close to the interface are shown in fig.6. These torques try to reorient magnetization of FM layer onto xy plane and T_y component may be considered like damping or antidamping term. We checked the results taking the spin Hall conductivity equal to zero and obtained that all torques besides one produced by Oersted field of the current vanish.

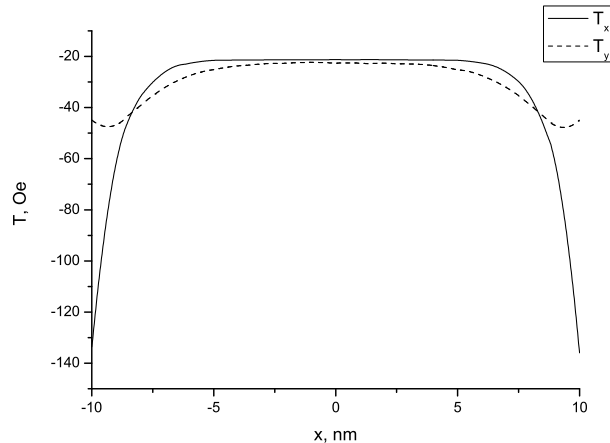

FIG. 6: Effective torques near the interface in case of $M \parallel Oz$. Averaged values over volume of *Co* are $\langle T_x \rangle = -4 Oe$, $\langle T_y \rangle = -30 Oe$.

CONCLUSIONS

We have shown that SHE may represent a powerful tool for the manipulation with magnetization of small ferromagnetic metal dots situated on the surface of the thin paramagnetic metal layer with large value of SHE conductivity. Especially important feature of spin transfer torques created by spin accumulation due to influence of SHE is that these torques have component similar to damping or antidamping spin torque produced by current in non-collinear magnetic multilayers.

ACKNOWLEDGMENTS

This work has been supported by Russian Fund of Fundamental Research, ERC Advanced Grant "HYMAGINE" and by French National Research Agency Project ANR-10-BLANC "SPINHALL".

-
- [1] M. I. D'yakonov and V. I. Perel', JETP **13**, 467 (1971).
 - [2] M. I. Dyakonov and V. I. Perel, Phys. Lett. A **35**, 459 (1971).
 - [3] A. Fert, A. Friederich, and A. Hamzic, Journal of Magnetism and Magnetic Materials **24**, 231 (1981).
 - [4] J. E. Hirsch, Phys. Rev. Lett. **83**, 1834 (1999).
 - [5] S. Zhang, Phys. Rev. Lett. **85**, 393 (2000).
 - [6] R. V. Shchelushkin and A. Brataas, Phys. Rev. B **71**, 045123 (2005).
 - [7] R. V. Shchelushkin and A. Brataas, Phys. Rev. B **72**, 073110 (2005).
 - [8] T. Valet and A. Fert, Phys. Rev. B **48**, 7099 (1993).
 - [9] S. Zhang, P. M. Levy, and A. Fert, Phys. Rev. Lett. **88**, 236601 (2002).
 - [10] N. Strelkov, A. Vedyayev, D. Gusakova, L. D. Buda-Prejbeanu, M. Chshiev, S. Amara, A. Vaysset, and B. Dieny, Magnetics Letters, IEEE **1**, 3000304 (2010).
 - [11] N. Strelkov, A. Vedyayev, N. Ryzhanova, D. Gusakova, L. D. Buda-Prejbeanu, M. Chshiev, S. Amara, N. de Mestier, C. Baraduc, and B. Dieny, Phys. Rev. B **84**, 024416 (2011).
 - [12] A. Fert and P. M. Levy, Phys. Rev. Lett. **106**, 157208 (2011).
 - [13] S. Takeshi, H. Yu, M. Seiji, T. Saburo, I. Hiroshi, M. Sadamichi, N. Junsaku, and K. Takanashi, Nature Materials **7**, 125 (2008).
 - [14] S. Takeshi, private communication.
 - [15] Y. Niimi, M. Morota, D. H. Wei, C. Deranlot, M. Basletic, A. Hamzic, A. Fert, and Y. Otani, Phys. Rev. Lett. **106**, 126601 (2011).
 - [16] L. Liu, T. Moriyama, D. C. Ralph, and R. A. Buhrman, Phys. Rev. Lett. **106**, 036601 (2011).