

Gaussification and Entanglement Distillation of Continuous-Variable Systems: A Unifying Picture

Earl T. Campbell and Jens Eisert

*Dahlem Center for Complex Quantum Systems, Freie Universität Berlin, 14195 Berlin, Germany and
Institute of Physics and Astronomy, University of Potsdam, 14476 Potsdam, Germany*

Distillation of entanglement using only Gaussian operations is an important primitive in quantum communication, quantum repeater architectures, and distributed quantum computing. Existing distillation protocols for continuous degrees of freedom are only known to converge to a Gaussian state when measurements yield precisely the vacuum outcome. In sharp contrast, non-Gaussian states can be deterministically converted into Gaussian states while preserving their second moments, albeit by usually reducing their degree of entanglement. In this work – based on a novel instance of a non-commutative central limit theorem – we introduce a picture general enough to encompass the known protocols leading to Gaussian states, and new classes of protocols including multipartite distillation. This gives the experimental option of balancing the merits of success probability against entanglement produced.

PACS numbers: 03.67.Bg, 42.50.Ex

Entangled quantum states are the fundamental resources that enable quantum key distribution, quantum communication, and instances of distributed quantum computing. Real physical systems are affected by decoherence and non-ideal apparatus that degrades the quality of experimentally preparable quantum states. However, entanglement distillation protocols provide a means of converting many copies of partially entangled states into a smaller number of more entangled states [1]. When entanglement is required over very long distances, distillation can be implemented at regular intervals called repeater nodes [2–4]. Photonic systems that carry entanglement in continuous degrees of freedom are difficult to manipulate arbitrarily. However, so-called *Gaussian* operations are more easily implemented by a combination of beam splitters, phase shifters and squeezers. Furthermore, preparation of Gaussian states is routine in many laboratories, and such states are especially useful for numerous quantum information tasks.

Unfortunately, Gaussian operations are quite limited in their capacity to distill entanglement. In particular, a series of no-go theorems have shown that with only Gaussian resources, it is impossible to increase entanglement [5]. These results can be circumvented when non-Gaussian resources are available. Given an appropriate resource, Gaussian operations can simultaneously increase the entanglement and make the state more Gaussian, a process we refer to as the “*Gaussification protocol*” (GP) [6] (for steps towards experimental realization of this and related protocols, see Refs. [7]). Alternatively, the theorem can also be circumvented by using a non-Gaussian operation implemented by photon detectors. Entanglement distillation can be achieved by a combination of photon subtraction, a de-Gaussifying operation, and Gaussification [6, 8].

While these techniques give hope for simple realizations of quantum information protocols, they do not exploit the richness of Gaussian operations. Specifically, GP utilizes only projections onto the vacuum. These projections are feasible if reliable detectors are available that distinguish zero from one or more photons. However, strictly speaking these detectors do not fall within the realm of Gaussian devices. Per-

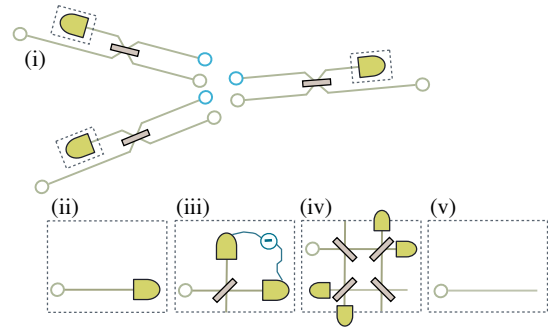

FIG. 1: (i) A single step of the general class of protocols (GG) considered, illustrated for three parties. This embodies the known Gaussifier (GP) entanglement distillation schemes based on projections onto the vacuum, or the extremality protocol (EP) mapping unknown states onto Gaussian ones with the same second moments. The Gaussian projection can be arbitrary (including (ii) vacuum projection, (iii) homodyning, (iv) eight-port homodyning, (v) tracing out); and schemes with finite widths of acceptance.

forming eight-port homodyne detection [9] and postselecting on the vacuum outcome achieves the same projection, but this will have zero success probability when postselecting *exactly* on the vacuum measurement outcomes. In this work, we prove Gaussification for a wide class of truly Gaussian protocols with nonzero, and tunable, success probabilities for multimode states. All known feasible distillation protocols, including our protocols, are iterative and consume a number of copies exponential in the iterations required. As such, our scheme’s capability to increase success probability significantly improves the prospects of distillation and repeater implementations with only modest resources. Our techniques also open up the perspective of directly distilling into multipartite Gaussian states.

In addition to the practical applications of our results, our analysis provides a more intuitive explanation of the phenomena of Gaussification. In the original distillation protocols [6], the process of Gaussification is quite mysterious, but it is very apparent in the protocol of Ref. [10] which provides an al-

ternative method that uses no measurements, referred to as the “*extremality protocol*” (EP), as it is used to show the extremality of Gaussian states with respect to several properties. Yet EP can convert many non-Gaussian states into a more Gaussian state while conserving the expectation value of observables quadratic in position and momentum. Although the EP does Gaussify, its capacity for increasing entanglement is restrained by its deterministic nature. The proof of EP elegantly employs the central limit theorem [11] that explains the ubiquity of Gaussian distributions in classical statistics and nature itself. Our approach unifies GP and EP within a comprehensive theory of “*general Gaussification*” (GG) founded on a non-commutative central limit theorem and so provides an intuitive mechanism for Gaussification. In addition to bipartite entanglement distillation, our approach reveals whole new classes of protocols that we discuss.

We consider GG protocols that can be implemented iteratively, with the $(n + 1)^{\text{th}}$ iteration as follows:

1. Take two copies of an m -mode state ρ_n shared between m parties;
2. Each party applies a 50:50 beam-splitter transformation between their pair of modes;
3. Every party makes a Gaussian measurement on the output of one beam-splitter port;
4. The parties compare measurement results and postselect such that the operation implemented is Gaussian;
5. The output state ρ_{n+1} is used for the next iteration.

Formal description of GG protocols. There are $2m$ modes involved in the protocol, and we label annihilation operators, $\hat{a}_{j,k}$, with two indices; The index $j = 1, 2, \dots, m$ labels the respective party and $k = 1, 2$ the copy at a particular node. The beam-splitters, in the Heisenberg picture, perform

$$U\hat{a}_{j,k}U^\dagger = (\hat{a}_{j,1} + (-1)^k\hat{a}_{j,2})/\sqrt{2}. \quad (1)$$

The measurements at step 3 can be homodyne, eight-port homodyne, or any other Gaussian measurements projecting onto a state $\Pi_{\mathbf{m}}$ for measurement outcome \mathbf{m} . We are interested in Gaussian protocols that postselect on a set of measurement outcomes, and mix over all accepting outcomes,

$$\rho_{n+1} \propto \int d\mathbf{m} P(\mathbf{m}) \text{tr}^2[U(\rho_n \otimes \rho_n)U^\dagger(\mathbb{1} \otimes \Pi_{\mathbf{m}})] \quad (2)$$

where tr^2 denotes a partial trace over the second copy, with $k = 2$. The integral over measurement outcomes is weighted by $P(\mathbf{m})$. The weights $P(\mathbf{m}) = 0$ and $P(\mathbf{m}) = 1$ correspond to a rejection and an acceptance, respectively, but we also allow for probabilistic strategies where $P(\mathbf{m})$ gives the probability of acceptance. The protocol is described by a single operator we call the *filter*

$$\Pi = \int d\mathbf{m} P(\mathbf{m}) \Pi_{\mathbf{m}}. \quad (3)$$

We allow for arbitrary Gaussian filters, Π , that are invertible and proportional to a fully separable Gaussian state with vanishing first moments and finite energy. Certain interesting

cases, such as GP, EP and protocols using precise homodyne detection are included as limits within this family of filters, so keeping full generality. With this notation

$$\rho_{n+1} \propto \text{tr}^2[U(\rho_n \otimes \rho_n)U^\dagger(\mathbb{1} \otimes \Pi)]. \quad (4)$$

Phase space. Before we give our results, we review phase space representations for the position and momentum observables of an m -mode system, labeled as

$$\hat{\mathbf{R}} = (\hat{R}_1, \hat{R}_2, \dots, \hat{R}_{2m-1}, \hat{R}_{2m}) = (\hat{X}_1, \hat{P}_1, \dots, \hat{X}_m, \hat{P}_m),$$

where $\hat{X}_j = (\hat{a}_j^\dagger + \hat{a}_j)/\sqrt{2}$ and $\hat{P}_j = i(\hat{a}_j^\dagger - \hat{a}_j)/\sqrt{2}$ for $j = 1, \dots, m$. The canonical commutation relations between the coordinates are embodied in the symplectic matrix Σ . The *covariance matrix* of an operator A records the second moments of these observables.

$$(\Gamma_A)_{j,k} = \text{tr}(\{\hat{R}_j - (\mathbf{d}_A)_j, \hat{R}_k - (\mathbf{d}_A)_k\}_+ A), \quad (5)$$

where $\{\cdot, \cdot\}_+$ denotes the anticommutator and first moments are $(\mathbf{d}_A)_j = \text{tr}(\hat{R}_j A)$. Furthermore, we make use of characteristic functions, $\chi_A : \mathbb{R}^{2m} \rightarrow \mathbb{C}$, that encode all the information of A as $\chi_A(\mathbf{r}) = \text{tr}(D(\mathbf{r})A)$, where $D(\mathbf{r})$ is the displacement operator, $D(\mathbf{r}) = \exp(i\mathbf{r} \cdot \hat{\mathbf{R}})$. Such a function is said to be Gaussian when

$$\chi_A(\mathbf{r}) = \exp(i\mathbf{r} \cdot \mathbf{d}_A - \mathbf{r}^T \Gamma_A \mathbf{r}/4). \quad (6)$$

If the operator A is a physical state, its covariance matrix will be real. However, an instrumental tool in our analysis is that we work with $A = \sigma_n = \rho_n \Pi / \text{tr}(\rho_n \Pi)$. Indeed, we will not employ characteristic functions of states satisfying the conditions of Bochner’s theorem [11, 12], but of more general objects, hence leading to more general complex-valued functions. Since Π is invertible, σ_n uniquely defines a quantum state ρ_n .

A new non-commutative quantum central limit theorem. With these definitions at hand we can state our first result, with a stronger form of convergence demonstrated later.

Theorem 1 (Convergence of general Gaussifier protocols)
Consider an initial state $\rho = \rho_0$, with associated operator $\sigma = \rho \Pi / \text{tr}(\rho \Pi)$ such that the following conditions are satisfied: (i) $\mathbf{d}_\sigma = 0$; (ii) $|\chi_\sigma(\mathbf{r})| \leq 1$ for all \mathbf{r} ; (iii) the covariance matrix

$$\Gamma_{\rho_\infty} = (\Gamma_\Pi - i\Sigma)(\Gamma_\Pi - \Gamma_\sigma)^{-1}(\Gamma_\Pi + i\Sigma) - \Gamma_\Pi, \quad (7)$$

exists and is positive definite. Let ρ_∞ denote the Gaussian state with covariance matrix Γ_{ρ_∞} . GG with filter Π causes ρ_n to weakly converge to ρ_∞ in the following sense: If $|x\rangle$ and $|y\rangle$ are eigenvectors of Π , then for all $\epsilon > 0$ there exists a n_ϵ such that for all $n > n_\epsilon$

$$|\langle x | \rho_n | y \rangle / \text{tr}(\rho_n \Pi) - \langle x | \rho_\infty | y \rangle / \text{tr}(\rho_\infty \Pi)| < \epsilon. \quad (8)$$

Proof of the statement. Much of the basic structure of the proof follows an argument of a non-commutative quantum

central limit theorem for quantum states [10–13]. The problem once one allows for Gaussian measurements is that the characteristic function of the output is unwieldy indeed. We circumvent this problem by a bold step: We put in an additional filter Π at the output “by hand”, in order to exploit symmetry, at the expense of having to consider χ_{σ_n} of different objects, σ_n . This will then lead to the desired result. From Eq. (4) we have,

$$\chi_{\sigma_{n+1}}(\mathbf{r}) \propto \text{tr}[(D(\mathbf{r}) \otimes \mathbb{1})U(\rho_n \otimes \rho_n)U^\dagger(\Pi \otimes \Pi)]. \quad (9)$$

Using the cyclicity of the trace and Eq. (1)

$$\chi_{\sigma_{n+1}}(\mathbf{r}) \propto \text{tr}[D(\mathbf{r}/\sqrt{2})^{\otimes 2}\rho_n^{\otimes 2}U^\dagger\Pi^{\otimes 2}U]. \quad (10)$$

Next we recall that Gaussian states with zero first moments commute with beam-splitters, $U\Pi^{\otimes 2} = \Pi^{\otimes 2}U$, such that

$$\begin{aligned} \chi_{\sigma_{n+1}}(\mathbf{r}) &\propto \text{tr}\{[D(\mathbf{r}/\sqrt{2})\rho_n\Pi]^{\otimes 2}\} \propto \text{tr}[D(\mathbf{r}/\sqrt{2})\sigma_n]^2, \\ &= \chi_{\sigma_n}(\mathbf{r}/\sqrt{2})^2 = \chi_{\sigma}(\mathbf{r}/\sqrt{N})^N, \end{aligned} \quad (11)$$

where in the last equality $N = 2^{n+1}$, iterating the formula. The key to the simplicity of this formula is to consider convergence of σ_n rather than directly ρ_n . By introducing an additional projector within the trace, symmetry allows us to commute through the beam-splitter unitaries, which is the essential simplifying step. To find the limiting characteristic function, we consider a given phase space point \mathbf{r}_0 and the function $f_{\sigma_{n+1}, \mathbf{r}_0} : \mathbb{R} \rightarrow \mathbb{C}$ defined as $f_{\sigma_{n+1}, \mathbf{r}_0}(t) = \chi_{\sigma_{n+1}}(t\mathbf{r}_0)$. In the spirit of a *classical central limit theorem* [10, 11, 13] but for non-Hermitian operators we write

$$f_{\sigma, \mathbf{r}_0}\left(\frac{t}{\sqrt{N}}\right)^N \propto \left(1 - t^2 \frac{\mathbf{r}_0^T \Gamma_\sigma \mathbf{r}_0}{4N} + o\left(\frac{t^2}{N}\right)\right)^N, \quad (12)$$

which converges assuming that second moments are finite, $f(0) = 1$ and $|f(t)| \leq 1$ for all t . This last condition, which is always satisfied for classical characteristic functions, may be violated for non-Hermitian σ_n . However, provided $|\chi_\sigma(\mathbf{r})| \leq 1$ for all \mathbf{r} , we find (see App. A) in the limit of large n that

$$\lim_{n \rightarrow \infty} f_{\sigma_{n+1}}(t) \propto \exp(-t^2 \mathbf{r}_0^T \Gamma_\sigma \mathbf{r}_0 / 4), \quad (13)$$

pointwise in t . Setting $t = 1$ shows pointwise convergence of $\chi_{\sigma_{n+1}}$ for each phase space point \mathbf{r}_0 . Furthermore, following the reasoning of Refs. [12, 13], this entails that any operator B that is absolutely integrable such that $\int |\chi_B(\mathbf{r})| d\mathbf{r} < \infty$, has a convergent expectation value $\text{tr}(B\sigma_n) \rightarrow \text{tr}(B\sigma_\infty)$ (see App. B). Setting $B = \lambda_y^{-1}|y\rangle\langle x|$ where $\Pi|y\rangle = \lambda_y|y\rangle$, then for large n

$$\frac{\langle x|\rho_n|y\rangle}{\text{tr}(\rho_n\Pi)} = \frac{\langle x|\sigma_n|y\rangle}{\lambda_y} \rightarrow \frac{\langle x|\sigma_\infty|y\rangle}{\lambda_y} = \frac{\langle x|\rho_\infty|y\rangle}{\text{tr}(\rho_\infty\Pi)}. \quad (14)$$

All that remains is to show that Gaussian σ_∞ entails a Gaussian ρ_∞ . First we observe (see App. C) that the product of two operators has a characteristic equation

$$\chi_{\sigma_\infty}(\mathbf{q}) \propto \int \chi_{\rho_\infty}(\mathbf{r})\chi_\Pi(\mathbf{q} - \mathbf{r}) \exp(-i\mathbf{r}^T \sigma \mathbf{q} / 2) d\mathbf{r}. \quad (15)$$

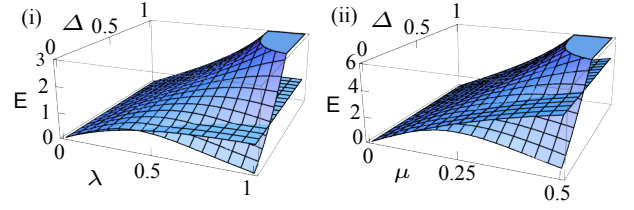

FIG. 2: The degree of entanglement of the initial state ρ in terms of the log-negativity versus the target Gaussian ρ_∞ for (i) bipartite state vectors $|\Psi_\lambda\rangle$ and (ii) tripartite state vectors $|\Phi_\mu\rangle$. In both figures the variable $0 < \Delta < 1$ controls the degree of postselection. The curve varying with Δ is the entanglement of ρ_∞ , and the curve constant in Δ is the initial entanglement of ρ .

For Gaussian χ_Π and χ_{ρ_∞} , the integral is a multi-variate Gaussian integral that evaluates (see App. C) to another Gaussian with the covariance matrix taking the form of a Schur complement [15],

$$\Gamma_\sigma = \Gamma_\Pi - (\Gamma_\Pi + i\Sigma)(\Gamma_{\rho_\infty} + \Gamma_\Pi)^{-1}(\Gamma_\Pi - i\Sigma), \quad (16)$$

Rearranging this formula for Γ_{ρ_∞} gives us the covariance matrix for the convergent state ρ_∞ in terms of Γ_σ and Γ_Π as in the theorem.

Examples. We have introduced a broad class of protocols for which our theorem indicates Gaussification. However, for concreteness it is helpful to keep in mind a simple class of protocols. Consider when each party performs eight-port homodyne measurements that project onto a coherent state. When the k^{th} party obtains outcome α_k projecting onto coherent state vector $|\alpha_k\rangle$, we declare the iteration a success with probability $P = \exp(-|\alpha|^2/2c^2)$. The degree of postselection is quantified by a real variance c . It follows that the filter is indeed proportional to a Gaussian state with covariance matrix $\Gamma_\Pi = \Delta^{-1}\mathbb{1}$, with $\Delta = (1 + c^2)^{3/2}$. This class of protocols is important as it contains GP and EP as limits $\Delta \rightarrow 1$ and $\Delta \rightarrow 0$, respectively.

We now consider the degree of entanglement that is achieved by applying our protocol with eight-port homodyne measurements. First we consider the well-studied bipartite state vector $|\Psi_\lambda\rangle \propto |0, 0\rangle + \lambda|1, 1\rangle$, and present the log-negativity [16] of the convergent Gaussian in Fig. 2. Varying the parameter Δ interpolates between the entanglement achieved by GP and EP, with increased yield compensating for reductions in entanglement. We also analyzed a tripartite entangled state vector $|\Phi_\mu\rangle \propto |0, 0, 0\rangle + \mu(|1, 1, 0\rangle + |1, 0, 1\rangle + |0, 1, 1\rangle)$, having up to two photons in three modes, and for the log-negativity summed over all 3 bipartitions. In fact, in this way, one can straightforwardly engineer multi-partite hybrid distillation protocols for quantum networks, giving rise to primitives in repeater architectures where entanglement is shared across many repeater nodes. These would overcome the known limitations providing a road-block against entirely *Gaussian continuous-variable repeater networks* [17].

Strong convergence. Our previous theorem proves a convergence result identical to that of Ref. [6] and GP. However, it would often be preferable to have convergence of $\langle x|\rho_n|y\rangle$ to $\langle x|\rho_\infty|y\rangle$ in a stronger sense (without the addition factors

of $\text{tr}(\rho_n \Pi)^{-1}$ and $\text{tr}(\rho_\infty \Pi)^{-1}$ and as a convergence in trace-norm). For most physically relevant (see App. D) instances of initial quantum states, we now show that this is indeed the case. We will make use of expectation values of normally ordered operators,

$$\alpha_n^{\mathbf{x}, \mathbf{y}} = \text{tr}[V(\otimes_{k=1}^m \hat{a}_k^{x_k})^\dagger (\otimes_{j=1}^m \hat{a}_j^{y_j}) V^\dagger \sigma_n], \quad (17)$$

where $\mathbf{x}, \mathbf{y} \in \mathbb{N}^m$ and V is the Gaussian unitary such that $V \Pi V^\dagger$ is a thermal state.

Theorem 2 (Strong convergence) *In addition to Theorem 1, if for all $\mathbf{x}, \mathbf{y} \in \mathbb{N}^m$ the expectations values of normally ordered operators satisfy, $|\alpha_0^{\mathbf{x}, \mathbf{y}}| \leq \alpha_\infty^{\mathbf{x}, \mathbf{y}}$ for $\alpha_\infty^{\mathbf{x}, \mathbf{y}} = |\alpha_\infty^{\mathbf{x}, \mathbf{y}}|$. It follows that for all $\epsilon > 0$ there exists an n_ϵ such that for all $n > n_\epsilon$, we have $\|\rho_n - \rho_\infty\| < \epsilon$, where $\|\cdot\|$ is the trace norm.*

The conditions of the theorem are stated technically, but physically prevent overpopulation of higher Fock numbers. E.g., it is easy to check these conditions are met in all the low photon examples analyzed in Fig 2. We begin by first showing $\text{tr}(\Pi \rho_n)$ converges to $\text{tr}(\Pi \rho_\infty)$, which in terms of σ is

$$\text{tr}(\Pi^{-1} \sigma) = \text{tr}(\Pi^{-1} \rho \Pi) / \text{tr}(\rho \Pi) = \text{tr}(\rho \Pi)^{-1}. \quad (18)$$

The inverse filter, Π^{-1} , has an exponential form that can be Taylor expanded and, using the bosonic commutation relation, normally ordered such that $\text{tr}(\Pi^{-1} \sigma_n) = \sum_{\mathbf{x}, \mathbf{y}} q_{\mathbf{x}, \mathbf{y}} \alpha_n^{\mathbf{x}, \mathbf{y}}$, where $q_{\mathbf{x}, \mathbf{y}} \geq 0$. Hence, when the conditions of our theorem hold, we conclude $\text{tr}(\Pi^{-1} \sigma_0) \leq \text{tr}(\Pi^{-1} \sigma_\infty)$, and we proceed by showing this holds for all σ_n . Iteratively we have (details in App. E)

$$\alpha_{n+1}^{\mathbf{x}, \mathbf{y}} = \sum_{\mathbf{u} \leq \mathbf{x}, \mathbf{v} \leq \mathbf{y}} C_{\mathbf{u}, \mathbf{v}}^{\mathbf{x}, \mathbf{y}} \alpha_n^{\mathbf{u}, \mathbf{v}} \alpha_n^{\mathbf{x}-\mathbf{u}, \mathbf{y}-\mathbf{v}}, \quad (19)$$

where $C_{\mathbf{u}, \mathbf{v}}^{\mathbf{x}, \mathbf{y}}$ is a combinatorial quantity that is non-negative and real. Under our assumptions the absolute values obey

$$|\alpha_{n+1}^{\mathbf{x}, \mathbf{y}}| \leq \sum_{\mathbf{u} \leq \mathbf{x}, \mathbf{v} \leq \mathbf{y}} C_{\mathbf{u}, \mathbf{v}}^{\mathbf{x}, \mathbf{y}} \alpha_\infty^{\mathbf{u}, \mathbf{v}} \alpha_\infty^{\mathbf{x}-\mathbf{u}, \mathbf{y}-\mathbf{v}} = \alpha_\infty^{\mathbf{x}, \mathbf{y}}, \quad (20)$$

so initially satisfying our conditions entails satisfaction for all n . Hence, for all n we deduce $\text{tr}(\Pi^{-1} \sigma_n) \leq \text{tr}(\Pi^{-1} \sigma_\infty)$ and equivalently $\text{tr}(\rho_n \Pi) \geq \text{tr}(\rho_\infty \Pi)$. Next we bound $\text{tr}(\rho_n \Pi)$ from above. Consider a finite rank projector P that commutes with Π , then $B = \Pi^{-1} P$ has an absolutely integrable characteristic function. Hence, for arbitrarily small $\delta > 0$ there exists an n_δ such that for $n > n_\delta$

$$\text{tr}(B \sigma_n) - \text{tr}(B \sigma_\infty) = \frac{\text{tr}(P \rho_n)}{\text{tr}(\Pi \rho_n)} - \frac{\text{tr}(P \rho_\infty)}{\text{tr}(\Pi \rho_\infty)} \geq -\delta. \quad (21)$$

Since $\text{tr}(P \rho_n) \leq 1$, and P can be chosen so $\text{tr}(P \rho_\infty) = 1 - \delta'$ is arbitrarily close to unity, we conclude $\text{tr}(\Pi \rho_n)^{-1} - \text{tr}(\Pi \rho_\infty)^{-1} \geq -\epsilon$ where $\epsilon = \delta + \delta' \text{tr}(\rho_\infty \Pi)^{-1}$ is again small. This inequality rearranges to $\text{tr}(\Pi \rho_n) \leq (\text{tr}(\Pi \rho_\infty)^{-1} - \epsilon)^{-1}$, giving an arbitrarily tight bound from above. Combined with our lower bound we conclude that $\text{tr}(\Pi \rho_n)$, under the stated

assumptions, converges to $\text{tr}(\Pi \rho_\infty)$. As such $\langle x | \rho_n | y \rangle$ converges to $\langle x | \rho_\infty | y \rangle$, and as is well known this entails trace norm convergence (See Ref. [12] and App F).

Summary. We have introduced a framework for constructing a range of new protocols for entanglement distillation and manipulation. At the same time, this work provides a unified framework for existing protocols leading to Gaussian states: Notably, the mysterious emergence of Gaussian states in distillation schemes is once again related to an instance of a quantum central limit theorem, albeit for a much more broader class of protocols than previously considered. This framework also allows us to look at Gaussification in experimentally realistic acceptance windows, and to trade-off different figures of merit against each other. Such trade-off control is essential as previous proposals are so heavily postselective that over several iterations the success probability would reduce dramatically, whereas our protocols offer an arbitrarily good chance success. Potential for future research is broad as a unique protocol is defined by every separable Gaussian state. For example, our techniques can be applied to homodyne detection protocols for either multimode entanglement distillation, or single mode squeezing enhancement.

Acknowledgements. We would like to thank the EU (QESSENCE, MINOS, COMPAS), the BMBF (QuOReP), and the EURYI for support, and thank A. Mari, C. Gogolin, V. Nesme, D. E. Browne and M. Ohliger for valuable discussions.

Appendix A: Central limit theorems reviewed

Here we present additional details on the convergence of characteristic functions to a Gaussian function. Our proof follows the classical proofs, such as in Ref. [14], but since $\sigma = \rho \Pi / \text{tr}(\rho \Pi)$ is generally neither positive nor Hermitian there are some notable subtleties and technicalities involved. Ultimately, we aim to prove the following.

Theorem 3 (General quantum central theorem) *If $f_{\sigma, \mathbf{r}_0}(t)$ satisfies $|f_{\sigma, \mathbf{r}_0}(t)| \leq 1$ for all $t \in \mathbb{R}$ then in the limit of large N*

$$f_{\sigma, \mathbf{r}_0}(t/\sqrt{N})^N \rightarrow e^{-\nu t^2/4}, \quad (A1)$$

pointwise in t , with ν as the appropriate second moment. Specifically, pointwise convergence means that for all $t \in \mathbb{R}$ and all $\epsilon > 0$ there exists a N_ϵ such that for all $N > N_\epsilon$ we have

$$|f_{\sigma, \mathbf{r}_0}(t/\sqrt{N})^N - e^{-\nu t^2/4}| \leq \epsilon. \quad (A2)$$

Setting $t = 1$ directly entails pointwise convergence of the characteristic function χ_{σ_n} , and furthermore this is uniform on compact regions, such as a ball in phase space.

Corollary 1 (Convergence in compact regions) *Within any compact region R , χ_{σ_n} converges uniformly to χ_{σ_∞} . That is, for any $\epsilon > 0$ there exists an n_ϵ such that for all $n > n_\epsilon$ and all $\mathbf{r} \in R$, we have $|\chi_{\sigma_n}(\mathbf{r}) - \chi_{\sigma_\infty}(\mathbf{r})| \leq \epsilon$.*

Pointwise convergence is uniform on compact regions whenever the gradient is bounded within R for all n . To prove a gradient bound for all n , we first observe that for $n = 0$ a bounded continuous function always has a gradient bound on compact sets. That is, an η can always be found such that for all $\mathbf{r} \in R$ we have $G_0(\mathbf{r}) = \|\nabla\chi_{\sigma_0}(\mathbf{r})\|_2 < \eta|\mathbf{r}|$, where $\|\cdot\|_2$ denotes the 2-norm. This property is iteratively preserved for all σ_n , since

$$\begin{aligned} G_n(\mathbf{r}) &= \|\nabla\chi_{\sigma_0}(\mathbf{r}/\sqrt{N})^N\|_2, \\ &= N\|\nabla\chi_{\sigma_0}(\mathbf{r}/\sqrt{N})\cdot[\chi_{\sigma_0}(\mathbf{r}/\sqrt{N})^{N-1}]\|_2, \\ &\leq \sqrt{N}G_0(\mathbf{r}/\sqrt{N}) \leq \eta|\mathbf{r}|. \end{aligned}$$

Using the point in the compact region that gives the largest value $|\mathbf{r}|$ giving the desired gradient bound for all $\mathbf{r} \in R$ and all n . This corollary will prove useful in App. B.

We prove several useful lemmas before directly addressing this proof. First we observe,

$$\begin{aligned} f_{\sigma, \mathbf{r}_0}(t) &= \text{tr}[D(\text{tr}_0)\sigma], \\ &= \int_{-\infty}^{\infty} dx e^{ixt} F_{\sigma, \mathbf{r}_0}(x), \end{aligned} \quad (\text{A3})$$

where $F_{\sigma, \mathbf{r}_0}(x)$ is the representation of σ along a line in phase space defined by the unit vector \mathbf{r}_0 (e.g., the position or momentum representation in case of a unit vector pointing along the axis of phase space). This is similar to a probability density for measurement of a particular quadrature; however, because σ is neither positive nor Hermitian, the function F_{σ, \mathbf{r}_0} is not generally positive or real, which is the main cause for caution. Yet it is sufficiently well behaved, with the two following lemmas proving useful.

Lemma 1 (Convergence of absolute integrals) *The absolute integral satisfies $\int_{-\infty}^{\infty} x^2 |F_{\sigma, \mathbf{r}_0}(x)| dx < \infty$.*

Now clearly $(\Pi - i\rho)(\Pi + i\rho) \geq 0$, such that

$$\Pi^2 + \rho^2 \geq i\rho\Pi - i\Pi\rho \quad (\text{A4})$$

and $(\Pi - \rho)(\Pi + \rho) \geq 0$, so that

$$\Pi^2 + \rho^2 \geq \Pi\rho + \rho\Pi. \quad (\text{A5})$$

Similarly, $\Pi^2 + \rho^2 \geq -i\rho\Pi + i\Pi\rho$ and $\Pi^2 + \rho^2 \geq -\Pi\rho - \rho\Pi$. One finds after a few steps that, for any vector $|\psi\rangle$, we have

$$|\langle\psi|\rho\Pi|\psi\rangle| \leq |\langle\psi|(\rho^2 + \Pi^2)|\psi\rangle|/\sqrt{2}. \quad (\text{A6})$$

Hence, using the triangle inequality,

$$|F_{\sigma, \mathbf{r}_0}(x)| \leq \frac{|F_{\Pi^2, \mathbf{r}_0}(x)| + |F_{\rho^2, \mathbf{r}_0}(x)|}{\sqrt{2}|\text{tr}(\rho\Pi)|}. \quad (\text{A7})$$

That is to say, whenever the second moments of Π^2 and ρ^2 are finite, the absolute integral converges to a finite value.

The second lemma we require is as follows.

Lemma 2 (Expansion of functions) *For a given unit vector \mathbf{r}_0 and an operator σ that is unit trace and zero displacement $\mathbf{d}_\sigma = 0$, the above function f_{σ, \mathbf{r}_0} can be expressed as*

$$f_{\sigma, \mathbf{r}_0}(t) = 1 - \frac{1}{4}\nu t^2 K(t) \quad (\text{A8})$$

where $K(t) \rightarrow 1$ as $t \rightarrow 0$.

This lemma asserts that higher order moments drop off sufficiently quickly for the purposes of establishing a central limit theorem. We make use of the following formulation of the exponential function

$$e^{itx} = 1 + itx - \frac{1}{2}t^2 x^2 L(x, t) \quad (\text{A9})$$

where

$$L(x, t) = 2 \int_0^1 (1-u)e^{iutx} du, \quad (\text{A10})$$

satisfying

$$|L(x, t)| \leq 1 \quad (\text{A11})$$

for $x, t \in \mathbb{R}$. Furthermore, for any finite x interval, $e^{iutx} \rightarrow 1$ as $t \rightarrow 0$ uniformly in x . Consequently, we also have $L(x, t) \rightarrow 1$ as $t \rightarrow 0$ uniformly on any finite x -interval. Multiplying Eq. (A9) by F_{σ, \mathbf{r}_0} and integrating w.r.t. x and using the unit trace of σ and vanishing first moments we have

$$f_{\sigma, \mathbf{r}_0}(t) = 1 - \frac{1}{2}t^2 \int_{-\infty}^{\infty} x^2 L(x, t) F_{\sigma, \mathbf{r}_0}(x) dx, \quad (\text{A12})$$

which we can rewrite as

$$f_{\sigma, \mathbf{r}_0}(t) = 1 - \frac{1}{2}t^2 \nu K(t), \quad (\text{A13})$$

where ν is the second moment defined by

$$\nu = 2 \int_{-\infty}^{\infty} x^2 F_{\sigma, \mathbf{r}_0}(x), \quad (\text{A14})$$

and $K(t)$ is the quantity satisfying

$$\nu K(t) = 2 \int_{-\infty}^{\infty} x^2 L(x, t) F_{\sigma, \mathbf{r}_0}(x). \quad (\text{A15})$$

If we subtract Eq. (A14) from the above, we have

$$\nu(K(t) - 1) = 2 \int_{-\infty}^{\infty} x^2 (L(x, t) - 1) F_{\sigma, \mathbf{r}_0}(x). \quad (\text{A16})$$

The absolute value satisfies

$$\nu|K(t) - 1| \leq 2 \int_{-\infty}^{\infty} x^2 |(L(x, t) - 1) F_{\sigma, \mathbf{r}_0}(x)|. \quad (\text{A17})$$

Noting that $|L(x, t) - 1| \leq 2$ since $|L(x, t)| \leq 1$, and dividing the integral into two parts over some finite interval R and the complement R^\perp we deduce that

$$\begin{aligned} \nu|K(t) - 1| &\leq 2 \int_R x^2 |(L(x, t) - 1) F_{\sigma, \mathbf{r}_0}(x)| \\ &\quad + 4 \int_{R^\perp} x^2 |F_{\sigma, \mathbf{r}_0}(x)|. \end{aligned} \quad (\text{A18})$$

We now make use of Lem. (1) which tells us that the second integral always converges to a finite value. Therefore, for any $\epsilon > 0$ the region R can be choose sufficiently large that the second integral is bounded such that

$$\nu|K(t) - 1| \leq 2 \int_R x^2 |(L(x, t) - 1)F_{\sigma, \mathbf{r}_0}(x)| + \epsilon \quad (\text{A19})$$

Recall that for finite x interval, such as R , $(L(x, t) - 1)$ uniformly goes to zero with vanishing t . Hence, for any $\epsilon > 0$ and $x \in R$ there exists a t_ϵ such that for all $|t| < t_\epsilon$ we have

$$\nu|K(t) - 1| \leq 2\epsilon. \quad (\text{A20})$$

We conclude that $K(t)$ converges to 1 with vanishing t , proving our lemma.

We now employ the above lemmas to demonstrate pointwise convergence. We wish to bound the quantity

$$\delta(t, N) = |f_{\sigma, \mathbf{r}_0}(t/\sqrt{N})^N - e^{-\nu t^2/4}|, \quad (\text{A21})$$

which can be expanded as

$$\delta(t, N) = |(1 - \frac{\nu t^2}{4N} K(t/\sqrt{N}))^N - e^{-\nu t^2/4}|. \quad (\text{A22})$$

In the limit of large N we have that

$$\delta(t, N) = \left| \left(1 - \frac{\nu t^2}{4N} K(t/\sqrt{N})\right)^N - \left(1 - \frac{\nu t^2}{4N}\right)^N \right|. \quad (\text{A23})$$

For any a and b satisfying $|a|, |b| \leq 1$ it is well known that

$$|a^N - b^N| \leq N|a - b|. \quad (\text{A24})$$

Applying this inequality to our problem gives

$$\begin{aligned} \delta(t, N) &\leq N \left| \left(1 - \frac{\nu t^2}{4N} K(t/\sqrt{N})\right) - \left(1 - \frac{\nu t^2}{4N}\right) \right|, \\ &\leq |\nu t^2 (K(t/\sqrt{N}) - 1)|/4. \end{aligned} \quad (\text{A25})$$

For fixed t , the argument of $K(t/\sqrt{N})$ vanishes as N increases, entailing pointwise convergence. Consider a point t , for any $\epsilon > 0$ we can always find a u_ϵ such that $|K(u) - 1| \leq 4\epsilon/(\nu t^2)$ for all $|u| \leq u_\epsilon$. The variable u_ϵ defines a $N_\epsilon = t_\epsilon^2 u_\epsilon^2$, such that $|u| = |t/\sqrt{N}| \leq u_\epsilon$ whenever $N > N_\epsilon$ and so

$$\delta(t, N > N_\epsilon) \leq \epsilon. \quad (\text{A26})$$

Hence we have shown Thm. 3. Furthermore, this convergence is uniform on finite intervals of t .

Appendix B: Convergence of expectation values

In the letter we state that convergence of χ_{σ_n} to a Gaussian function with covariance matrix Γ_{σ_∞} entails convergence for

the expectation value of operators, B , with absolutely integrable characteristic functions. Here we prove the relevant lemma, and also show that its conditions are meet for operators of the form $B = |x\rangle\langle y|$ where $|x\rangle$ and $|y\rangle$ are, up to a Gaussian unitary, multimode Fock states. Note that, when σ_n are positive Hermitian operators, stronger conclusions can be reached by a similar means as shown in Ref. [11].

Lemma 3 (Convergence of expectation values) *Consider a sequence of trace class m -mode operators σ_n and a limiting operator σ_∞ , such that (i) $|\chi_{\sigma_n, \infty}(\mathbf{r})| \leq 1$ for all \mathbf{r} and (ii) For any compact region, R , χ_{σ_n} converges uniformly to χ_{σ_∞} . Consider also a trace class operator B satisfying $\int |\chi_B(\mathbf{r})| d\mathbf{r} < \infty$ and any $\epsilon > 0$. There exists an n_ϵ such that for all $n_\epsilon < n$*

$$|\text{tr}(B\sigma_n) - \text{tr}(B\sigma_\infty)| \leq \epsilon. \quad (\text{B1})$$

For the sequence of characteristic functions considered in the letter, property (i) is a prerequisite and property (ii) was shown in Cor. (1). We state these properties again here for clarity. First we note that for any two m -mode trace class operators, B and A , the characteristic functions, χ_B and χ_A , satisfy

$$\int d\mathbf{r} \chi_B(\mathbf{r}) \chi_A(\mathbf{r}) = (2\pi)^m \text{tr}(BA). \quad (\text{B2})$$

This entails that

$$D_n = (2\pi)^m |\text{tr}(B\sigma_n) - \text{tr}(B\sigma_\infty)| \quad (\text{B3})$$

$$= \left| \int \chi_B(\mathbf{r}) [\chi_{\sigma_n}(\mathbf{r}) - \chi_{\sigma_\infty}(\mathbf{r})] d\mathbf{r} \right|. \quad (\text{B4})$$

Next we observe that for any χ_B satisfying $\int |\chi_B(\mathbf{r})| d\mathbf{r} < \infty$, and for any $\epsilon > 0$ we can find a function h with compact support such that

$$\int |\chi_B(\mathbf{r}) - h(\mathbf{r})| d\mathbf{r} \leq \epsilon. \quad (\text{B5})$$

That is, the set of functions with compact support are dense in the set of absolutely integrable functions. Defining $\eta(\mathbf{r}) = \chi_B(\mathbf{r}) - h(\mathbf{r})$ and $\Delta_n(\mathbf{r}) = \chi_{\sigma_n}(\mathbf{r}) - \chi_{\sigma_\infty}(\mathbf{r})$, we have

$$D_n = \left| \int [\eta(\mathbf{r}) - h(\mathbf{r})] \Delta_n(\mathbf{r}) d\mathbf{r} \right|, \quad (\text{B6})$$

$$\leq \left| \int \eta(\mathbf{r}) \Delta_n(\mathbf{r}) d\mathbf{r} \right| + \left| \int h(\mathbf{r}) \Delta_n(\mathbf{r}) d\mathbf{r} \right|,$$

$$\leq \sup(|\Delta_n(\mathbf{r})|) \int |\eta(\mathbf{r})| d\mathbf{r} + \left| \int h(\mathbf{r}) \Delta_n d\mathbf{r} \right|,$$

$$\leq 2\epsilon + \left| \int h(\mathbf{r}) \Delta_n d\mathbf{r} \right|.$$

The third line uses a Hölder's inequality. The final line uses Eq. (B5) and $|\Delta_n(\mathbf{r})| \leq 2$. For sufficiently large n , the second term can also be made arbitrarily small because h has compact support and Δ_n vanishes uniformly on any compact set, as required by property (ii). This completes the proof of the lemma.

Furthermore, any operator $B = |x\rangle\langle y|$ will satisfy the conditions of the lemma when $|x\rangle$ and $|y\rangle$ are eigenvectors of a Gaussian density operator. That is, there exists a Gaussian unitary such that $U|x\rangle$ and $U|y\rangle$ are Fock states. Clearly B is trace class, and so we only need show absolute convergence of χ_B . For a 1-mode element in the Fock basis $|n\rangle\langle m|$ the characteristic function will be a product of a real polynomial in \mathbf{r} of finite degree and a decaying Gaussian in $|\mathbf{r}|$. Such functions are easily seen to absolutely converge, and so too shall a product of m such functions. A Gaussian displacement only adds a phase factor to the characteristic function, and non-displacing Gaussian unitaries are equivalent to a unitary change of variables in the integral. Hence, Gaussian unitaries will not alter the value of the absolute integral. Indeed, most trace class operators are easily seen to have absolutely integrable characteristic functions. However, we do not currently know if this is generally true.

Appendix C: Gaussian integrals and the Schur complement

The product of two operators, e.g., $\rho\Pi$ has a characteristic function that equals an integral involving the characteristic functions for ρ and Π as expressed by Eq. (15) of the letter. Furthermore, for Gaussian states this integral is solved by taking the Schur complement of an appropriate matrix (see Eq. (16) of the letter). These techniques are standard, but for the purpose of completeness we shall review them here.

As a side remark, note that an alternative strategy towards formulating generalized quantum central limit theorems would have been to consider objects of the form $\Pi^{1/2}\rho\Pi^{1/2}/\text{tr}(\Pi\rho)$ instead of $\Pi\rho/\text{tr}(\Pi\rho)$. While this constitutes an alternative in principle, the resulting Schur complement expressions become much more involved, motivating the path taken above.

We begin by noting that for any trace class operator A , the formula for the characteristic function can be inverted such that

$$A \propto \int d\mathbf{r} \chi_A(\mathbf{r}) D(-\mathbf{r}). \quad (\text{C1})$$

Hence, the product of two operators satisfies

$$AB \propto \int \int d\mathbf{r} d\mathbf{r}' \chi_A(\mathbf{r}) \chi_B(\mathbf{r}') D(-\mathbf{r}) D(-\mathbf{r}'). \quad (\text{C2})$$

The Campbell-Baker-Hausdorff formula entails that

$$D(-\mathbf{r}) D(-\mathbf{r}') = D(-(\mathbf{r} + \mathbf{r}')) \exp(-i\mathbf{r}^T \Sigma \mathbf{r}'/2), \quad (\text{C3})$$

and so

$$AB \propto \int d\mathbf{r} d\mathbf{r}' \chi_A(\mathbf{r}) \chi_B(\mathbf{r}') D(-(\mathbf{r} + \mathbf{r}')) \exp(-i\mathbf{r}^T \Sigma \mathbf{r}'/2). \quad (\text{C4})$$

Changing variables to $\mathbf{q} = \mathbf{r} + \mathbf{r}'$ and $\mathbf{r} = \mathbf{r}$ yields,

$$AB \propto \int d\mathbf{r} d\mathbf{q} \chi_A(\mathbf{r}) \chi_B(\mathbf{q} - \mathbf{r}) D(-\mathbf{q}) \exp(-\frac{i}{2}\mathbf{r}^T \Sigma (\mathbf{q} - \mathbf{r})). \quad (\text{C5})$$

Noting that $\mathbf{r}^T \Sigma \mathbf{r} = 0$ for all \mathbf{r} eliminates part of the exponent. Next we observe that this has the form of Eq. (C1) and so we can deduce that the characteristic function is

$$\chi_{AB}(\mathbf{q}) \propto \int d\mathbf{r} \chi_A(\mathbf{r}) \chi_B(\mathbf{q} - \mathbf{r}) \exp(-\frac{i}{2}\mathbf{r}^T \Sigma \mathbf{q}). \quad (\text{C6})$$

Setting $A = \rho_\infty$ and $B = \Pi$ provides Eq. 15 of the letter.

Until now we have not used any properties of A or B , but herein assume they are Gaussian with covariance matrices Γ_A and Γ_B . Hence

$$\begin{aligned} \chi_{AB}(\mathbf{q}) &\propto \int d\mathbf{r} \exp\left(-\frac{\mathbf{r}^T \Gamma_A \mathbf{r}}{4}\right) \\ &\times \exp\left(-\frac{(\mathbf{q} - \mathbf{r})^T \Gamma_B (\mathbf{q} - \mathbf{r})}{4} - \frac{i}{2}\mathbf{r}^T \Sigma \mathbf{q}\right). \end{aligned} \quad (\text{C7})$$

This can be expressed more compactly using a single matrix

$$\chi_{AB}(\mathbf{q}) \propto \int \exp(-(\mathbf{q}, \mathbf{r})^T M (\mathbf{q}, \mathbf{r})/4) d\mathbf{r}, \quad (\text{C8})$$

where M is the Block matrix

$$M = \begin{pmatrix} \Gamma_B & -\Gamma_B \\ 2i\Sigma - \Gamma_B & \Gamma_A + \Gamma_B \end{pmatrix}. \quad (\text{C9})$$

Observing that $\mathbf{r} \Sigma \mathbf{q} = -\mathbf{q} \Sigma \mathbf{r}$ allows explicit symmetrization,

$$M = \begin{pmatrix} \Gamma_B & -\Gamma_B - i\Sigma \\ i\Sigma - \Gamma_B & \Gamma_A + \Gamma_B \end{pmatrix}, \quad (\text{C10})$$

such that now $M = M^T$. The Schur complement arises by decomposing the matrix as $M = N D N^T$, with

$$D = \begin{pmatrix} \text{Sc}(M) & 0 \\ 0 & \Gamma_A + \Gamma_B \end{pmatrix}, \quad (\text{C11})$$

$$N = \begin{pmatrix} \mathbb{1} & -(\Gamma_A + i\Sigma)(\Gamma_A + \Gamma_B)^{-1} \\ 0 & \mathbb{1} \end{pmatrix}, \quad (\text{C12})$$

where $\text{Sc}(M)$ denotes the Schur complement of M ,

$$\text{Sc}(M) = \Gamma_B - (\Gamma_B + i\Sigma)(\Gamma_A + \Gamma_B)^{-1}(\Gamma_B - i\Sigma). \quad (\text{C13})$$

This decomposition requires only that M is symmetric and that $\Gamma_A + \Gamma_B$ is invertible. Returning to our Gaussian integral, a change of variables $(\mathbf{q}, \mathbf{r}) N^T \mapsto (\mathbf{q}, \mathbf{r})$ gives

$$\chi_{AB}(\mathbf{q}) \propto \int \exp(-(\mathbf{q}, \mathbf{r})^T D (\mathbf{q}, \mathbf{r})/4) d\mathbf{r}, \quad (\text{C14})$$

and so the \mathbf{q} and \mathbf{r} variables decouple, and the integral evaluates to some number and

$$\chi_{AB}(\mathbf{q}) \propto \exp(-\mathbf{q}^T \text{Sc}(M) \mathbf{q}/4) d\mathbf{r}. \quad (\text{C15})$$

Hence, we have that $\Gamma_{AB} = \text{Sc}(M)$. By substituting in $\Gamma_A = \Gamma_{\rho_\infty}$ and $\Gamma_B = \Gamma_\Pi$ we obtain Eq. (16) of the letter.

Appendix D: Notions of weak convergence

Here we briefly discuss technicalities related to notions of weak convergence versus convergence in trace-norm. Interestingly, these different notions can have a physical implication. While in many experimentally relevant examples the conditions of Thm. (2) of the letter are satisfied, one can concoct exotic instances for which strong convergence fails. For example, if we consider the 2-mode state vector

$$|\psi_0\rangle \propto |0,0\rangle + 0.1|1,1\rangle + 6|2,2\rangle \quad (\text{D1})$$

and apply the GP protocol, then Thm. (2) of the letter holds for a target Gaussian

$$|\psi_\infty\rangle \propto \sum_n (1/10)^n |n,n\rangle. \quad (\text{D2})$$

However, once correctly normalized, straightforward numerics show the state diverges with fidelity $\langle \psi_n | \psi_\infty \rangle$ vanishing with n . This highlights the importance of proving more robust convergence results. Stronger convergence has only been established for EP, where trivially $\text{tr}(\rho_n \Pi) = \text{tr}(\rho_\infty \Pi)$ since $\Pi = \mathbb{1}$. On a theoretical level, it is compelling to ask what the necessary and sufficient conditions are for strong convergence of GG.

Appendix E: Iterative formula

Here we go through the details of the iterative formula of Eq. (19). For brevity, we assume Π is diagonal in the Fock basis, and so $V = \mathbb{1}$, though the more general case can be proven by the same method but more cluttered notation. For the $(n+1)$ th round we have that the state satisfies

$$\begin{aligned} \sigma_{n+1}^{\mathbf{x},\mathbf{y}} &= \frac{\text{tr}^2[U(\rho_n \otimes \rho_n)U^\dagger(\Pi \otimes \Pi)]}{\text{tr}[U(\rho_n \otimes \rho_n)U^\dagger(\Pi \otimes \Pi)]} \\ &= \frac{\text{tr}^2[U(\rho_n \otimes \rho_n)U^\dagger(\Pi \otimes \Pi)]}{\text{tr}[\rho_n \Pi]^2} \end{aligned}$$

and so the expectation values satisfy

$$\begin{aligned} \alpha_{n+1}^{\mathbf{x},\mathbf{y}} &= \frac{\text{tr}[(\otimes_k \hat{a}_{k,1}^{x_k})^\dagger (\otimes_j \hat{a}_{j,1}^{y_j}) U(\rho_n \otimes \rho_n) U^\dagger(\Pi \otimes \Pi)]}{\text{tr}[\rho_n \Pi]^2} \\ &= \text{tr}[U^\dagger (\otimes_k \hat{a}_{k,1}^{x_k})^\dagger (\otimes_j \hat{a}_{j,1}^{y_j}) U(\sigma_n \otimes \sigma_n)]. \end{aligned}$$

Next we must find the effect of conjugating the unitary through the annihilation/creation operators.

$$\begin{aligned} &U^\dagger (\otimes_k \hat{a}_{k,1}^{x_k})^\dagger (\otimes_j \hat{a}_{j,1}^{y_j}) U \\ &= \left(\otimes_{k=1}^m \left(\frac{\hat{a}_{k,1} + \hat{a}_{k,2}}{\sqrt{2}} \right)^{x_k} \right)^\dagger \left(\otimes_{j=1}^m \left(\frac{\hat{a}_{j,1} + \hat{a}_{j,2}}{\sqrt{2}} \right)^{y_j} \right) \\ &= \sum C_{\mathbf{u},\mathbf{v}}^{\mathbf{x},\mathbf{y}} (\otimes_k \hat{a}_{k,1}^{u_k}) (\otimes_k \hat{a}_{k,2}^{x_k - u_k}) (\otimes_j \hat{a}_{j,2}^{v_j}) (\otimes_j \hat{a}_{j,2}^{y_j - v_j}) \end{aligned}$$

where in the last line we have simply noted that all the binomial factors and contributions of $1/\sqrt{2}$ are non-negative and real numbers, and so sum to a non-negative number

$C_{\mathbf{u},\mathbf{v}}^{\mathbf{x},\mathbf{y}}$. The exact value of these numbers are unimportant to us here. We substitute this expression for the conjugated annihilation/creation operators into that for $\alpha_{n+1}^{\mathbf{x},\mathbf{y}}$. Evaluating the trace, we replace the operators on the right hand side with the variables of the form $\alpha_n^{\mathbf{u},\mathbf{v}}$ and arrive at the desired formula.

Appendix F: Trace norm convergence

Here we give our own version of the well known proof of trace norm convergence of ρ_n to ρ_∞ from point-wise convergence of the density matrix elements. First we note that for any $\epsilon > 0$ there exists a projector P of finite rank that commutes with Π , such that $\text{tr}(P\rho_\infty) > 1 - \epsilon$. It is useful to denote $P = \sum_{x \in X} |x\rangle\langle x|$ where X is a finite set of eigenvectors of Π . Furthermore, we can find an n_ϵ such that for all $n > n_\epsilon$ we also have

$$\text{tr}(P\rho_\infty) - \text{tr}(P\rho_n) < \epsilon. \quad (\text{F1})$$

Combining this with $\text{tr}(P\rho_\infty) > 1 - \epsilon$, gives

$$\text{tr}(P\rho_n) > 1 - 2\epsilon. \quad (\text{F2})$$

Next we observe that the trace norm can be bounded as follows,

$$\begin{aligned} &\|\rho_n - \rho_\infty\|_1 \\ &= \|(P(\rho_n - \rho_\infty)P + (\rho_n - P\rho_n P) - (\rho_\infty - P\rho_\infty P))\|_1 \\ &\leq \|P(\rho_n - \rho_\infty)P\|_1 + \|\rho_n - P\rho_n P\|_1 \\ &\quad + \|\rho_\infty - P\rho_\infty P\|_1 \end{aligned} \quad (\text{F3})$$

Let us consider the first term, which satisfies

$$\|P(\rho_n - \rho_\infty)P\|_1 \leq \sum_{x,y \in X} |\langle y | \rho_n | x \rangle - \langle y | \rho_\infty | x \rangle|. \quad (\text{F4})$$

By our previously established results, for every pair $|x\rangle, |y\rangle \in X$, there exists an $n_{\epsilon,x,y}$ such that for all $n > n_{\epsilon,x,y}$, we have

$$|\langle y | \rho_n | x \rangle - \langle y | \rho_\infty | x \rangle| < \epsilon/|X|^2 \quad (\text{F5})$$

Hence, for all $n > n_*$ where $n_* = \max\{n_{\epsilon,x,y}, n_\epsilon\}$ we have

$$\|P(\rho_n - \rho_\infty)P\|_1 < \epsilon. \quad (\text{F6})$$

We next consider the third term of Eq. (F3), noting that

$$\begin{aligned} \|\rho_\infty - P\rho_\infty P\|_1 &\leq 2\|P\rho_\infty(1-P)\|_1, \\ &\quad + \|(1-P)\rho_\infty(1-P)\|_1. \end{aligned} \quad (\text{F7})$$

The later term is simply $\|(1-P)\rho_\infty(1-P)\|_1 = \text{tr}((1-P)\rho_\infty) < \epsilon$. Since ρ_∞ is Hermitian and positive we deduce

$$\|P\rho_\infty(1-P)\|_1 \leq \sqrt{\|P\rho_\infty P\|_1 \|(1-P)\rho_\infty(1-P)\|_1},$$

which easily shown to be an equality when ρ_∞ is pure, with the inequality following for mixed states. Noting $\|P\rho_\infty P\|_1 \leq 1$ and again $\|(1-P)\rho_\infty(1-P)\|_1 < \epsilon$ gives

$$\|P\rho_\infty(1-P)\|_1 < \sqrt{\epsilon},$$

and so

$$\|\rho_\infty - P\rho_\infty P\|_1 < 2\sqrt{\epsilon} + \epsilon. \quad (\text{F8})$$

By a similar argument we can also show that for all $n > n_\epsilon$,

$$\|\rho_n - P\rho_n P\|_1 < \sqrt{2\epsilon} + 2\epsilon. \quad (\text{F9})$$

Putting these pieces together entails that for all $n > n^*$,

$$\|\rho_n - \rho_\infty\|_1 < 4\epsilon + (2 + \sqrt{2})\sqrt{\epsilon}. \quad (\text{F10})$$

Hence, for any desired trace norm accuracy, and hence also fidelity, there always exists a number of iterations, n^* , above which the protocol achieves this accuracy.

-
- [1] C. H. Bennett, G. Brassard, S. Popescu, B. Schumacher, J. A. Smolin, and W. K. Wootters, *Phys. Rev. Lett.* **76**, 722 (1996).
- [2] W. Dür, H. J. Briegel, J. I. Cirac, and P. Zoller, *Phys. Rev. A* **59**, 169 (1999); L. Childress, J. M. Taylor, A. S. Sørensen, and M. D. Lukin, *Phys. Rev. A* **72**, 052330 (2005).
- [3] P. van Loock et al., *Phys. Rev. Lett.* **96**, 240501 (2006).
- [4] N. Sangouard, C. Simon, H. de Riedmatten, N. Gisin, *Rev. Mod. Phys.* **83**, 33 (2011); N. Sangouard, C. Simon, N. Gisin, J. Laurat, R. Tualle-Brouri, and P. Grangier, *J. Opt. Soc. Am. B* **27**, A137 (2010); R. Kaltenbaek, R. Prevedel, M. Aspelmeyer, and A. Zeilinger, *Phys. Rev. A* **79**, 040302(R) (2009).
- [5] J. Eisert, S. Scheel, and M. B. Plenio, *Phys. Rev. Lett.* **89**, 137903 (2002); J. Fiurasek, *ibid.* **89**, 137904 (2002); G. Giedke and J. I. Cirac, *Phys. Rev. A* **66**, 032316 (2002).
- [6] J. Eisert, D. E. Browne, S. Scheel, and M. B. Plenio, *Ann. Phys.* **311**, 431 (2004); D. E. Browne, J. Eisert, S. Scheel, and M. B. Plenio, *Phys. Rev. A* **67**, 062320 (2003); J. Eisert, M. B. Plenio, D. E. Browne, S. Scheel, and A. Feito, *Opt. Spec.* **103**, 173 (2007).
- [7] B. Hage, A. Sambrowski, J. DiGuglielmo, A. Franzen, J. Fiurasek, and R. Schnabel, *Nature Phys.* **4**, 915 (2008); R. Dong et al., *Nature Phys.* **4**, 919 (2008); H. Takahashi et al., *Nature Phot.* **4**, 178 (2010); B. Hage, A. Sambrowski, J. DiGuglielmo, J. Fiurasek, and R. Schnabel, arXiv:1007.1508; J. Wenger, R. Tualle-Brouri, and P. Grangier, *Phys. Rev. Lett.* **92**, 153601 (2004).
- [8] J. Fiurasek, *Phys. Rev. A* **82**, 042331 (2010).
- [9] U. Leonhardt, *Measuring the quantum state of light* (Cambridge University Press, 1997).
- [10] M.M. Wolf, G. Giedke, and J. I. Cirac, *Phys. Rev. Lett.* **96**, 080502 (2006).
- [11] C. D. Cushen and R. L. Hudson, *J. Appl. Prob.* **8**, 454 (1971).
- [12] E. B. Davies, *Commun. Math. Phys.* **15**, 277 (1969); E. B. Davies, *Commun. Math. Phys.* **27**, 309 (1972).
- [13] M. Cramer and J. Eisert, *New J. Phys.* **12**, 055020 (2010).
- [14] P. A. Moran, *An introduction to probability theory* (Oxford University Press, 2002).
- [15] R. Horn and C. Johnson, *Matrix analysis* (Cambridge University Press, 1985).
- [16] J. Eisert, PhD thesis (Potsdam, February 2001); G. Vidal and R. F. Werner, *Phys. Rev. A* **65**, 032314 (2002); M. B. Plenio, *Phys. Rev. Lett.* **95**, 090503 (2005).
- [17] M. Ohliger, K. Kieling, and J. Eisert, *Phys. Rev. A* **82**, 042336 (2010).